



- (51) International Patent Classification:
E01C 21/00 (2006.01)
- (21) International Application Number:
PCT/RU2012/001031
- (22) International Filing Date:
7 December 2012 (07.12.2012)
- (25) Filing Language: English
- (26) Publication Language: English
- (30) Priority Data:
2012141514 28 September 2012 (28.09.2012) RU
- (71) Applicant: **OBSHESTVO S OGRANICHENNOY OTVETSTVENNOSTYU "INFRASTRUCTURNYE TEHNOLOGIYI"** [RU/RU]; ul. Pokrovka 47A, Moscow, 105062 (RU).
- (72) Inventors: **MURATOV, Gely Rostislavovich**; ul. Nikolaya Nikonova, 10, kv. 29, g. Ekaterinburg, Sverdlovskaya obl., 620027 (RU). **SOLOV'EV, Victor Alekseevich**; ul. Altayskaya, 49, kv. 83, Nizhnyi Tagyl, 622018 (RU). **DUDIN, Victor Ivanovich**; ul. Avtomagistralnaya, 5, kv. 27, Ekaterinburg, 620141 (RU). **MANDRYGIN, Artem Victorovich**; ul. Lenina, 52, korp. 3a, kv. 371, Ekaterinburg, 620075 (RU). **GOLOLOBOV, Yuri Vladimirovich**; Olympyskiy pr-t., 26, kv.62, Moscow, 127292 (RU). **MURATOV, Denis Gelievich**; ul. Beregovaya, 8, korp. 1, kv. 73, Moscow, 125367 (RU). **MELIORANSKYI, Aleksei Valentinovich**; ul. Mitinskaya, 53, kv. 40, Moscow, 125310 (RU).
- (74) Agent: **PYLNEV, Yuri Aleksandrovich**; Baker & McKenzie - CIS, Limited, Dolgorukovskaya St., 7, Sadovaya Plaza, 11th Floor, Moscow, 127006 (RU).
- (81) Designated States (*unless otherwise indicated, for every kind of national protection available*): AE, AG, AL, AM, AO, AT, AU, AZ, BA, BB, BG, BH, BN, BR, BW, BY, BZ, CA, CH, CL, CN, CO, CR, CU, CZ, DE, DK, DM, DO, DZ, EC, EE, EG, ES, FI, GB, GD, GE, GH, GM, GT, HN, HR, HU, ID, IL, IN, IS, JP, KE, KG, KM, KN, KP, KR, KZ, LA, LC, LK, LR, LS, LT, LU, LY, MA, MD, ME, MG, MK, MN, MW, MX, MY, MZ, NA, NG, NI, NO, NZ, OM, PA, PE, PG, PH, PL, PT, QA, RO, RS, RU, RW, SC, SD, SE, SG, SK, SL, SM, ST, SV, SY, TH, TJ, TM, TN, TR, TT, TZ, UA, UG, US, UZ, VC, VN, ZA, ZM, ZW.
- (84) Designated States (*unless otherwise indicated, for every kind of regional protection available*): ARIPO (BW, GH, GM, KE, LR, LS, MW, MZ, NA, RW, SD, SL, SZ, TZ, UG, ZM, ZW), Eurasian (AM, AZ, BY, KG, KZ, RU, TJ, TM), European (AL, AT, BE, BG, CH, CY, CZ, DE, DK, EE, ES, FI, FR, GB, GR, HR, HU, IE, IS, IT, LT, LU, LV, MC, MK, MT, NL, NO, PL, PT, RO, RS, SE, SI, SK, SM, TR), OAPI (BF, BJ, CF, CG, CI, CM, GA, GN, GQ, GW, ML, MR, NE, SN, TD, TG).
- Published:
— *with international search report (Art. 21(3))*



(54) Title: GEOGRID LAYING MACHINE WITH EQUIPMENT FOR GEOGRID STORAGE AND EXPANSION DURING THE LAYING THEREOF

(57) Abstract: The invention relates to construction using geogrids. The application proposes a refined geogrid laying machine, comprising equipment for storing and expanding the geogrid, including a spool rotating on a frame and designed to wind, store and unwind a length of geogrid consisting of separate geogrid modules of predetermined sizes connected in series, the said spool being connected with an actuator enabling control of uniform winding and/or unwinding the length of the geogrid along the spool axis, means for advancing the length of geogrid along a guideway from the spool, at least two cross members that provide for expanding the geogrid and can be forced apart to form a predetermined angle between them, the said cross members being connected with engaging means to hold the geogrid edges in the process of its expanding between the said cross members.

connected thereto is conducted practically immediately after their formation as a result of a stretching operation that allows using provisional anchorage pillars keeping the geocell in a stretched state only at the initial part of geomaterial installation, until their filling, with their subsequent removal. Further stretching does not require using anchorage pillars because
5 geotextile and geocell will be held by a layer of filled material.

The use of geotextile is optional and defined by tasks solved during construction. If necessary (for example, in case of the repair of a railroad without the removal of sleeper frames), the laying machine is equipped with a mechanism for lifting the sleeper frames and a device for feeding geomaterials into the area under sleepers, a device for stretching
10 geomaterials, filling, leveling and compacting bulk material, the said devices being in operating state in the area under sleepers.

The operating tools of the stretching device can be in the form of plates, disks, boxes and so on structurally connected to sprockets or any other constructive elements which interact with geocell walls during its movement providing its reliable fixing without any
15 breakdown.

A mechanical method for laying the geocell is implemented as follows.

A laying machine platform is installed on a road segment (site) under repair where all technological operations on site preparation preceding the laying of geomaterials have been completed. The Geocell is pulled-out from the spool (drum) to the required length. This
20 pulling-out is implemented manually or by means of manually- or electrically operated winches or any other similar mechanisms. Then the geocell is turned in a transverse plane by the required angle to place the geocell on the edge for stretching. A stretching device is arranged over the geocell, its boxes are inserted by their edges into pockets of a geocell section and forced apart by an angle appropriate for stretching the geocell to a predetermined
25 width.

After several rows of cells of the stretched geocell are filled it is firmly fixed on the road bed by a weight of filled material. This process is continued until all geomaterials are consumed, whereupon the spool and roll are replaced or, according to the laying machine design, replenished.

The disadvantages of the closest analogue are the insufficient mechanization of the
30 geocell's winding and unwinding from the spool and also the geocell expanding process, the complexity of controlling the uniformity of winding, unwinding and expanding, and hence the insufficient effectiveness of works on geocell laying.

The main objective of the proposed technical solution is the elimination of the cited

disadvantages owing to the mechanization of winding, unwinding and expanding the geocell and also improvement of the laying machine.

To solve this problem the present invention provides a geocell laying machine comprising equipment for storing and expanding the geocell, the said equipment including a
5 spool rotating on a frame and designed to wind, store and unwind a length of geocell consisting of separate geocell modules of predetermined sizes connected in series, the said spool being connected with an actuator providing control of uniform winding and/or unwinding the length of the geocell along the spool axis, means for advancing the length of the geocell along an axis from the spool, at least two cross members that enable the expanding
10 of the geocell and can be forced apart to form a predetermined angle between them, the said cross members being connected with engaging means to hold the geocell edges in the process of its expanding between the said cross members.

The actuator further allows turning the length of the geocell to the flat position to provide for its winding to the spool and also turning the length of the geocell to the sideways
15 position during its unwinding from the spool to provide for advancing the length of the geocell along the guideway to the cross members.

The means for advancing the length of geocell comprise guiding and/or pulling-out rollers and a power drive whose rate of rotation is consistent with the speed of the laying machine to provide for a uniform advancing of the length of the geocell. The means for
20 advancing the length of the geocell can also comprise restraints to prevent the ejection of the length of the geocell from the guideway in the course of operation of the laying machine.

Also equipment for storing the geocell is provided in the invention comprising a spool rotating on a frame and designed to wind, store and unwind a length of geocell consisting of separate geocell modules of predetermined sizes connected in series, the said spool being
25 connected with an actuator providing control of uniform winding and/or unwinding the length of the geocell along the spool axis.

Preferably, movements of the spool and actuator are synchronized by means of an automatic control system. Specifically, this concerns the synchronization of motor speeds in accordance with placement parameters.

Also equipment for expanding the geocell during its laying by means of a laying
30 machine is provided in the invention, the said equipment comprising means for advancing a length of geocell consisting of separate geocell modules of predetermined sizes connected in series along a guideway, at least two cross members that provide for expanding the geocell and can be forced apart to form a predetermined angle between them, the cross members

being connected with engaging means to hold the geocell's edges in the process of its expanding between the cross members.

Preferably, the said equipment comprises guiding and/or pulling-out rollers and a power drive whose rate of rotation is consistent with the speed of the laying machine to provide for the uniform advancing of the length of the geocell and also restraints to prevent the ejection of the length of the geocell from the guideway.

The three-dimensional geocell is manufactured in the form of sections from polymer bands by connecting them using seams (for example, lateral linear weld seams arranged chequerwise), which are compact modules while storing and can be stretched in use into a three-dimensional cellular structure. Examples of geocell are known from Russian patents №№ 40751, 98763 for utility models.

The said geocell sections (modules) have generally parallelepiped form with the following sizes: length of about 6 m, height of up to 0.2 m, and width (thickness) of about 0.12 m. These sizes can be changed but because the modules are of sufficient weight (about 10 kg per meter of a module), an increase in their length has essential limitations concerning storage, transportation and laying. Generally geocell modules are stored in stacks and are expanded in use and attached to each other by metal staples using a mechanical (electromechanical) stapler according to a technological process.

For storing, transporting and carrying out works on use of a geocell it is proposed in the present invention to use not the above-mentioned separate modules but their sets combined into one length of a geocell having a predetermined size, which can be wound to a spool to feed the geocell to a mechanism for its stretching (expanding). Forming the length of the geocell is in cell-by-cell fastening of modules of a predetermined length to each other (for example, using a mechanical or electromechanical stapler) in a lateral direction to a length defined by a technological process. Also, it is possible to use any known method to produce an elongated geocell having a three-dimensional cellular structure in an expanded state.

It is necessary to provide for the possibility to fix the outermost areas of the geocell during its stretching, and for this purpose all the geocell bands which form a module after being fastened can have the same width excluding the second and last but one which are of a lesser width whereby one or two longitudinal pockets (above and below of the module) are formed along the module (the length of the geocell) following the first and before the last bands. These pockets are used for engagement while stretching the geocell and they are described in the analogue in detail. Other options of fixing the geocell edges by further engaging elements or applied pressure are also possible.

The manufactured length of the geocell is accommodated on a device for storing and transporting (spool, rack, package, box, coil and so on), transported to a site and installed on a carrier. Then the length of the geocell is stretched to the necessary size along a carryover conveyor from the device for storing and ridges of the device for expanding the geocell are inserted into the above-mentioned pockets.

One embodiment of a device for expanding the geocell comprises two horizontal cross members, for example, having a box-like construction and provided with ridges to be inserted into longitudinal pockets of the geocell. Cross members are on the same plane and can be rotated on vertical axes providing thereby the possibility to force them apart by an angle with relation to each other. Cross members can be forced apart manually or using mechanical, electrical or hydraulic drives. Rollers designed to guide the length of the geocell by its pockets to the ridges and/or for enhancing pulling-out the length of the geocell from the device for storage can be used in combination with cross members. The said rollers can be biased to the length of the geocell passing through it, have a surface of increased frictional properties and are provided with a power drive whose rotation is synchronized with the carrier movement speed.

The following improvements are considered essential:

- interconnection of geocell modules (sections) to form the length of geocell of a predetermined size for carrying out works on the geocell laying;
- the possibility to wind and store the length of the geocell on the spool;
- the use of longitudinal pockets in the length of the geocell allows connecting it with the device for expanding by inserting into the pockets of the cross member ridges designed for this purpose;
- forcing apart the cross members by an angle allows mechanical stretching of the geocell on a site under development to a width as defined by a technological process;
- if an end of the stretched geocell is fixed on the ground by anchoring pillars and the carrier continues its motion, the geocell will be stretched by force of the carrier, moving along the conveyor from the device for storage and sliding by the pockets on the ridges in the stretched state which can be kept by anchoring pillars installed at the edges of the stretched geocell or by ground filled in cells of the stretched geocell;
- conveyor (guideway) and rollers installed on the device enhance the arrangement of the geocell length movement for stretching, the rollers in case of using a drive whose rotation is synchronized with the carrier movement speed being able to enhance power pulling-out the length of the geocell from the device for its storage.

The technical substance of the technical solution as provided in this invention in respect of the power-operated process for the geocell's expansion is schematically shown on drawings illustrating an example of equipment for the geocell's expansion.

Fig. 1 – equipment for the geocell's expansion (top view).

5 Fig. 2 – sectional view taken along line A-A illustrating the arrangement of the geocell.

The technical solution according to the invention is illustrated by further drawings:

Fig. 3 – actuator;

Fig. 4 – spool.

An example of equipment for the geocell's expansion illustrated on Fig. 1 comprises
10 two cross members 1 and 2 fixed in a rotary manner so that they can move with respect to axes 3 and 4 at a predetermined angle. The cross members are fitted with ridges adapted for insertion into pockets of a length of the geocell. There are two pockets on each side of the length of the geocell (above and below) in this example. The length of the geocell is inserted into pockets while it passes guiding rollers 5 and 7. Roller 5 has power drive 6 (for example,
15 electrical or hydraulic drive gear). Roller 7 can be fitted with biasing device 8. Rollers 5 and 7 have surfaces with increased frictional properties and are supplied with a power drive and biasing device in accordance with the operating conditions of a carrier. Movement of the length of the geocell for the expanding step is implemented along a guideway, a chute of conveyor 9, restraints 10 being provided at danger points to prevent ejection of the length of
20 the geocell to the side. Pointed studs (anchor pillars) are used to fix the length of the geocell on the ground.

Expansion of the geocell is implemented as follows.

The laying machine is installed at the beginning of its working motion. Cross members 1 and 2 are unlocked from their transport position and, if this is envisaged by a manual, placed
25 on studs of axes of rotation 3 and 4 and fixed on them. The cross members are forced apart by mechanisms by an operating angle and fixed in this position. The length of the geocell is stretched along conveyor 9 between guiding rollers 5 and 7 and placed by its pockets on the cross member ridges or otherwise fixed on the guideway. The first few rows of cells of the stretched geocell are fixed on the ground by provisional anchoring pillars which should be
30 removed after the three-dimensional geocell is filled with free-flowing substance in accordance with operational procedures. The laying machine begins its working motion and concurrently the geocell being fixed on the ground is drawn from a storage device (spool) stretched (expanded) between the cross members forced apart and remains in a stretched position if its cells are being filled at the same time with a free-flowing substance or it is

being fixed along the edges by provisional anchoring pillars. In cases where the length weight is sufficiently large and a path of its movement for stretching is sufficiently long, the device can be fitted with guiding friction rollers having a power drive whose rate of rotation is consistent with the speed of the laying machine, the said guiding friction rollers enhancing pulling-out the length of the geocell. Conveyor 9 is provided with restraints 10 to prevent ejection of the three-dimensional geocell length to the side.

The solution according to the invention enables providing development of a surface segment by mechanized laying and stretching geocell modules. Therefore this solution allows increasing the rate of works on development of ground surface for various constructional purposes by substitution of using separate processes of stretching and joining geocell modules by a large number of workers for mechanized stretching the geocell length of a desired size previously formed and arranged on a carrier, for example, by action of the ridges being on the cross members of a stretching device on walls of longitudinal inner pockets formed between the outermost bands of geocell and ones connected thereto.

Further installation of a screw with opposite spiraling of a wing made of flexible material is possible to enhance the geocell stretching in the transverse direction.

Enhancing the transportation quality of the geocell along the conveyor is achieved also by using in the design of the geocell stretching device of guiding and pulling-out rollers having a power drive whose rate of rotation is consistent with the speed of the carrier (laying machine), the said rollers affecting the length of the geocell, and also by providing the conveyor for transportation of the length of the geocell with restraints preventing ejection of the moving length of the geocell to the side.

The quality of a geocell placed and filled with free-flowing substances (for example, sand-gravel aggregate) can be monitored using a geolocation method.

To store the geocell and carry out works on the geocell application it is proposed to use an equipment set consisting of a spool on which the geocell is stored and a device (actuator) for step-wise uniform winding and unwinding coils of the length of geocell. The said set is mounted on a carrier, namely, a laying machine (railroad machine, railroad flat-car, automobile, truck trailer and so on).

A length consisting of geocell modules connected to each other and disposed initially in the edgewise position is wound to the rotating spool, the length of the geocell passing the actuator being turned to the flat position, and advanced along the spool axis back and forth under the action of rollers of an actuator movable carriage performing uniform laying of coils. Movement of the spool and actuator is reversed during unwinding the length of the geocell

from the spool. The spool rotation rate during the unwinding process is synchronized with the geocell laying rate according to a number of coils remaining on the spool. Synchronization of spool rotation, actuator movement and also rotation of the mentioned rollers of the geocell expanding device can be controlled by an automatized system using optical linear and angular encoders to prevent excessive tension or loop formation.

The following enhancements are considered essential.

- geocell modules are joined to form a length of the geocell before the laying operation;
- storing the geocell on the spool enables mechanizing a continuous (as compared to module-by-module) process of geocell stretching on a site surface (as limited by the spool capacity);
- high spool capacity enables developing within a comparable time period a significantly larger area of the site (road, railroad bed and so on);
- use of the actuator enables implementing a qualitative and controllable process of winding the geocell to the spool and its unwinding to perform works.

The technical solution according to the invention is illustrated by further drawings:

Fig. 3 – actuator;

Fig. 4 – spool.

The actuator consists of guideway 11 along which carriage 13 with two passive rollers 14 (moving under action of the length of geocell passing through it) is moved by chain 12. Carriage 13 is operated by electric drive 15. Limit switches 16 regulate the restraining carriage movement back and forth. The spool comprises reel 17 rotating on frame 18 under the action of reversible electric drive 19.

The configuration of a set of devices mounted on the laying machine as proposed in the invention depends on its design and can differ in relative arrangement of components.

The laying machine operates as follows.

It is supposed that the length of the geocell has been formed and coiled or folded by another technologically reasonable method and the above-mentioned devices are mounted on the carrier. An end of the length of the geocell is passed through rollers 14 of the actuator, turned from the edge-wise position to the flat-wise position and fixed on reel 17 of the spool at a predetermined location. Carriage 13 of the actuator is set in an initial position. The spool and carriage are put in motion, the rate of rotation of reel 17 being synchronized with the speed of carriage 13 in order that the winding of the length of the geocell to the reel in the flat-wise position would be carried out uniformly without any overlapping and separation displacement of coils. After the whole length of the geocell is wound on the reel, the set of

equipment is stopped, movable parts are fixed in the transport position and the free end of the length of the geocell is attached to frame 18. The carrier (laying machine) is prepared to advance to the field of operations.

5 The set of devices of the laying machine as proposed in the invention enables accommodating on the carrier a large section of the geocell in a form prepared for use that increases the operating time of the carrier without reloading, i.e. increases its performance, allows mechanizing the geocell stretching process, enhances implementation of the geocell laying technological process, and enables reducing the amount of manpower.

10 Thus the geocell laying machine with advanced equipment for storing and expanding the geocell as proposed in the invention has a number of advantages relative to existing devices.

CLAIMS

1. A geocell laying machine, characterizing in that it comprises an equipment for storing and expanding the geocell, the said equipment including a spool rotating on a frame and designed to wind, store and unwind a length of geocell consisting of separate geocell modules of predetermined sizes connected in series, the spool being connected with an actuator providing control of uniform winding and/or unwinding the length of the geocell along the spool axis, means for advancing the length of the geocell along a guideway from the spool, at least two cross members that provide an expanding geocell and can be forced apart to form a predetermined angle between them, the cross members being connected with engaging means to hold the geocell's edges in the process of its expanding between the cross members.

2. The laying machine according to claim 1, characterizing in that the actuator further provides turning the length of the geocell to the flat position to enable winding to the spool.

3. The laying machine according to claim 1, characterizing in that the actuator further provides turning the length of the geocell to the edge position during its unwinding from the spool to enable advancing the length of the geocell along the guideway to the cross members.

4. The laying machine according to claim 1, characterizing in that the said means for advancing the length of the geocell comprise guiding and/or pulling-out rollers and a power drive whose rate of rotation is consistent with the speed of the laying machine to enable a uniform advancing of the length of the geocell.

5. The laying machine according to claim 1, characterizing in that the said means for advancing the length of the geocell comprise restraints to prevent its ejection from the guideway.

6. Equipment for storing the geocell, characterizing in that the said equipment comprises a spool rotating on a frame and designed to wind, store and unwind a length of geocell consisting of separate geocell modules of predetermined sizes connected in series, the said spool being connected with an actuator providing control of uniform winding and/or unwinding the length of geocell along the spool axis.

7. The equipment according to claim 6, characterizing in that movements of the spool and actuator are synchronized by an automatic control system.

8. The equipment according to claim 6, characterizing in that the actuator further provides turning the length of the geocell to the flat position during its winding to the spool.

9. The equipment according to claim 6, characterizing in that the actuator further provides turning the length of the geocell to the edge position during its unwinding from the

spool.

10. Equipment for expanding the geocell during its laying by means of a laying machine, characterizing in that the said equipment comprises a means for advancing a length of the geocell consisting of separate geocell modules of predetermined sizes connected in series
5 along a guideway, at least two cross members that provide for expanding the geocell and can be forced apart to form a predetermined angle between them, the cross members being connected with engaging means to hold the geocell edges in the process of its expanding between the cross members.

11. The equipment according to claim 10, characterizing in that it comprises guiding
10 and/or pulling-out rollers and a power drive whose rate of rotation is consistent with the speed of the laying machine to enable a uniform advancing of the length of the geocell.

12. The equipment according to claim 10, characterizing in that it comprises restraints to prevent the ejection of the length of the geocell from the guideway.

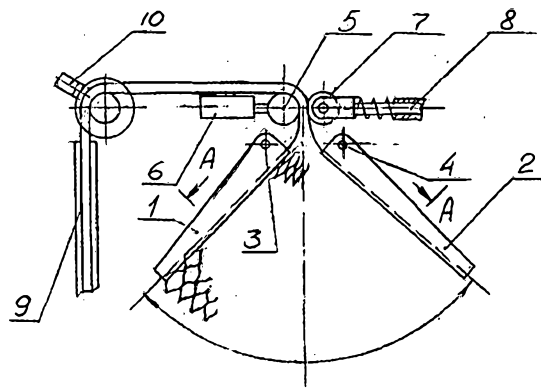

Fig. 1

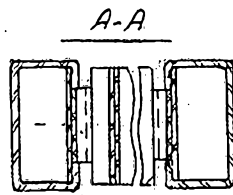

Fig. 2

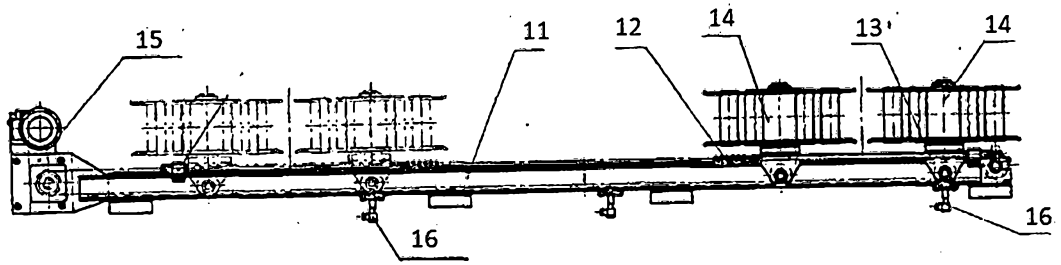

Fig. 3

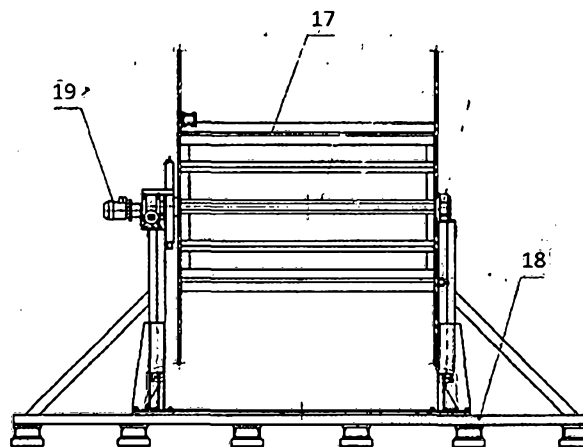

Fig. 4