

(19) World Intellectual Property Organization  
International Bureau



(43) International Publication Date  
4 September 2003 (04.09.2003)

PCT

(10) International Publication Number  
**WO 03/073659 A2**

- (51) International Patent Classification<sup>7</sup>: **H04H** **Palle**; Kronen 34, DK-9260 Gistrup (DK). **STRANGE, Jonathan, Richard**; White Gables, 7 Manor Road, Reigate, RH2 9LA (GB).
- (21) International Application Number: PCT/US03/05260
- (22) International Filing Date: 21 February 2003 (21.02.2003) (74) Agent: **HENRY, Steven, J.**; Wolf, Greenfield & Sacks, P.C., 600 Atlantic Avenue, Boston, MA 02210 (US).
- (25) Filing Language: English (81) Designated States (national): CN, JP.
- (26) Publication Language: English (84) Designated States (regional): European patent (AT, BE, BG, CH, CY, CZ, DE, DK, EE, ES, FI, FR, GB, GR, HU, IE, IT, LU, MC, NL, PT, SE, SI, SK, TR).
- (30) Priority Data:  
0204108.5 21 February 2002 (21.02.2002) GB  
10/331,623 30 December 2002 (30.12.2002) US
- (71) Applicant: **ANALOG DEVICES, INC.** [US/US]; One Technology Way, P.O. Box 9106, Norwood, MA 02062-9106 (US).  
Published:  
— without international search report and to be republished upon receipt of that report
- (72) Inventors: **ATKINSON, Simon**; The Dane, Wayside Walk, Heathfield, East Sussex TN21 0XW (GB). **BIRK,**  
For two-letter codes and other abbreviations, refer to the "Guidance Notes on Codes and Abbreviations" appearing at the beginning of each regular issue of the PCT Gazette.

(54) Title: 3G RADIO

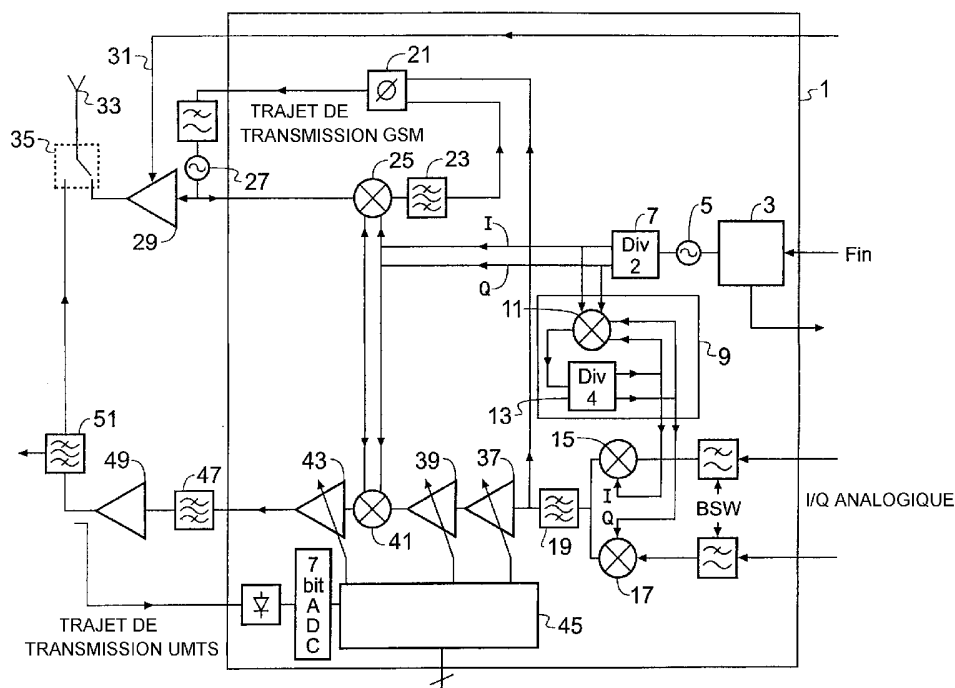

(57) Abstract: A dual mode transmitter for GSM and UMTS operation is provided. The GSM and UMTS paths share an oscillator and an intermediate frequency stage. Also, with the exception of the final stage of power amplification, the transmitter is provided as an integrated device.



WO 03/073659 A2

### 3G RADIO

The present invention relates to device architecture of mobile telephony units.

There are an emerging number of standards for cellular communication. For example, the  
5 European GSM system works in transmission bands known as GSM 850, GSM 900, GSM  
1800 and GSM 1900, where the numeric part of the name is indicative of the frequency of the  
band expressed in MHz. Furthermore, the UMTS system operates on a transmission band  
between 1.92 and 1.98 GHz. It would clearly be desirable if a telecommunications device  
could easily switch between these various telecommunications standards depending on which  
10 service it wished to use, or indeed which service was available.

According to a first aspect of the present invention, there is provided a transmitter for GSM  
and UMTS comprising: an in-phase/quadrature up-converter for mixing in-phase and  
quadrature inputs with an intermediate frequency; a GSM path including a phase locked loop;  
and a UMTS path;

15 wherein a frequency generator module is provided to generate a first signal at a  
frequency  $F_1$ , and the first signal is supplied as an input to an image reject mixer in the GSM  
path, to a mixer in the UMTS path, and as an input to divider which divides the first signal by  
three to create an intermediate frequency which is supplied to the in-phase/quadrature up  
converter; and wherein the image reject mixer in the GSM path is controllable to select either  
20 an upper or lower side band such that the GSM path operates at either  $(1+1/3)F_1$  or  $(1-1/3)F_1$ ;  
and wherein the mixer in the UMTS path selects the upper side band so as to have a output at  
 $(1+1/3)F_1$ .

It is thus possible to provide a transmitter arrangement operable in both the GSM bands, and  
the UMTS band in which many of the RF components are shared. Thus, for example, if the  
25 first signal from the frequency generator is in a band centred about 1.35 GHz, but extending  
as low as 1.28 GHz and as high as 1.485 GHz then it is possible to tune the transmitter  
to selectively operate in the GSM 850 and GSM 900 bands, and in the GSM 1800 and  
1900 bands and in the UMTS band between 1.92 and 1.98 GHz.

Advantageously the first radio frequency signal is in fact generated by a ultra high frequency  
30 voltage controlled oscillator working in the range of 2.565 to 2.97 GHz. This frequency can  
then be divided by 2 by a divider in order to ensure that the first RF frequency has an equal

mark space ratio. It will be appreciated by the person skilled in the art that transistor switching and logic technologies are now fast enough to operate at these frequencies. Furthermore, the divider can be arranged to produce in-phase and quadrature versions of the first radio frequency signal.

5 Advantageously the divider for generating the intermediate frequency (ie a local oscillator signal) is a regenerative divider which comprises two channels, one working on the in-phase signal and one working on the quadrature signal. Each channel has a mixer which receives the first radio frequency signal and a divide by 4 circuit which receives an output of the mixer and which itself provides an input to a respective second input of the mixer. The output of  
10 the divide by 4 divider is also provided to the respective in-phase and quadrature mixers. The feedback loop formed by the mixer and the divider by 4 divider in fact forms a divide by 3 mixer, as is known to the person skilled in the art.

Preferably the GSM transmission path comprises a phase sensitive detector having a first input for receiving an output of the in-phase/quadrature up-converter, and a second input for  
15 receiving an output of the image reject mixer in the phase locked loop. An output of the phase sensitive detector is provided to an input of a voltage controlled oscillator which in turn generates a radio frequency output signal. The output of the voltage controlled oscillator is provided to a further input of the image reject mixer. Because the image reject mixer receives both the in-phase and quadrature signals of the first signal, it can be electronically  
20 selected to output either the upper side band or the lower side band. Thus the phase locked loop can be selectively locked to a frequency of  $F_1$  minus the intermediate frequency or  $F_1$  plus the intermediate frequency.

The output of the voltage controlled oscillator in the GSM path is also provided to a high power amplifier which can be driven in Class C mode in order to obtain high efficiency.  
25 Driving the amplifier in Class C mode generates harmonics at multiples of the frequency of the voltage controlled oscillator. However it is apparent that these multiples are spaced apart by at least 850 MHz and therefore can be easily removed by relatively simple filtering.

The UMTS path may comprise one or more electronically controlled variable gain amplifiers serving to amplify the modulated intermediate frequency signal. The amplifiers typically  
30 only have to operate across a relatively narrow band of frequencies centred about the intermediate frequency, eg 450 MHz. The amplifiers can therefore be constructed to be

particularly linear. The output from the amplifiers is then mixed with the first signal by a single side band mixer in order to up-convert it to the UMTS output frequency in the range of 1.92 to 1.98 GHz. The output from the mixer may then be passed through a further variable gain amplifier giving around 25 to 30 dB of gain. The output of the amplifier may be passed  
5 through a surface acoustic wave filter before being supplied to a further off-chip power amplifier. A feedback path is also provided for sampling the output of the power amplifier, detecting the output level thereof, digitising it through an analog to digital converter and providing a measurement of the power output to a UMTS power control logic circuit.

It is thus possible, in a preferred embodiment of the invention, to provide a multi-mode  
10 transmitter operable in both UMTS and GSM transmission modes, the transmitter comprising:

- a. a signal input for receiving a signal (such as an I/Q baseband signal) to be upconverted by the transmitter;
- b. an oscillator for generating a first radio frequency signal having a frequency  $F_1$ , where  
15  $F_1$  is 1.5 or 0.75 times the desired carrier frequency  $F_C$ ;
- c. a first divider for receiving the first radio frequency signal  $F_1$  and dividing it by three so as to form an intermediate frequency local oscillator signal,  $I_F$ , having a frequency substantially at 0.25 or 0.5 times the desired carrier frequency;
- d. at least one mixer for mixing the signal from the signal input with the intermediate  
20 frequency local oscillator signal to create a modulated intermediate frequency signal;
- e. a GSM path responsive to the modulated intermediate frequency signal; and
- f. a UMTS path responsive to the modulated intermediate frequency signal;

wherein the GSM path comprises a voltage controlled oscillator within a phase locked loop, the phase locked loop including an image reject mixer receiving at a first input thereof the  
25 output of the voltage controlled oscillator, and at second inputs thereof in-phase and quadrature representations of the first radio frequency signal, such that it selectively outputs either the upper or lower side band as the signal to the phase sensitive detector within the phase locked loop; and

wherein the UMTS path comprises at least one variable gain amplifier and a mixer for  
30 mixing the first radio frequency signal with the modulated intermediate frequency signal and outputting one of the side bands to a further amplifier stage.

The oscillator may be followed by a divide by two stage such that in-phase and quadrature versions of the divided oscillator signal can be easily obtained. In such an implementation the oscillator frequency needs to be doubled to 1.5 or 3 times the desired carrier frequency.

According to a second aspect of the present invention, there is provided a direct conversion  
5 multi-mode receiver comprising electronically reconfigurable filters.

It is thus possible, by providing reconfigurable filters, to manipulate the output from the direct conversion multi-mode receiver such that it is suitable for additional processing operations to be performed on the signal in order to extract the data therein.

Advantageously the direct conversion multi-mode receiver also comprises offset generators  
10 which can be used to apply a controllable offset to a summer which is responsive to the output of the receiver.

In the direct conversion topology, it is highly desirable in order to be able to provide an offset to the output from the receiver. A reason for this is that the down conversion is performed by mixing the received radio signal, which is nominally centred about a frequency  $F_r$ , with a  
15 locally produced radio signal, also having a frequency of  $F_r$ . It therefore follows that the carrier of the received signal is down converted to a DC signal (or very near DC in the case of oscillator frequency mismatch). Any spurious DC offset (or low frequency signal) therefore needs to be subtracted from the output of the converter in order to reduce the dynamic range required of the subsequent processing circuitry, which in reality will comprise analog to  
20 digital converters such that further processing can then be performed in the digital domain. The act of removing the DC offset means that the dynamic range and resolution of the converters required can be reduced, therefore reducing the cost of the subsequent processing circuitry.

In a preferred embodiment, a direct conversion multi-mode receiver is provided which  
25 comprises at least one electronically reconfigurable filter arranged to filter a base band signal received from the receiver, and an offset generator, each of the reconfigurable filter and the offset generator is under the control of a control circuit such that the offset and filter response can be automatically controlled as a function of reception mode and signal conditions.

The filter may be implemented in hardware or software. Hardware implementations will tend to be preferred as they do not place so great a load upon post ADC processing resources.

According to a third aspect of the present invention, there is provided a hybrid filter exhibiting substantially uniform group delay in a pass band thereof, wherein the filter  
5 comprises a combination of a Chebychev and an inverse Chebychev response.

When designing an analog filter for communications applications, there are generally difficult trade-offs to be made between requirements for selectivity, group delay and complexity. Ideally, we want the physical delay for a signal passing through the filter to be uniform irrespective of its frequency content. Thus, in terms of a phase versus frequency graph, the  
10 phase delay needs to increase linearly with frequency.

In the context of telecommunications, and in particular UMTS communications, it is important that differential group delay be avoided as this can give rise to inter-symbol interference.

However, it is also generally necessary to obtain good selectivity, that is a rapid transition  
15 between the pass band and stop band.

It is well known that high Q filters that display good selectivity performance such as Chebychev and Elliptic filters often suffer in terms of differential group delay performance. On the other hand, filters that exhibit good differential group delay performance such as Butterworth and Bessel filters generally have inferior roll-off characteristics. The inventor  
20 has realised that combination of different filter characteristics can be arranged to give a desired response. The new filter design avoids the draw backs of conventional filter technologies and provides excellent selectivity, attenuation and differential group delay characteristics. The inventor has noted that the inverse Chebychev pass band characteristics are substantially identical to those of the Butterworth, but the filter contains stop-band zeros  
25 which give superior initial roll-off performance. On the other hand, the Chebychev filter has good initial roll-off characteristics and very high levels of ultimate attenuation.

Turning to the group delay characteristic, it is known to the person skilled in the art that at frequencies well below the cut-off frequencies, both the Chebychev and inverse Chebychev filters exhibit substantially uniform group delay. However, in the region of the cut-off

frequency the first derivative of the group delay for the two different filters has opposite signs. The inventor has realised that by combining the two characteristics it is possible to achieve substantial cancellation of the group delay characteristics in the region near the cut-off frequency. This cancellation can be arranged to be sufficient to ensure that by the time  
5 the group delay cancellation begins to fail, thereby resulting in undesirable group delay characteristics, the magnitude of the signals have been sufficiently attenuated at these frequencies such that they become relatively unimportant.

The hybrid filter represents a good choice for a reconfigurable switched band multi-mode filter whose modes of operation may place differing demands on the filter performance.  
10 Thus, in the context of a multi-mode receiver, one mode of operation may place stringent requirements on the filter in terms of differential group delay, but not such difficult requirements in terms of selectivity. The other mode of operation might have more stringent requirements in terms of selectivity, but less difficult requirements in terms of differential group delay. The hybrid Chebychev/inverse Chebychev filter proposed here is an effective  
15 solution for both requirements. In addition to band switching the filter, it is also possible to adjust the relative cut-offs of the two constituent filters further optimising performance in different modes of operation.

According to a fourth aspect of the present invention there is provided a dual mode single chip transceiver comprising a transmitter and a receiver, wherein frequency synthesisers are  
20 shared by the transmitter and the receiver, wherein the transmitter comprises an up-converter for receiving an input and up-converting it by mixing the input with a first synthesised frequency, and wherein in a GSM mode an offset phase locked loop is used to translate phase modulation at the up-converter output onto an RF carrier, and in a UMTS mode the up-converted signal is linearly amplified; and wherein the receiver comprises at least one direct  
25 down-converting channel for down converting the received signal.

It is thus possible to significantly reduce the implementation cost of a dual mode GSM/UMTS transceiver architecture by sharing many of the transmit and receive components within an integrated circuit.

Preferably the UMTS transmitter includes a further frequency up-conversion stage. Thus a  
30 first up-converter may produce an output at an intermediate frequency. The intermediate frequency may then be linearly amplified before being frequency up-converted to a final

output frequency. This final output frequency may then be passed to a power amplifier which is not integrated with the integrated circuit. The provision of one or more power amplifiers “off-chip” reduces the signal leakage between the transmitter path and the receiver paths.

This is particularly important as UMTS operates in full duplex mode and consequently signal leak through could have a degrading effect on receiver performance.

Preferably the UMTS duplex filter is also provided off-chip.

According to a fifth aspect of the present invention there is provided an automatic gain controller for a multi-mode homodyne receiver, the controller comprising an open loop controller responsive to a first signal for setting an initial gain, and a closed loop controller responsive to a measurement of signal power or amplitude for maintaining the signal power or amplitude at an output of the variable gain amplifier within a predetermined range.

It is thus possible to use an open loop controller to provide a rapid initial set up of the amplifier in order to bring it to roughly into a desired operational state, and then to “fine tune” the gain of the amplifier using a feedback loop. This enhances the set up time of the amplifier when changing mode.

UMTS radio systems require continuous full duplex operation. As part of this, automatic gain control (AGC) is required to maintain acceptable performance under varying signal level and channel conditions. The use of a homodyne architecture places certain constraints on the way in which the automatic gain controller can operate.

Homodyne receivers are susceptible to generating unwanted DC offsets in the in-phase/quadrature analog base band paths thereof. In order to maintain acceptable performance it is necessary to remove these DC offsets as they are indistinguishable from an on-channel signal. Under weak signal conditions, it is quite normal for the DC offset to be substantially larger in magnitude than the wanted signal. Thus, if the DC offsets were not removed, acceptable reception of the wanted signal is likely to prove impossible. A common approach to removing such offsets in wide band receivers is to use simple high pass filters or AC coupling (DC blocking) circuit arrangements.

Automatic gain control is achieved in homodyne receivers by adjusting the gain of analog base band amplifiers. However, adjusting the gain also adjusts the DC offset levels and thus

creates a transient settling time problem with high pass filters which were introduced in order to block the DC component. As a consequence, a low band-width automatic gain control loop is desirable in order to minimise transient effects as these would occur as a result of shifts in the DC offset. However a low band-width automatic gain control is incompatible  
5 with the requirement for initial rapid acquisition of the signal.

The inventor has realised that it is possible to overcome this with a combination of a “feed-forward” or open loop automatic gain controller and a feedback automatic gain controller.

The feed-forward/open loop controller can either set up its initial values based on an initial measurement of the signal power made by a suitable measuring device, such as a full wave or  
10 half wave rectifier located at a suitable place in the receiver, for example at the output of channel select filters, or alternatively the open loop controller may make an initial gain control setting based on the desired mode of operation of the receiver. The open loop controller only operates once, at each mode change, to set up the initial parameters of the variable gain amplifiers and other components which may require gain set up. From then on,  
15 control is passed to the closed loop which makes fine adjustments to the various gain levels.

According to a further aspect of the present invention, there is provided a homodyne receiver comprising a high pass filter having a variable time constant and a variable gain amplifier, the filter and amplifier being upstream of an analog to digital converter, wherein when a step  
20 change of the gain of the variable gain amplifier is implemented the time constant of the high pass filter is reduced for a predetermined time period.

According to a further aspect of the present invention, there is provided a homodyne receiver comprising at least one signal conditioner upstream of an analog to digital converter and a high pass filter having a variable time constant, wherein when the at least one signal  
25 conditioner is operated to cause a variation to be made to the signal supplied to the analog to digital converter, the time constant of the filter is set to a reduced value.

The highpass filter may be implemented downstream of the analog to digital converter and may therefore be implemented in the digital domain.

In a homodyne direct conversion receiver, it is necessary to use a high pass filter to remove DC offsets from the analog base band signal paths. For a 3.84 MHz UMTS signal, the cut-off

frequency for this high pass filter should be in the order of 10 kHz or so in order to remove the minimum level of the wanted signal energy. However, such a low cut-off frequency implies a long settling time for DC transients. The inventor has realised that the settling time for DC transients can be much improved if the cut-off frequency of the filter is temporarily  
5 increased. This significantly enhances the receiver settling time.

The present invention will further be described, by way of example, with reference to the accompanying drawings, in which:

Figure 1 is a circuit diagram schematically illustrating a combined GSM and UMTS transmitter, with shared RF components integrated into a single circuit;

10 Figure 2 is a schematic diagram of the direct conversion multi-mode receiver;

Figure 3 is a graph comparing the group delays of low pass Chebychev and inverse Chebychev filters versus frequency;

Figure 4 is a graph of the magnitude response of low pass Chebychev and inverse Chebychev filters versus frequency;

15 Figure 5 shows the combined magnitude response of the filters of Figure 4;

Figure 6 schematically illustrates a combined GSM/UMTS transceiver; and

Figure 7 schematically illustrates an automatic gain control.

Figure 1 schematically illustrates transmitter circuitry according to an embodiment of the first aspect of the present invention. The transmitter can be selectively operated as either a dual  
20 band GSM transmitter, or alternatively as a 3G UMTS transmitter. The transmitter comprises a single chip 1 on which is located a single radio frequency synthesiser 3. In accordance with an input signal  $f_{in}$  received by the synthesiser 3, the synthesiser controls a local oscillator 5 such that the oscillator 5 produces a substantially fixed frequency signal that is at either  $1\frac{1}{2}$  or 3 times the desired carrier frequency, depending on the actual desired operating frequency for  
25 the GSM or UMTS transmission path. It should be emphasised that the actual frequency of the signal generated by the general oscillator 5 does not substantially differ depending upon the band of transmission, only its ratio to the desired carrier frequency. The frequency of the signal generated by the local oscillator 5 may, for example, be approximately 2.7GHz and

more specifically in the range of 2.565 to 2.970 GHz. This corresponds to a modest adjustment of  $\pm 10\%$  (in fact around 7% in this example) of the frequency generated by the local oscillator.

The signal from the local oscillator 5 is then fed to a frequency divider 7 that divides the  
5 frequency of the signal by 2. The frequency divider 7 also allows the signal to be split into in-phase (I) and quadrature (Q) components. The I and Q components are fed into a further frequency divider 9 in the form of a regenerative divider that is arranged to divide the input frequency by 3. The divide by 3 frequency divider 9 comprises a frequency mixer 11 that receives the I and Q components of the input frequency signal and mixes them with  
10 corresponding components of the same signal that have been further frequency divided by 4 by a further frequency divider 13. The arrangement of the mixer 11 and divide by 4 divider 13 produces a divided by 3 frequency signal of the original input signal at the output of the divide by 4 divider 13. The I and Q components output from the divide by 3 divider 9 are therefore at  $\frac{1}{4}$  or  $\frac{1}{2}$  of the carrier frequency. Taking our example of the input frequency  $f_{in}$  of  
15 2.7GHz, the I and Q components at the output of the divide 3 divider 9 are at 450MHz.

The individual I and Q components are supplied to respective individual mixers 15 and 17 that each also receive the respective I and Q components of the analogue source signal. The mixers 15 and 17 act to combine the respective source signal components together with the I and Q components at 450MHz to generate a 450MHz modulated intermediate frequency  
20 signal which it then passed through a bandpass filter 19.

The intermediate frequency at the output of the bandpass filter 19 is then propagated along two individual signal paths, each path being used to generate respectively the GSM signal or the 3G UMTS signal.

For GSM, the 450MHz intermediate frequency signal is fed to a first input of a phase  
25 comparator 21. The second input of the phase comparator 21 also receives a 450MHz signal that is received from a bandpass filter 23. The input to the bandpass filter 23 is derived from an image reject mixer 25. The image reject mixer 25 receives as first inputs the I and Q components of the 1.35GHz signal that is obtained from the combination of synthesiser 3, local oscillator 5 and divide by 2 divider 7. The other input to the image reject mixer 25 is  
30 the carrier frequency signal that is generated by a voltage controlled oscillator 27 that is in turn controlled by the output from the phase comparator 21. The phase comparator 21,

voltage controlled oscillator 27 and image reject mixer constitute a phase locked loop that is used to translate the modulated intermediate frequency to the radio frequency carrier signal. The phase locked loop acts as a tracking bandpass filter and thus removes the need for an RF bandpass filter such as a SAW or ceramic filter that would otherwise be required to minimise out of band emissions.

The carrier frequency is substantially either 900MHz or 1.8GHz, depending upon the GSM band on which it is desired to transmit. The image reject mixer can selectively either subtract the 900MHz signal from the 1.35GHz I and Q component signals to arrive at the 450MHz signal input to the bandpass filters 23, or to subtract the 1.35GHz from the 1.8GHz carrier signal, thus also arriving at a 450MHz output. Thus the two signals input to the phase comparator 21 are always at 450MHz, i.e. the intermediate frequency. It is thus possible to cover the GSM 850/900 range and the GSM 1800/1900 range.

The modulated GSM signal is applied to a high power amplifier 29 that receives a power control signal on an input line 31. The output of the amplifier 29 is fed to an antenna 33 via a switch 35.

For 3G UMTS transmission, the intermediate frequency signal output from the bandpass filter 19 is fed through a pair of serially connected variable gain amplifiers 37, 39 prior to being mixed with the 1.35GHz signal derived from the local oscillator 5 and divide by 2 divider 7. The two signals are mixed at a single side band mixer 41 to produce a 1.8 GHz signal that is itself further amplified using a further single variable gain amplifier 43.

Amplifiers 37, 39 and 43 are controlled using a power control circuit 45 that receives a sampled and digitised input signal representative of the power of the transmitted output signal obtained via a tap at the output of amplifier 49. The 1.8GHz signal from the power amplifier 43 is passed through a UMTS RF SAW filter 47 and a further UMTS power amplifier 49 before being transmitted via the antenna 33. The signal is also passed through a duplexer and isolator unit 51 connected between the antenna and the UMTS power amplifier 49 which selectively allows a received signal at the antenna to be directed towards a receiver circuit.

The great advantage of the circuit described above is that a single RF synthesiser, running at 2.7GHz in the above example, is all that is required for the generation and transmission of both a dual mode (850/900 and 1800/1900) GSM signal and a 3G UMTS signal. The use of the dividers and mixers ensures that the desired carrier and output frequencies are always at

fixed multiples of the synthesiser frequency. Thus is possible to provide a combined dual mode GSM and 3G UMTS transmitter in a single circuit that has a relatively large number of common circuit components for both transmission paths.

Figure 2 schematically illustrates a direct conversion (also known as homodyne) multi mode receiver. The receiver comprises two channels, generally indicated 100 and 102 for convenience. Schematically, the channels are identical so only the first channel will be described in detail for convenience. However, in terms of operating performance, the channels may operate at different frequencies, for example around 800 to 1000 MHz for GSM 850 and GSM 900 and around 1.7 to 2.2 GHz for GSM 1800, GSM 1900 and UMTS.

In these circumstances the individual components of the channels may be tailored in order to operate at their respective bands. Each channel comprises a band pass filter 110 and 110a which serves to reject signals outside the pass band of the receiver. Thus, the filter 110 for the first channel 100 may be centred 900 MHz, whereas the filter 110a for the second channel 102 may be centred around 1.8 GHz or so. These filters are necessary to stop powerful out of band transmissions from driving the receiver into saturation. The output of the band pass filter 110 is provided to an input of an amplifier 112 whose output is provided to the first inputs of mixers 114 and 116, respectfully. Second inputs of the mixers 114 and 116 receive in-phase and quadrature versions of a locally generated carrier signal. The in-phase and quadrature versions of the signal are generated by a phase shifter 118 which itself receives the locally generated signal from the combination of a multi mode fractional synthesiser 120, a voltage controlled oscillator 122 and a multi mode fractional frequency multiplier 124. The components 120, 122 and 124 are shared by each of the channels 100 and 102. The mixers 114 and 116 mix the locally generated reference signal together with the received radio signal in order to form the difference frequency therebetween. Since both the radio frequency and the locally generated frequency are nominally at the same frequency, the information in the radio frequency is directly down converted to base band. The base band signal is provided at the output of each of the mixers 114 and 116. The outputs of the in-phase mixers 114 and 114a are provided to a first input of an in-phase summer 130 which is shared between both channels. Similarly, the outputs of the quadrature mixers 116 and 116a are provided to the first input of a quadrature summer 132 which is also shared between both channels. Each of the summers 130 and 132 is also connected to receive an offset signal generated by a respective digital to analog converter 134 and 136. The ability to provide an offset is

important since local oscillator coupling to the RF inputs could generate a DC offset, the size of which depends on both the magnitude and phase of the spuriously coupled signal with respect to the locally generated reference. The output of the summer 130 is provided to the input of an electronically controlled low pass filter 140 which in turn is followed by an electronically controlled variable gain amplifier 142. Similarly the output of the summer 132 is provided to an electronically controlled low pass filter 150 and a variable gain amplifier 152. The outputs of the amplifiers 142 and 152 are provided to respective analog to digital converters 160 and 162 whose digital outputs, after filtering in respective finite impulse response filters are provided to a signal processing and control unit 170. For each of the in-phase the quadrature channels, the control unit estimates the offset that is required for each of the channels and provides an offset signal to the digital to analog converters 134 and 136. The control unit 170 also sets up the filter characteristics of the switched filters 140 and 150 in the way appropriate to the operating mode of the receiver.

It is thus possible to provide a multi mode direct conversion receiver architecture as shown in Figure 2. The architecture has the advantage that much of the receiver hardware is reused for different modes of operation. The reuse of common hardware can provide a significant cost and power saving when compared with duplicating functionality as has hitherto been the case.

The analog base band sections are designed so that they can be reconfigured to meet the requirements of the various transmission systems. This means that the architecture must allow for the:

- i. reconfiguring of the gain line up,
- ii. reconfiguring of the channel filters
- iii. reconfiguring of the analog to digital converters speed and resolution, and
- iv. reconfiguring of the DC offset compensation

As noted hereinbefore separate radio frequency low noise amplifiers and in-phase/quadrature down converters are utilised as these need to be optimised for the frequency and mode of operation. Although in principle it is practical to have a reconfigurable RF front end for different modes of operation, it is believed to be more cost effective at the present time to have dedicated RF front ends.

As noted hereinbefore, it is highly desirable that the analog processing circuitry within a mobile telephone has filters included therein which can give both rapid attenuation between the pass band and the stop band, and which also exhibit good group delay, and specifically do not exhibit differential group delay so as to avoid inter-symbol interference. Figure 3 compares the group delays of an inverse Chebychev filter, represented by line 200, and the group delay of a Chebychev filter, represented by line 202, plotted as a function of frequency. Frequency units have been included on the ordinate of figures 3, 4 and 5 such that the various graphs can be easily compared. It will be seen that, in the example given in Figure 3, the inverse Chebychev group delay starts to increase for frequencies in excess of  $2 \times 10^5$  radians per second. However, the Chebychev group delay starts to decrease for angular frequencies in excess of  $2 \times 10^5$  radians per second and this decrease continues until the frequency  $10^6$  radians per second, then the Chebychev group delay increases sharply. It will be appreciated that in the limited region 204 where the group delays are of an opposite sign, partial cancellation of the group delay characteristics can be achieved thereby effectively extending the region 206 extending from low frequencies up to approximately  $2 \times 10^5$  radians per second where the group delays are essentially invariant with respect to frequency to an increased upper frequency of  $10^6$  radians per second.

Figure 4 schematically illustrates the magnitude response for the inverse Chebychev and Chebychev filters whose group delays were shown in Figure 3. It can be seen that the inverse Chebychev filter in this example has a substantially flat magnitude response up to approximately  $10^6$  radians per second, and then the magnitude response falls steeply towards a notch occurring at  $5 \times 10^6$  radians per second. At this point, the magnitude of the response is suppressed by over 60 dB. The Chebychev filter also has a substantially uniform magnitude response in the pass band, but has a roll over frequency of approximately  $2 \times 10^6$  radians per second from where the magnitude falls off rapidly.

Figure 5 shows the combined magnitude response of a Chebychev/inverse Chebychev filter using the individual filters shown in Figures 3 and 4. It is seen that the combined response 210 is substantially flat up to  $10^6$  radians per second and then falls steeply, being approximately 10 dB down by  $2 \times 10^6$  radians per second and over 60 dB down by  $5 \times 10^6$  radians per second. Furthermore, the group delay can be maintained as substantially constant up to  $1 \times 10^6$  radians per second.

It is appreciated by the person skilled in the art that analog filter design is an immensely complex mathematical exercise. It is, however, also well known that many filter designs have already been analysed and described in a normalised form such that an engineer can effectively use a “recipe” of a standard form to design a specific filter characteristic.

5 Furthermore, computer aided design packages now also allow for filter characteristics to be accurately depicted. For these reasons, the specifics of the design do not need to be described in detail as sufficient support exists in the prior art to enable the person skilled in the art to implement the filter. However, for the specific filters whose responses are shown in Figures 3 to 5, the Pole positions for Inverse Chebychev response were calculated by first calculating  
 10 the pole positions for Chebychev response and using pole reciprocation

$$p = \begin{bmatrix} 1.204 + 2.258i \\ 2.408 \\ 1.204 - 2.258i \\ -1.204 - 2.258i \\ -2.408 \\ -1.204 + 2.258i \end{bmatrix} \quad \text{Valid poles exist in the negative half of the S-plane}$$

$$z = \begin{bmatrix} 0 \\ 1.155i \\ 0 \\ 1.633 \cdot 10^{16}i \end{bmatrix} \quad \omega z := |z_1|$$

15 Position of stopband zero

The Inverse Chebychev Transfer function used was

$$20 \quad H_{ic} := \frac{\left[ \left( \frac{1}{p_3} \right) \cdot \left( \frac{1}{p_4} \right) \cdot \frac{1}{p_5} \right] \cdot \left[ \left( \frac{s_i}{\omega c} \right)^2 - (z_1)^2 \right] \cdot \left[ \left( \frac{s_i}{\omega c} \right)^2 - (z_3)^2 \right]}{\left[ \left[ \left( \frac{s_i}{\omega c} - \frac{1}{p_3} \right) \cdot \left[ \left( \frac{s_i}{\omega c} - \left( \frac{1}{p_4} \right) \right] \cdot \left[ \left( \frac{s_i}{\omega c} - \left( \frac{1}{p_5} \right) \right] \cdot \left[ (z_1)^2 \right] \cdot (z_3)^2 \right] \right] \right] \right]}$$

25 The Pole Positions for solution to Chebychev Polynomial were

- 16 -

$$p1 = \begin{bmatrix} 0.313+ 1.022i \\ 0.626 \\ 0.313- 1.022i \\ -0.313- 1.022i \\ -0.626 \\ -0.313+ 1.022i \end{bmatrix} \text{ Valid poles exist in the negative half of the S-plane}$$

The Chebychev Transfer Function used was

5

$$Hc_i := \frac{p1_3 \cdot p1_4 \cdot p1_5}{\left[ \left( \frac{s_i}{\omega_{cl}} - p1_3 \right) \cdot \left( \frac{s_i}{\omega_{cl}} - p1_4 \right) \left( \frac{s_i}{\omega_{cl}} - p1_5 \right) \right]}$$

The Transfer Function of Hybrid Filter is the combination of the two individual transfer functions:

10

$$X_i := (Hc_i \cdot Hic_i)$$

Being a hybrid filter, each of the two elements of the filter can be individually adjusted to better tailor the response of the filter to meet the needs of the particular application

15

For example, with the Chebychev response, it is possible to adjust the following:

1. The cut-off frequency
2. The filter order (number of poles)
3. The in-band ripple

20

For the Inverse Chebychev filter, it is possible to adjust the following:

1. The minimum stop-band attenuation
2. The maximum tolerable pass-band roll off
3. The relative frequency at which the minimum stop-band attenuation is reached
4. The filter order

25

The filter order can be adjusted by implementing the filter as a cascade of filter stages (ie the stages are connected one to another) whereby one or more stages can be switched out of the cascade such that they are bypassed. Thus bypassing a stage reduces the order of the filter.

30

Figure 6 schematically illustrates a dual mode GSM/UMTS transceiver constituting an embodiment of the present invention. The transceiver generally comprises a transmission channel 300 and a reception channel 302. Although represented in simplified form in Figure 6, the transmission channel 300 actually contains the dual mode transmitter shown in Figure 1 of the present drawings. In order to simplify the understanding of Figure 6, those parts of Figure 6 which are similar to parts shown in Figure 1 will be given like reference numerals thus, it can be seen that the transmitter receives a frequency synthesised signal from a synthesiser 3, that this synthesised signal is passed through a divide by three frequency divider 9 before being provided to the in-phase and quadrature mixers 15 and 17 of the up-converter. The output of the up-converter is, in a GSM mode supplied to a phase locked loop frequency shifter comprising a phase detector 21, a voltage controlled oscillator 27, a mixer 25 and a band pass filter 23. Thus the operation of these components is as described hereinbefore with reference to Figure 1. It may be noticed that there are further divide by two frequency dividers 306, 308 and 310 shown in the transmitter schematic, but it will be appreciated that these have little overall effect on the final operation of the transmitter, and in particular that frequency dividers 308 and 310 effectively nullify each other, although they do allow for the mark space ratio of the wave forms to be converted to an ideal 50-50. Similarly, the UMTS path comprises an array of linear amplifiers and a frequency up-converter. The components labelled 37, 39, 41 and 43 as shown in Figure 1 are schematically represented by the box 320 in Figure 6.

It will be appreciated that the receiver section 302 is a simplified representation of Figure 2. Here the multi-mode fractional frequency multiplier 124 of Figure 2 is also embodied within the dual fraction synthesiser 3 shown in Figure 6. It can also clearly be seen that two channels are provided, each having an in-phase and quadrature mixer for frequency down-converting the received signal to the base band. The components 130, 132, 134, 136, 140, 142, 150, 152, 160 and 162 of Figure 2 are schematically represented by the box 330 in Figure 6. It is clear that both the transmitter channels share components, both the receiver channels share components, and indeed that the receiver and transmitters share the frequency synthesiser components. This sharing of components allows for cost reductions in the final price of the integrated circuit, and also reduces the overall power consumption of the transceiver compared to implementations where each of these components are provided for their individual functions, and hence effectively duplicated.

GSM works on a time division duplex system and hence the transmitter and receiver are not operating concurrently. However UMTS operates on full duplex and consequently the transmitter and receiver do operate concurrently. In the UMTS mode it is important to limit the desensitisation of the receiver due to interactions with the UMTS transmitter. This is achieved firstly by not integrating the low noise power amplifier with the chip itself, and secondly by limiting the transmitter power at the transmitter output pins. Furthermore, it is important to ensure that the noise level in receive band at the transmit output is adequate. For example, with an external low noise amplifier having 13 dB of gain, the transmit power being limited to +3 dBm at the transmitter output pin and a transmit noise floor in the receive band of -140 dBc/Hz if isolation of 30 dB is obtained between the transmitter and receiver then the impact of the transmitter on receiver sensitivity will be approximately 0.1 dB.

The architecture shown in Figure 6 is operable in several modes, the frequency plan for the transceiver may be as follows:

GSM 850/900 receive mode - the synthesiser frequency is three times the RF frequency.

GSM 1800/1900 receive mode - the synthesiser frequency is 1.5 times the carrier frequency.

UMTS receive mode - the synthesiser frequency is 1.5 times the RF carrier frequency.

GSM 850/900 transmit mode - the synthesiser frequency is 3 times the RF carrier frequency and the intermediate frequency is a  $\frac{1}{2}$  of the RF carrier frequency.

GSM 1800/1900 transmit mode - the synthesiser frequency is 1.5 times the RF carrier frequency and the intermediate frequency is  $\frac{1}{4}$  of the RF carrier frequency.

UMTS transmit mode - the synthesiser frequency is 1.5 times the RF carrier frequency and the intermediate frequency is  $\frac{1}{4}$  of the RF carrier frequency.

Figure 7 schematically illustrates a hybrid feed forward and feed back automatic gain control system constituting an embodiment of the present invention. The circuit diagram shows a variable gain amplifier whose output is supplied to the hybrid Chebychev/inverse Chebychev filter, generally indicated 402, which has hereinbefore been described. An output of the hybrid filter 402 is provided to the input of a further variable gain amplifier which is schematically represented as three independently electronically controllable variable gain amplifiers 404, 406 and 408 which together serve to provide a variable gain between zero and

54 dB in one dB steps. An output of the final amplifier 408 is provided as an output 410 from the automatic gain controller.

The feed forward controller, generally indicated 420, comprises a received signal strength indicator (RSSI) log strip which has an input connected to the output of the hybrid filter 402.

5 The RSSI log strip is used to estimate the signal strength at the output of the hybrid filter.

The RSSI log strip 422 produces as an output thereof 424 a voltage which is substantially linearly proportional to the composite power of the signal at the output of the filter expressed in dBm. This output signal is filtered by a low pass filter 426 before being supplied to the

10 the analog input 428 of a six bit analog to digital converter 430. The signal at the input 428 of

the analog to digital converter 430 is digitised in response to a "start convert" signal and the output of the conversion is supplied to a filter gain logic controller 432. The filter gain logic

controller has two outputs, one of which is supplied to a register 434 for controlling the gain

of the variable gain amplifier 400, whilst the other output is supplied as a 6 bit word to a 6 bit

updown counter 440. Thus, the counter can be loaded with the output of the filter gain logic

15 controller 432.

The signal in a UMTS receiver is a composite of the wanted signal, noise and any residual interfering signals. This composite signal appearing at the output of the hybrid filter 402 is

digitised to produce a digital word that has the characteristic of "A" dB per bit, where A

represents an arbitrary number. This control word is used to set the gain of the variable gain

20 amplifiers. The variable gain amplifiers are designed to have a gain reduction characteristic

of "A" dB per bit. As such, if the signal level into the receiver increases by 5 A dB, then the

digitised control word will also increase by 5. This in turn will result in the reduction of the

gain of the variable gain amplifiers 404, 406 and 408 by a composite gain amounting to 5A

dB. Thus the signal level at the output of the variable gain controller 410 is kept substantially

25 constant. Because the approach described so far uses feed forward techniques, there are no

band-width implications that might affect a feed back system. Thus, it is possible to rapidly

set up gain for the automatic gain controller for example when switching modes of operation

or channels. Having rapidly acquired the composite signal level and setting up an initial gain,

further gain control is performed by a feedback scheme.

30 The feedback controller, generally indicated 450, comprises a rectifier 452 connected to the

output of amplifier 408 in order to deduce a rectified signal representing the signal power at

the output of the amplifier 408. The signal from the rectifier 452 is low pass filtered by a filter 454 before being supplied to the inputs of a window comparator 456 which, as recognised by the person skilled in the art, compares the signal at the input therein with high and low thresholds defining a window and produces an output 458 which is indicative of whether the signal is below the window threshold or above the window threshold. The signal 5 458 is provided to a count direction control input (up/down input) of the counter 440. As shown in Figure 7, the window comparator 456 is also configured to provide an output which indicates when the input thereto is within the bounds defining the window, and this output is sent to an AND gate 460 which serves to gate the provision of a clock signal to the counter 10 440. Thus, when the output 410 is within the power band defined by the window comparator 456, the counter 440 is inhibited from receiving its clock signal. The clock signal 462 is also ANDed with an "enable feedback" signal at an AND gate 464 which gives overall control of whether the feedback loop should operate or not. The output of the AND gate 464 is provided to an input of the AND gate 460, the output which is connected to the clock pin of 15 the counter 440. The output of the counter 440 is provided to a gain decoder 470 which in turn sets the gains of the amplifiers 404, 406, and 408.

In use, the signal level detector and window comparator is used to ensure that the composite signal level and the amplifier outputs is kept within a narrow range, for example +/-0.5 dB. If the composite signal level is above the threshold of the window comparator, the up/down 20 counter is enabled and the gain is adjusted on every clock cycle. As such, the clock sets the time constant of the feedback loop. If the composite signal level is below the window comparator threshold, then the up/down counter is also enabled, but this time counts in the opposite direction. As a consequence, the feedback loop will act to always ensure that the composite signal level is tightly controlled and adjusted at a rate determined by the frequency 25 of the clock 462.

Referring to Figure 2, it should be noted that every time a gain control adjustment is made or an offset correction is made, this step change can result in a transient DC offset appearing at the output of the filter. The DC offsets could be removed by a high pass filter, but for a truly generic receiver it is better that the DC offset correction should be performed in the digital 30 domain. Thus at each gain change a new DC offset is estimated and the estimate is supplied to the converters 134 and 136 such that a correction is added at the summers 130 and 132. This said, the transient occurring as a result of gain change still has an unwanted effect of the

low pass filters 140 and 150. This transient decays in time, but during the settling time of the filter the homodyne receiver is effectively blinded. This is because the conversion range of the analog to digital converter will necessarily be limited, and the offset may cause the converter to have to convert outside its nominal operating range.

- 5 Given that the receiver is effectively non-functional during this transient period, the inventor has realised that it is permissible to change the filter characteristics during the short period in order to allow for a more rapid settling time. Thus, when a change in gain or offset is implemented, the high pass filter is simultaneously, or near simultaneously set to a wide bandwidth such that the DC transient will quickly settle. The settling time can be estimated
- 10 from known characteristics of the filter. After the settling time, the filter is automatically switched back to the nominal required setting for its proper operation. The afilter can be under the control of a timer, for example implemented as a monostable, which alters the filter characteristics for a brief but well defined period. This technique ensures the fastest possible receiver settling time whilst at the same time minimising the amount of wanted modulation
- 15 energy that might be removed by the high pass filter. A typical ratio between the two bandwidth settings might be in the order of 10 to 1, although this is only a non-limiting example and other ratios may be chosen by the design. The implementation of this technique is not dependent on the filter technology. Thus the filter might be implemented as a switched capacitor filter, a switched bandwidth active R-C filter, gyrator- capacitor filter and so on.
- 20 The specific implementation of the filter is within the knowledge of the person skilled in the art.

It is thus possible to provide a multi mode receiver and transceiver which are particularly suited for use in mobile telephony.

CLAIMS

1. A transmitter for GSM and UMTS comprising  
an in-phase/quadrature up-converter for mixing in-phase and quadrature inputs  
5 with an intermediate frequency local oscillator signal;  
a GSM path including a phase locked loop; and  
a UMTS path;  
wherein  
a frequency generator is further provided to generate a first signal at a  
10 frequency  $F_1$ , and  
the first signal is supplied as an input to an image reject mixer in the GSM  
path, to a mixer in the UMTS path, and as an input to divider which divides the first signal by  
three to create an intermediate frequency local oscillator signal which is supplied to the in-  
phase/quadrature up converter;  
15 and wherein the image reject mixer in the GSM path is controllable to select  
either an upper or lower side band such that the GSM path operates at either  $(1+1/3)F_1$  or  $(1-1/3)F_1$ ; and wherein the mixer in the UMTS path selects the upper side band so as to have a  
output at  $(1+1/3)F_1$ .
2. A transmitter as claimed in claim 1, in which the frequency generator is tuneable.
- 20 3. A transmitter as claimed in claim 2, in which the frequency generator is tuneable over  
a range of 10% with respect to a centre frequency.
4. A transmitter as claimed in claim 2, in which the frequency generator is tuneable to  
have an output frequency in the range 2.56 to 2.97 GHz.
5. A transmitter as claimed in claim 1, wherein the frequency generator includes a local  
25 oscillator, an output of which is provided to a divide by two counter which generates first and  
second frequency divided representations of the output of the local oscillator, the second  
frequency divided representation being  $90^\circ$  out of phase which respect to the first frequency  
divided representation.
6. A transmitter as claimed in claim 5, in which the first and second frequency divided  
30 representations constitute the first signal.

7. A transmitter as claimed in claim 1, in which the first signal comprises an “in-phase” signal and a “quadrature” signal.
8. A transmitter as claimed in claim 1, in which the divide by three divider acts independently on the in-phase and quadrature components of the first signal.
- 5 9. A transmitter as claimed in claim 1, in which the divide by three divider is a regenerative divider.
10. A transmitter as claimed in claim 1, in which the intermediate frequency is substantially 450 MHz.
11. A transmitter as claimed in claim 1, in which the in-phase and quadrature inputs are  
10 up converted to the intermediate frequency and then combined prior to being made available to the GSM path and the UMTS path.
12. A transmitter as claimed in claim 1, in which the GSM path comprises a phase sensitive detector having a first input arranged to receive a modulated intermediate frequency signal and an output connected to a frequency control input of a voltage controlled oscillator;  
15 an output of the oscillator being supplied to an antenna path and also to a signal input of the image reject mixer; and wherein an output of the image reject mixer is supplied to a second input of the phase sensitive detector.
13. A transmitter as claimed in claim 1, in which in the GSM mode a carrier frequency is substantially 900 MHz or 1.8 GHz and the image reject mixer is arranged to either add or  
20 subtract a substantially 450 MHz intermediate frequency signal from a substantially 1.35 GHz signal generated by the frequency generator.
14. A transmitter as claimed in claim 1, wherein the UMTS path comprises an up converter for forming a signal whose frequency is the sum of intermediate frequency and the signal generated by the frequency generator.
- 25 15. A transmitter as claimed in claim 1, in which the UMTS path operates at substantially 1.8 GHz.
16. A transmitter as claimed in claim 1, in which the frequency generator, the divider for generating the local oscillator signal, the GSM path and the UMTS path are, with the

exception of power amplifier stages for the GSM and UMTS paths, integrated into a single integrated circuit.

17. A transmitter as claimed in claim 1, in which the transmitter is integrated into a single integrated circuit.

- 5 18. A multi-mode transmitter operable for UMTS and GSM transmissions, comprising:
- a. a signal input for receiving a signal to be up converted on to a carrier signal by the transmitter;
  - b. an oscillator for generating a first radio frequency signal having a frequency  $F_1$ , where  $F_1$  is 1.5 or  $\frac{3}{4}$  times a desired carrier frequency  $F_C$ ;
  - 10 c. a first divider for receiving the first radio frequency signal  $F_1$  and dividing it by three so as to form an intermediate frequency,  $I_F$ , having a frequency substantially at 0.25 or 0.5 times the desired carrier frequency;
  - d. at least one mixer for mixing the signal from the signal input with the intermediate frequency local oscillator signal to create a modulated intermediate frequency signal;
  - 15 e. a GSM path responsive to the modulated intermediate frequency signal; and
  - f. a UMTS path responsive to the modulated intermediate frequency signal;

wherein

the GSM path comprises a voltage controlled oscillator within a phase locked loop, the phase locked loop including an image reject mixer receiving at a first input thereof  
20 the output of the voltage controlled oscillator, and at second inputs thereof the first radio frequency signal, such that it selectively outputs either the upper or lower side band of the mixing of the signals supplied to it as a signal in the phase locked loop; and

wherein

the UMTS path comprises at least one variable gain amplifier and a mixer for  
25 mixing the first radio frequency signal with the intermediate signal and outputting one of the side bands of the mixing process.

19. A transmitter as claimed in claim 18 in which the oscillator is tuneable.

20. A transmitter as claimed in claim 19, in which the oscillator is tuneable over a range of substantially 10% with respect to a nominal centre frequency.

21. A transmitter as claimed in claim 18 in which the oscillator is associated with a divider so as to produce in-phase and quadrature signals.
22. A transmitter as claimed in claim 21, in which the in-phase and quadrature signals have a frequency  $F_1$ .
- 5 23. A transmitter as claimed in claim 18, in which the first radio frequency signal comprises an in-phase signal and a quadrature signal.
24. A transmitter as claimed in claim 23, wherein the in-phase and quadrature signals are frequency divided to generate in-phase and quadrature local oscillator signals.
25. A transmitter as claimed in claim 18, wherein the transmitter is provided as part of an  
10 integrated circuit.
26. A transmitter as claimed in claim 18, wherein, with the exception of output power amplifiers, the transmitter is provided as part of an integrated circuit.
27. A mobile telephone including a transmitter as claimed in claim 1 or 18.
28. A mobile telephone as claimed in claim 18, wherein a receiver is provided, and the  
15 receiver is a homodyne receiver and receives the signal  $F_1$  for performing down conversion.
29. A transmitter for use in mobile telephony, the transmitter comprising a first transmitter portion for performing phase or frequency modulation, and a second portion of performing at least amplitude modulation, and wherein the first and second transmitter portions are provided with a first locally generated radio frequency signal from a shared  
20 oscillator such that the output frequency of the first and second portions is determined by the locally generated radio frequency signal.
30. A transmitter as claimed in claim 29, wherein the transmitter further includes an intermediate frequency generator for generating an intermediate frequency signal the frequency of which is related to the first locally generated radio frequency signal.
- 25 31. A transmitter as claimed in claim 30, in which the intermediate frequency signal is proportional to the first locally generated radio frequency signal.

32. A transmitter as claimed in claim 30, in which the first locally generated radio frequency signal is resolved into an in-phase signal and a quadrature signal, the intermediate frequency signal is similarly resolved into an in-phase signal and a quadrature signal, and the transmitter further includes an up converter having in-phase and quadrature paths for up-  
5 converting an input to the intermediate frequency.

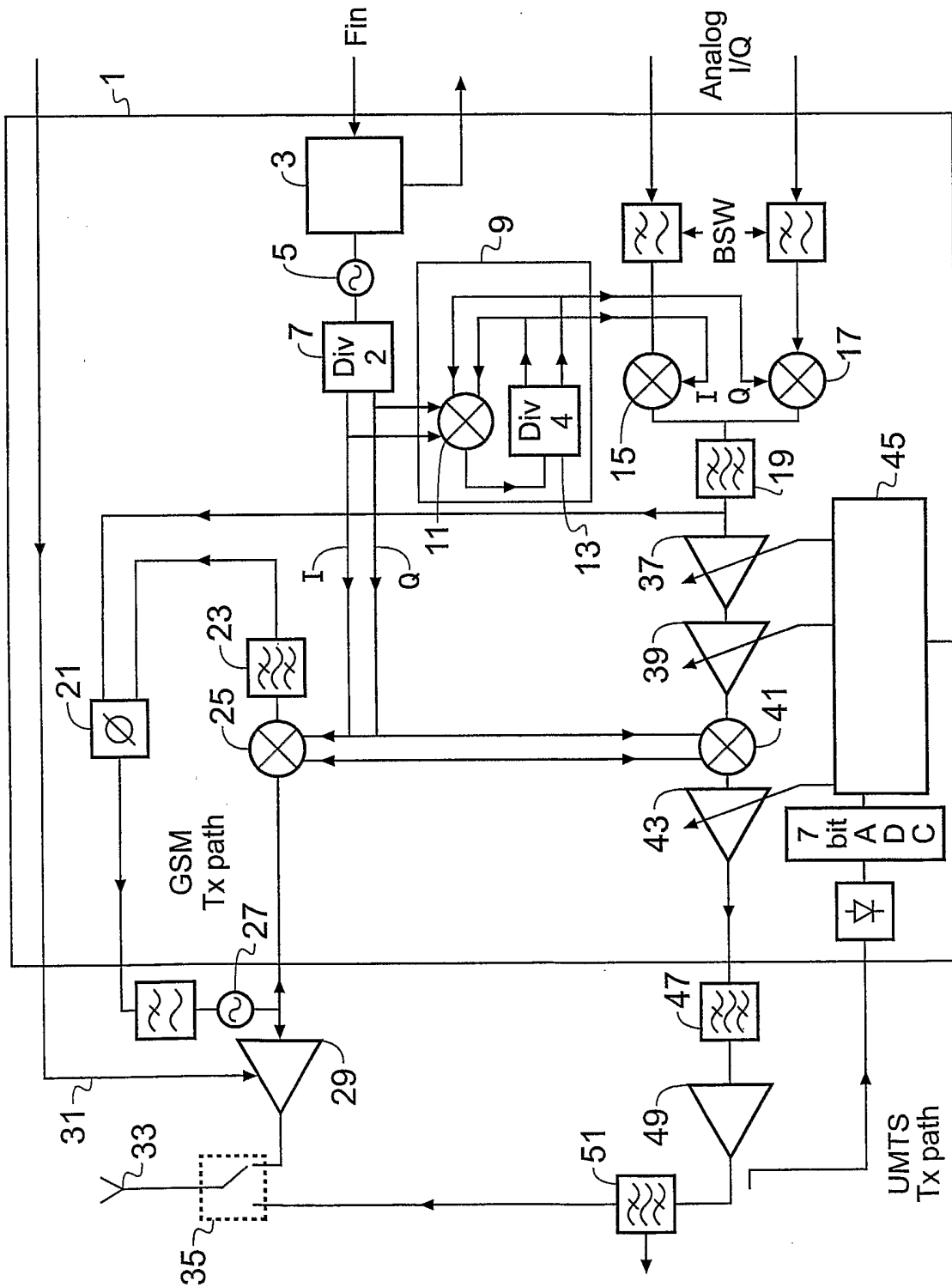

Fig. 1

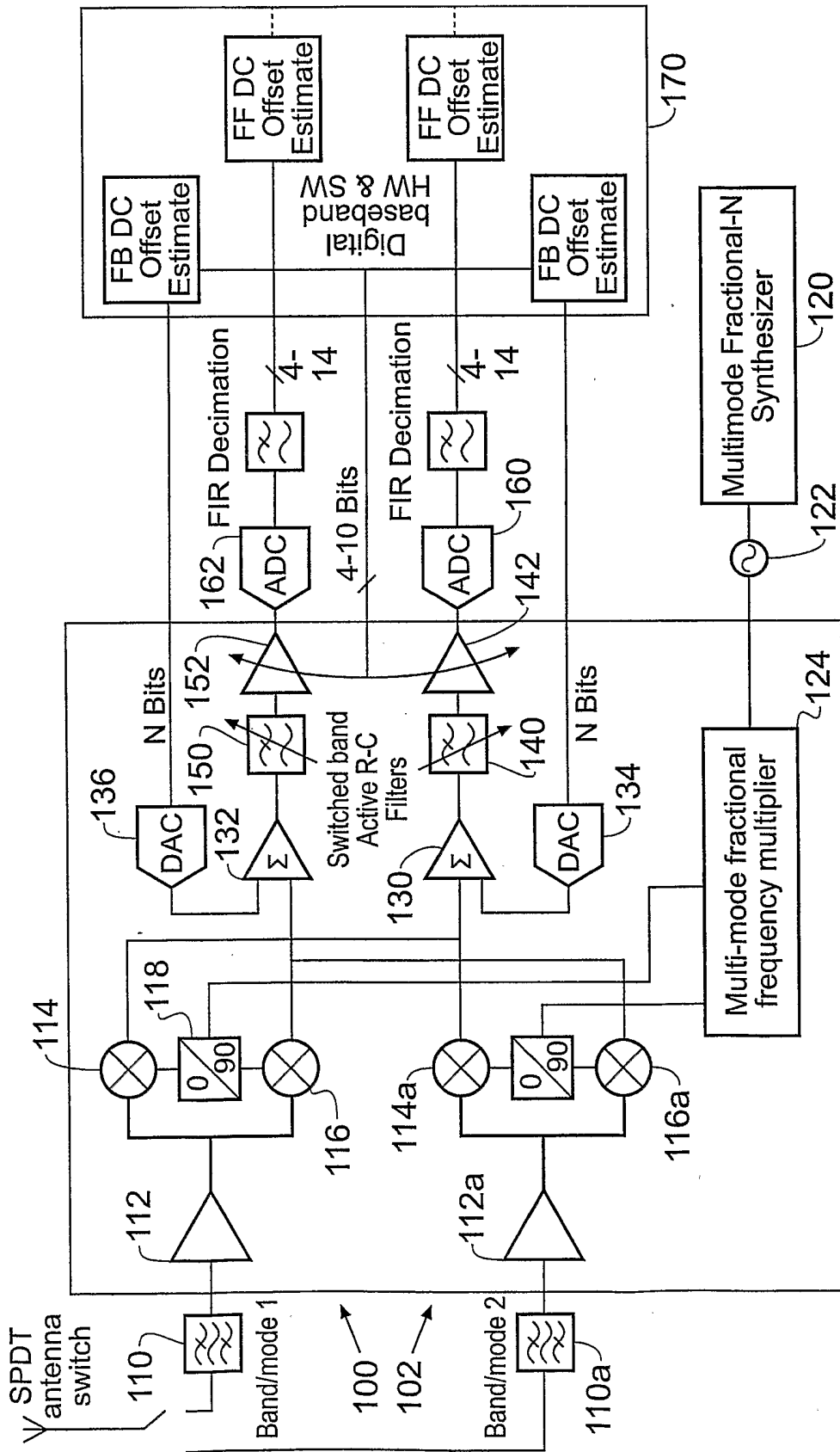

Fig. 2

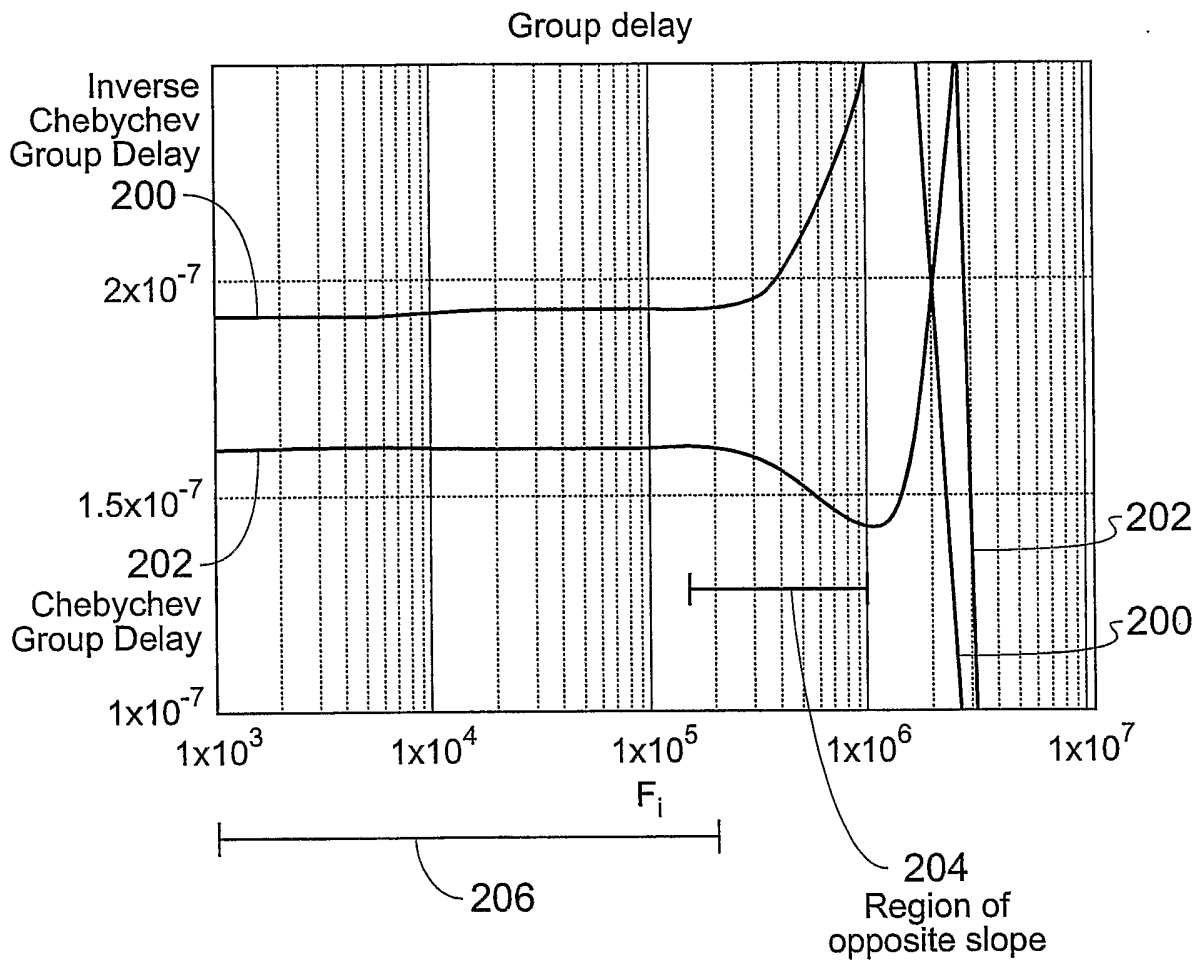

Fig. 3

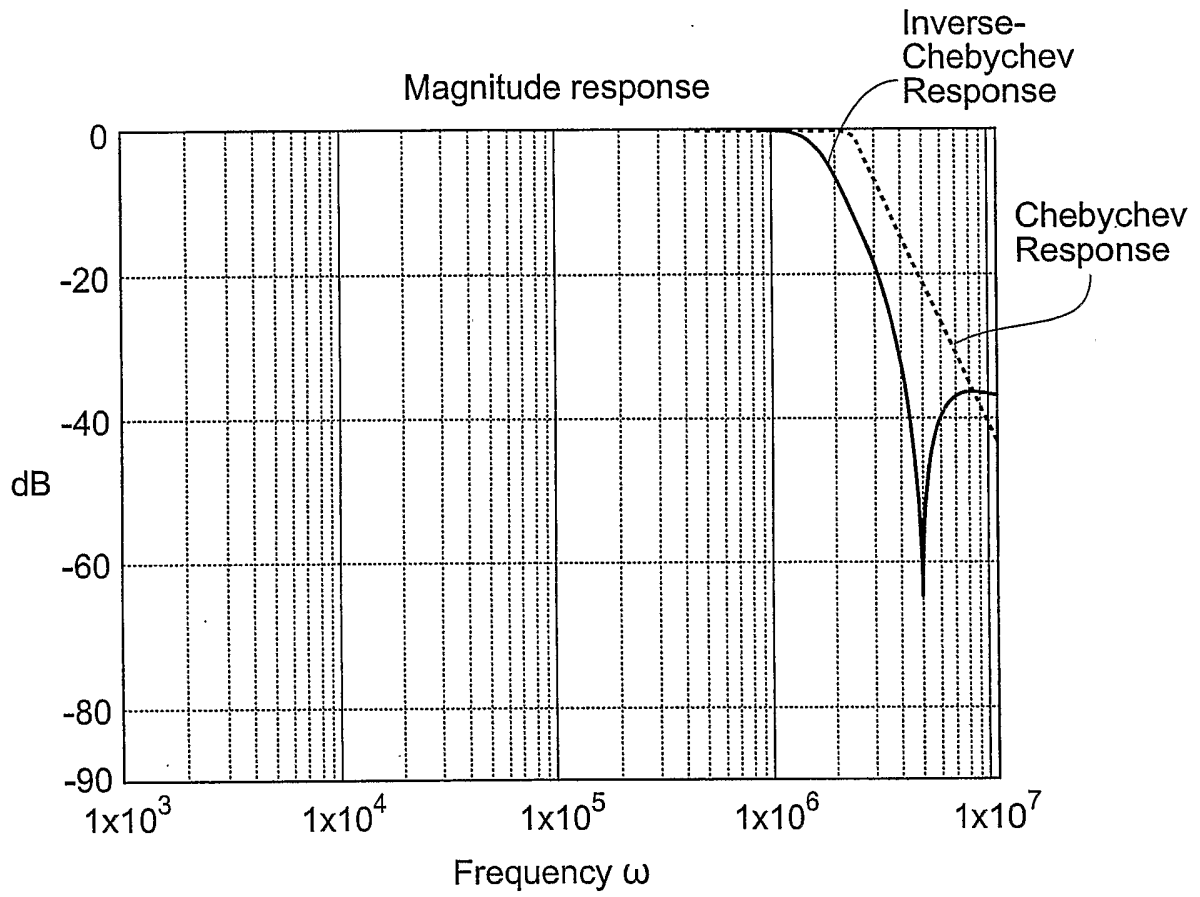

Fig. 4

5/7

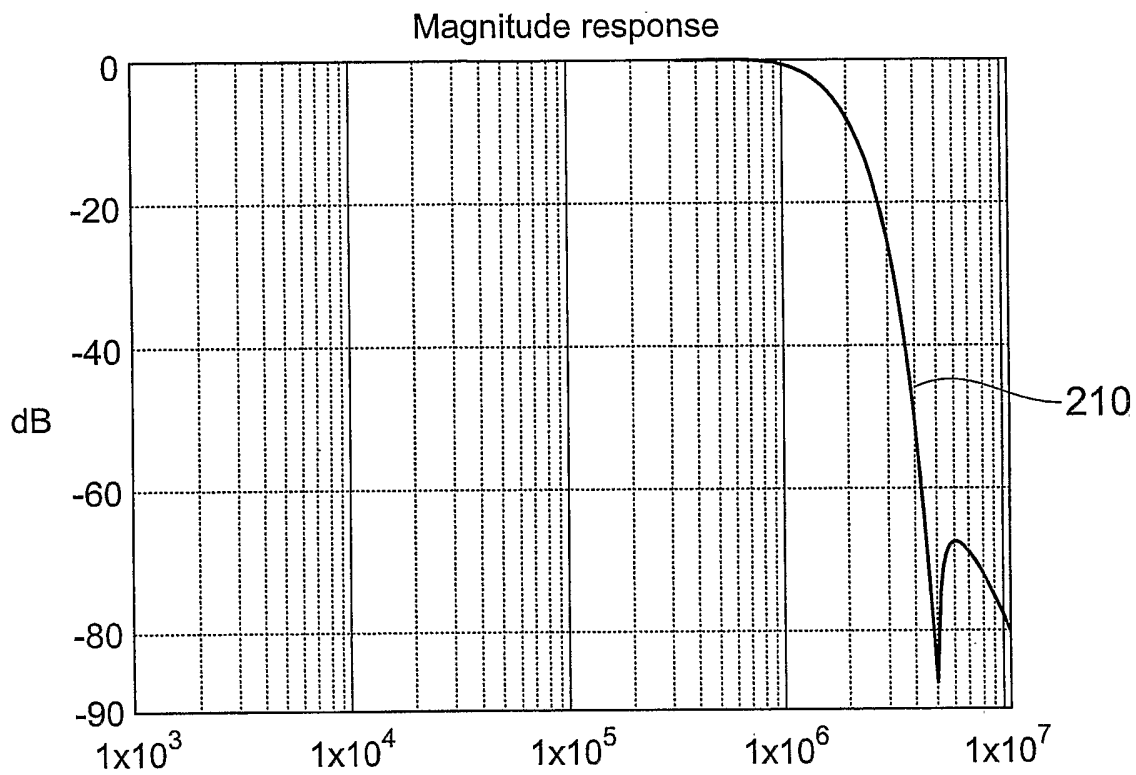

Fig. 5

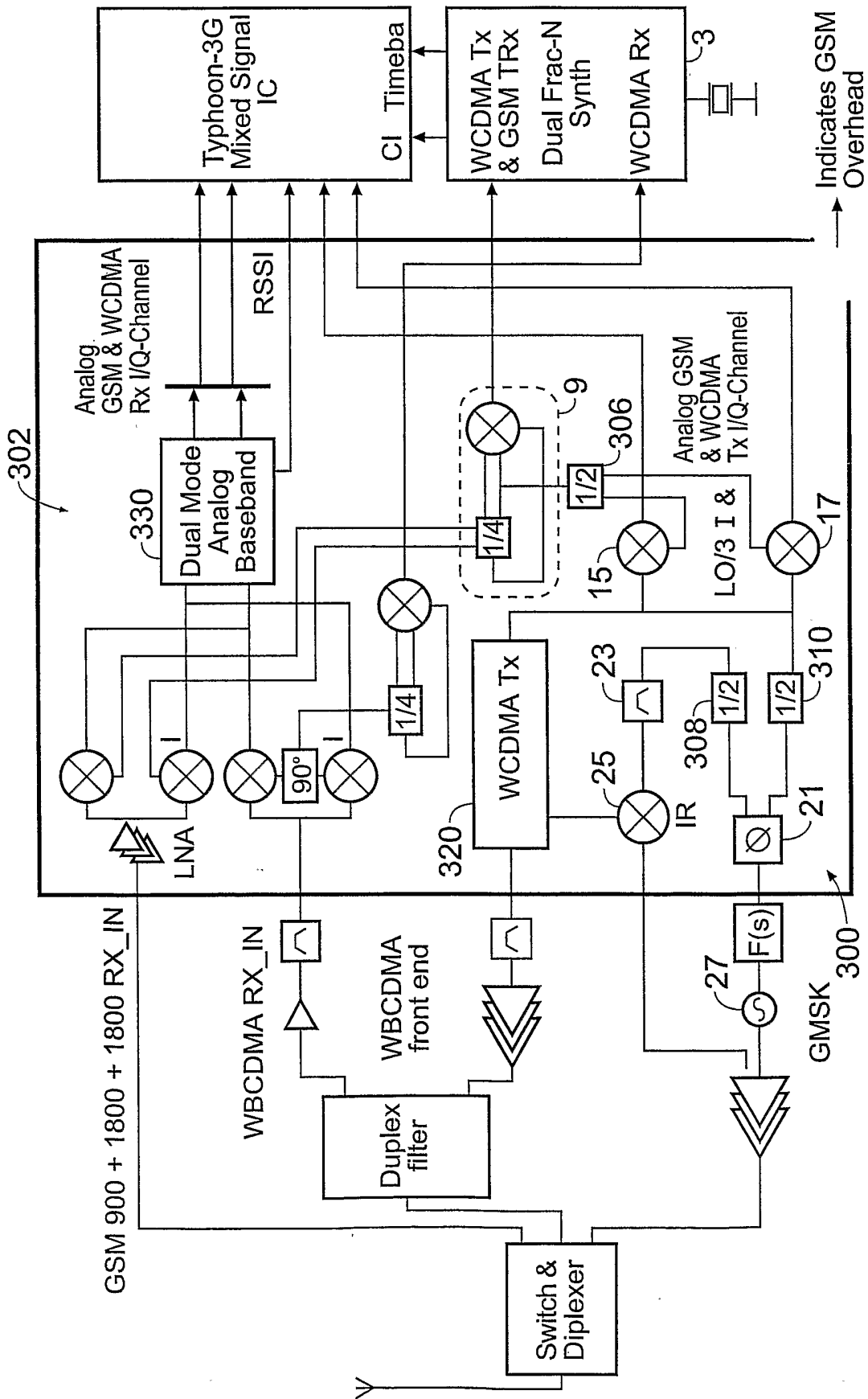

Fig. 6

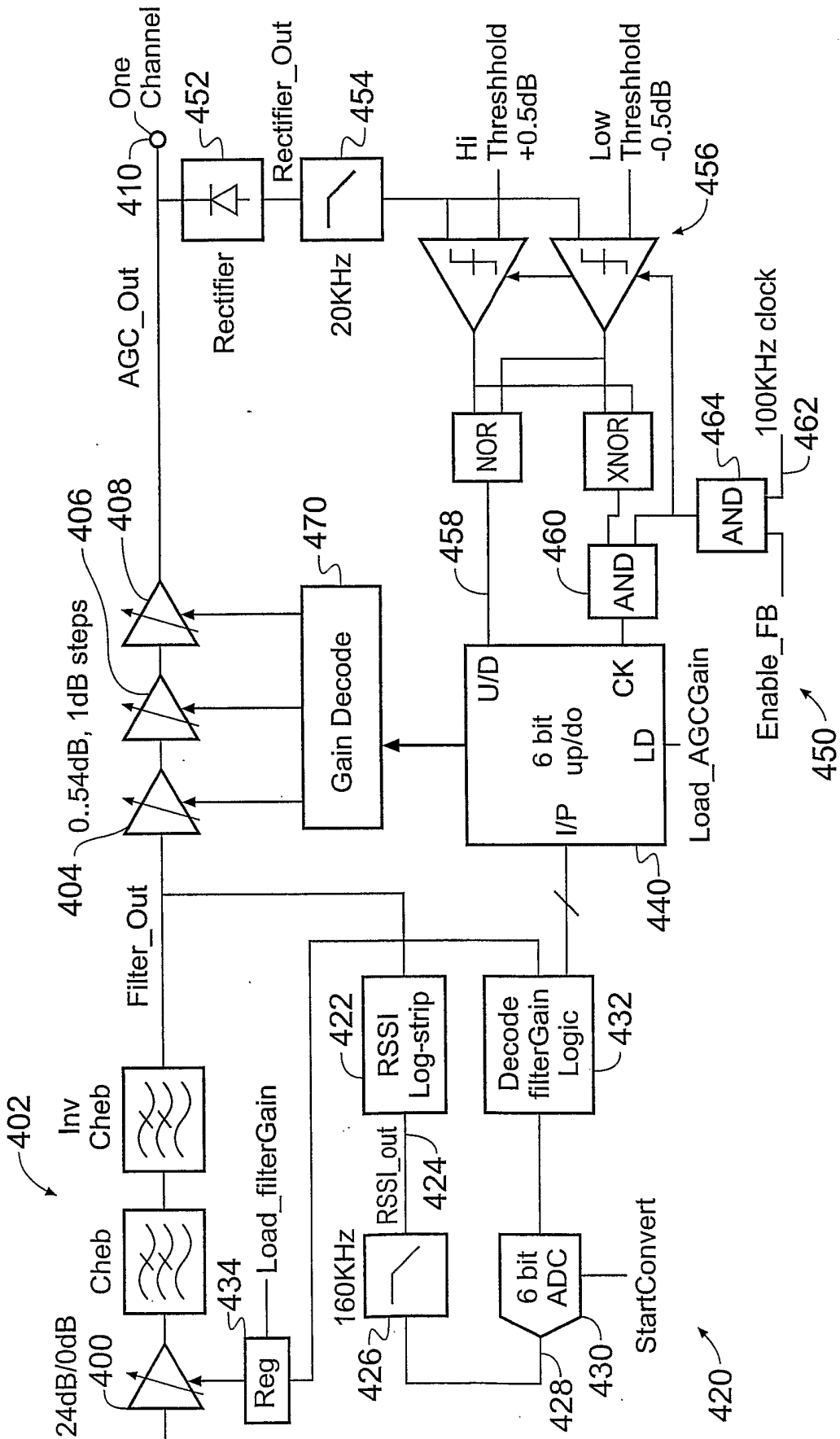

Fig. 7