



(12) EUROPEAN PATENT APPLICATION

(43) Date of publication:
15.11.2006 Bulletin 2006/46

(51) Int Cl.:
B24B 7/22 (2006.01)

(21) Application number: 06009404.2

(22) Date of filing: 08.05.2006

(84) Designated Contracting States:
AT BE BG CH CY CZ DE DK EE ES FI FR GB GR
HU IE IS IT LI LT LU LV MC NL PL PT RO SE SI
SK TR
Designated Extension States:
AL BA HR MK YU

(71) Applicant: Master Tre S.R.L.
37010 Cavaion Veronese VR (IT)

(72) Inventor: Erio, Fidanzi
20148 Milan (IT)

(30) Priority: 09.05.2005 IT MI20050828

(74) Representative: Coloberti, Luigi
Via E. de Amicis No. 25
20123 Milano (IT)

(54) Abrasive tool for surface treatment on marbles, stones and the like

(57) The abrasive tool (10) for surface treatment operations on marbles, stones and the like, comprises a support member (11) removably anchorable to a member of a working device, and surface working elements (13) in abrasive material, in the form of a plurality of side by side arranged plate-like working elements (13) having

side walls (13', 13'') and a front working surface (14) longitudinally extending between the side walls (13', 13''); each of the working elements (13) extends from one side face (11A) of the support member (11), and comprises a particulate abrasive filler material embedded into an elastomeric body.

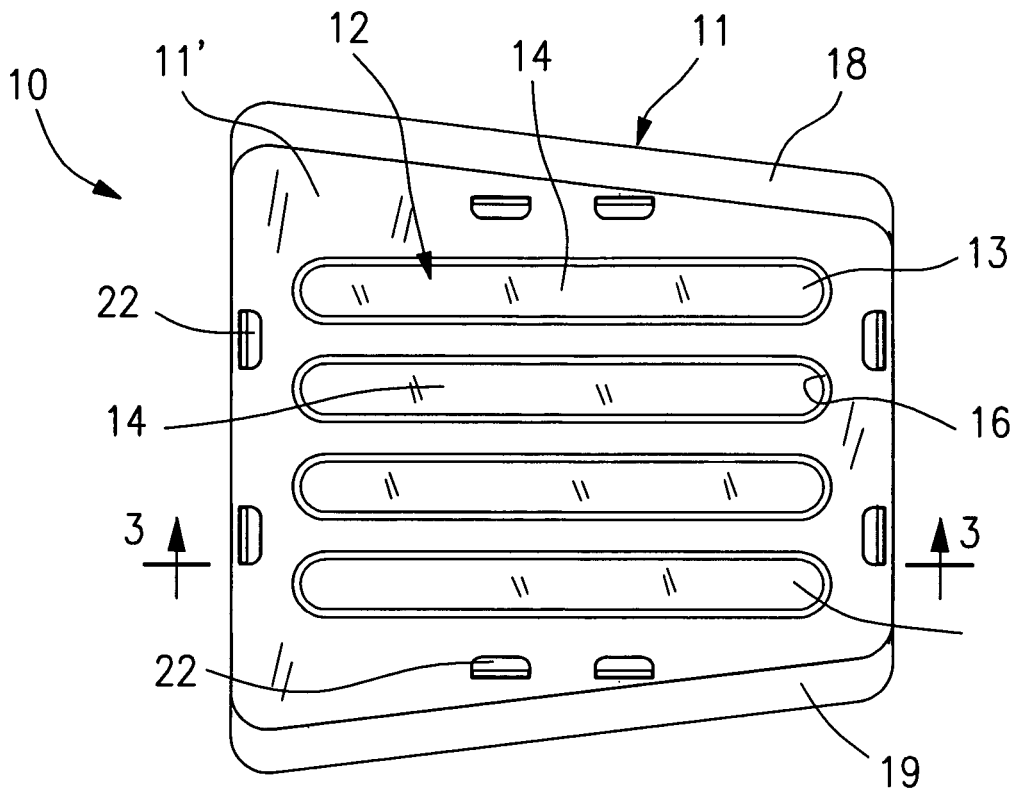

Fig. 1

Description

BACKGROUND OF THE INVENTION

[0001] This invention concerns an abrasive tool for surface treatment or working operations on marbles, stones, ceramic products in general, and the like, which can be used in particular for surface ageing, finishing, or roughing of the aforesaid materials.

STATE OF THE ART

[0002] In general, abrasive tools are widely known and used for surface working on marbles, stones, ceramic materials, grès, and the like; examples of such tools are described in FR-A-2 243 588, US-A-5,525,100, and EP-A-0 978 242, which are suitable to be used on conventional apparatuses for polishing and/or for surface treatment of the aforesaid materials.

[0003] In particular, FR-A-2 243 588 describes an abrasive tool of the aforementioned type, comprising a cylindrical body composed of a mass of binder material containing an agglomerated abrasive material in granules.

[0004] An abrasive tool of this kind however has the drawback that it could cause damage to the surfaces of the materials to be treated, in particular if the surface to be worked is not perfectly even, due to the compactness and stiffness of cylindrical abrasive body of the tool itself.

[0005] Moreover, the abrasive tool tends to wear out rapidly, due to the overstress it is subjected to when it encounters unevenness on the surfaces to be worked.

[0006] In order to limit the aforementioned drawbacks, in US-A-5,525,100 and EP-A-0 978 242 different solutions have been proposed for abrasive tools of the aforementioned kind, comprising in particular a support member which can be anchored to a movable member of a working device or apparatus, the support member being provided with a plurality of abrasive elements in the form of bristles or filaments composed of a resin-based material and a suitable abrasive material.

[0007] However, to a certain extent, these abrasive tools still have the aforementioned drawbacks, due to the fact that the resin-based material of the abrasive filaments has a high stiffness, therefore causing damage to the surface to be worked, in the form of so-called "burns", which can be observed in particular when the same surface is uneven or not perfectly smooth.

[0008] Moreover, the abrasive filaments of such tools are subjected over time to permanent deformation which is determined by the direction of operative movement given to the tool by the working device, giving rise to a rapid deterioration of the operative capacity of the same tool.

OBJECTS OF THE INVENTION

[0009] The main object of this invention is to provide

an abrasive tool for surface treatment or working operations on marbles, stones, ceramic products, and the like, which has high operative performances, and whereby it is possible to polish or treat surfaces of the abovementioned materials, without causing damage and/or "burns" on the treated surfaces.

[0010] A further object of this invention is to provide a tool of the aforementioned kind, which has constant performances over time, due to the absence of permanent deformation of the tool, and which tends to evenly wear, thereby guaranteeing a longer working life of the same tool.

BRIEF DESCRIPTION OF THE INVENTION

[0011] The above can be achieved by means of an abrasive tool for surface treatment or working operations on marbles, stones and the like, comprising:

- surface working elements in abrasive material;
- a support member for supporting said working elements, the support member being conformed to be removably anchored to a member of a working device, characterised in that said working elements in abrasive material comprise:
 - a plurality of side by side arranged plate-like working elements having side walls and a front working surface longitudinally extending between the said walls; each of the working elements extending from one side face of the support member, and comprising a particulate abrasive filler material embedded into an elastomeric body.

BRIEF DESCRIPTION OF THE DRAWINGS

[0012] These and further features according to this invention, will be more clearly evident from the following description with reference to the accompanying drawings, in which:

- Fig. 1 shows a front view of the abrasive tool for surface treatment of marbles, stones and the like, according to a first embodiment of the invention;
- Fig. 2 shows a rear view of the tool of Fig. 1;
- Fig. 3 shows a cross-sectional view of the tool of Fig. 1, along the line 3-3;
- Fig. 4 shows a cross-sectional view of the tool of Fig. 1, along the line 4-4 of Fig. 2;
- Fig. 5 shows a front view of the abrasive tool for surface treatment of marbles, stones and the like, according to a second embodiment of the invention;
- Fig. 6 shows a rear view of the tool of Fig. 5; and
- Figs. 7, 8 and 9 show an exploded side view of the tool of Fig. 5.

DETAILED DESCRIPTION OF THE INVENTION

[0013] The general features of this invention will be illustrated hereunder by means of several exemplificative embodiments.

[0014] Figures from 1 to 4 show an abrasive tool for surface treatment or working operations on marbles, stones, ceramic materials in general, and the like, according to a first embodiment of the invention.

[0015] The tool, indicated as a whole by the reference number 10, comprises a support member 11 conformed to be removably anchored to a movable member, not shown, of a conventional working device or apparatus for the surface treatment of the aforementioned materials.

[0016] The tool 10 also comprises a plurality of side by side arranged abrasive plate-like working elements 13, supported by the support member 11 and extending from one side face 11A of the same support member 11.

[0017] In this embodiment, as clearly illustrated in figures 3 and 4, the tool 10 in particular comprises a body 12 including said plurality of side by side arranged abrasive plate-like working elements 13.

[0018] Each working element 13 has side walls 13', 13" and a front working surface 14 longitudinally extending between the same side walls 13', 13".

[0019] The abrasive plate-like elements 13 comprise a particulate abrasive filler material embedded into an elastomeric body, as specified further on.

[0020] As illustrated in figures 3 and 4, the body 12 comprises at least one base body 12' from which extend the abrasive plate-like elements 13.

[0021] In this preferential embodiment, the support member 11 in turn comprises a first and a second half shell 11', 11" made of plastic material, engageable and couplable with each other, which define a seat 15 for housing and locking the base body 12'.

[0022] One of the half shells 11', 11", in this case the first half shell 11', is provided with a plurality of openings 16 for protrusion of the abrasive plate-like elements 13.

[0023] Preferentially, at least one of the half shells 11', 11" for housing the base body 12', in this case the second half shell 11", has internal surfaces provided with respective retaining ribbings 17 for retaining the same base body 12'.

[0024] The support member 11 comprises disengageable connecting means for removably anchoring to the movable member of the working device; in this preferential embodiment, such connecting means for anchoring the support member 11 comprise dovetail-shaped side walls 18, 19 on opposite sides of one of the half shells 11', 11", in this case the first half shell 11', the side walls 18, 19, being designed to engage with respective anchoring seats, not shown, on the movable member of the working device, and being strengthened by means of appropriate ribs 20.

[0025] The first and the second half shell 11', 11" engage with each other by means of suitable cou-

pling means, of the snap-on, restraining or other type, for example by means of coupling teeth 21 peripherally disposed on the second half shell 11", designed to engage in corresponding apertures 22 in the first half shell 11'.

[0026] Preferentially, the elastomeric body of the working elements 13 is obtained by vulcanisation, starting from an elastomeric material having a hardness comprised between 40 and 90 Shore degrees.

[0027] The particulate abrasive filler material embedded in the elastomeric body is comprised between 10% and 85% in weight out of the total weight, with a granulometry comprised between 16 to 1800, in relation to the use and the material which is to be worked.

[0028] For example, to carry out roughing and/or ageing operations, in relation to the materials to be worked, the abrasive plate-like elements 13 can comprise 10% to 50% in weight of particulate abrasive filler material out of the total weight, with a granulometry comprised between 16 to 60, or can comprise 50% to 70% in weight of particulate abrasive filler material out of the total weight, with a granulometry comprised between 60 to 500.

[0029] Conversely, to carry out finishing and/or polishing operations, also in relation to the materials to be worked, the abrasive plate-like elements 13 can for example comprise 70% to 80% in weight of particulate abrasive filler material out of the total weight, with a granulometry comprised between 500 to 1000, or can comprise over 80% in weight of particulate abrasive filler material out of the total weight, with a granulometry comprised between 1000 and 1800.

[0030] The tool 10 according to this first embodiment extends according to a longitudinal axis, and has abrasive plate-like elements 13 which extend parallel to the aforesaid longitudinal axis.

[0031] Alternatively, the abrasive plate-like elements 13 may for example extend parallel to one another in a crosswise or slanted direction with respect to the longitudinal axis of the tool 10, or parallel and offset in relation to one another, or also in radial directions on the tool, or in the form of arc-shaped elements, side by side arranged to one another.

[0032] However, other forms and dispositions of the abrasive plate-like elements according to the objects of the claims are not excluded.

[0033] Moreover, preferentially, the side walls 13', 13" of each abrasive plate-like elements 13 converges towards the front working surface 14.

[0034] A second embodiment of the tool according to this invention is shown in the figures from 5 to 9, in which the same reference numbers have been used to indicate similar or equivalent parts with respect to the previously described embodiment.

[0035] In particular, the tool 10 again comprises an support member 11, and a plurality of side by side arranged abrasive plate-like elements 13 comprising a particulate abrasive filler material embedded into an elasto-

meric body.

[0036] As illustrated in figures 7, 8 and 9, the support member 11 again comprises a first and a second half shell 11', 11" made of plastic material engageable and couplable with each other, which define a seat 15 for housing and locking a base body 12' from which extend the abrasive plate-like elements 13.

[0037] The tool 10 according to this embodiment differs from the previous embodiment in that the means for connecting the support member 11 to the member of the working device, are no longer defined by side walls of the same support member 11, but comprise a dovetail-shaped connecting member 23 which extends on an outer side of the second half shell 11", said connecting member 23 engaging with respective anchoring seats of member of the working device.

[0038] The tool 10 according to this embodiment also differs in that the abrasive plate-like elements 13 extend parallel to and offset in relation to one another in the direction of the longitudinal axis of the tool 10.

[0039] With regard to the characteristics of the elastomeric material, and the abrasive filler material, reference is made to the description of the first embodiment of the tool.

[0040] As an alternative to the abovementioned solution, whenever the abrasive plate-like elements are not provided with a base body, the support member according to this invention may be realised starting from plastic material moulded over an end portion of the abrasive plate-like elements opposite to the working surface of the same plate-like elements; conversely, whenever the abrasive plate-like elements are provided with base body, the support member may be realised starting from plastic material moulded over the same base body.

[0041] A tool according to this invention has high operative performances, especially due to the fact that the side by side arranged abrasive plate-like elements support one another during operation, since side walls 13', 13" contact and rest each others, and due to the fact that the plate-like elements have a continuous front working surface extending both in a longitudinal direction, and in a crosswise direction on the same tool.

[0042] Moreover, with the tool according to the invention it is possible to carry out surface treatment operations on the aforesaid materials, which are free from damage and/or "burns" on the treated surfaces, in that the elastomeric material in which the abrasive filler material is embedded is less rigid than the resin-based materials used for the conventional abrasive tools.

[0043] Thanks to the use of the elastomeric material, which is suitable for working several materials, when the plate-like elements of the tool according to the invention encounter any unevenness on the surface to be worked, they tend to flex in a controlled manner, thereby avoiding the formation of "burns" on the surface itself.

[0044] A further advantage of the tool according to the invention, is that it has constant performances over time, due to the fact that the plate-like elements made of elas-

tomeric material have an elastic "memory", and consequently there are no permanent deformations of the tool; hence, the abrasive plate-like elements tend to wear evenly, and at the same time ensure a longer working life of the same tool.

[0045] A still further advantage of the tool is that it produces very little sediment or mud during operation, therefore proving to be substantially ecological.

[0046] Lastly, with the tool according to this invention, owing to the possibility of separately moulding the support member made of two half shells, and the body comprising the abrasive plate-like working elements, it is possible to freely choose the material for the same support member, as well as to prepare tools having different operative features starting from a single common support member, by simply choosing an appropriate body having abrasive plate-like working elements, to be inserted between the half shells of the support member.

[0047] What has been described and shown with reference to the accompanying drawings has been given purely by way of example in order to illustrate the general features of the invention, as well as of several of its preferential embodiments; therefore other modifications and variations of the tool for surface treatment on marbles, stones, ceramic materials in general, and the like, are possible, without thereby deviating from the scope of the claims.

30 Claims

1. An abrasive tool (10) for surface treatment or working operations on marbles, stones and the like, comprising:

- surface working elements (13) in abrasive material;
- a support member (11) for supporting said working elements (13), the support member (11) being conformed to be removably anchored to a member of a working device, **characterised in that** said working elements (13) in abrasive material comprise:

- a plurality of side by side arranged plate-like working elements (13) having side walls (13', 13") and a front working surface (14) longitudinally extending between the said walls (13', 13"); each of the working elements (13) extending from one side face (11A) of the support member (11), and comprising a particulate abrasive filler material embedded into an elastomeric body.

2. Abrasive tool (10) according to claim 1, **characterised in that** the elastomeric body of said working elements (13) has a hardness comprised between 40 and 90 Shore degrees.

3. Abrasive tool (10) according to claim 2, **characterised in that** the particulate abrasive filler material embedded in said elastomeric body is comprised between 10% and 85% in weight out of the total weight.
4. Abrasive tool (10) according to claim 3, **characterised in that** the particulate abrasive filler material has a granulometry comprised between 16 to 1800.
5. Abrasive tool (10) according to claim 4, **characterised in that** said plate-like working elements (13) comprise 10% to 50% in weight of said particulate abrasive filler material out of the total weight, with a granulometry comprised between 16 to 60.
6. Abrasive tool (10) according to claim 4, **characterised in that** said plate-like working elements (13) comprise 50% to 70% in weight of said particulate abrasive filler material out of the total weight, with a granulometry comprised between 60 to 500.
7. Abrasive tool (10) according to claim 4, **characterised in that** said plate-like working elements (13) comprise 70% to 80% in weight of said particulate abrasive filler material out of the total weight, with a granulometry comprised between 500 to 1000.
8. Abrasive tool (10) according to claim 4, **characterised in that** said plate-like working elements (13) comprise over 80% in weight of said particulate abrasive filler material out of the total weight, with a granulometry comprised between 1000 and 1800.
9. Abrasive tool (10) according to claim 1, **characterised in that** said plate-like working elements (13) extend from at least one base body (12').
10. Abrasive tool (10) according to claim 9, **characterised in that** said support member (11) comprises a first and a second half shell (11', 11'') made of plastic material, engageable with one another, said first and second half shell (11', 11'') defining a seat (15) for housing and locking said base body (12'), and **in that** one of said first and second half shells (11') is provided with a plurality of openings (16) for protrusion of said abrasive plate-like elements (13).
11. Abrasive tool (10) according to claim 10, **characterised in that** said first and second half shell (11', 11'') comprise snap-on means (21, 22) for their reciprocal engagement.
12. Abrasive tool (10) according to claim 10, **characterised in that** said first and second half shell (11', 11'') comprise restraining means for their reciprocal engagement.
13. Abrasive tool (10) according to claim 10, **characterised in that** at least one of said first and second half shell (11', 11'') has internal surfaces provided with respective retaining ribbings (17) for retaining said base body (12').
14. Abrasive tool (10) according to claim 10, **characterised in that** said support member (11) comprises disengageable connecting means for removably anchoring to said member of the working device.
15. Abrasive tool (10) according to claim 14, **characterised in that** said disengageable means for anchoring the support member (11) comprise dovetail-shaped side walls (18, 19) on opposite sides of one (11') of said first and second half shell (11', 11''), said dovetail-shaped side walls (18, 19) engaging with respective anchoring seats of said member of the working device.
16. Abrasive tool (10) according to claim 14, **characterised in that** said connecting means for anchoring the support member (11) comprise a dovetail-shaped connecting member (23) which extends on an outer side of one (11'') of said first and second half shells (11', 11''), said connecting member (23) engaging with respective anchoring seats of said member of the working device.
17. Abrasive tool (10) according to claim 1, **characterised in that** said support member (11) is made of plastic material moulded over an end portion of said abrasive plate-like elements (13) opposite to the working surface (14) of the same plate-like elements (13).
18. Abrasive tool (10) according to claim 9, **characterised in that** said support member (11) is made of plastic material moulded over said base body (12') for said working elements (13).
19. Abrasive tool (10) according to claim 1, **characterised in that** said elastomeric body of the surface working elements (13) is obtained by vulcanisation.
20. Abrasive tool (10) according to claim 1, in which the tool (10) extends according to a longitudinal axis, **characterised in that** the abrasive plate-like elements (13) extend parallel to said longitudinal axis of the tool (10).
21. Abrasive tool (10) according to claim 1, in which the tool (10) extends according to a longitudinal axis, **characterised in that** the abrasive plate-like elements (13) extend parallel to one another in a cross-wise or slanted direction with respect to said longitudinal axis of the tool (10).
22. Abrasive tool (10) according to claim 1, **character-**

ised in that said abrasive plate-like elements (13) extend parallel to and offset in relation to one another from said support member (11).

23. Abrasive tool (10) according to claim 1, **characterised in that** said abrasive plate-like elements (13) extend in radial directions on said tool (10). 5
24. Abrasive tool (10) according to claim 1, **characterised in that** said abrasive plate-like elements (13) are in the form of arch-shaped elements, side by side arranged to one another. 10
25. Abrasive tool (10) according to claim 1, **characterised in that** the side walls (13', 13'') of each abrasive plate-like element (13) converges towards said front working surface (14). 15

20

25

30

35

40

45

50

55

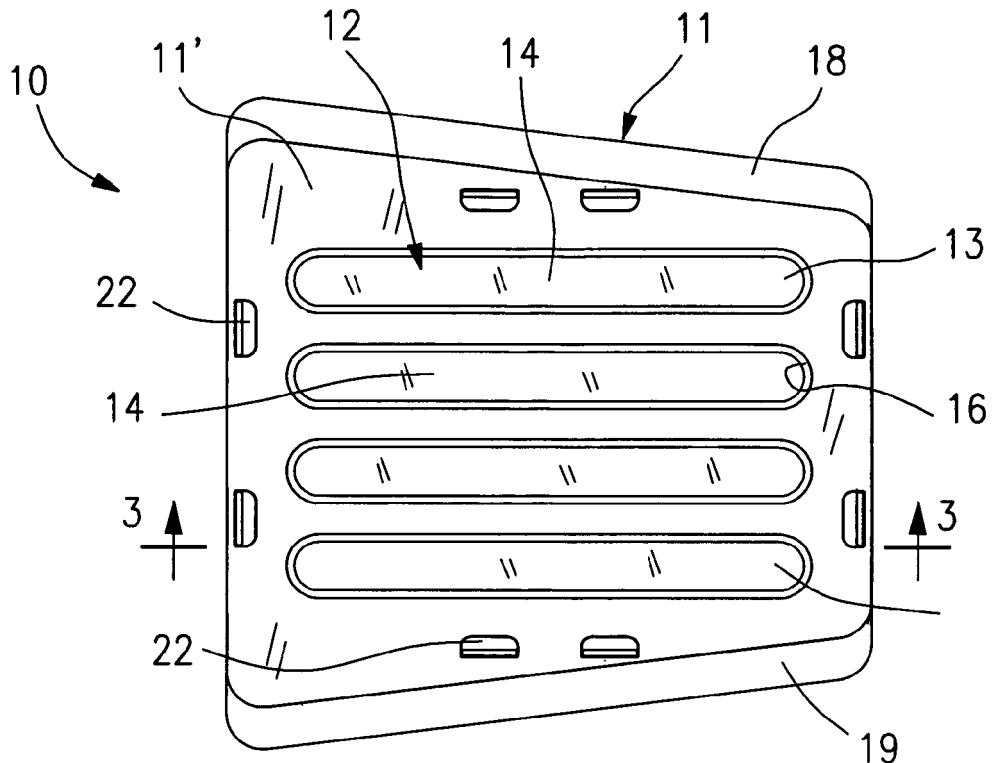

Fig. 1

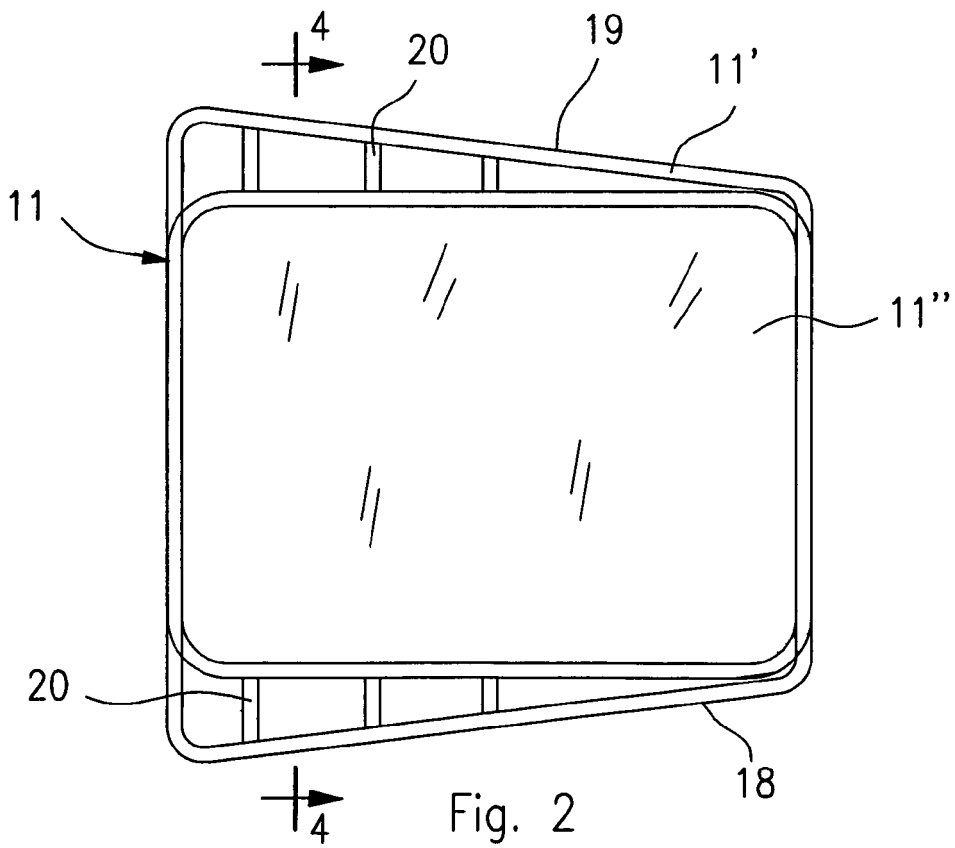

Fig. 2

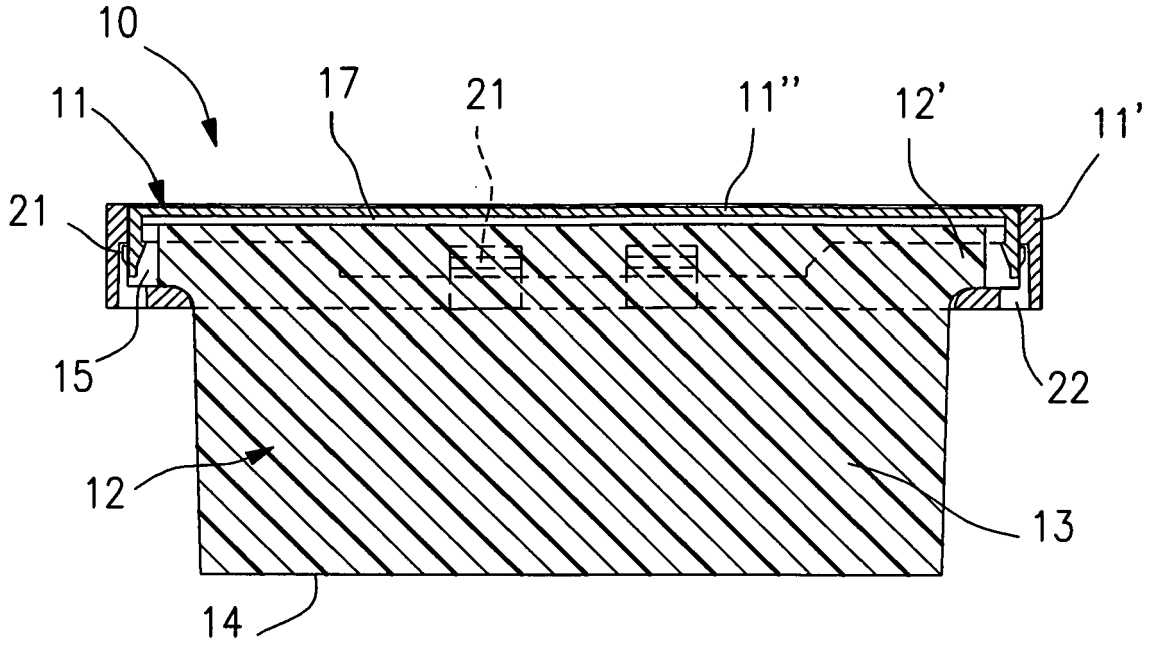

Fig. 3

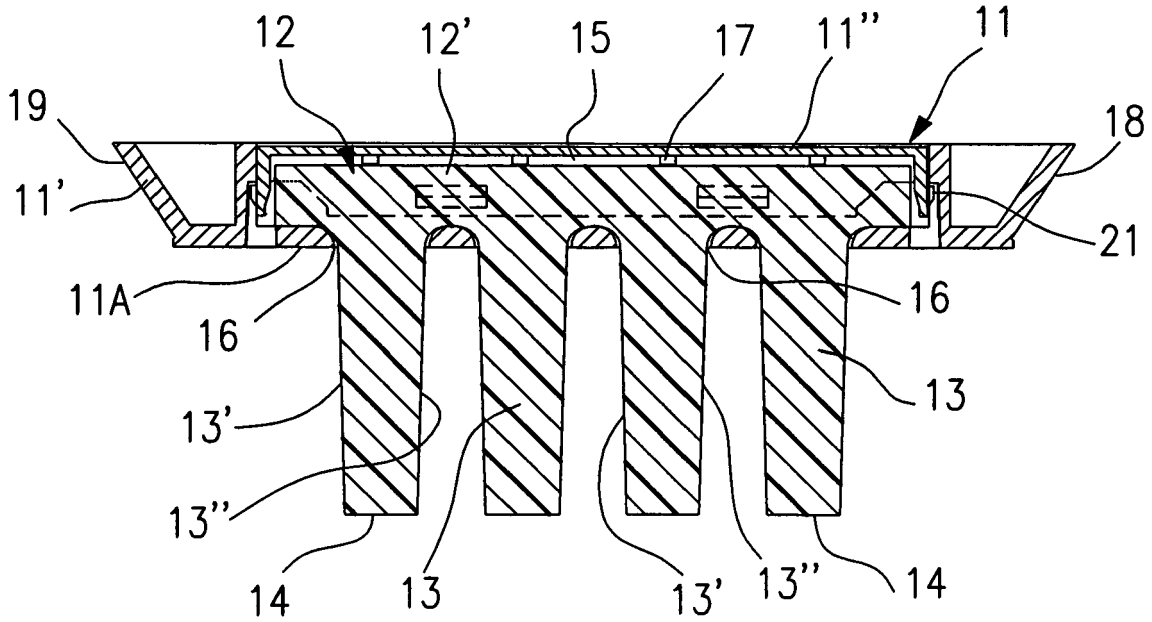

Fig. 4

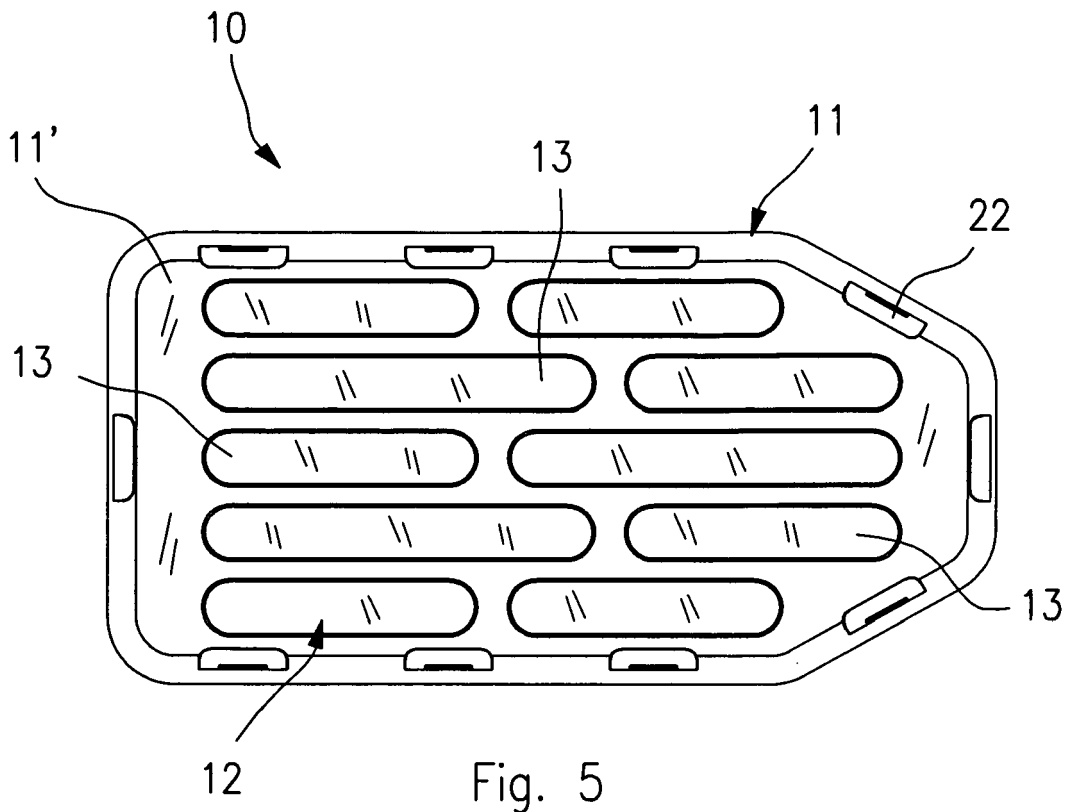

Fig. 5

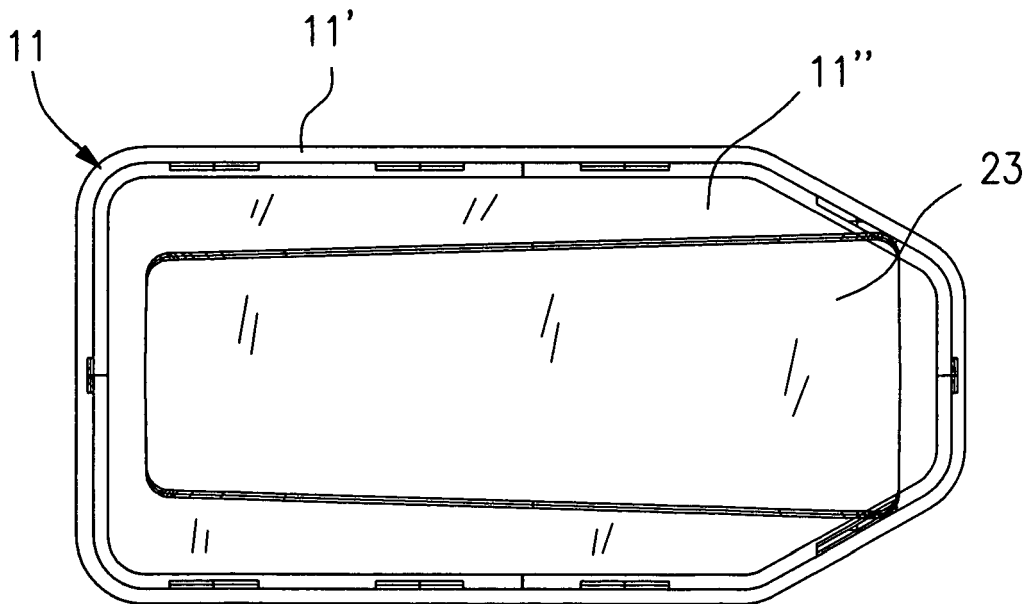
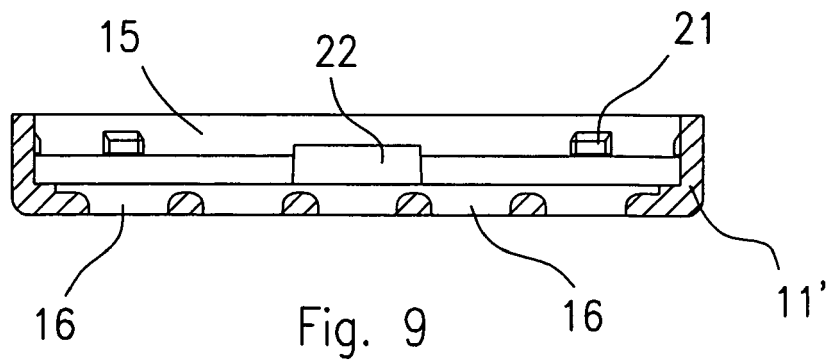
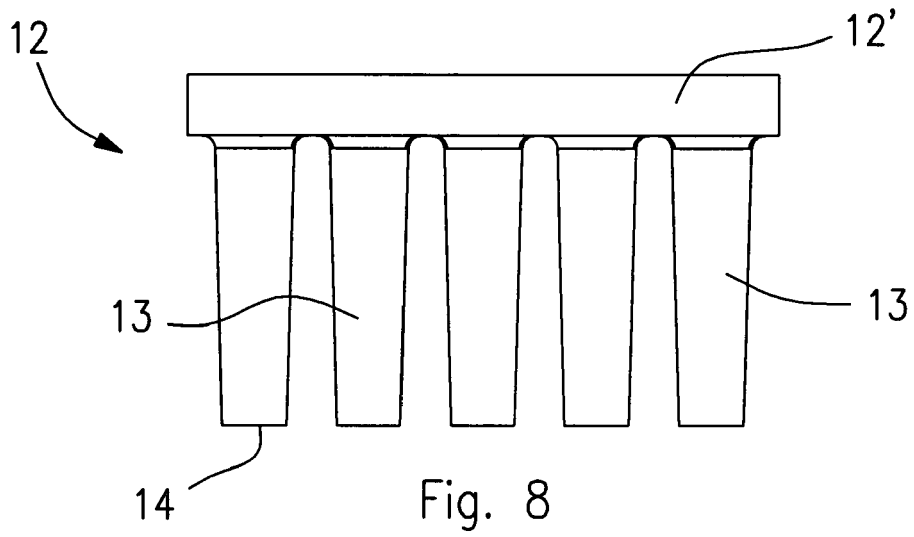
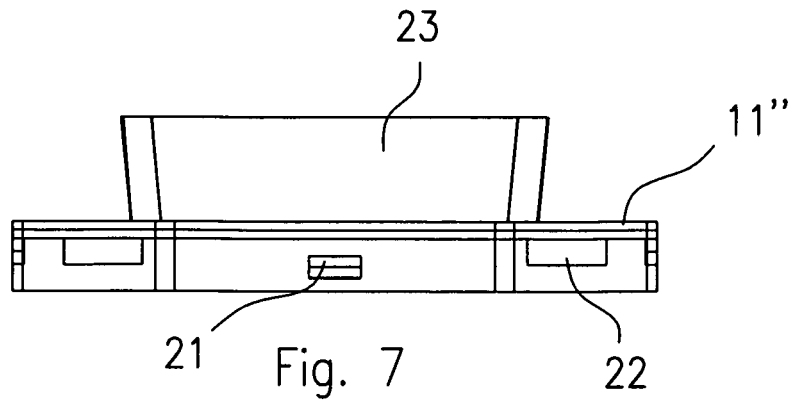

Fig. 6





DOCUMENTS CONSIDERED TO BE RELEVANT			
Category	Citation of document with indication, where appropriate, of relevant passages	Relevant to claim	CLASSIFICATION OF THE APPLICATION (IPC)
D,A	FR 2 243 588 A (GREMILLIET CLAUDE,FR) 4 April 1975 (1975-04-04) * the whole document * -----	1	INV. B24B/22
A	EP 1 036 523 A (MASTER SERVICE S.R.L; MASTER TRE S.R.L) 20 September 2000 (2000-09-20) * paragraphs [0002] - [0011]; figures 1-4 *	1	
A	US 2 757 491 A (GALEY WILLIAM F) 7 August 1956 (1956-08-07) * the whole document * -----	1	
			TECHNICAL FIELDS SEARCHED (IPC)
			B24B B24D
The present search report has been drawn up for all claims			
Place of search		Date of completion of the search	Examiner
Munich		30 August 2006	Koller, S
CATEGORY OF CITED DOCUMENTS			
X : particularly relevant if taken alone Y : particularly relevant if combined with another document of the same category A : technological background O : non-written disclosure P : intermediate document		T : theory or principle underlying the invention E : earlier patent document, but published on, or after the filing date D : document cited in the application L : document cited for other reasons & : member of the same patent family, corresponding document	

1
EPO FORM 1505 03.82 (P04C01)

**ANNEX TO THE EUROPEAN SEARCH REPORT
ON EUROPEAN PATENT APPLICATION NO.**

EP 06 00 9404

This annex lists the patent family members relating to the patent documents cited in the above-mentioned European search report. The members are as contained in the European Patent Office EDP file on
The European Patent Office is in no way liable for these particulars which are merely given for the purpose of information.

30-08-2006

Patent document cited in search report		Publication date	Patent family member(s)	Publication date
FR 2243588	A	04-04-1975	NONE	

EP 1036523	A	20-09-2000	AT 239404 T	15-05-2003
			DE 60002517 D1	12-06-2003
			ES 2197065 T3	01-01-2004
			IT MI990087 U1	16-08-2000

US 2757491	A	07-08-1956	NONE	

EPO FORM P0469

For more details about this annex : see Official Journal of the European Patent Office, No. 12/82

REFERENCES CITED IN THE DESCRIPTION

This list of references cited by the applicant is for the reader's convenience only. It does not form part of the European patent document. Even though great care has been taken in compiling the references, errors or omissions cannot be excluded and the EPO disclaims all liability in this regard.

Patent documents cited in the description

- FR 2243588 A [0002] [0003]
- US 5525100 A [0002] [0006]
- EP 0978242 A [0002] [0006]