

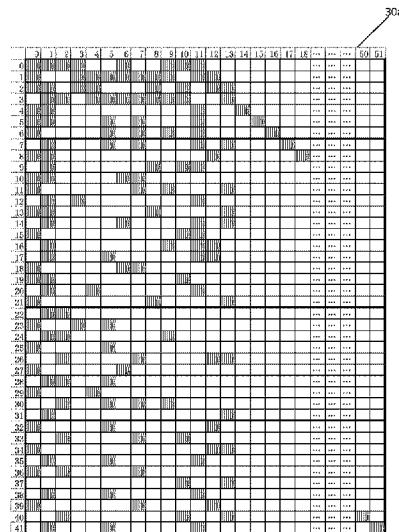

(86) Date de dépôt PCT/PCT Filing Date: 2017/07/13
 (87) Date publication PCT/PCT Publication Date: 2018/12/20
 (45) Date de délivrance/Issue Date: 2022/10/04
 (85) Entrée phase nationale/National Entry: 2019/09/03
 (86) N° demande PCT/PCT Application No.: CN 2017/092878
 (87) N° publication PCT/PCT Publication No.: 2018/227681
 (30) Priorités/Priorities: 2017/06/15 (CN201710454030.3);
 2017/06/27 (CN201710503056.2)

(51) Cl.Int./Int.Cl. *H03M 13/11* (2006.01)
 (72) Inventeurs/Inventors:
 JIN, JIE, CN;
 TONG, WEN, CN;
 WANG, JUN, CN;
 PETYUSHKO, ALEXANDER, CN;
 MAZURENKO, IVAN LEONIDOVICH, CN;
 ZHANG, CHAOLONG, CN
 (73) Propriétaire/Owner:
 HUAWEI TECHNOLOGIES CO., LTD., CN
 (74) Agent: GOWLING WLG (CANADA) LLP

(54) Titre : PROCÉDE DE TRAITEMENT D'INFORMATIONS ET APPAREIL DE COMMUNICATION
 (54) Title: INFORMATION PROCESSING METHOD AND COMMUNICATION APPARATUS



(57) **Abrégé/Abstract:**

This application discloses an encoding method, an apparatus, a communication device, and a communication system. The method includes: encoding an input bit sequence by using a low density parity check LDPC matrix, where the LDPC matrix is obtained based on a base graph, and the base graph includes submatrices A, B, C, D, and E, where the submatrix A is a matrix including m_A rows and n_A columns, m_A and n_A are positive integers, $4 \leq m_A \leq 7$, and $n_A = 10$; the submatrix B is a matrix including m_A rows and m_A columns, and the submatrix B includes a column whose weight is 3 and a submatrix B' having a double diagonal structure; the submatrix D includes m_D rows in a matrix F, the matrix F is a matrix including m_F rows and $(m_A + n_A)$ columns, m_D and m_F are positive integers, $0 \leq m_D \leq m_F$, and $35 \leq m_F \leq 38$; the submatrix C is an all zero matrix including m_A rows and m_D columns; and the submatrix E is an identity matrix including m_D rows and m_D columns. The encoding method, the apparatus, the communication device, and the communication system in this application can support a requirement for encoding information bit sequences of various lengths.

ABSTRACT

This application discloses an encoding method, an apparatus, a communication device, and a communication system. The method includes: encoding an input bit sequence by using a low density parity check LDPC matrix, where the LDPC matrix is obtained based on a base graph, and the base graph includes submatrices A, B, C, D, and E, where the submatrix A is a matrix including m_A rows and n_A columns, m_A and n_A are positive integers, $4 \leq m_A \leq 7$, and $n_A = 10$; the submatrix B is a matrix including m_A rows and m_A columns, and the submatrix B includes a column whose weight is 3 and a submatrix B' having a double diagonal structure; the submatrix D includes m_D rows in a matrix F, the matrix F is a matrix including m_F rows and $(m_A + n_A)$ columns, m_D and m_F are positive integers, $0 \leq m_D \leq m_F$, and $35 \leq m_F \leq 38$; the submatrix C is an all zero matrix including m_A rows and m_D columns; and the submatrix E is an identity matrix including m_D rows and m_D columns. The encoding method, the apparatus, the communication device, and the communication system in this application can support a requirement for encoding information bit sequences of various lengths.

INFORMATION PROCESSING METHOD AND COMMUNICATION APPARATUS

TECHNICAL FIELD

[0001] Embodiments of the present application relate to the communication field, and in particular, to an information processing method and a communication apparatus.

BACKGROUND

[0002] Low density parity check (low density parity check, LDPC) code is a type of linear block code including a sparse check matrix, and is characterized by a flexible structure and low decoding complexity. Because decoding the LDPC code uses a partially parallel iterative decoding algorithm, the LDPC code has a higher throughput than a conventional turbo code. The LDPC code may be used as an error-correcting code in a communication system, so as to increase channel transmission reliability and power utilization. LDPC code may further be widely applied to space communication, fiber optic communication, a personal communication system, an ADSL, a magnetic recording device, and the like. LDPC code scheme has been currently considered as one of channel coding schemes in the fifth generation mobile communication systems.

[0003] In practical applications, LDPC matrices characterized by different special structures may be used. An LDPC matrix H , having a special structure, may be obtained by expanding an LDPC base matrix having a quasi cyclic (quasi cycle, QC) structure.

[0004] Generally, lengths of to-be-encoded information bit sequences vary from tens to hundreds of bits, and code rates required by a communication system are also flexibly variable. How to support encoding on information bit sequences of various lengths, to satisfy code rate requirements of a system becomes a problem that needs to be resolved.

SUMMARY

[0005] Embodiments of the present application provide an information processing method, a communication apparatus, and a communication system, to support encoding and decoding of information bit sequences of various lengths and meet flexible code length and code rate requirements of the communication system.

[0006] According to a first aspect, an encoding method and an encoder are provided. The encoder encodes an input sequence by using a low-density parity-check LDPC matrix.

[0007] According to a second aspect, a decoding method and a decoder are provided. The decoder decodes an input sequence by using a low-density parity-check LDPC matrix.

5 [0008] In a first implementation of the first aspect or the second aspect, the LDPC matrix is obtained based on a base graph, and the base graph includes submatrix A, submatrix B, submatrix C, submatrix D, and submatrix E, where

the submatrix A is a matrix including m_A rows and n_A columns, m_A and n_A are positive integers, $4 \leq m_A \leq 7$, and $n_A = 10$;

10 the submatrix B is a matrix including m_A rows and m_A columns, and the submatrix B includes a column whose weight is 3 and a submatrix B' having a bi-diagonal structure;

the submatrix D includes m_D rows in a matrix F, the matrix F is a matrix including m_F rows and $(m_A + n_A)$ columns, m_D and m_F are positive integers, $0 \leq m_D \leq m_F$, and $35 \leq m_F \leq 38$;

the submatrix C is an all zero matrix including m_A rows and m_D columns; and

15 the submatrix E is an identity matrix including m_D rows and m_D columns.

[0009] Based on the foregoing implementation, in a possible implementation, any two adjacent rows in the last 10 rows in the base graph are mutually orthogonal.

[0010] Based on the foregoing implementations, in a possible implementation, the last 10 rows in the base graph include at least five groups, each of the at least five groups includes at least two
20 rows, and the at least two rows are mutually orthogonal.

[0011] Based on any of the foregoing implementations, in a possible implementation, in the matrix F, weights of nine rows are 3, and a weight of one row is 2.

[0012] In a design, in the matrix F, a weight of one column is 16, a weight of one column is 18, a weight of one column is 11, weights of two columns are 10, a weight of one column is 9, a
25 weight of one column is 8, a weight of one column is 7, a weight of one column is 6, weights of two columns are 4, a weight of one column is 3, and weights of two columns are 2.

[0013] Based on the first implementation, in another possible implementation, a row count of rows having an orthogonal structure in the matrix F is greater than or equal to 10, and in the matrix
30 F, a weight of one column is 16, a weight of one column is 18, a weight of one column is 11, weights of two columns are 10, a weight of one column is 9, a weight of one column is 8, a weight of one column is 7, a weight of one column is 6, weights of two columns are 4, a weight of one column is 3, and weights of two columns are 2.

[0014] In another design, in the matrix F, weights of nine rows are 3, and a weight of one row

is 2.

[0015] In another design, the matrix F includes at least 10 rows, and any two adjacent rows in the at least 10 rows are mutually orthogonal.

[0016] In another design, the matrix F includes at least five groups, each of the at least five groups includes at least two rows, and the at least two rows are mutually orthogonal. Optionally, the at least two rows may be consecutive rows. For example, the at least 10 rows may be the last 10 rows in a base graph 30a.

[0017] In any of the foregoing implementations, if $m_A > 4$, weights of columns other than m_A columns in the matrix F is 0.

[0018] For example, 10 rows having the orthogonal structure in the matrix F may include, for example, rows or columns of a matrix block including row 25 to row 34 and column 0 to column 13 in the base graph 30a; or 10 rows having the orthogonal structure in the matrix F may include, for example, rows or columns of a matrix block including row 25 to row 34 and column 0 to column 16 in the base graph 30a. In the matrix F, rows may be switched with each other, and columns may also be switched with each other.

[0019] Based on the foregoing implementations, a base matrix of the base graph 30a may be, for example, any one of base matrices 30b-1, 30b-2, 30b-3, 30b-4, 30b-5, 30b-6, 30b-7, and 30b-8, or a matrix obtained by performing row/column permutation on any one of base matrices 30b-1, 30b-2, 30b-3, 30b-4, 30b-5, 30b-6, 30b-7, and 30b-8.

[0020] Based on the foregoing implementations, a shift matrix of the matrix F may be a matrix including row 7 to row 41 and column 0 to column 16 in any matrix of 30b-1 to 30b-8, or a matrix obtained by performing row/column permutation on the matrix including row 7 to row 41 and column 0 to column 16 in any matrix of 30b-1 to 30b-8; or a shift matrix of the matrix F may include a matrix including row 4 to row 41 and column 0 to column 14 in any matrix of 30b-1 to 30b-8, or a matrix obtained by performing row/column permutation on the matrix including row 4 to row 41 and column 0 to column 14 in any matrix of 30b-1 to 30b-8.

[0021] To support different code block lengths, the LDPC code needs different lifting factors Z. Based on the foregoing implementations, in a possible implementation, based on the different lifting factors Z, base matrices corresponding to the different lifting factors Z are used. For example, $Z = a \times 2^j$, where $a \in \{2, 3, 5, 7, 9, 11, 13, 15\}$.

[0022] If the lifting factor is one satisfying $Z = 2 \times 2^j$, where $j = 0, 1, 2, 3, 4, 5, 6, 7$, the shift matrix of the matrix F may be the matrix including row 7 to row 41 and column 0 to column 16 in 30b-1, or the matrix obtained by performing the row/column permutation on the matrix including row 7 to row 41 and column 0 to column 16 in 30b-1; or the shift matrix of the matrix

F may be the matrix including row 4 to row 41 and column 0 to column 14 in 30b-1, or the matrix obtained by performing row/column permutation on the matrix including row 4 to row 41 and column 0 to column 14 in 30b-1. Correspondingly, the base matrix of the base graph 30a may be the matrix shown in 30b-1, or the matrix obtained by performing row/column permutation on the matrix shown in 30b-1.

5
[0023] If the lifting factor is one satisfying $Z = 3 \times 2^j$, where $j = 0, 1, 2, 3, 4, 5, 6, 7$, the shift matrix of the matrix F may be the matrix including row 7 to row 41 and column 0 to column 16 in 30b-2, or the matrix obtained by performing row/column permutation on the matrix including row 7 to row 41 and column 0 to column 16 in 30b-2; or the shift matrix of the matrix F may be the matrix including row 4 to row 41 and column 0 to column 14 in 30b-2, or the matrix obtained by performing row/column permutation on the matrix including row 4 to row 41 and column 0 to column 14 in 30b-2. Correspondingly, the base matrix of the base graph 30a may be the matrix shown in 30b-2, or the matrix obtained by performing row/column permutation on the matrix shown in 30b-2.

10
[0024] If the lifting factor is one satisfying $Z = 5 \times 2^j$, where $j = 0, 1, 2, 3, 4, 5, 6$, the shift matrix of the matrix F may be the matrix including row 7 to row 41 and column 0 to column 16 in 30b-3, or the matrix obtained by performing row/column permutation on the matrix including row 7 to row 41 and column 0 to column 16 in 30b-3; or the shift matrix of the matrix F may be the matrix including row 4 to row 41 and column 0 to column 14 in 30b-3, or the matrix obtained by performing row/column permutation on the matrix including row 4 to row 41 and column 0 to column 14 in 30b-3. Correspondingly, the base matrix of the base graph 30a may be the matrix shown in 30b-3, or the matrix obtained by performing row/column permutation on the matrix shown in 30b-3.

15
[0025] If the lifting factor satisfying one in $Z = 7 \times 2^j$, where $j = 0, 1, 2, 3, 4, 5$, the shift matrix of the matrix F may be the matrix including row 7 to row 41 and column 0 to column 16 in 30b-4, or the matrix obtained by performing row/column permutation on the matrix including row 7 to row 41 and column 0 to column 16 in 30b-4; or the shift matrix of the matrix F may be the matrix including row 4 to row 41 and column 0 to column 14 in 30b-4, or the matrix obtained by performing row/column permutation on the matrix including row 4 to row 41 and column 0 to column 14 in 30b-4. Correspondingly, the base matrix of the base graph 30a may be the matrix shown in 30b-4, or the matrix obtained by performing row/column permutation on the matrix shown in 30b-4.

20
[0026] If the lifting factor is one satisfying $Z = 9 \times 2^j$, where $j = 0, 1, 2, 3, 4, 5$, the shift matrix of the matrix F may be the matrix including row 7 to row 41 and column 0 to column 16 in 30b-

5, or the matrix obtained by performing row/column permutation on the matrix including row 7 to row 41 and column 0 to column 16 in 30b-5; or the shift matrix of the matrix F may be the matrix including row 4 to row 41 and column 0 to column 14 in 30b-5, or the matrix obtained by performing row/column permutation on the matrix including row 4 to row 41 and column 0 to column 14 in 30b-5. Correspondingly, the base matrix of the base graph 30a may be the matrix shown in 30b-5, or the matrix obtained by performing row/column permutation on the matrix shown in 30b-5.

[0027] If the lifting factor is one satisfying $Z = 11 \times 2^j$, where $j = 0, 1, 2, 3, 4, 5$, the shift matrix of the matrix F may be the matrix including row 7 to row 41 and column 0 to column 16 in 30b-6, or the matrix obtained by performing row/column permutation on the matrix including row 7 to row 41 and column 0 to column 16 in 30b-6; or the shift matrix of the matrix F may be the matrix including row 4 to row 41 and column 0 to column 14 in 30b-6, or the matrix obtained by performing row/column permutation on the matrix including row 4 to row 41 and column 0 to column 14 in 30b-6. Correspondingly, the base matrix of the base graph 30a may be the matrix shown in 30b-6, or the matrix obtained by performing row/column permutation on the matrix shown in 30b-6.

[0028] If the lifting factor is one satisfying $Z = 13 \times 2^j$, where $j = 0, 1, 2, 3, 4$, the shift matrix of the matrix F may be the matrix including row 7 to row 41 and column 0 to column 16 in 30b-7, or the matrix obtained by performing row/column permutation on the matrix including row 7 to row 41 and column 0 to column 16 in 30b-7; or the shift matrix of the matrix F may be the matrix including row 4 to row 41 and column 0 to column 14 in 30b-7, or the matrix obtained by performing row/column permutation on the matrix including row 4 to row 41 and column 0 to column 14 in 30b-7. Correspondingly, the base matrix of the base graph 30a may be the matrix shown in 30b-7, or the matrix obtained by performing row/column permutation on the matrix shown in 30b-7.

[0029] If the lifting factor is one satisfying $Z = 15 \times 2^j$, where $j = 0, 1, 2, 3, 4$, the shift matrix of the matrix F may be the matrix including row 7 to row 41 and column 0 to column 16 in 30b-8, or the matrix obtained by performing row/column permutation on the matrix including row 7 to row 41 and column 0 to column 16 in 30b-8; or the shift matrix of the matrix F may be the matrix including row 4 to row 41 and column 0 to column 14 in 30b-8, or the matrix obtained by performing row/column permutation on the matrix including row 4 to row 41 and column 0 to column 14 in 30b-8. Correspondingly, the base matrix of the base graph 30a may be the matrix shown in 30b-8, or the matrix obtained by performing row/column permutation on the matrix shown in 30b-8.

[0030] Further, optionally, based on the foregoing implementations, for the lifting factors Z, an element $P_{i,j}=f(V_{i,j},Z)$ in row i and column j in the base matrix of Z may further be obtained according to the base matrices of the foregoing sets, where $V_{i,j}$ is an element in row i and column j in the base matrix of the set to which the lifting factor Z belongs.

5 [0031] For example,

$$P_{i,j} = \begin{cases} -1 & V_{i,j} = -1 \\ \text{mod}(V_{i,j}, Z) & V_{i,j} \geq 0 \end{cases}$$

[0032] In another possible implementation, the base graph or the base matrix may further include at least one column corresponding to built-in puncture bits.

10 [0033] In the foregoing implementations, the base graph and the base matrix of the LDPC matrix may satisfy performance requirements of code blocks whose block length are 20 to 2560 bits.

[0034] Based on the foregoing aspects or any possible implementation of the aspects, in another possible implementation, the method further includes: determining the lifting factor Z. For example, a value of the lifting factor Z is determined according to a length K of the input sequence. For example, if the length of the input sequence is K, a minimum value satisfying $10 \times Z \geq K$ may be determined from a plurality of lifting factors defined in a system.

[0035] Optionally, the LDPC matrix may be obtained based on the base matrix corresponding to Z, or based on a shift matrix corresponding to Z.

20 [0036] For a communication device at a transmit end, the encoding an input sequence by using an LDPC matrix includes:

encoding the input sequence by using an LDPC matrix corresponding to the lifting factor Z; or encoding the input sequence by using a matrix, wherein the matrix is obtained by performing row/column permutation on an LDPC matrix corresponding to the lifting factor Z. In this application, the row/column permutation refers to row permutation, column permutation, or row permutation and column permutation.

25 [0037] For a communication device at a receive end, the decoding an input sequence by using an LDPC matrix includes:

30 decoding the input sequence by using an LDPC matrix corresponding to the lifting factor Z; or performing row/column permutation on an LDPC matrix corresponding to the lifting factor Z, and decoding the input sequence by using a matrix obtained by performing row/column permutation on an LDPC matrix corresponding to the lifting factor Z. In this application, the row/column permutation refers to row permutation, column permutation, or row permutation and column permutation.

[0038] In a possible implementation, the LDPC matrix may be stored in the memory, and the input sequence is encoded by using the LDPC matrix; or an LDPC matrix that may be used for encoding is obtained by performing permutation (row/column permutation) or lifting based on the LDPC matrix.

5 [0039] In another possible implementation, parameters may be stored in the memory, and an LDPC matrix used for encoding or decoding may be obtained according to the parameters, so that the input sequence may be encoded or decoded based on the LDPC matrix. The parameters include at least one of the following: a base graph, a base matrix, a permuted matrix obtained by performing row/column permutation on the base graph or the base matrix, a lifted matrix based
10 on the base graph or the base matrix, a shift value of a non-zero-element in the base matrix, or any parameter related to the obtaining the LDPC matrix.

[0040] In still another possible implementation, the base matrix of the LDPC matrix may be stored in a memory.

[0041] In still another possible implementation, the base graph of the LDPC matrix is stored
15 in a memory, and shift values of non-zero-elements in the base matrix of the LDPC matrix may be stored in the memory.

[0042] Based on the foregoing possible implementations, in a possible design, at least one of a base graph and a base matrix that are used for LDPC encoding or decoding is obtained by performing row permutation, column permutation, or row permutation and column permutation
20 on at least one of the base graph and the base matrices of the LDPC matrix.

[0043] According to a third aspect, a communication apparatus is provided. The communication apparatus may include corresponding modules configured to perform the foregoing method designs. The modules may be software and/or hardware.

[0044] In a possible design, the communication apparatus provided in the third aspect includes
25 a processor and a transceiver component, and the processor and the transceiver component may be configured to implement functions in the foregoing encoding or decoding method. In this design, if the communication apparatus is a terminal, a base station, or another network device, the transceiver component of the communication apparatus may be a transceiver. If the communication apparatus is a baseband chip or a baseband processing board, the transceiver
30 component of the communication apparatus may be an input/output circuit of the baseband chip or the baseband processing board, and is configured to receive/send an input/output signal. The communication apparatus may optionally include a memory, configured to store data and/or an instruction.

[0045] In an implementation, the processor may include the encoder according to the

foregoing first aspect and a determining unit. The determining unit is configured to determine a lifting factor Z required for encoding the input sequence. The encoder is configured to encode the input sequence by using the LDPC matrix corresponding to the lifting factor Z .

5 [0046] In another implementation, the processor may include the decoder according to the foregoing second aspect and an obtaining unit. The obtaining unit is configured to obtain soft values of the LDPC code and a lifting factor Z . The decoder is configured to decode the soft values of the LDPC code based on a base matrix H_B corresponding to the lifting factor Z , to obtain an information bit sequence.

10 [0047] According to a fourth aspect, a communication apparatus is provided. The communication apparatus includes one or more processors.

[0048] In a possible design, the one or more processors may implement a function of the encoder in the first aspect. In another possible design, the encoder in the first aspect may be a part of the processor. In addition to the function of the encoder in the first aspect, the processor may further implement other functions.

15 [0049] In a possible design, the one or more processors may implement a function of the decoder in the second aspect. In another possible design, the decoder in the second aspect may be a part of the processor.

[0050] Optionally, the communication apparatus may further include a transceiver and an antenna.

20 [0051] Optionally, the communication apparatus may further include a component configured to produce a transport block CRC, a component used for code block segmentation and CRC attachment, an interleaver used for interleaving, a modulator used for modulation processing, or the like.

25 [0052] Optionally, the communication apparatus may further include a demodulator used for a demodulation operation, a deinterleaver used for deinterleaving, a component used for de-rate matching, or the like. Functions of the components may be implemented by using the one or more processors.

[0053] In a possible design, functions of the components may be implemented by using the one or more processors.

30 BRIEF DESCRIPTION OF DRAWINGS

[0054] FIG. 1 is a schematic diagram of a base graph and a base matrix of an LDPC code, and circular permutation matrices of the base matrix in an LDPC code scheme;

[0055] FIG. 2 is a schematic structural diagram of a base graph of an LDPC code;

[0056] FIG. 3a is a schematic diagram of a base graph of an LDPC code according to an embodiment of the present application;

[0057] FIG. 3b-1 to FIG. 3b-8 show schematic diagrams of base matrices of the base graph shown in FIG. 3a;

5 [0058] FIG. 4 is a schematic performance diagram according to an embodiment of the present application;

[0059] FIG. 5 is a schematic structural diagram of an information processing apparatus according to an embodiment of the present application; and

[0060] FIG. 6 is a schematic diagram of a communication system according to an embodiment
10 of the present application.

DESCRIPTION OF EMBODIMENTS

[0061] To facilitate understanding, some terms in this application are described below.

[0062] In this application, terms "network" and "system" are usually interchanged, and terms "apparatus" and "device" are also usually interchanged. However, a person skilled in the art may
15 understand their meanings. A "communication apparatus" may be a chip (such as a baseband chip, or a digital signal processing chip, or a general-purpose chip), a terminal, a base station, or another network device. The terminal is a device having a communication function. The terminal may include a handheld device, an in-vehicle device, a wearable device, and a computing device that
20 have a wireless communication function, or another processing device connected to a wireless modem, or the like. The terminal may have different names in different networks, for example, user equipment, a mobile station, a user unit, a station, a cellular phone, a personal digital assistant, a wireless modem, a wireless communication device, a handheld device, a laptop computer, a cordless telephone set, and a wireless local loop station. For ease of description, in this application, the devices are referred to as the terminal for short. The base station (base station, BS), also
25 referred to as a base station device, is a device deployed in a radio access network to provide a wireless communication function. In different radio access systems, names of the base station may be different. For example, a base station in a Universal Mobile Telecommunication System (Universal Mobile Telecommunication System, UMTS) network is referred to as a node B (NodeB), a base station in an LTE network is referred to as an evolved node B (evolved NodeB,
30 eNB, or eNodeB), a base station in a new radio (new radio, NR) network is referred to as a transmission reception point (transmission reception point, TRP) or a next-generation node B (generation nodeB, gNB), or a base station in various other networks may also be referred to as other names. The present application is not limited thereto.

[0063] The following describes the technical solutions in the embodiments of the present application with reference to the accompanying drawings in the embodiments of the present application.

[0064] Usually, an LDPC code can be defined by using a parity check matrix H. The parity check matrix H for the LDPC code may be obtained by using a base graph (base graph) and shift (shift) values. Usually, the base graph may include $m \times n$ matrix elements (entry). The base graph may be represented by using a matrix including m rows and n columns. Value of each matrix element is either 0 or 1. An element whose value is 0 is also referred to as a zero-element sometimes, which may be replaced with an all zero matrix (zero matrix) of size $Z \times Z$. An element whose value is 1 is also referred to as a non-zero-element sometimes, which may be replaced with a circular permutation matrix (circular permutation matrix) of size $Z \times Z$. That is, each matrix element represents an all zero matrix or a circular permutation matrix. FIG. 1 shows an example 10a of a base graph of an LDPC code in which $m=4$ and $n=20$ and that has a QC structure. It should be noted that in this specification, row indexes and column indexes of a base graph and a matrix are all numbered starting from 0. This is only for ease of understanding. It may be understood that the row indexes and the column indexes may alternatively be numbered starting from 1, and corresponding row indexes and column indexes are increased by 1 based on the row indexes and the column indexes shown in this specification.

[0065] If a value of an element in row i and column j in the base graph is 1, it is assigned a shift value $P_{i,j}$. $P_{i,j}$ is an integer greater than or equal to 0, it indicates that the element of 1 (a non-zero-element) in row i and column j may be replaced with a circular permutation matrix of size $Z \times Z$ corresponding to $P_{i,j}$. The circular permutation matrix may be obtained by circularly shifting an identity matrix of size $Z \times Z$ to the right for $P_{i,j}$ times. It may be learned that in the base graph, each element whose value is 0 is replaced with an all zero matrix of size $Z \times Z$, and each element whose value is 1 is replaced with a circular permutation matrix of size $Z \times Z$ corresponding to a shift value of the element, so that the parity check matrix of the LDPC code can be obtained. The base graph may be used to indicate positions of shift values, and each non-zero-element in the base graph corresponds to a shift value. Z is a positive integer, may also be referred to as a lifting (lifting) factor, and may also be referred to as a lifting size, a lifting factor, or the like sometimes. Z may be determined according to a code block size that are supported by a system and size of information data. It may be learned that the parity check matrix H has a size of $(m \times Z) \times (n \times Z)$. For example, if the lifting factor $Z=4$, each zero element is replaced with a 4×4 all zero matrix 11a. If $P_{2,3}=2$, a non-zero-element in row 2 and column 3 is replaced with a 4×4 circular permutation matrix 11d. The matrix is obtained by circularly shifting a 4×4 identity matrix 11b to the right

twice. If $P_{2,4} = 0$, a non-zero-element in row 2 and column 4 is replaced with the identity matrix 11b. It should be noted that only examples are described herein, and the examples do not constitute a limitation.

5 [0066] Value of P_{ij} may depend on the lifting factor Z . Therefore, for an element of 1 (a non-zero-element) in row i and column j of the base graph, P_{ij} may be different for different lifting factors Z . For ease of implementation, usually, an $m \times n$ base matrix (base matrix) is defined in the system. Each element in the base matrix is in a one-to-one correspondence with each element in the base graph. A zero-element in the base graph has a same position in the base matrix, and the element is indicated by -1 . A non-zero-element indicated by 1 in row i and column j in the base graph has a same position in the base matrix, and the non-zero-element is indicated by a value V_{ij} , where V_{ij} may be a shift value defined relative to a preset or a particular lifting factor Z , for example, a shift value relative to a maximum lifting factor Z_{\max} in a set to which the lifting factor Z belongs. In this way, V_{ij} may be a shift value of the non-zero-element in row i and column j when the maximum lifting factor Z_{\max} in the set to which Z belongs is used. In this embodiment of this application, the base matrix is also referred to as a shift matrix of a matrix of the base graph sometimes.

15 [0067] P_{ij} may be obtained based on V_{ij} and Z . For example, it may be expressed as $P_{ij} = f(V_{ij}, Z)$, where $f(V_{ij}, Z)$ is a function using V_{ij} and Z as parameters. For example,

$$P_{i,j} = \begin{cases} -1 & V_{i,j} = -1 \\ \text{mod}(V_{i,j}, Z) & V_{i,j} \geq 0 \end{cases}$$

20 [0068] As shown in FIG. 1, 10b is a base matrix corresponding to the base graph 10a.

[0069] Usually, the base graph or the base matrix of the LDPC code may include p columns corresponding to built-in puncture (built-in puncture) bits, where p may be an integer from 0 to 2. These columns may be used in encoding, but systematic bits corresponding to the built-in puncture bits are not sent. A code rate of the base matrix of the LDPC code satisfies $R = (n - m)/(n - p)$. For a base matrix including 4 rows and 20 columns (4×20), if there are two columns corresponding to built-in puncture bits, a code rate is $(20-4)/(20-2) = 8/9$.

[0070] For an LDPC code used in a wireless communication system, a matrix of a base graph of the LDPC code has a size of $m \times n$, and the base graph may include five submatrices: A, B, C, D, and E. A weight of the matrix is determined by a quantity of non-zero-elements, a row weight of a row (a row weight) refers to a quantity of non-zero-elements in the row, and a column weight of a column (a column weight) refers to a quantity of non-zero-elements in the column.

[0071] As shown in 200 in FIG. 2: submatrix A is a matrix including m_A rows and n_A columns, the submatrix A has a size of $m_A \times n_A$. Each column corresponds to Z systematic bits in the LDPC

code, and a systematic bit is sometimes referred to as an information bit.

5 [0072] Submatrix B is a square matrix of m_A rows and m_A columns, and the submatrix B has a size of $m_A \times m_A$. Each column corresponds to Z parity bits in the LDPC code. As shown in 20a of FIG. 2, the submatrix B includes a submatrix B' with a bi-diagonal structure, and a matrix
column whose weight is 3 (for short, weight-3 column), and the weight-3 column may be located at the left side of the submatrix B'. The submatrix B may further include one or more matrix
columns whose column weights are 1 (for short, weight-1 column). For example, a possible implementation is shown in 20b or 20c in FIG. 2.

10 [0073] Generally, a matrix generated based on the submatrices A and B is a core matrix, which may be used to support high-code rate encoding.

[0074] Continuing in FIG. 2, submatrix C is an all zero matrix, and the submatrix C has a size of $m_A \times m_D$. Submatrix E is an identity matrix, and the submatrix E has a size of $m_D \times m_D$.

[0075] Submatrix D has a size of $m_D \times (n_A + m_A)$, and the submatrix D may be used to generate parity bits with low code rate.

15 [0076] It may be understood that the base graph is described above from a mathematical definition perspective, and because submatrix C is an all zero matrix, and submatrix E is an identity matrix. Therefore, in a possible implementation, a matrix including the submatrix A and submatrix B, or a matrix including the submatrix A, the submatrix B, and the submatrix D may be used to represent a base graph of a matrix in encoding or decoding.

20 [0077] Because structures of the submatrix C and the submatrix E are relatively fixed, structures of the submatrix A, the submatrix B, and the submatrix D are determining factors affecting encoding and decoding performance of the LDPC code.

[0078] When an LDPC matrix with a raptor-like structure is used for encoding, in a possible implementation, the part of the matrix including the submatrix A and the submatrix B, namely, a
25 core matrix, may be first used for encoding to obtain one or more parity bits corresponding to the submatrix B. Then the entire matrix is used for encoding to obtain one or more parity bits corresponding to the submatrix E. Because the submatrix B may include a submatrix B' with a bi-diagonal structure and a weight-1 column. Therefore, during the encoding, one or more parity bits corresponding to the bi-diagonal structure may be first obtained, and then one or more parity bits
30 corresponding to the weight-1 column are obtained.

[0079] The following provides an example of encoding method. Assuming that the core matrix including the submatrix A and the submatrix B is H_{core} , a weight-1 column and a row in which a non-zero-element in the weight-1 column is located are removed from the H_{core} to obtain a matrix $H_{\text{core-dual}}$. A matrix block in the $H_{\text{core-dual}}$ corresponding to parity bits is represented by $H_e = [H_{e1}$

H_{e2}], where H_{e1} is a weight-3 column, and H_{e2} has a bi-diagonal structure. According to a definition of an LDPC code matrix, $H_{\text{core-dual}} \cdot [S \ P_e]^T = 0$, where S is an input sequence and is a vector including information bits, P_e is a vector including parity bits, and $[S \ P_e]^T$ indicates a transposed matrix including the input sequence S and P_e . Therefore, parity bits corresponding to $H_{\text{core-dual}}$ may be calculated first according to the input sequence S and $H_{\text{core-dual}}$. The input sequence S includes all information bits. Then, parity bits corresponding to the weight-1 column in the submatrix B is calculated according to the obtained parity bits corresponding to $H_{\text{core-dual}}$ and the input sequence S . In this case, all parity bits corresponding to the submatrix B may be obtained. Then, parity bits corresponding to the submatrix E is obtained by encoding using the submatrix D and based on the input sequence S and the obtained parity bits corresponding to the submatrix B . In this way, all the information bits and all parity bits are obtained. These bits form an encoded sequence, that is, LDPC codeword(s).

[0080] Optionally, LDPC encoding may further include shortening (shortening) and puncturing (puncturing) operations. The shortened bits and the punctured bits are not sent.

[0081] The shortening is usually performed starting from the last bit of information bits, and may be performed in different manners. For example, for a quantity of shortened bits is s_0 , the last s_0 bits in the input sequence S may be set as known bits, such as set to 0 or null or other values, to obtain an input sequence S' , and then the input sequence S' is encoded by using an LDPC matrix. For another example, the last $(s_0 \bmod Z)$ bits in the input sequence S may be set as known bits, such as set to 0 or null or other values, to obtain an input sequence S' , and the last $\left\lfloor \frac{s_0}{Z} \right\rfloor$ columns in the submatrix A are deleted to obtain an LDPC matrix H' , and the input sequence S' is encoded by using the LDPC matrix H' , or the last $\left\lfloor \frac{s_0}{Z} \right\rfloor$ columns in the submatrix A do not participate in encoding of the input sequence S' . After the encoding is completed, the shortened bits are not sent.

[0082] The puncturing may be performed on one or more columns corresponding to built-in puncture bits, or one or more parity bits in an input sequence. Usually puncturing one or more parity bits is also from the last one bit in parity bits. Alternatively, puncturing parity bit(s) may be performed according to a preset puncturing pattern in the system. In a possible implementation, an input sequence is first encoded, and then based on a quantity p of bits that need to be punctured, the last p bit(s) in parity bits are selected, or p bit(s) are selected according to the preset puncturing pattern in the system, where the p bit(s) are not sent. In another possible implementation, p column(s) of a matrix corresponding to the punctured bits and p rows in which non-zero-elements in these columns are located may be determined, and the rows and the columns do not participate

in encoding, and therefore no corresponding parity bits are generated.

[0083] It should be noted that the encoding implementations described herein are merely used as examples. Other known encoding implementations may alternatively be used based on the base graph and/or the base matrix provided in this application. And the encoding implementations are not limited in this application. Decoding in this application may be performed in various decoding methods, for example, a min-sum (MS) decoding method, or a belief propagation decoding method. The MS decoding method may also be referred to as a flood MS decoding method sometimes. For example, an input sequence is initialized, and an iteration is performed. Hard decision detection is performed after the iteration, and a hard decision result is checked. If the decoding result meets a check equation, decoding succeeds, the iteration ends, and the decision result is output. If the decoding result does not meet a check equation, an iteration is performed again within a maximum quantity of iteration times. If the check still fails when the maximum quantity of iteration times is reached, the decoding fails. It may be understood that the principle of the MS decoding is conventionally known, and details are not described herein again.

[0084] It should be noted that the decoding method is merely used as an example herein, other decoding methods known may alternatively be used based on the base graph and/or the base matrix provided in this application, and the decoding manner is not limited in this application.

[0085] An LDPC code may be obtained based on a base graph and a base matrix, an upper limit of performance of the LDPC code may be determined by performing density evolution on the base graph or the base matrix. An error floor of the LDPC code is determined based on a shift value in the base matrix. Improving encoding performance and decoding performance and lowering the error floor are some of objectives of designing the base graph and the base matrix. In the wireless communication system, code lengths are widely varied. For example, a code length may be 40 bits, 1280 bits, or the like. FIG. 3a and FIG. 3b-1 to FIG. 3b-8 are examples of a base graph and base matrices of a core matrix of the LDPC code. The examples may meet performance requirements of code blocks having a block length of 20 to 2560 bits. For ease of description and understanding, column indexes and row indexes are respectively shown on the uppermost side and the leftmost side in FIG. 3a and FIG. 3b-1 to FIG. 3b-8.

[0086] FIG. 4 is a performance diagram based on the LDPC code shown in FIG. 3a and FIG. 3b-1 to FIG. 3b-8. An LDPC 1 indicates an LDPC code obtained by encoding based on a base matrix corresponding to a base graph 30a, and LDPC 2 indicates a commonly used LDPC code used for comparison. A horizontal coordinate indicates a length of an information bit sequence, and a unit of length is bit. A vertical coordinate indicates a symbol signal-to-noise ratio (E_s/N_0). Performance curves indicate performance of a symbol signal-to-noise ratio for the LDPC 1 and

the LDPC 2 in case of different information bit sequence lengths when a BLER is 0.0001. It may be learned that at a same BLER, a symbol signal-to-noise ratio of the LDPC 1 is less than that of the LDPC 2 in case of different information bit sequence lengths, that is, performance of the LDPC 1 is better than that of the LDPC 2.

5 [0087] FIG. 3a shows an example of a base graph 30a of an LDPC code. The matrix of the base graph 30a has 42 rows and 52 columns. In the figure, 0 to 51 in the uppermost row indicate column indexes, and 0 to 41 in the leftmost column indicate row indexes.

[0088] In the base graph 30a, submatrix A corresponds to systematic bits and has m_A rows and 10 columns, where $4 \leq m_A \leq 7$. For example, if $m_A = 4$, the submatrix A includes elements in row 0 to row 3 and column 0 to column 9 in the base graph 30a. For another example, if $m_A > 4$, using $m_A = 7$ as an example, the submatrix A includes elements in row 0 to row 6 and column 0 to column 9 in the base graph 30a.

[0089] Submatrix B corresponds to parity bits, has m_A rows and m_A columns, and includes elements in row 0 to row $(m_A - 1)$ and column 10 to column $(10 + m_A - 1)$ in the base graph 30a.

15 [0090] The submatrix A and the submatrix B form a core matrix of the base graph of an LDPC code, that is, a matrix including m_A rows and $(m_A + n_A)$ columns. The matrix may be used for high-code rate encoding. For ease of description, using $m_A = 7$ as an example below, the core matrix of the base graph of the LDPC code is 7 rows and 17 columns.

[0091] The submatrix A may include two columns corresponding to built-in puncture bits. 20 After puncturing, a code rate that can be supported by the core matrix is $10/(17-2) = 2/3$.

[0092] The submatrix B includes one weight-3 column, that is, a column weight of column 0 of the submatrix B (column 10 of the core matrix) is 3. A matrix including column 1 to column 3 (column 11 to column 13 in the core matrix) and row 0 to row 3 in the submatrix B is of a bi-diagonal structure. The submatrix B further includes three weight-1 columns.

25 [0093] Using $m_A = 7$ as an example, the core matrix of the base graph 30a includes two rows whose weights are 10, two rows whose weights are 8, two rows whose weights are 6, and one row whose weight is 4. That is, row weights of rows in the core matrix including the submatrix A and the submatrix B are respectively 8, 10, 8, 10, 4, 6, and 6. It should be noted that the rows in the core matrix may be switched, for example, row 0 is switched with row 2, row 1 is switched with row 3, and the like. Each of the rows in the core matrix may be one of rows shown in row 0 to row 6 and column 0 to column 16 in the core matrix of the base graph 30a. The rows may be switched with each other, and the columns may also be switched with each other. For example, column 8 may be switched with column 14 in the core matrix. It should be noted that, only 30

examples are provided herein. In an actual application, column permutation and row permutation may be flexibly designed based on a system requirement.

5 [0094] It may be understood that because in a matrix, rows may be switched with each other, columns may also be switched with each other, row permutation does not change weights of columns, and column permutation does not change weights of rows, a quantity of non-zero-elements in the matrix does not change. After row permutation and column permutation, weights of rows in a base graph do not change. Use of a base graph obtained after row permutation, column permutation, or row permutation and column permutation does not affect performance.

10 [0095] It should be noted that in this application, that performance is not affected means: On the whole, impact is acceptable and falls within a tolerance range. For example, in some scenarios or in some ranges, the performance is lowered in an allowable range. However, in some scenarios or some ranges, the performance is improved. On the whole, there is little impact on the performance.

15 [0096] Usually, for a given base graph or a given base matrix of an LDPC code, impact on performance caused by few modifications to matrix elements is acceptable. For example, in an implementation, few modifications may be made based on the core matrix of the base graph 30a. For example, a weight of one row is greater than or equal to 2 and less than or equal to 5, and weights of other six rows are greater than or equal to 6 and less than or equal to 12. It may be understood that referring to the solution provided in this application, weights of some rows may
20 be increased or decreased by 1 or 2. This is not limited in this application.

[0097] To obtain flexible code rates, a submatrix C, a submatrix D, and a submatrix E of corresponding sizes may be added based on the core matrix. Because the submatrix C is an all zero matrix and the submatrix E is an identity matrix, sizes of the matrices are determined according to code rates, and structures of the matrices are relatively fixed. Encoding performance
25 and decoding performance are mainly affected by the core matrix and the submatrix D. Different code rates may be obtained by adding rows and columns based on the core matrix to form the corresponding submatrices C, D, and E. For example, the core matrix of the base graph 30a may be used as the core matrix, and the corresponding submatrices C, D, and E are added to satisfy requirements of encoding or decoding for different code rates,.

30 [0100] A column count m_D of the submatrix D is a sum of a column count of the submatrix A and a column count of the submatrix B, and a row count of the submatrix D is mainly related to a code rate. Using the base graph 30a as an example, if $m_A = 4$, a corresponding column count of the submatrix D is $(n_A + m_A) = 14$, or if $m_A = 7$, a corresponding column count of the submatrix D is $(n_A + m_A) = 17$. If a code rate supported by the LDPC code is R_m , a base graph or a base matrix of

the LDPC code has a size of $m \times n$, where $n = n_A / R_m + p$ and $m = n - n_A = n_A / R_m + p - n_A$. If a minimum code rate $R_m = 1/5$, and a quantity p columns corresponding to the built-in puncture bits is 2, using the base graph 30a as an example, $n = 52$ and $m = 42$. A row count m_D of the submatrix D may be up to $m - m_A = 42 - m_A$, and if $m_A = 4$, $0 \leq m_D \leq 38$, or if $m_A = 7$, $0 \leq m_D \leq 35$.

5 **[0101]** For ease of description, a matrix F of m_F rows and $(m_A + n_A)$ columns may be defined, so that the submatrix D may include m_D rows in the matrix F, where $0 \leq m_D \leq m_F$, and $35 \leq m_F \leq 38$. Still using $m_A = 7$ as an example, in the base graph 30a, $m_A + m_D = 42$. If $m_D = 35$, correspondingly, the submatrix D includes 35 rows and 17 columns. To be specific, the submatrix D is the matrix F, and the code rate supported by the corresponding LDPC code is $10/50 = 1/5$. It may be learned that for $m_A = 7$, a matrix including row 7 to row 41 and column 0 to column 17 in the base graph 30a is the matrix F. For $m_A = 4$, a matrix including row 4 to row 41 and column 0 to column 13 in the base graph 30a is the matrix F. It should be noted that, only examples are provided herein, and the present application is not limited thereto. m_A may alternatively be any integer value from 4 to 7, and the column count of the matrix F also correspondingly changes.

15 **[0102]** In the present application, if there is at most one non-zero-element in a same column in two adjacent rows in the base graph, the two rows are mutually orthogonal. In other columns different from some columns for two adjacent rows in the base graph, if there is at most one non-zero-element in a same column of the other columns for two adjacent rows in the base graph, the two rows are quasi-orthogonal.

20 **[0103]** The matrix F may include a plurality of rows having a quasi-orthogonal structure and at least two rows having an orthogonal structure. For example, the matrix F includes at least 15 rows satisfying the quasi-orthogonal structure. In columns other than the f columns corresponding to built-in puncture bits in any two adjacent rows in the 15 rows, there is at most one non-zero-element in a same column, that is, a matrix block including the columns other than the columns corresponding to built-in puncture bits in the at least 15 rows in the matrix F has an orthogonal structure. The matrix F may further include 10 to 20 rows satisfying the orthogonal structure. In these rows, there is at most one non-zero-element in a same column in any two adjacent rows. To be specific, there is also at most one non-zero-element in a built-in puncture column.

25 **[0104]** For example, using the base graph 30a as an example, the last 10 rows in the matrix F has an orthogonal structure, weights of nine rows are 3, and a weight of one row is 2. Column weight distribution of the matrix F may be: a weight of one column is 16, a weight of one column is 18, a weight of one column is 11, weights of two columns are 10, a weight of one column is 9, a weight of one column is 8, a weight of one column is 7, a weight of one column is 6, weights of

two columns are 4, a weight of one column is 3, and weights of two columns are 2. If $m_A > 4$, weights of other columns in the matrix F are 0.

5 [0105] Using $m_A = 7$ as an example, in an example of the matrix F in the base graph 30a, row weights of the matrix F are 5, 3, 4, 4, 4, 3, 4, 4, 3, 4, 4, 3, 3, 3, 3, 2, 3, 3, 2, 4, 2, 3, 2, 4, 2, 3, 3, 3, 3, 3, 2, 3, 3, 3, and 3 in sequence.

[0106] Because the submatrix E is an identity matrix, weights of rows in the base graph 30a are respectively 8, 10, 8, 10, 4, 6, 6, 6, 4, 5, 5, 5, 4, 5, 5, 4, 5, 5, 4, 4, 4, 4, 3, 4, 4, 3, 5, 3, 4, 3, 5, 3, 4, 4, 4, 4, 3, 4, 4, 4, and 4.

10 [0107] Still using $m_A = 7$ as an example, if $m_D = 15$, the submatrix D in the base graph of the LDPC code may include 15 rows and 17 columns. The submatrix D may be a matrix including row 0 to row 14 in the matrix F in the base graph 30a, that is, row 7 to row 21, and column 0 to column 16 in the base graph 30a. A code rate supported by the corresponding LDPC code is $10/30 = 1/3$. That is, at the code rate, the base graph of the LDPC code corresponds to a matrix including row 0 to row 21 and column 0 to column 31 in the base graph 30a. The submatrix E is an identity matrix including 15 rows and 15 columns, and the submatrix C is an all zero matrix including 7 rows and 15 columns.

15 [0108] If $m_D = 25$, the submatrix D in the base graph of the LDPC code has 25 rows and 17 columns. The submatrix D may be a matrix including row 0 to row 24 in the matrix F in the base graph 30a, that is, row 7 to row 31, and column 0 to column 16 in the base graph 30a. A code rate supported by the corresponding LDPC code is $10/40 = 1/4$. That is, at the code rate, the base graph of the LDPC code corresponds to a matrix including row 0 to row 31 and column 0 to column 41 in the base graph 30a. The submatrix E is an identity matrix including 25 rows and 25 columns, and the submatrix C is an all zero matrix including 7 rows and 25 columns.

20 [0109] The rest can be deduced by analogy, and details are not described one by one.

25 [0110] It should be noted that in the base graph and the base matrix of the LDPC code, rows may be switched with each other, and columns may also be switched with each other. For example, in the base graph 30a, row 34 may be switched with row 36, and column 44 may be switched with column 45. For another example, the submatrix D includes m_D rows in the matrix F, the m_D rows may not be switched, or one or more of the m_D rows may be switched, the submatrix E is still of a diagonal structure, and neither row permutation nor column permutation is performed on the submatrix E. For example, row 27 is switched with row 29 in the matrix F, the submatrix D includes m_D rows in the matrix F, and the submatrix E is still of the diagonal structure. The matrix F is a quasi-orthogonal matrix before the row permutation, and is still a quasi-orthogonal

matrix by performing row permutation. It may be understood that if the base graph or the base matrix includes the submatrix D, when columns in the core matrix are switched, corresponding columns in the submatrix D also need to be switched.

5 [0111] As shown in FIG. 3b-1 to FIG. 3b-8, base matrices 30b-1 to 30b-8 are examples of a plurality of base matrices of the base graph 30a. A non-zero-element in row i and column j in the base graph 30a has a same position in each of the base matrices 30b-1 to 30b-8, and a value of the non-zero-element is a shift value $V_{i,j}$. A zero-element in a shift matrix is represented by using -1 or null. A part corresponding to the submatrix D in the base matrix may include m_D rows in a shift matrix of the matrix F, and values of m_D may be selected according to different code rates. A shift matrix corresponding to the submatrix D includes m_D rows in the shift matrix of the matrix F.

10 [0112] In a possible implementation, the shift matrix of the matrix F may be a matrix including row 7 to row 41 and column 0 to column 16 in any one of matrices 30b-1 to 30b-8, or a matrix obtained by performing row/column permutation on the matrix including row 7 to row 41 and column 0 to column 16 in any one of matrices 30b-1 to 30b-8; or the shift matrix of the matrix F may include a matrix including row 4 to row 41 and column 0 to column 14 in any one of matrices 30b-1 to 30b-8, or a matrix obtained by performing row/column permutation on the matrix including row 4 to row 41 and column 0 to column 14 in any one of matrices 30b-1 to 30b-8.

15 [0113] To support different block lengths, the LDPC code needs different lifting factors Z. For example, lifting factors $Z = a \times 2^j$, where $a \in \{2, 3, 5, 7, 9, 11, 13, 15\}$ may be divided into eight sets shown in Table 1:

Table 1

Set 1	$Z = 2 \times 2^j$, where $j = 0, 1, 2, 3, 4, 5, 6, 7$
Set 2	$Z = 3 \times 2^j$, where $j = 0, 1, 2, 3, 4, 5, 6, 7$
Set 3	$Z = 5 \times 2^j$, where $j = 0, 1, 2, 3, 4, 5, 6$
Set 4	$Z = 7 \times 2^j$, where $j = 0, 1, 2, 3, 4, 5$
Set 5	$Z = 9 \times 2^j$, where $j = 0, 1, 2, 3, 4, 5$
Set 6	$Z = 11 \times 2^j$, where $j = 0, 1, 2, 3, 4, 5$
Set 7	$Z = 13 \times 2^j$, where $j = 0, 1, 2, 3, 4$
Set 8	$Z = 15 \times 2^j$, where $j = 0, 1, 2, 3, 4$

[0114] To ensure LDPC code performance in different block lengths, based on the sets of

different lifting factors Z , base matrices corresponding to the sets of the different lifting factors Z may be separately used.

[0115] In a possible implementation:

[0116] If the lifting factor Z is one lifting factor in the set 1, the shift matrix of the matrix F may be the matrix including row 7 to row 41 and column 0 to column 16 in 30b-1, or the matrix obtained by performing row/column permutation on the matrix including row 7 to row 41 and column 0 to column 16 in 30b-1; or the shift matrix of the matrix F may be the matrix including row 4 to row 41 and column 0 to column 14 in 30b-1, or the matrix obtained by performing row/column permutation on the matrix including row 4 to row 41 and column 0 to column 14 in 30b-1. Correspondingly, the base matrix of the base graph 30a may be the matrix shown in 30b-1, or the matrix obtained by performing row/column permutation on the matrix shown in 30b-1.

[0117] If the lifting factor Z is one lifting factor in the set 2, the shift matrix of the matrix F may be the matrix including row 7 to row 41 and column 0 to column 16 in 30b-2, or the matrix obtained by performing row/column permutation on the matrix including row 7 to row 41 and column 0 to column 16 in 30b-2; or the shift matrix of the matrix F may be the matrix including row 4 to row 41 and column 0 to column 14 in 30b-2, or the matrix obtained by performing row/column permutation on the matrix including row 4 to row 41 and column 0 to column 14 in 30b-2. Correspondingly, the base matrix of the base graph 30a may be the matrix shown in 30b-2, or the matrix obtained by performing row/column permutation on the matrix shown in 30b-2.

[0118] If the lifting factor Z is one lifting factor in the set 3, the shift matrix of the matrix F may be the matrix including row 7 to row 41 and column 0 to column 16 in 30b-3, or the matrix obtained by performing row/column permutation on the matrix including row 7 to row 41 and column 0 to column 16 in 30b-3; or the shift matrix of the matrix F may be the matrix including row 4 to row 41 and column 0 to column 14 in 30b-3, or the matrix obtained by performing row/column permutation on the matrix including row 4 to row 41 and column 0 to column 14 in 30b-3. Correspondingly, the base matrix of the base graph 30a may be the matrix shown in 30b-3, or the matrix obtained by performing row/column permutation on the matrix shown in 30b-3.

[0119] If the lifting factor Z is one lifting factor in the set 4, the shift matrix of the matrix F may be the matrix including row 7 to row 41 and column 0 to column 16 in 30b-4, or the matrix obtained by performing row/column permutation on the matrix including row 7 to row 41 and column 0 to column 16 in 30b-4; or the shift matrix of the matrix F may be the matrix including row 4 to row 41 and column 0 to column 14 in 30b-4, or the matrix obtained by performing row/column permutation on the matrix including row 4 to row 41 and column 0 to column 14 in 30b-4. Correspondingly, the base matrix of the base graph 30a may be the matrix shown in 30b-

4, or the matrix obtained by performing row/column permutation on the matrix shown in 30b-4.

5
[0120] If the lifting factor Z is one lifting factor in the set 5, the shift matrix of the matrix F may be the matrix including row 7 to row 41 and column 0 to column 16 in 30b-5, or the matrix obtained by performing row/column permutation on the matrix including row 7 to row 41 and column 0 to column 16 in 30b-5; or the shift matrix of the matrix F may be the matrix including row 4 to row 41 and column 0 to column 14 in 30b-5, or the matrix obtained by performing row/column permutation on the matrix including row 4 to row 41 and column 0 to column 14 in 30b-5. Correspondingly, the base matrix of the base graph 30a may be the matrix shown in 30b-5, or the matrix obtained by performing row/column permutation on the matrix shown in 30b-5.

10
[0121] If the lifting factor Z is one lifting factor in the set 6, the shift matrix of the matrix F may be the matrix including row 7 to row 41 and column 0 to column 16 in 30b-6, or the matrix obtained by performing row/column permutation on the matrix including row 7 to row 41 and column 0 to column 16 in 30b-6; or the shift matrix of the matrix F may be the matrix including row 4 to row 41 and column 0 to column 14 in 30b-6, or the matrix obtained by performing row/column permutation on the matrix including row 4 to row 41 and column 0 to column 14 in 30b-6. Correspondingly, the base matrix of the base graph 30a may be the matrix shown in 30b-6, or the matrix obtained by performing row/column permutation on the matrix shown in 30b-6.

15
[0122] If the lifting factor Z is one lifting factor in the set 7, the shift matrix of the matrix F may be the matrix including row 7 to row 41 and column 0 to column 16 in 30b-7, or the matrix obtained by performing row/column permutation on the matrix including row 7 to row 41 and column 0 to column 16 in 30b-7; or the shift matrix of the matrix F may be the matrix including row 4 to row 41 and column 0 to column 14 in 30b-7, or the matrix obtained by performing row/column permutation on the matrix including row 4 to row 41 and column 0 to column 14 in 30b-7. Correspondingly, the base matrix of the base graph 30a may be the matrix shown in 30b-7, or the matrix obtained by performing row/column permutation on the matrix shown in 30b-7.

20
[0123] If the lifting factor Z is one lifting factor in the set 8, the shift matrix of the matrix F may be the matrix including row 7 to row 41 and column 0 to column 16 in 30b-8, or the matrix obtained by performing row/column permutation on the matrix including row 7 to row 41 and column 0 to column 16 in 30b-8; or the shift matrix of the matrix F may be the matrix including row 4 to row 41 and column 0 to column 14 in 30b-8, or the matrix obtained by performing row/column permutation on the matrix including row 4 to row 41 and column 0 to column 14 in 30b-8. Correspondingly, the base matrix of the base graph 30a may be the matrix shown in 30b-8, or the matrix obtained by performing row/column permutation on the matrix shown in 30b-8.

25
[0124] For example, a value of the lifting factor Z is determined based on a length K of the

input sequence. For example, if the length of the input sequence is K , a minimum value that meets $10 \times Z \geq K$ may be determined from a plurality of lifting factors defined in a system and used as the value of the lifting factor of the matrix. Further, a corresponding base matrix may be selected according to the determined lifting factor.

5 [0125] Similarly, rows in the base matrix may also be switched with each other, and columns in the base matrix may also be switched with each other. If at least one of row permutation or column permutation is performed on the base graph, same permutation is also performed on the corresponding rows or columns in the base matrix.

[0126] It may be understood that in this application, the quasi-orthogonal structure is not
10 limited to only two adjacent rows. A matrix including the quasi-orthogonal structure may alternatively be designed to include a plurality of groups, each group includes at least two rows, for example, 3 rows or 4 rows, and rows included in each group are quasi-orthogonal.

[0127] In the performance curve diagram shown in FIG. 4, LDPC 1 indicates that the LDPC
15 LDPC 2 indicates a commonly used LDPC code used for comparison. A horizontal coordinate indicates a length of an information bit sequence, and a unit of length is bit. A vertical coordinate is a symbol signal-to-noise ratio (E_s/N_0). Performance curves indicate performance of a symbol signal-to-noise ratio for LDPC 1 and LDPC 2 in case of different information bit sequence lengths when BLER is 0.0001. It may be learned that at a same BLER, a symbol signal-to-noise ratio of
20 LDPC 1 is less than that of LDPC 2 in case of different information bit sequence lengths, that is, performance of LDPC 1 is better than that of LDPC 2.

[0128] In an encoding method provided in an embodiment of the present application, an
encoder encodes an input sequence by using an LDPC matrix. A base graph of the LDPC matrix may be any base graph in the foregoing examples, and a base matrix of the LDPC matrix may be
25 any base matrix in the foregoing examples. The input sequence of the encoder may be an information bit sequence, or may be an information bit sequence obtained through at least one type of the following processing: CRC bits attachment or filler bits insertion.

[0129] Further, the method includes: determining a lifting factor Z . A value of the lifting factor
30 Z may be determined based on a length K of the input sequence. The information bit sequence may also be referred to as a code block (code block) sometimes, and may be obtained through code block segmentation on a transport block. If the length of the information bit sequence is K , a minimum value that meets $10 \times Z \geq K$ may be determined from a plurality of lifting factors defined in a system as the value of the lifting factor Z . For example, if $K = 128$ and the lifting factors defined in the system include lifting factors in the sets in Table 1, for example, 2, 3, 4, 5,

6, 7, 8, 9, 10, 11, 12, 13, 14, 15, 16, 18, 20, 22, 24, 26, 28, 30, 32, 36, 40, 44, 48, 52, 56, 60, 64, 72, 80, 88, 96, 104, 112, 120, 128, 144, 160, 176, 192, 208, 224, 240, and 256, it may be determined that Z is 13 and is in the set 7. It should be noted that only examples are provided herein, and the examples do not constitute a limitation.

5 [0130] In another possible design, Kb may be a column count of columns corresponding to information bits in a base matrix of an LDPC code. In a supported lifting factor set, a minimum value Z_0 that meets $Kb \cdot Z_0 \geq K$ may be determined as the value of the lifting factor Z . In the base graph 30a, the column count Kb_{max} of columns corresponding to information bits is 10, and it is assumed that a lifting factor set supported by the base graph 30a is {24, 26, 28, 30, 32, 36, 40, 44,
10 48, 52, 56, 60, 64, 72, 80, 88, 96, 104, 112, 120, 128, 144, 160, 176, 192, 208, 224, 240, 256, 288, 320, 352, 384}.

[0131] If the length K of the input sequence is 529 bits, Z is 26. If the length K of the input sequence is 5000 bits, Z is 240. It should be noted that only examples are provided herein, and the examples do not constitute a limitation.

15 [0132] For another example, a value of Kb may also vary with a value of K , but the value of Kb does not exceed the column count of columns corresponding to the information bits in the base matrix of the LDPC code. For example, different thresholds may be set for Kb .

[0133] A possible design is as follows: It should be noted that threshold values 640, 560, or 192 herein are only examples. Other values may be designed according to a system design
20 requirement.

```
if (K > 640), Kb = 10;  
elseif (K > 560), Kb = 9;  
elseif (K > 192), Kb = 8;  
else Kb = 6; end
```

25 [0134] Wherein the lifting factor Z may be determined by the encoder according to the length K of the input sequence, or may be obtained by the encoder from other entities (such as a processor).

[0135] In a possible design, a value of a filler bit may be null, or 0, or other values defined in a system. After encoding, the filler bits can be identified and are not sent. The present application
30 is not limited thereto.

[0136] The encoding, by the encoder, an input sequence by using an LDPC matrix H may be encoding the input sequence by using the LDPC matrix H corresponding to the lifting factor Z .

[0137] In a possible implementation, an input sequence is $c = \{c_0, c_1, c_2, \dots, c_{K-1}\}$, a length of the input sequence c is K , and an output sequence obtained after the input sequence c is encoded by

the encoder is $d = \{d_0, d_1, d_2, \dots, d_{N-1}\}$, where K is an integer greater than 0, and K may be an integer multiple of the lifting factor Z .

[0138] The output sequence d includes K_0 bits in the input sequence c and parity bits in a parity bit sequence w , where K_0 is an integer greater than 0 and less than or equal to K . A length of the parity bit sequence w is $N - K_0$, where $w = \{w_0, w_1, w_2, \dots, w_{N-K_0-1}\}$.

[0139] The parity bit sequence w and the input sequence c meet Formula (1):

$$H \times \begin{bmatrix} c^T \\ w^T \end{bmatrix} = 0^T \quad (1),$$

where $c^T = [c_0, c_1, c_2, \dots, c_{K-1}]^T$, c^T is a transposed vector of a vector including bits in the input sequence, and $w^T = [w_0, w_1, w_2, \dots, w_{N-K_0-1}]^T$, w^T is a transposed vector of a vector including bits in the parity bit sequence, where 0^T is a column vector, and values of all elements of 0^T are 0.

[0140] H is an LDPC matrix obtained based on any base graph described in the foregoing embodiments, a base graph of H has m rows and n columns, and may be the base graph 30a mentioned in the foregoing embodiments.

[0141] In a design, the base graph of H includes p built-in puncture columns, where p is an integer greater than or equal to 0, and information bits corresponding to the p built-in puncture columns are not output, and the output sequence does not include the information bits corresponding to the p built-in puncture columns. In this case, $K_0 = K - p \cdot Z$. For example, if $p = 2$, $K_0 = K - 2 \cdot Z$ and the length of the parity bit sequence w is $N + 2 \cdot Z - K$. If the p built-in puncture columns participate in encoding, $K_0 = K$ and the length of the parity bit sequence w is $N - K$.

[0142] Correspondingly, H may have M rows and $(N + p \cdot Z)$ columns or M rows and N columns, and a size of the base graph of H is: $m = M/Z$ rows and $n = \frac{(N + p \cdot Z)}{Z}$ columns.

[0143] The base graph of the LDPC matrix H may be represented as $[H_{BG} \ H_{BG,EXT}]$, where

$$H_{BG,EXT} = \begin{bmatrix} \mathbf{0}_{m_c \times n_c} \\ I_{n_c \times n_c} \end{bmatrix}, \quad \mathbf{0}_{m_c \times n_c} \text{ represents an all zero matrix of size } m_c \times n_c, \text{ and } I_{n_c \times n_c}$$

represents an identity matrix of size $n_c \times n_c$. Because K_b may vary with K , H_{BG} includes K_b columns corresponding to information bits in H_{BG2} and includes column 10 to column $(10 + m_A - 1)$ in H_{BG2} , a column count in H_{BG2} is $10 + m_A$, where $4 \leq m_A \leq 7$. For example, if $K_b \in \{6, 8, 9\}$, H_{BG} may be obtained after column K_b to column 9 are deleted from H_{BG2} . If $K_b = 10$, $H_{BG} = H_{BG2}$.

[0144] In a possible design, $\mathbf{0}_{m_c \times n_c}$ is the submatrix C in the base graph in the foregoing

embodiments, and $I_{n_c \times n_c}$ is the submatrix E in the foregoing embodiments, so that

$$H_{BG2} = \begin{bmatrix} [A & B] \\ D \end{bmatrix},$$

where A, B, and D are respectively the submatrices A, B, and D in the base

graph in the foregoing embodiments. Therefore, $m_c = 7$, $0 \leq n_c \leq 35$, a row count in H_{BG2} is less than or equal to 42 and is greater than or equal to 4, and the column count in H_{BG2} is equal to 17.

5 [0145] In another possible design, because column 14 to column 16 are weight-1 columns and non-zero-elements in these columns are in row 4 to row 6, therefore, $m_c = 6$, $0 \leq n_c \leq 36$, and the column count in H_{BG2} is 16; or $m_c = 5$, $0 \leq n_c \leq 37$, and the column count in H_{BG2} is 15; or $m_c = 4$, $0 \leq n_c \leq 38$, and the column count in H_{BG2} is 14.

[0146] Correspondingly, the LDPC matrix H may be represented by $H = [H_1 \ H_2]$.

10 [0147] H_1 may be obtained by replacing each zero-element in H_{BG} with an all zero matrix of size $Z \times Z$, and replacing each non-zero-element with a circular permutation matrix h_{ij} of size $Z \times Z$, where the circular permutation matrix h_{ij} is obtained by circularly shifting an identity matrix of size $Z \times Z$ to the right P_{ij} times, and h_{ij} may also be represented by $I(P_{ij})$, where i is a row index and j is a column index. In a possible design, $P_{ij} = \text{mod}(V_{ij}, Z)$, where V_{ij} is a non-zero-element in row i and column j in a base matrix corresponding to a lifting factor set index corresponding to

15 Z.

[0148] H_2 may be obtained by replacing each zero-element in $H_{BG,EXT}$ with an all zero matrix of size $Z \times Z$ and replacing each non-zero-element with an identity matrix of size $Z \times Z$.

[0149] The encoder may perform encoding and outputting in a plurality of manners. The base graph 30a mentioned in the foregoing embodiments is used as an example for description below. The base graph has a maximum of 42 rows and a maximum of 52 columns, and includes two built-in puncture columns. For ease of description, in the present application, a base graph that has the most rows and of the most columns is referred to as a complete base graph sometimes.

20

[0150] Manner 1

25 [0151] Encoding is performed based on the complete base graph, so that as many parity bits as possible can be obtained. In this case, $m = 42$ and $n = 52$, which correspond to row 0 to row 41 and column 0 to column 51 in the foregoing base graph.

[0152] Correspondingly, for the LDPC matrix H, M is $42 \times Z$, and if the output sequence includes information bits corresponding to the columns corresponding to built-in puncture bits, $N = (42 + Kb) \times Z$; or if the output sequence does not include $2 \times Z$ information bits corresponding to the built-in puncture bits, $N = (40 + Kb) \cdot Z$.

30

[0153] Information bits and parity bits that need to be sent may be determined from the output

sequence generated by the encoder during subsequent processing.

[0154] Manner 2

[0155] Encoding is performed based on some rows and some columns in the complete base graph. Rows and columns may be selected, based on a code rate that needs to be sent, or a quantity of information bits and a quantity of parity bits that need to be sent, or the like, from the complete base graph for encoding.

[0156] For example, the code rate is $2/3$, $m = 7$, and $n = 17$, that is, encoding is performed based on row 0 to row 6 and column 0 to column 16 in the foregoing base graph 30a.

[0157] Correspondingly, for the LDPC matrix H , $M = 7 \times Z$, and if the output sequence includes information bits corresponding to the built-in puncture columns, $N = 17 \times Z$; or if the output sequence does not include the information bits corresponding to the built-in puncture columns, $N = 15 \times Z$.

[0158] For another example, the code rate is $5/6$, $m = 4$, and $n = 14$.

[0159] For another example, the code rate is $1/5$, $m = 42$, and $n = 52$.

[0160] It may be learned that the size of the base graph of H is $4 \leq m \leq 42$ and $14 \leq n \leq 52$. Correspondingly, for the LDPC matrix H , $4 \times Z \leq M \leq 42 \times Z$ and $(4 + Kb) \times Z \leq N \leq (42 + Kb) \times Z$.

[0161] For example, if Z is 13 and in the set 7, encoding is performed on the input sequence by using the LDPC matrix obtained based on the base matrix 3b-7 corresponding to the set 7.

[0162] In another design, an element P_{ij} in row i and column j of the base matrix of the lifting factor Z may also satisfy the following relationship:

$$P_{i,j} = \begin{cases} -1 & V_{i,j} = -1 \\ \text{mod}(V_{i,j}, Z) & V_{i,j} \geq 0 \end{cases}, \text{ where}$$

V_{ij} may be a shift value of an element in row i and column j in a base matrix of a set to which Z belongs, that is, a shift value of a non-zero-element in row i and column j in a base matrix of a maximum lifting factor in the set to which Z belongs.

[0163] For example, using an example in which Z is 13, the element P_{ij} in row i and column j in the base matrix of Z meets:

$$P_{i,j} = \begin{cases} -1 & V_{i,j} = -1 \\ \text{mod}(V_{i,j}, Z) & V_{i,j} \geq 0 \end{cases}, \text{ where}$$

V_{ij} is a shift value of a non-zero-element in row i and column j in the base matrix 3b-7.

[0164] It should be noted that only examples are provided herein, and the examples do not constitute a limitation in the present application.

[0165] In the foregoing implementations, the base matrix H_B of the LDPC matrix H may be any base matrix mentioned in the foregoing embodiments or a base matrix obtained by performing row permutation, or column permutation, or row permutation and column permutation on any base matrix described above. The base graph of the LDPC matrix includes at least a submatrix A and a submatrix B, and may further include a submatrix C, a submatrix D, and a submatrix E. For each submatrix, refer to descriptions in the foregoing embodiments, and details are not described herein again. Certainly, the base matrix H_B may alternatively be a base matrix which base graph is the same as the base graph 30a. The present application is not limited thereto.

[0166] In a possible implementation, the base matrix H_B of the LDPC code may be stored in a memory, and the encoder obtains the LDPC matrix corresponding to the lifting factor Z , to encode the input sequence. In another possible implementation, because there are a plurality of base matrices H_B of the LDPC code, relatively large storage space is occupied when the base matrices are stored according to matrix structures. The base graph of the LDPC code may alternatively be stored in the memory, and shift values of non-zero-elements in the base matrices may be stored row by row or column by column, and then the LDPC matrix may be obtained based on the base graph and shift values of a base matrix corresponding to the lifting factor Z .

[0167] The base graph may indicate positions of non-zero-elements in each base matrix. In another possible implementation, storing the base graph may be storing the positions of the non-zero-elements in the base graph. A position of a non-zero-element may be indicated by a row and a column in which the non-zero-element is located, for example, a column position of a non-zero-element in a row, or a row position of a non-zero-element in a column. In another possible implementation, storing the base graph may also be storing positions of zero-elements in the base graph. Similarly, a position of a zero-element may also be indicated by a row and a column in which the zero-element is located, for example, a column position of a zero-element in a row is located, or a row position of a zero-element in a column. Therefore, positions of non-zero-elements may be obtained by excluding the positions of the zero-elements. It should be noted only examples are provided herein, and the examples do not constitute a limitation in the present application.

[0168] In a design, parameters related to a base graph or a base matrix may be expressed in a table. For example, related parameters or tables may be stored in one or more memories. Related parameters such as a row index in the base graph or the base matrix and a column index in which a non-zero-element is located are read from the memory, so as to obtain the base graph or the base matrix. Optionally, a row weight of each row, and a shift value of a non-zero-element in each row may be stored.

[0169] The following uses FIG. 3a as an example for description. For another base graph or base matrix provided in this application, refer to a similar design.

[0170] For example, parameters in the base graph 30a may be expressed in Table 2.

Table 2

Row index (row index)	Row weight (row degree/row weight)	Column index of non-zero-element (column position of non-zero-element in row)
0	8	0, 1, 2, 3, 6, 9, 10, 11
1	10	0, 3, 4, 5, 6, 7, 8, 9, 11, 12
2	8	0, 1, 3, 4, 8, 10, 12, 13
3	10	1, 2, 4, 5, 6, 7, 8, 9, 10, 13
4	4	0, 1, 11, 14
5	6	0, 1, 5, 7, 11, 15
6	6	0, 5, 7, 9, 11, 16
7	6	1, 5, 7, 11, 13, 17
8	4	0, 1, 12, 18
9	5	1, 8, 10, 11, 19
10	5	0, 1, 6, 7, 20
11	5	0, 7, 9, 13, 21
12	4	1, 3, 11, 22
13	5	0, 1, 8, 13, 23
14	5	1, 6, 11, 13, 24
15	4	0, 10, 11, 25
16	5	1, 9, 11, 12, 26
17	5	1, 5, 11, 12, 27
18	4	0, 6, 7, 28
19	4	0, 1, 10, 29
20	4	1, 4, 11, 30
21	4	0, 8, 13, 31
22	3	1, 2, 32
23	4	0, 3, 5, 33
24	4	1, 2, 9, 34
25	3	0, 5, 35
26	5	2, 7, 12, 13, 36

27	3	0, 6, 37
28	4	1, 2, 5, 38
29	3	0, 4, 39
30	5	2, 5, 7, 9, 40
31	3	1, 13, 41
32	4	0, 5, 12, 42
33	4	2, 7, 10, 43
34	4	0, 12, 13, 44
35	4	1, 5, 11, 45
36	4	0, 2, 7, 46
37	3	10, 13, 47
38	4	1, 5, 11, 48
39	4	0, 7, 12, 49
40	4	2, 10, 13, 50
41	4	1, 5, 11, 51

[0171] It should be noted that only examples are provided herein, and the examples do not constitute a limitation. Related parameters of other base graph or base matrix provided in this application may also be expressed in a similar table. It may be understood that the foregoing base graph 30a and Table 2 are intended to help understand designs of the base graph and the base matrix. Representation forms of the base graph and the base matrix are not limited to only representation forms of the foregoing base graph 30a and Table 2. Other possible variations may be included.

[0172] In an implementation, related parameters may be column index, column weight, and row index in which a non-zero-element is located; or column index, column weight, and row index in which a zero-element is located. Using a form of Table 3 as an example, Table 3 shows only examples of two columns of the base graph. Other columns can be deduced by analogy, and details are not described one by one. Column 14 to column 51 may be weight-1 columns, and may alternatively be not stored. The row index of a non-zero-element is calculated according to a column index.

Table 3

Column index	Column weight	Row index of non-zero-element
0	22	0, 1, 2, 4, 5, 6, 8, 10, 11, 13, 15, 18, 19, 21, 23, 25, 27, 29, 32, 34, 36, 39
1	23	0, 2, 3, 4, 5, 7, 8, 9, 10, 12, 13, 14, 16, 17, 19, 20, 22, 24, 28, 35, 38, 41
...

[0173] In an implementation, the parameter "row weight" or "column weight" in Table 2 or Table 3 may alternatively be omitted. According to columns or rows in which non-zero-elements in a row or a column are located, a quantity of non-zero-elements in a row or a column is learned. Therefore, row weight or column weight is also learned.

[0174] In an implementation, parameter values in "Column index of non-zero-element" in Table 2 and parameter values in "Row index of non-zero-element" in the Table 3 may be sorted in other order instead of an ascending order, provided that a parameter value is indexed to a column of a non-zero-element or indexed to a row of a non-zero-element.

[0175] In an implementation, Table 2 or Table 3 may further include a column "Shift value of non-zero-element". Parameter values in the column "Shift value of non-zero-element" are in a one-to-one correspondence with the parameter values in "Column index of non-zero-element ". Table 5 may further include a column "Shift value of non-zero-element". Parameter values in the column "Shift value of non-zero-element" are in a one-to-one correspondence with parameter values in "Row index of non-zero-element".

[0176] In a design, to save storage space, a position of a non-zero-element in a part with a relatively definite structure in the base graph, may be calculated according to a row position and a column index, and may not be stored. For example, the submatrix E is a diagonal matrix, and includes non-zero-elements only on the diagonal of the matrix. A column index of a non-zero-element may be calculated according to a row index, or a row index of a non-zero-element may also be calculated according to a column index. Using the base graph 30a as an example, for a weight-1 column in row m_e , where $m_e \geq 4$, a column index of a non-zero-element is column $(m_e + K_b)$, in this case, $K_b = 10$. For example, a column index of a non-zero-element in row 4 is column 14. For another example, the bi-diagonal structure B' in the submatrix B is located in row 0 to row 3 and column 11 to column 13 in the base graph 30a. A column position of a non-zero-element may be calculated according to a row index, or a row index of a non-zero-element may also be calculated according to a column index. For row m_B , if $0 < m_B < 3$, column indexes of non-zero-

elements in the row include column $(m_B + K_b)$ and column $(m_B + K_b + 1)$; and if $m_B = 0$ or $m_B = 3$, a column index of a non-zero-element in the row includes column $(m_B + K_b)$.

[0177] As shown in Table 4, Table 4 shows parameters in rows in the base graph 30a. Column indexes of non-zero-elements in column 0 to column 13 may be stored. However, Column indexes of non-zero-elements in column 14 to column 52 are not stored, that is, a column index of a non-zero-element in a weight-1 column is not stored. Table 4 may be used to indicate H_{BG2} including 14 columns:

Table 4

Row index	Row weight	Column index of non-zero-element
0	8	0, 1, 2, 3, 6, 9, 10, 11
1	10	0, 3, 4, 5, 6, 7, 8, 9, 11, 12
2	8	0, 1, 3, 4, 8, 10, 12, 13
3	10	1, 2, 4, 5, 6, 7, 8, 9, 10, 13
4	3	0, 1, 11
5	5	0, 1, 5, 7, 11
6	5	0, 5, 7, 9, 11
7	5	1, 5, 7, 11, 13
8	3	0, 1, 12
9	4	1, 8, 10, 11
10	4	0, 1, 6, 7
11	4	0, 7, 9, 13
12	3	1, 3, 11
13	4	0, 1, 8, 13
14	4	1, 6, 11, 13
15	3	0, 10, 11
16	4	1, 9, 11, 12
17	4	1, 5, 11, 12
18	3	0, 6, 7
19	3	0, 1, 10
20	3	1, 4, 11
21	3	0, 8, 13
22	2	1, 2
23	3	0, 3, 5

24	3	1, 2, 9
25	2	0, 5
26	4	2, 7, 12, 13
27	2	0, 6
28	3	1, 2, 5
29	2	0, 4
30	4	2, 5, 7, 9
31	2	1, 13
32	3	0, 5, 12
33	3	2, 7, 10
34	3	0, 12, 13
35	3	1, 5, 11
36	3	0, 2, 7
37	2	10, 13
38	3	1, 5, 11
39	3	0, 7, 12
40	3	2, 10, 13
41	3	1, 5, 11

[0178] Certainly, for parameters stored in H_{BG2} including 15 columns, parameters of row 0 to row 3 and column 5 to column 41 are the same as those in Table 4. A row weight of row 4 is the row weight of row 4 in Table 4 plus 1, that is, 4. Column positions of non-zero-elements in row 4 include column indexes of non-zero-elements in row 4 in Table 4 and column index 4, that is, 0, 1, 11, and 14. For parameters stored in H_{BG2} including 16 columns, parameters of row 0 to row 3 and column 6 to column 41 are the same as those in Table 4. A row weight of row 4 is the row weight of row 4 in Table 4 plus 1, that is, 4. Column positions of non-zero-elements in row 4 include column indexes of non-zero-elements in row 4 in Table 4 and column index 14, that is, 0, 1, 11, and 14. A row weight of row 5 is the row weight of row 5 in Table 4 plus 1, that is, 6. Column positions of non-zero-elements in row 5 include column positions of non-zero-elements in row 5 in Table 4 and a position whose column index is 15, that is, 0, 1, 5, 7, 11, and 15.

[0179] For parameters stored in H_{BG2} including 17 columns, parameters of row 0 to row 3 and column 7 to column 41 are the same as those in Table 4. A row weight of row 4 is the row weight of row 4 in Table 4 plus 1, that is, 4. Column positions of non-zero-elements in row 4 include column indexes of non-zero-elements in row 4 in Table 4 and column index 14, that is, 0, 1, 11, and 14. A row weight of row 5 is the row weight of row 5 in Table 4 plus 1, that is, 6. Column

positions of non-zero-elements in row 5 include column indexes of non-zero-elements in row 5 in Table 4 and column index 15, that is, 0, 1, 5, 7, 11, and 15. A row weight of row 6 is the row weight of row 6 in Table 4 plus 1, that is, 6. Column positions of non-zero-elements in row 6 include column indexes of non-zero-elements in row 6 in Table 4 and column index 16, that is, 0, 5, 7, 9, 11, and 16, as shown in Table 5.

Table 5

Row index	Row weight	Column index of non-zero-element
0	8	0, 1, 2, 3, 6, 9, 10, 11
1	10	0, 3, 4, 5, 6, 7, 8, 9, 11, 12
2	8	0, 1, 3, 4, 8, 10, 12, 13
3	10	1, 2, 4, 5, 6, 7, 8, 9, 10, 13
4	4	0, 1, 11, 14
5	6	0, 1, 5, 7, 11, 15
6	6	0, 5, 7, 9, 11, 16
7	5	1, 5, 7, 11, 13
8	3	0, 1, 12
9	4	1, 8, 10, 11
10	4	0, 1, 6, 7
11	4	0, 7, 9, 13
12	3	1, 3, 11
13	4	0, 1, 8, 13
14	4	1, 6, 11, 13
15	3	0, 10, 11
16	4	1, 9, 11, 12
17	4	1, 5, 11, 12
18	3	0, 6, 7
19	3	0, 1, 10
20	3	1, 4, 11
21	3	0, 8, 13
22	2	1, 2
23	3	0, 3, 5
24	3	1, 2, 9
25	2	0, 5

26	4	2, 7, 12, 13
27	2	0, 6
28	3	1, 2, 5
29	2	0, 4
30	4	2, 5, 7, 9
31	2	1, 13
32	3	0, 5, 12
33	3	2, 7, 10
34	3	0, 12, 13
35	3	1, 5, 11
36	3	0, 2, 7
37	2	10, 13
38	3	1, 5, 11
39	3	0, 7, 12
40	3	2, 10, 13
41	3	1, 5, 11

[0180] In the foregoing designs, each "Row weight" column is optional. In a possible design, in the base graph, 1 and 0 in each row or each column may be considered as binary digits. Storage space may be saved by storing the binary digits as decimal digits or hexadecimal digits. Using any of the foregoing base graphs as an example, for each row, positions of non-zero-elements in former 26 columns or former 27 columns may be stored by using four hexadecimal digits. For example, if former 14 columns in row 0 are 11110010011100, positions of non-zero-elements in row 0 may be denoted as 0xF2 and 0x70, that is, each eight columns form a hexadecimal digit. For the last two columns in row 0, a corresponding hexadecimal digit may be obtained by filling 0s to reach an integer multiple of 8 bits. Certainly, a corresponding hexadecimal digit may alternatively be obtained by filling 0s before 11110010011100 to reach an integer multiple of 8 bits. Other rows can be deduced by analogy, and details are not described herein again.

[0181] It should be noted that only examples are provided herein, and the examples are not constitute a limitation in the present application.

[0182] When the information bit sequence is encoded, the LDPC matrix H used for encoding may be obtained by expanding the base matrix H_B according to Z. For each non-zero-element $P_{i,j}$ in the base matrix H_B , a circular permutation matrix $h_{i,j}$ of size $Z \times Z$ is determined, where $h_{i,j}$ is a circular permutation matrix obtained by circularly shifting an identity matrix for $P_{i,j}$ times. The parity check matrix H is obtained by replacing each non-zero-element $P_{i,j}$ with $h_{i,j}$ and replacing

each zero-element in the base matrix H_B with an all zero matrix of size $Z \times Z$.

[0183] In a communication system, an LDPC code may be obtained by encoding by using the foregoing method. After obtaining the LDPC code, a communication apparatus may further perform the following one or more operations: performing rate matching on the LDPC code;
5 interleaving, according to an interleaving scheme, an LDPC code obtained by performing rate matching; modulating the interleaved LDPC code according to a modulation scheme to obtain a bit sequence B; and sending the bit sequence B.

[0184] In a decoding method provided in another embodiment of the present application, a decoder decodes an input sequence by using an LDPC matrix. A base graph of the LDPC matrix
10 may be any base graph in the foregoing examples. A base matrix H_B of the LDPC matrix may be any base matrix in the foregoing examples. The input sequence of the decoder may be a soft value sequence of an LDPC code.

[0185] Further, the method includes: determining a lifting factor Z. A communication device at a receive end may receive a signal including the LDPC code, obtain the soft value sequence of
15 the LDPC code in the signal, and determine the corresponding lifting factor Z.

[0186] The decoding, by a decoder, an input sequence by using an LDPC matrix may be decoding the soft value sequence of the LDPC code by using the LDPC matrix corresponding to the lifting factor Z.

[0187] Decoding is an inverse process of encoding. Therefore, for descriptions of the LDPC matrix H and the base graph of the LDPC matrix, refer to the foregoing encoding embodiments.
20 During decoding, decoding may alternatively be performed based on the complete base graph, or based on some rows and columns of the complete base graph. The base matrix H_B of the LDPC matrix may be any base matrix mentioned in the foregoing embodiments or a base matrix obtained by performing row permutation, or column permutation, or both row permutation and column
25 permutation on any base matrix described above. The base graph of the LDPC matrix includes at least a submatrix A and a submatrix B, and may further include a submatrix C, a submatrix D, and a submatrix E. For each part, refer to descriptions in the foregoing embodiments, and details are not described herein again.

[0188] In a possible design, the base matrix H_B of the LDPC code may be stored in a memory,
30 and soft values of the LDPC code may be decoded by obtaining the LDPC matrix corresponding to the lifting factor Z.

[0189] In another possible implementation, because there are a plurality of base matrices of the LDPC code, relatively large storage space is occupied when the base matrices are stored according to matrix structures. The base graph of the LDPC code may alternatively be stored in

the memory, and shift values of non-zero-elements in the base matrices may be stored row by row or column by column, and then the LDPC matrix may be obtained based on the base graph and shift values of the base matrix corresponding to the lifting factor Z .

5 [0190] For a manner of storing the base graph, the base graph may be stored in various manners described in the foregoing encoding embodiments. It should be noted that only examples are provided herein, and the examples do not constitute a limitation.

[0191] Decoding is a process inverse to encoding, and the base matrix H_B used during the decoding has a same characteristic as the base matrix in the encoding method embodiments. For obtaining the LDPC matrix H by lifting the base matrix H_B , refer to the encoding method
10 embodiments.

[0192] In a communication system, before the decoding method, a communication apparatus may further perform the following one or more operations: receiving a signal including an LDPC code, and performing demodulation, deinterleaving, and perform de-rate matching on the signal, to obtain the soft values of the LDPC code.

15 [0193] In a possible implementation, one or more parameters of the following may be stored:

(a) parameter used to obtain any base matrix H_B described in the foregoing implementations. The base matrix H_B may be obtained based on the parameters; for example, the parameters may include one or more of the following: shift values in a base matrix, a lifting factor, a base graph of the base matrix, a code rate, or the like;

20 (b) a base matrix H_B , which is one of any base matrices described in the foregoing implementations;

(c) a matrix obtained after performing lifting based on the base matrix H_B ;

(d) a base matrix obtained by performing row/column permutation based on the any base matrix H_B described in the foregoing implementations, where in this application, the row/column permutation refers to row permutation, column permutation, or row permutation and
25 column permutation; and

(e) a matrix obtained by performing lifting based on the base matrix obtained by performing row/column permutation.

[0194] In a possible implementation, in an encoding process or a decoding process, the
30 encoding an input sequence by using a low density parity check LDPC matrix may be performed in one or more of the following manners:

i. obtaining the base matrix H_B based on the foregoing (a), and performing encoding or decoding based on the obtained base matrix H_B ; or performing row/column permutation based on the obtained base matrix H_B , and performing encoding or decoding based

on a base matrix obtained by performing row/column permutation, where the performing encoding or decoding based on the base matrix may optionally further include performing encoding or decoding based on a lifted matrix of the base matrix;

5 ii. performing encoding or decoding based on the stored base matrix (the stored base matrix H_B , or the stored base matrix obtained by performing row/column permutation based on the base matrix H_B) in (b) or (d); or performing row/column permutation based on the stored base matrix, and performing encoding or decoding based on a base matrix obtained by performing row/column permutation, where the performing encoding or decoding based on the base matrix may optionally further include performing encoding or decoding based on a lifted matrix of the
10 base matrix; and

iii. performing encoding or decoding based on (c) or (e).

[0195] The storing in this application may be storing in one or more memories. The one or more memories may be separately disposed, or may be integrated into the encoder, the decoder, a processor, a chip, a communication apparatus, or a terminal. Alternatively, some of the one or
15 more memories may be separately disposed, and the others are integrated into an encoder, a decoder, a processor, a chip, a communication apparatus, or a terminal. A type of the memory may be a storage medium in any form. This is not limited in this application.

[0196] FIG. 5 is a schematic structural diagram of a communication apparatus 500. The apparatus 500 may be configured to implement the method described in the foregoing method
20 embodiments. Reference may be made to descriptions in the foregoing method embodiments. The communication apparatus 500 may be a chip, a base station, a terminal, or other network devices.

[0197] The communication apparatus 500 includes one or more processors 501. The processor 501 may be a general-purpose processor, a special-purpose processor, or the like. For example, the processor 501 may be a baseband processor or a central processing unit. The baseband
25 processor may be configured to process a communication protocol and communication data. The central processing unit may be configured to: control the communication apparatus (such as a base station, a terminal, or a chip), execute a software program, and process data of the software program.

[0198] In a possible design, the communication apparatus 500 includes one or more
30 processors 501. The one or more processors 501 may implement a function of the foregoing encoder. In another possible design, the foregoing encoder may be a part of the processor 501. In addition to the function of the encoder, the processor 501 may further implement another function.

[0199] The communication apparatus 500 encodes an input sequence by using an LDPC matrix. A base graph of the LDPC matrix may be any base graph in the foregoing examples, or a

base graph obtained by performing row permutation, column permutation, or both row permutation and column permutation on any base graph described above. A base matrix H_B of the LDPC matrix may be any base matrix in the foregoing embodiments, or a base matrix obtained by performing row permutation, column permutation, or both row permutation and column permutation on any base matrix described above. The input sequence of the encoder may be an information bit sequence.

[0200] In a possible design, the one or more processors 501 may implement a function of the foregoing decoder. In another possible design, the foregoing decoder may be a part of the processor 501.

[0201] The communication apparatus 500 may be configured to decode an input sequence by using an LDPC matrix. A base graph of the LDPC matrix may be any base graph in the foregoing examples, or a base graph obtained by performing row permutation, column permutation, or both row permutation and column permutation on any base graph described above. A base matrix H_B of the LDPC matrix may be any base matrix in the foregoing examples, or a base matrix obtained by performing row permutation, column permutation, or both row permutation and column permutation on any base matrix described above. The input sequence of the decoder may be a soft value sequence.

[0202] In an optional possible design, the processor 501 may further include instruction(s) 503. The instruction(s) may be executed on the processor, so that the communication apparatus 500 performs the method described in the foregoing method embodiments.

[0203] In another possible design, the communication apparatus 500 may further include a circuit. The circuit may implement the function of the encoder, the function of the decoder, or the functions of the encoder and the decoder in the foregoing method embodiments.

[0204] Optionally, the communication apparatus 500 may include one or more memories 502. The memory stores instruction(s) 504, and the instruction(s) may be executed on the processor, so that the communication apparatus 500 performs the method described in the foregoing method embodiments. Optionally, the memory may further store data. Optionally, the processor may further store instruction(s) and/or data. The processor and the memory may be separately disposed, or may be integrated together. Optionally, the one or more memories 502 may store parameters related to a base matrix, for example, a shift value, a base graph, a matrix obtained through lifting based on the base graph, each row in the base matrix, and a lifting factor. Optionally, the one or more memories 502 may store a base matrix or a matrix obtained through lifting based on the base matrix.

[0205] Optionally, the communication apparatus 500 may further include a transceiver 505

and an antenna 506. The processor 501 may be referred to as a processing unit. The processor 501 controls the communication apparatus (a terminal or a base station). The transceiver 505 may be referred to as a transceiver unit, a transceiver circuit, a transceiver, or the like, and is configured to implement transmitting and receiving functions of the communication apparatus by using the antenna 506.

5

[0206] Optionally, the communication apparatus 500 may further include a component configured to generate a transport block CRC, a component used for code block segmentation and CRC attachment, an interleaver used for interleaving, a modulator used for modulation processing, or the like. Functions of the components may be implemented by using the one or more processors 501.

10

[0207] Optionally, the communication apparatus 500 may further include a demodulator used for a demodulation operation, a deinterleaver used for deinterleaving, a component used for de-rate matching, or the like. Functions of the components may be implemented by using the one or more processors 501.

15

[0208] FIG. 6 is a schematic diagram of a communication system 600. The communication system 600 includes a communication device 60 and a communication device 61. Information data is received and sent between the communication device 60 and the communication device 61. The communication device 60 and the communication device 61 may be the communication apparatus 500, or the communication device 60 and the communications device 61 respectively includes a communication apparatus 500 for receiving and sending the information data. In an example, the communication device 60 may be a terminal, and correspondingly, the communication device 61 may be a base station. In another example, the communication device 60 is a base station, and correspondingly, the communication device 61 may be a terminal.

20

[0209] A person skilled in the art may further understand that various illustrative logical blocks (illustrative logic block) and steps (step) that are listed in the embodiments of the present application may be implemented by using electronic hardware, computer software, or a combination thereof. Whether the functions are implemented by using hardware or software depends on particular applications and a design requirement of the complete system. For each specific application, a person skilled in the art may use various methods to implement the functions. However, this implementation should not be understood to go beyond the protection scope of the embodiments of the present application.

25

30

[0210] The various illustrative logical units and circuits described in the embodiments of the present application may implement or operate the described functions by using a general processor, a digital signal processor, an application-specific integrated circuit (ASIC), a field programmable

gate array (FPGA) or another programmable logical apparatus, a discrete gate or transistor logic, a discrete hardware component, or a design of any combination thereof. The general processor may be a microprocessor. Optionally, the general processor may also be any conventional processor, controller, microcontroller, or state machine. The processor may also be implemented
5 by a combination of computing apparatuses, such as a digital signal processor and a microprocessor, multiple microprocessors, one or more microprocessors with a digital signal processor core, or any other similar configuration.

[0211] Steps of the methods or algorithms described in the embodiments of the present application may be directly embedded into hardware, instruction(s) executed by a processor, or a
10 combination thereof. The memory may be a RAM memory, a flash memory, a ROM memory, an EPROM memory, an EEPROM memory, a register, a hard disk, a removable magnetic disk, a CD-ROM, or a storage medium of any other form in the art. For example, the memory may connect to a processor so that the processor may read information from the memory and write information to the memory. Alternatively, the memory may further be integrated into a processor. The
15 processor and the memory may be disposed in an ASIC, and the ASIC may be disposed in UE. Alternatively, the processor and the memory may be disposed in different components of UE.

[0212] With descriptions of the foregoing embodiments, a person skilled in the art may clearly understand that the present application may be implemented by hardware, firmware or a
20 combination thereof. When the present application is implemented by using a software program, all or a part of the present application may be implemented in a form of a computer program product. The computer program product includes one or more computer instructions. When the computer instructions are loaded and executed on the computer, the procedures or functions according to the embodiments of the present application are all or partially generated. When the present application is implemented by the software program, the foregoing functions may be
25 stored in a computer-readable medium or transmitted as one or more instructions or code in the computer-readable medium. The computer may be a general-purpose computer, a dedicated computer, a computer network, or another programmable apparatus. The computer instructions may be stored in a computer-readable storage medium or may be transmitted from a computer-readable storage medium to another computer-readable storage medium. The computer-readable
30 medium includes a computer storage medium and a communication medium, where the communication medium includes any medium that enables a computer program to be transmitted from one place to another. The storage medium may be any available medium accessible to a computer. The following provides an example but does not impose a limitation: The computer-readable medium may include a RAM, a ROM, an EEPROM, a CD-ROM, or another optical disc

storage or disk storage medium, or another magnetic storage device, or any other medium that can carry or store expected program code in a form of instruction(s) or a data structure and can be accessed by a computer. In addition, any connection may be appropriately defined as a computer-readable medium. For example, if software is transmitted from a website, a server or another remote source by using a coaxial cable, an optical fiber/cable, a twisted pair, a digital subscriber line (DSL) or wireless technologies such as infrared ray, radio and microwave, the coaxial cable, optical fiber/cable, twisted pair, DSL or wireless technologies such as infrared ray, radio and microwave are included in fixation of a medium to which they belong. For example, a disk (Disk) and disc (disc) used by the present application includes a compact disc (CD), a laser disc, an optical disc, a digital versatile disc (DVD), a floppy disk and a Blue-ray disc, where the disk generally copies data by a magnetic means, and the disc copies data optically by a laser means. The foregoing combination should also be included in the protection scope of the computer-readable medium.

[0213] In conclusion, what is described above is merely examples of embodiments of the technical solutions of the present application, but is not intended to limit the protection scope of the present application. Any modification, equivalent replacement, or improvement made without departing from the principle of the present application shall fall within the protection scope of the present application.

CLAIMS

What is claimed is:

1. An encoding method, wherein the method comprises:

encoding an input sequence by using a low-density parity-check LDPC matrix, wherein the LDPC matrix is obtained based on a base graph, and the base graph comprises a submatrix A, a submatrix B, a submatrix C, a submatrix D, and a submatrix E, wherein

the submatrix A is a matrix comprising m_A rows and n_A columns, m_A and n_A are positive integers, $4 \leq m_A \leq 7$, and $n_A = 10$;

the submatrix B is a matrix comprising m_A rows and m_A columns, and the submatrix B comprises a column whose weight is 3 and a submatrix B' having a bi-diagonal structure;

the submatrix D comprises m_D rows in a matrix F, the matrix F is a matrix comprising m_F rows and $(m_A + n_A)$ columns, m_D and m_F are positive integers, $0 \leq m_D \leq m_F$, and $35 \leq m_F \leq 38$;

the submatrix C is an all zero matrix comprising m_A rows and m_D columns; and

the submatrix E is an identity matrix comprising m_D rows and m_D columns, wherein in the matrix F, weights of nine rows are 3, and a weight of one row is 2.

2. A decoding method, wherein the method comprises:

decoding an input sequence by using a low density parity check LDPC matrix, wherein the LDPC matrix is obtained based on a base graph, and the base graph comprises a submatrix A, a submatrix B, a submatrix C, a submatrix D, and a submatrix E, wherein

the submatrix A is a matrix comprising m_A rows and n_A columns, m_A and n_A are positive integers, $4 \leq m_A \leq 7$, and $n_A = 10$;

the submatrix B is a matrix comprising m_A rows and m_A columns, and the submatrix B comprises a column whose weight is 3 and a submatrix B' having a double diagonal structure;

the submatrix D comprises m_D rows in a matrix F, the matrix F is a matrix comprising m_F rows and $(m_A + n_A)$ columns, m_D and m_F are positive integers, $0 \leq m_D \leq m_F$, and $35 \leq m_F \leq 38$;

the submatrix C is an all zero matrix comprising m_A rows and m_D columns; and

the submatrix E is an identity matrix comprising m_D rows and m_D columns, wherein in the matrix F, weights of nine rows are 3, and a weight of one row is 2.

3. The method according to claim 1 or 2, wherein in the matrix F, a weight of one column is 16, a weight of one column is 18, a weight of one column is 11, weights of two columns are 10, a weight of one column is 9, a weight of one column is 8, a weight of one column is 7, a weight of

one column is 6, weights of two columns are 4, a weight of one column is 3, and weights of two columns are 2.

4. The method according to claim 3, wherein if $m_A > 4$, a weight of other columns in the matrix F is 0.

5. An encoding method, wherein the method comprises:

encoding an input sequence by using a low density parity check LDPC matrix, wherein the LDPC matrix is obtained based on a base graph, and the base graph comprises a submatrix A, a submatrix B, a submatrix C, a submatrix D, and a submatrix E, wherein

the submatrix A is a matrix comprising m_A rows and n_A columns, m_A and n_A are positive integers, $4 \leq m_A \leq 7$, and $n_A=10$;

the submatrix B is a matrix comprising m_A rows and m_A columns, and the submatrix B comprises a column whose weight is 3 and a submatrix B' having a double diagonal structure;

the submatrix D comprises m_D rows in a matrix F, the matrix F is a matrix comprising m_F rows and $(m_A + n_A)$ columns, m_D and m_F are positive integers, $0 \leq m_D \leq m_F$, and $35 \leq m_F \leq 38$;

the submatrix C is an all zero matrix comprising m_A rows and m_D columns; and

the submatrix E is an identity matrix comprising m_D rows and m_D columns, wherein

in the matrix F, a weight of one column is 16, a weight of one column is 18, a weight of one column is 11, weights of two columns are 10, a weight of one column is 9, a weight of one column is 8, a weight of one column is 7, a weight of one column is 6, weights of two columns are 4, a weight of one column is 3, and weights of two columns are 2.

6. A decoding method, wherein the method comprises:

decoding an input sequence by using a low density parity check LDPC matrix, wherein

the LDPC matrix is obtained based on a base graph, and the base graph comprises a submatrix A, a submatrix B, a submatrix C, a submatrix D, and a submatrix E, wherein

the submatrix A is a matrix comprising m_A rows and n_A columns, m_A and n_A are positive integers, $4 \leq m_A \leq 7$, and $n_A=10$;

the submatrix B is a matrix comprising m_A rows and m_A columns, and the submatrix B comprises a column whose weight is 3 and a submatrix B' having a bi-diagonal structure;

the submatrix D comprises m_D rows in a matrix F, the matrix F is a matrix comprising m_F rows and $(m_A + n_A)$ columns, m_D and m_F are positive integers, $0 \leq m_D \leq m_F$, and $35 \leq m_F \leq 38$;

the submatrix C is an all zero matrix comprising m_A rows and m_D columns; and

the submatrix E is an identity matrix comprising m_D rows and m_D columns, wherein

in the matrix F, a weight of one column is 16, a weight of one column is 18, a weight of one column is 11, weights of two columns are 10, a weight of one column is 9, a weight of one column is 8, a weight of one column is 7, a weight of one column is 6, weights of two columns are 4, a weight of one column is 3, and weights of two columns are 2.

7. The method according to claim 5 or 6, wherein if $m_A > 4$, a weight of a remaining column in the matrix F is 0.

8. The method according to any one of claims 5 to 7, wherein in the matrix F, in 10 rows having an orthogonal structure, weights of nine rows are 3, and a weight of one row is 2.

9. The method according to any one of claims 1 to 8, wherein the matrix F comprises at least 10 rows, and any two adjacent rows in the at least 10 rows are orthogonal.

10. The method according to any one of claims 1 to 9, wherein the matrix F comprises at least five groups, each of the at least five groups comprises at least two rows, the at least two rows are orthogonal, and optionally, the at least two rows are consecutive rows.

11. The method according to claim 9 or 10, wherein in 10 rows in the matrix F, 14 columns in one row of said 10 rows in the matrix F are:

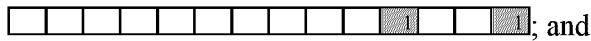

14 columns in each of the remaining nine rows are one of the following:

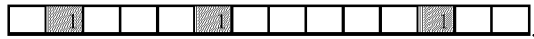
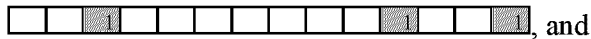
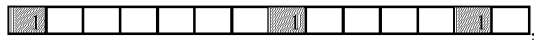
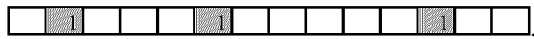
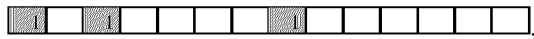
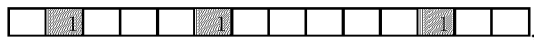
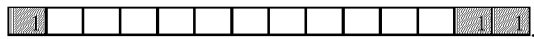
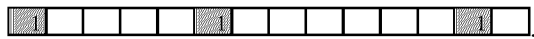

12. The method according to claim 11, wherein the 14 columns in the 10 rows in the matrix F comprise the following rows or columns:

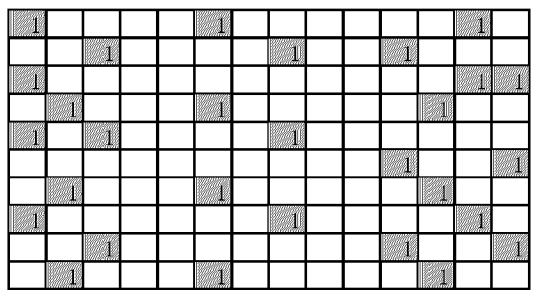

13. The method according to claim 12, wherein if $m_A = 7$, weights of rows in the matrix F are respectively:

5, 3, 4, 4, 4, 3, 4, 4, 3, 4, 4, 3, 3, 3, 3, 2, 3, 3, 2, 4, 2, 3, 2, 4, 2, 3, 3, 3, 3, 3, 2, 3, 3, 3, and 3.

14. The method according to claim 13, wherein the 14 columns in the matrix F comprise the following rows or columns:

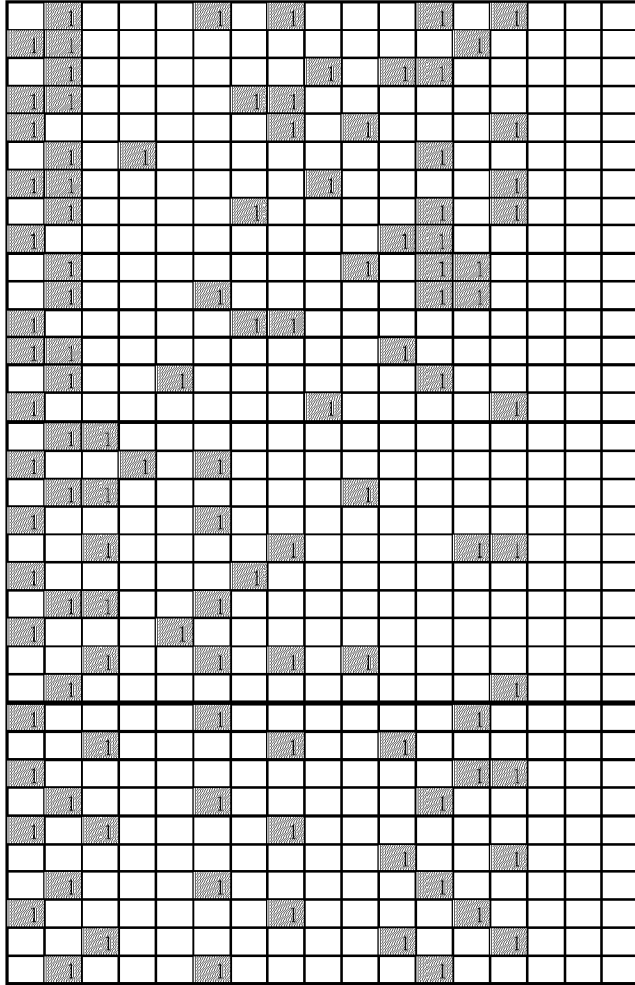

15. The method according to claim 14, wherein $m_A + m_D = 42$, and the base graph comprises rows or columns shown in a base graph 30a.

16. The method according to any one of claims 1 to 15, wherein the LDPC matrix is obtained based on a permuted base graph obtained by performing row permutation, column permutation, or row permutation and column permutation on the base graph.

17. An information processing method, comprising:

encoding an input sequence $c = \{c_0, c_1, c_2, \dots, c_{K-1}\}$ to obtain an output sequence $d = \{d_0, d_1, d_2, \dots, d_{N-1}\}$, wherein K and N are integers greater than 0;

wherein the output sequence d comprises K_0 bits in the input sequence c and parity bits in a

parity bit check sequence w , K_0 is an integer, and $0 < K_0 \leq K$; and

the parity bit sequence w and the input sequence c satisfy a formula $H \times \begin{bmatrix} c^T \\ w^T \end{bmatrix} = 0^T$, wherein $c^T = [c_0, c_1, c_2, \dots, c_{K-1}]^T$ is a transposed vector of a vector including bits in the input sequence c ; and $w^T = [w_0, w_1, w_2, \dots, w_{N-K_0-1}]^T$ is a transposed vector of a vector including bits in the parity bit sequence w , wherein 0^T is a column vector, and values of all elements of the column vector are 0; and

H is a low density parity check LDPC matrix, a base graph of H comprises H_{BG} and $H_{BG,EXT}$,

wherein $H_{BG,EXT} = \begin{bmatrix} \mathbf{0}_{m_c \times n_c} \\ I_{n_c \times n_c} \end{bmatrix}$, $\mathbf{0}_{m_c \times n_c}$ indicates an $m_c \times n_c$ zero matrix, $I_{n_c \times n_c}$ indicates an $n_c \times n_c$ identity matrix, H_{BG} comprises columns corresponding to K_b columns corresponding to information bit in H_{BG2} , and comprises column 10 to column $(10 + m_A - 1)$ in H_{BG2} , a quantity of columns in H_{BG2} is $10 + m_A$, $4 \leq m_A \leq 7$, and $K_b \in \{6, 8, 9, 10\}$, wherein

$m_c = 7$, $0 \leq n_c \leq 35$, and the quantity of columns in H_{BG2} is equal to 17;

$m_c = 6$, $0 \leq n_c \leq 36$, and the quantity of columns in H_{BG2} is equal to 16;

$m_c = 5$, $0 \leq n_c \leq 37$, and the quantity of columns in H_{BG2} is equal to 15; or

$m_c = 4$, $0 \leq n_c \leq 38$, and the quantity of columns in H_{BG2} is equal to 14.

18. The method according to claim 17, wherein

if the quantity of columns in H_{BG2} is equal to 17, column indexes of non-zero-elements in each row are shown in Table 5.

19. The method according to claim 17, wherein

if the quantity of columns in H_{BG2} is equal to 14, column indexes of non-zero-elements in each row are shown in Table 4.

20. An encoding method, comprising:

encoding an input sequence using a matrix H , to obtain an encoded sequence;

wherein the matrix H is determined according to a base matrix and a lifting factor Z , Z is a positive integer;

wherein the base matrix comprises a plurality of rows and columns of a matrix H_B ;

wherein an element in the matrix H_B is either a zero-element or non-zero-element;

the matrix H_B comprises following rows with non-zero-elements, wherein row indexes (i), column indexes (j) of the non-zero-elements are as follows:

$i = 0, j = 0, 1, 2, 3, 6, 9, 10, 11$;

$i = 1, j = 0, 3, 4, 5, 6, 7, 8, 9, 11, 12;$
 $i = 2, j = 0, 1, 3, 4, 8, 10, 12, 13;$
 $i = 3, j = 1, 2, 4, 5, 6, 7, 8, 9, 10, 13;$
 $i = 4, j = 0, 1, 11, 14;$
 $i = 5, j = 0, 1, 5, 7, 11, 15;$
 $i = 6, j = 0, 5, 7, 9, 11, 16;$
 $i = 7, j = 1, 5, 7, 11, 13, 17;$
 $i = 8, j = 0, 1, 12, 18;$
 $i = 9, j = 1, 8, 10, 11, 19;$
 $i = 10, j = 0, 1, 6, 7, 20;$
 $i = 11, j = 0, 7, 9, 13, 21;$
 $i = 12, j = 1, 3, 11, 22;$
 $i = 13, j = 0, 1, 8, 13, 23;$
 $i = 14, j = 1, 6, 11, 13, 24;$
 $i = 15, j = 0, 10, 11, 25;$
 $i = 16, j = 1, 9, 11, 12, 26;$
 $i = 17, j = 1, 5, 11, 12, 27;$
 $i = 18, j = 0, 6, 7, 28;$
 $i = 19, j = 0, 1, 10, 29;$
 $i = 20, j = 1, 4, 11, 30;$
 $i = 21, j = 0, 8, 13, 31;$
 $i = 22, j = 1, 2, 32;$
 $i = 23, j = 0, 3, 5, 33;$
 $i = 24, j = 1, 2, 9, 34;$
 $i = 25, j = 0, 5, 35;$
 $i = 26, j = 2, 7, 12, 13, 36;$
 $i = 27, j = 0, 6, 37;$
 $i = 28, j = 1, 2, 5, 38;$
 $i = 29, j = 0, 4, 39;$
 $i = 30, j = 2, 5, 7, 9, 40;$
 $i = 31, j = 1, 13, 41;$
 $i = 32, j = 0, 5, 12, 42;$
 $i = 33, j = 2, 7, 10, 43;$
 $i = 34, j = 0, 12, 13, 44;$

$i = 35, j = 1, 5, 11, 45;$
 $i = 36, j = 0, 2, 7, 46;$
 $i = 37, j = 10, 13, 47;$
 $i = 38, j = 1, 5, 11, 48;$
 $i = 39, j = 0, 7, 12, 49;$
 $i = 40, j = 2, 10, 13, 50;$
 $i = 41, j = 1, 5, 11, 51.$

21. An encoding method, comprising:

encoding an input sequence using a matrix H, to obtain an encoded sequence;

wherein the matrix H is determined according to a base matrix and a lifting factor Z, Z is a positive integer;

wherein the base matrix comprises m rows and n columns, and elements in the base matrix are respectively represented by their row index i and column index j, where $0 \leq i < m$, $0 \leq j < n$;

wherein an element in the base matrix is either a zero-element or non-zero-element;

the base matrix comprises one or more following rows with non-zero-elements, wherein row indexes (i), column indexes (j) of the non-zero-elements are as follows:

$i = 32, j = 0, 5, 12, 42;$
 $i = 33, j = 2, 7, 10, 43;$
 $i = 34, j = 0, 12, 13, 44;$
 $i = 35, j = 1, 5, 11, 45;$
 $i = 36, j = 0, 2, 7, 46;$
 $i = 37, j = 10, 13, 47;$
 $i = 38, j = 1, 5, 11, 48;$
 $i = 39, j = 0, 7, 12, 49;$
 $i = 40, j = 2, 10, 13, 50;$
 $i = 41, j = 1, 5, 11, 51.$

22. The method according to claim 21, wherein the base matrix further comprises one or more following rows with non-zero-elements, wherein row indexes (i), column indexes (j) of the non-zero-elements are as follows:

$i = 0, j = 0, 1, 2, 3, 6, 9, 10, 11;$
 $i = 1, j = 0, 3, 4, 5, 6, 7, 8, 9, 11, 12;$
 $i = 2, j = 0, 1, 3, 4, 8, 10, 12, 13;$
 $i = 3, j = 1, 2, 4, 5, 6, 7, 8, 9, 10, 13;$
 $i = 4, j = 0, 1, 11, 14;$

$i = 5, j = 0, 1, 5, 7, 11, 15;$
 $i = 6, j = 0, 5, 7, 9, 11, 16;$
 $i = 7, j = 1, 5, 7, 11, 13, 17;$
 $i = 8, j = 0, 1, 12, 18;$
 $i = 9, j = 1, 8, 10, 11, 19;$
 $i = 10, j = 0, 1, 6, 7, 20;$
 $i = 11, j = 0, 7, 9, 13, 21;$
 $i = 12, j = 1, 3, 11, 22;$
 $i = 13, j = 0, 1, 8, 13, 23;$
 $i = 14, j = 1, 6, 11, 13, 24;$
 $i = 15, j = 0, 10, 11, 25;$
 $i = 16, j = 1, 9, 11, 12, 26;$
 $i = 17, j = 1, 5, 11, 12, 27;$
 $i = 18, j = 0, 6, 7, 28;$
 $i = 19, j = 0, 1, 10, 29;$
 $i = 20, j = 1, 4, 11, 30;$
 $i = 21, j = 0, 8, 13, 31;$
 $i = 22, j = 1, 2, 32;$
 $i = 23, j = 0, 3, 5, 33;$
 $i = 24, j = 1, 2, 9, 34;$
 $i = 25, j = 0, 5, 35;$
 $i = 26, j = 2, 7, 12, 13, 36;$
 $i = 27, j = 0, 6, 37;$
 $i = 28, j = 1, 2, 5, 38;$
 $i = 29, j = 0, 4, 39;$
 $i = 30, j = 2, 5, 7, 9, 40;$
 $i = 31, j = 1, 13, 41.$

23. The method according to any one of claims 20 to 22, wherein the input sequence is represented as $c = \{c_0, c_1, c_2, \dots, c_{K-1}\}$, the encoded sequence is represented as $d = \{d_0, d_1, d_2, \dots, d_{N-1}\}$, wherein N is a positive integer, $N = (40+Kb) \times Z$, and Kb is one of $\{6, 8, 9, 10\}$.

24. The method according to claim 23, wherein the encoded sequence d comprises K_0 bits in the input sequence c and $N-K_0$ parity bits in a parity sequence $w = \{w_0, w_1, w_2, \dots, w_{N-K_0-1}\}$, K_0 is an integer greater than 0 and less than or equal to K,

wherein the matrix H, the parity sequence w and the input sequence c meet:

$$H \times \begin{bmatrix} c^T \\ w^T \end{bmatrix} = 0^T,$$

wherein $c^T = [c_0, c_1, c_2, \dots, c_{K-1}]^T$, $w^T = [w_0, w_1, w_2, \dots, w_{N-K-1}]^T$, 0^T is a column vector, and values of all elements of 0^T are 0.

25. The method according to claim 24, wherein $K_0 = K - 2 \times Z$.

26. A decoding method, wherein the method comprises:

decoding an input sequence using a matrix H, to obtain a decoded sequence;

wherein the matrix H is determined according to a base matrix and a lifting factor Z, Z is a positive integer;

wherein the base matrix comprises a plurality of rows and columns of a matrix H_B ;

wherein an element in the matrix H_B is either a zero-element or non-zero-element;

the matrix H_B comprises following rows with non-zero-elements, wherein row indexes (i), column indexes (j) of the non-zero-elements are as follows:

$i = 0, j = 0, 1, 2, 3, 6, 9, 10, 11$;

$i = 1, j = 0, 3, 4, 5, 6, 7, 8, 9, 11, 12$;

$i = 2, j = 0, 1, 3, 4, 8, 10, 12, 13$;

$i = 3, j = 1, 2, 4, 5, 6, 7, 8, 9, 10, 13$;

$i = 4, j = 0, 1, 11, 14$;

$i = 5, j = 0, 1, 5, 7, 11, 15$;

$i = 6, j = 0, 5, 7, 9, 11, 16$;

$i = 7, j = 1, 5, 7, 11, 13, 17$;

$i = 8, j = 0, 1, 12, 18$;

$i = 9, j = 1, 8, 10, 11, 19$;

$i = 10, j = 0, 1, 6, 7, 20$;

$i = 11, j = 0, 7, 9, 13, 21$;

$i = 12, j = 1, 3, 11, 22$;

$i = 13, j = 0, 1, 8, 13, 23$;

$i = 14, j = 1, 6, 11, 13, 24$;

$i = 15, j = 0, 10, 11, 25$;

$i = 16, j = 1, 9, 11, 12, 26$;

$i = 17, j = 1, 5, 11, 12, 27$;

$i = 18, j = 0, 6, 7, 28$;

$i = 19, j = 0, 1, 10, 29$;

$i = 20, j = 1, 4, 11, 30$;

$i = 21, j = 0, 8, 13, 31;$
 $i = 22, j = 1, 2, 32;$
 $i = 23, j = 0, 3, 5, 33;$
 $i = 24, j = 1, 2, 9, 34;$
 $i = 25, j = 0, 5, 35;$
 $i = 26, j = 2, 7, 12, 13, 36;$
 $i = 27, j = 0, 6, 37;$
 $i = 28, j = 1, 2, 5, 38;$
 $i = 29, j = 0, 4, 39;$
 $i = 30, j = 2, 5, 7, 9, 40;$
 $i = 31, j = 1, 13, 41;$
 $i = 32, j = 0, 5, 12, 42;$
 $i = 33, j = 2, 7, 10, 43;$
 $i = 34, j = 0, 12, 13, 44;$
 $i = 35, j = 1, 5, 11, 45;$
 $i = 36, j = 0, 2, 7, 46;$
 $i = 37, j = 10, 13, 47;$
 $i = 38, j = 1, 5, 11, 48;$
 $i = 39, j = 0, 7, 12, 49;$
 $i = 40, j = 2, 10, 13, 50;$
 $i = 41, j = 1, 5, 11, 51.$

27. A decoding method, wherein the method comprises:

decoding an input sequence using a matrix H, to obtain a decoded sequence;

wherein the matrix H is determined according to a base matrix and a lifting factor Z, Z is a positive integer;

wherein the base matrix comprises m rows and n columns, and elements in the base matrix are respectively represented by their row index i and column index j, where $0 \leq i < m$, $0 \leq j < n$;

wherein an element in the base matrix is either a zero-element or non-zero-element;

the base matrix comprises one or more following rows with non-zero-elements, wherein row indexes (i), column indexes (j) of the non-zero-elements are as follows:

$i = 32, j = 0, 5, 12, 42;$
 $i = 33, j = 2, 7, 10, 43;$
 $i = 34, j = 0, 12, 13, 44;$
 $i = 35, j = 1, 5, 11, 45;$

$i = 36, j = 0, 2, 7, 46;$
 $i = 37, j = 10, 13, 47;$
 $i = 38, j = 1, 5, 11, 48;$
 $i = 39, j = 0, 7, 12, 49;$
 $i = 40, j = 2, 10, 13, 50;$
 $i = 41, j = 1, 5, 11, 51.$

28. The method according to claim 27, wherein the base matrix further comprises one or more following rows with non-zero-elements, wherein row indexes (i), column indexes (j) of the non-zero-elements are as follows:

$i = 0, j = 0, 1, 2, 3, 6, 9, 10, 11;$
 $i = 1, j = 0, 3, 4, 5, 6, 7, 8, 9, 11, 12;$
 $i = 2, j = 0, 1, 3, 4, 8, 10, 12, 13;$
 $i = 3, j = 1, 2, 4, 5, 6, 7, 8, 9, 10, 13;$
 $i = 4, j = 0, 1, 11, 14;$
 $i = 5, j = 0, 1, 5, 7, 11, 15;$
 $i = 6, j = 0, 5, 7, 9, 11, 16;$
 $i = 7, j = 1, 5, 7, 11, 13, 17;$
 $i = 8, j = 0, 1, 12, 18;$
 $i = 9, j = 1, 8, 10, 11, 19;$
 $i = 10, j = 0, 1, 6, 7, 20;$
 $i = 11, j = 0, 7, 9, 13, 21;$
 $i = 12, j = 1, 3, 11, 22;$
 $i = 13, j = 0, 1, 8, 13, 23;$
 $i = 14, j = 1, 6, 11, 13, 24;$
 $i = 15, j = 0, 10, 11, 25;$
 $i = 16, j = 1, 9, 11, 12, 26;$
 $i = 17, j = 1, 5, 11, 12, 27;$
 $i = 18, j = 0, 6, 7, 28;$
 $i = 19, j = 0, 1, 10, 29;$
 $i = 20, j = 1, 4, 11, 30;$
 $i = 21, j = 0, 8, 13, 31;$
 $i = 22, j = 1, 2, 32;$
 $i = 23, j = 0, 3, 5, 33;$
 $i = 24, j = 1, 2, 9, 34;$

$i = 25, j = 0, 5, 35;$
 $i = 26, j = 2, 7, 12, 13, 36;$
 $i = 27, j = 0, 6, 37;$
 $i = 28, j = 1, 2, 5, 38;$
 $i = 29, j = 0, 4, 39;$
 $i = 30, j = 2, 5, 7, 9, 40;$
 $i = 31, j = 1, 13, 41.$

29. The method according to any one of claims 20 to 28, wherein each zero-element corresponds to an all-zero matrix of size $Z \times Z$ in the matrix H,

wherein each non-zero-element in row i and column j has a value $V_{i,j}$ and corresponds to a circular permutation matrix $I(P_{i,j})$ of size $Z \times Z$ in the matrix H,

wherein $P_{i,j}$ is an integer shift value greater than or equal to zero, and $P_{i,j} = \text{mod}(V_{i,j}, Z)$.

30. The method according to any one of claims 20 to 29, wherein the lifting factor Z is a minimum of a plurality of lifting factors satisfying a relationship of $10 \times Z = K$.

31. The method according to any one of claims 20 to 30, wherein the lifting factor Z satisfies $Z = a \times 2^j$, where $a \in \{2, 3, 5, 7, 9, 11, 13, 15\}$, and

wherein:

in case of $a = 2, j = 0, 1, 2, 3, 4, 5, 6$ or $7;$

in case of $a = 3, j = 0, 1, 2, 3, 4, 5, 6$ or $7;$

in case of $a = 5, j = 0, 1, 2, 3, 4, 5$ or $6;$

in case of $a = 7, j = 0, 1, 2, 3, 4$ or $5;$

in case of $a = 9, j = 0, 1, 2, 3, 4$ or $5;$

in case of $a = 11, j = 0, 1, 2, 3, 4$ or $5;$

in case of $a = 13, j = 0, 1, 2, 3$ or $4;$ or

in case of $a = 15, j = 0, 1, 2, 3$ or $4.$

32. The method according to any one of claims 20 to 31, wherein the lifting factor $Z = Z_0, Z_0$ is a minimum of a plurality of lifting factors satisfying a relationship of $Kb \times Z_0 \geq K$, and Kb is one of $\{6, 8, 9, 10\}$.

33. The method according to claim 32, wherein

in case of $K > 640, Kb$ equals to $10;$ or

in case of $K > 560$ and $K \leq 640, Kb$ equals to $9;$ or

in case of $K > 192$ and $K \leq 560, Kb$ equals to $8;$ or

in case of $K \leq 192, Kb$ equals to $6.$

34. The method according to any one of claims 20 to 33, wherein the matrix H is determined

according to a permuted matrix of the base matrix, and wherein the permuted matrix is obtained by performing row permutation, or column permutation, or row permutation and column permutation on the base matrix.

35. An apparatus, comprising:

one or more memories configured to store program instructions; and

one or more processors coupled to the one or more memories and configured to execute the program instructions to cause the apparatus to:

encode an input sequence using a matrix H , to obtain an encoded sequence;

wherein the matrix H is determined according to a base matrix and a lifting factor Z , Z is a positive integer;

wherein the base matrix comprises a plurality of rows and columns of a matrix H_B ;

wherein an element in the matrix H_B is either a zero-element or non-zero element;

the matrix H_B comprises following rows with non-zero-elements, wherein row indexes (i), column indexes (j) of the non-zero-elements are as follows:

$i = 0, j = 0, 1, 2, 3, 6, 9, 10, 11$;

$i = 1, j = 0, 3, 4, 5, 6, 7, 8, 9, 11, 12$;

$i = 2, j = 0, 1, 3, 4, 8, 10, 12, 13$;

$i = 3, j = 1, 2, 4, 5, 6, 7, 8, 9, 10, 13$;

$i = 4, j = 0, 1, 11, 14$;

$i = 5, j = 0, 1, 5, 7, 11, 15$;

$i = 6, j = 0, 5, 7, 9, 11, 16$;

$i = 7, j = 1, 5, 7, 11, 13, 17$;

$i = 8, j = 0, 1, 12, 18$;

$i = 9, j = 1, 8, 10, 11, 19$;

$i = 10, j = 0, 1, 6, 7, 20$;

$i = 11, j = 0, 7, 9, 13, 21$;

$i = 12, j = 1, 3, 11, 22$;

$i = 13, j = 0, 1, 8, 13, 23$;

$i = 14, j = 1, 6, 11, 13, 24$;

$i = 15, j = 0, 10, 11, 25$;

$i = 16, j = 1, 9, 11, 12, 26$;

$i = 17, j = 1, 5, 11, 12, 27$;

$i = 18, j = 0, 6, 7, 28$;

$i = 19, j = 0, 1, 10, 29$;

$i = 20, j = 1, 4, 11, 30;$
 $i = 21, j = 0, 8, 13, 31;$
 $i = 22, j = 1, 2, 32;$
 $i = 23, j = 0, 3, 5, 33;$
 $i = 24, j = 1, 2, 9, 34;$
 $i = 25, j = 0, 5, 35;$
 $i = 26, j = 2, 7, 12, 13, 36;$
 $i = 27, j = 0, 6, 37;$
 $i = 28, j = 1, 2, 5, 38;$
 $i = 29, j = 0, 4, 39;$
 $i = 30, j = 2, 5, 7, 9, 40;$
 $i = 31, j = 1, 13, 41;$
 $i = 32, j = 0, 5, 12, 42;$
 $i = 33, j = 2, 7, 10, 43;$
 $i = 34, j = 0, 12, 13, 44;$
 $i = 35, j = 1, 5, 11, 45;$
 $i = 36, j = 0, 2, 7, 46;$
 $i = 37, j = 10, 13, 47;$
 $i = 38, j = 1, 5, 11, 48;$
 $i = 39, j = 0, 7, 12, 49;$
 $i = 40, j = 2, 10, 13, 50;$
 $i = 41, j = 1, 5, 11, 51.$

36. An apparatus, comprising:

one or more memories configured to store program instructions; and

one or more processors coupled to the one or more memories and configured to execute the program instructions to cause the apparatus to:

encode an input sequence using a matrix H , to obtain an encoded sequence;

wherein the matrix H is determined according to a base matrix and a lifting factor Z , Z is a positive integer;

wherein the base matrix comprises m rows and n columns, and elements in the base matrix are respectively represented by their row index i and column index j , where $0 \leq i < m$, $0 \leq j < n$;

wherein an element in the base matrix is either a zero-element or non-zero-element;

the base matrix comprises one or more following rows with non-zero-elements, wherein row indexes (i), column indexes (j) of the non-zero-elements are as follows:

$i = 32, j = 0, 5, 12, 42;$
 $i = 33, j = 2, 7, 10, 43;$
 $i = 34, j = 0, 12, 13, 44;$
 $i = 35, j = 1, 5, 11, 45;$
 $i = 36, j = 0, 2, 7, 46;$
 $i = 37, j = 10, 13, 47;$
 $i = 38, j = 1, 5, 11, 48;$
 $i = 39, j = 0, 7, 12, 49;$
 $i = 40, j = 2, 10, 13, 50;$
 $i = 41, j = 1, 5, 11, 51.$

37. The apparatus according to claim 36, wherein the base matrix further comprises one or more following rows with non-zero-elements, wherein row indexes (i), column indexes (j) of the non-zero-elements are as follows:

$i = 0, j = 0, 1, 2, 3, 6, 9, 10, 11;$
 $i = 1, j = 0, 3, 4, 5, 6, 7, 8, 9, 11, 12;$
 $i = 2, j = 0, 1, 3, 4, 8, 10, 12, 13;$
 $i = 3, j = 1, 2, 4, 5, 6, 7, 8, 9, 10, 13;$
 $i = 4, j = 0, 1, 11, 14;$
 $i = 5, j = 0, 1, 5, 7, 11, 15;$
 $i = 6, j = 0, 5, 7, 9, 11, 16;$
 $i = 7, j = 1, 5, 7, 11, 13, 17;$
 $i = 8, j = 0, 1, 12, 18;$
 $i = 9, j = 1, 8, 10, 11, 19;$
 $i = 10, j = 0, 1, 6, 7, 20;$
 $i = 11, j = 0, 7, 9, 13, 21;$
 $i = 12, j = 1, 3, 11, 22;$
 $i = 13, j = 0, 1, 8, 13, 23;$
 $i = 14, j = 1, 6, 11, 13, 24;$
 $i = 15, j = 0, 10, 11, 25;$
 $i = 16, j = 1, 9, 11, 12, 26;$
 $i = 17, j = 1, 5, 11, 12, 27;$
 $i = 18, j = 0, 6, 7, 28;$
 $i = 19, j = 0, 1, 10, 29;$
 $i = 20, j = 1, 4, 11, 30;$

i = 21, j = 0, 8, 13, 31;

i = 22, j = 1, 2, 32;

i = 23, j = 0, 3, 5, 33;

i = 24, j = 1, 2, 9, 34;

i = 25, j = 0, 5, 35;

i = 26, j = 2, 7, 12, 13, 36;

i = 27, j = 0, 6, 37;

i = 28, j = 1, 2, 5, 38;

i = 29, j = 0, 4, 39;

i = 30, j = 2, 5, 7, 9, 40;

i = 31, j = 1, 13, 41.

38. The apparatus according to any one of claim 35 to 37, wherein the input sequence is represented as $c = \{c_0, c_1, c_2, \dots, c_{K-1}\}$, the encoded sequence is represented as $d = \{d_0, d_1, d_2, \dots, d_{N-1}\}$, wherein N is a positive integer, $N = (40+Kb) \times Z$, and Kb is one of $\{6, 8, 9, 10\}$.

39. The apparatus according to claim 38, wherein the encoded sequence d comprises K_0 bits in the input sequence c and $N-K_0$ parity bits in a parity sequence $w = \{w_0, w_1, w_2, \dots, w_{N-K_0-1}\}$, K_0 is an integer greater than 0 and less than or equal to K,

wherein the matrix H, the parity sequence w and the input sequence c meet:

$$H \times \begin{bmatrix} c^T \\ w^T \end{bmatrix} = 0^T,$$

wherein $c^T = [c_0, c_1, c_2, \dots, c_{K-1}]^T$, $w^T = [w_0, w_1, w_2, \dots, w_{N-K_0-1}]^T$, 0^T is a column vector, and values of all elements of 0^T are 0.

40. The apparatus according to claim 39, wherein $K_0 = K-2 \times Z$.

41. An apparatus, comprising:

one or more memories configured to store program instructions; and

one or more processors coupled to the one or more memories and configured to execute the program instructions to cause the apparatus to:

decode an input sequence using a matrix H, to obtain a decoded sequence;

wherein the matrix H is determined according to a base matrix and a lifting factor Z, Z is a positive integer;

wherein the base matrix comprises a plurality of rows and columns of a matrix H_B ;

wherein an element in the matrix H_B is either a zero-element or non-zero-element;

the matrix H_B comprises following rows with non-zero-elements, wherein row indexes (i), column indexes (j) of the non-zero-elements are as follows:

$i = 0, j = 0, 1, 2, 3, 6, 9, 10, 11;$
 $i = 1, j = 0, 3, 4, 5, 6, 7, 8, 9, 11, 12;$
 $i = 2, j = 0, 1, 3, 4, 8, 10, 12, 13;$
 $i = 3, j = 1, 2, 4, 5, 6, 7, 8, 9, 10, 13;$
 $i = 4, j = 0, 1, 11, 14;$
 $i = 5, j = 0, 1, 5, 7, 11, 15;$
 $i = 6, j = 0, 5, 7, 9, 11, 16;$
 $i = 7, j = 1, 5, 7, 11, 13, 17;$
 $i = 8, j = 0, 1, 12, 18;$
 $i = 9, j = 1, 8, 10, 11, 19;$
 $i = 10, j = 0, 1, 6, 7, 20;$
 $i = 11, j = 0, 7, 9, 13, 21;$
 $i = 12, j = 1, 3, 11, 22;$
 $i = 13, j = 0, 1, 8, 13, 23;$
 $i = 14, j = 1, 6, 11, 13, 24;$
 $i = 15, j = 0, 10, 11, 25;$
 $i = 16, j = 1, 9, 11, 12, 26;$
 $i = 17, j = 1, 5, 11, 12, 27;$
 $i = 18, j = 0, 6, 7, 28;$
 $i = 19, j = 0, 1, 10, 29;$
 $i = 20, j = 1, 4, 11, 30;$
 $i = 21, j = 0, 8, 13, 31;$
 $i = 22, j = 1, 2, 32;$
 $i = 23, j = 0, 3, 5, 33;$
 $i = 24, j = 1, 2, 9, 34;$
 $i = 25, j = 0, 5, 35;$
 $i = 26, j = 2, 7, 12, 13, 36;$
 $i = 27, j = 0, 6, 37;$
 $i = 28, j = 1, 2, 5, 38;$
 $i = 29, j = 0, 4, 39;$
 $i = 30, j = 2, 5, 7, 9, 40;$
 $i = 31, j = 1, 13, 41;$
 $i = 32, j = 0, 5, 12, 42;$
 $i = 33, j = 2, 7, 10, 43;$

$i = 34, j = 0, 12, 13, 44;$

$i = 35, j = 1, 5, 11, 45;$

$i = 36, j = 0, 2, 7, 46;$

$i = 37, j = 10, 13, 47;$

$i = 38, j = 1, 5, 11, 48;$

$i = 39, j = 0, 7, 12, 49;$

$i = 40, j = 2, 10, 13, 50;$

$i = 41, j = 1, 5, 11, 51.$

42. An apparatus, comprising:

one or more memories configured to store program instructions; and

one or more processors coupled to the one or more memories and configured to execute the program instructions to cause the apparatus to:

decode an input sequence using a matrix H , to obtain a decoded sequence;

wherein the matrix H is determined according to a base matrix and a lifting factor Z , Z is a positive integer;

wherein the base matrix comprises m rows and n columns, and elements in the base matrix are respectively represented by their row index i and column index j , where $0 \leq i < m$, $0 \leq j < n$;

wherein an element in the base matrix is either a zero-element or non-zero-element;

the base matrix comprises one or more following rows with non-zero-elements, wherein row indexes (i), column indexes (j) of the non-zero-elements are as follows:

$i = 32, j = 0, 5, 12, 42;$

$i = 33, j = 2, 7, 10, 43;$

$i = 34, j = 0, 12, 13, 44;$

$i = 35, j = 1, 5, 11, 45;$

$i = 36, j = 0, 2, 7, 46;$

$i = 37, j = 10, 13, 47;$

$i = 38, j = 1, 5, 11, 48;$

$i = 39, j = 0, 7, 12, 49;$

$i = 40, j = 2, 10, 13, 50;$

$i = 41, j = 1, 5, 11, 51.$

43. The apparatus according to claim 42, wherein the base matrix further comprises one or more following rows with non-zero-elements, wherein row indexes (i), column indexes (j) of the non-zero-elements are as follows:

$i = 0, j = 0, 1, 2, 3, 6, 9, 10, 11;$

$i = 1, j = 0, 3, 4, 5, 6, 7, 8, 9, 11, 12;$
 $i = 2, j = 0, 1, 3, 4, 8, 10, 12, 13;$
 $i = 3, j = 1, 2, 4, 5, 6, 7, 8, 9, 10, 13;$
 $i = 4, j = 0, 1, 11, 14;$
 $i = 5, j = 0, 1, 5, 7, 11, 15;$
 $i = 6, j = 0, 5, 7, 9, 11, 16;$
 $i = 7, j = 1, 5, 7, 11, 13, 17;$
 $i = 8, j = 0, 1, 12, 18;$
 $i = 9, j = 1, 8, 10, 11, 19;$
 $i = 10, j = 0, 1, 6, 7, 20;$
 $i = 11, j = 0, 7, 9, 13, 21;$
 $i = 12, j = 1, 3, 11, 22;$
 $i = 13, j = 0, 1, 8, 13, 23;$
 $i = 14, j = 1, 6, 11, 13, 24;$
 $i = 15, j = 0, 10, 11, 25;$
 $i = 16, j = 1, 9, 11, 12, 26;$
 $i = 17, j = 1, 5, 11, 12, 27;$
 $i = 18, j = 0, 6, 7, 28;$
 $i = 19, j = 0, 1, 10, 29;$
 $i = 20, j = 1, 4, 11, 30;$
 $i = 21, j = 0, 8, 13, 31;$
 $i = 22, j = 1, 2, 32;$
 $i = 23, j = 0, 3, 5, 33;$
 $i = 24, j = 1, 2, 9, 34;$
 $i = 25, j = 0, 5, 35;$
 $i = 26, j = 2, 7, 12, 13, 36;$
 $i = 27, j = 0, 6, 37;$
 $i = 28, j = 1, 2, 5, 38;$
 $i = 29, j = 0, 4, 39;$
 $i = 30, j = 2, 5, 7, 9, 40;$
 $i = 31, j = 1, 13, 41.$

44. The apparatus according to any one of claims 35 to 43, wherein each zero-element corresponds to an all-zero matrix of size $Z \times Z$ in the matrix H,

wherein each non-zero-element in row i and column j has a value V_{ij} and corresponds to a

circular permutation matrix $I(P_{i,j})$ of size $Z \times Z$ in the matrix H,

wherein $P_{i,j}$ is an integer shift value greater than or equal to zero, and $P_{i,j} = \text{mod}(V_{i,j}, Z)$.

45. The apparatus according to any one of claims 35 to 44, wherein the lifting factor Z is a minimum of a plurality of lifting factors satisfying a relationship of $10 \times Z = K$.

46. The apparatus according to any one of claims 35 to 45, wherein the lifting factor Z satisfies $Z = a \times 2^j$, where $a \in \{2, 3, 5, 7, 9, 11, 13, 15\}$, and

wherein:

in case of $a = 2, j = 0, 1, 2, 3, 4, 5, 6$ or 7 ;

in case of $a = 3, j = 0, 1, 2, 3, 4, 5, 6$ or 7 ;

in case of $a = 5, j = 0, 1, 2, 3, 4, 5$ or 6 ;

in case of $a = 7, j = 0, 1, 2, 3, 4$ or 5 ;

in case of $a = 9, j = 0, 1, 2, 3, 4$ or 5 ;

in case of $a = 11, j = 0, 1, 2, 3, 4$ or 5 ;

in case of $a = 13, j = 0, 1, 2, 3$ or 4 ; or

in case of $a = 15, j = 0, 1, 2, 3$ or 4 .

47. The apparatus according to any one of claims 35 to 46, wherein the lifting factor $Z = Z_0$, Z_0 is a minimum of a plurality of lifting factors satisfying a relationship of $Kb \times Z_0 \geq K$, and Kb is one of $\{6, 8, 9, 10\}$.

48. The apparatus according to claim 47, wherein

in case of $K > 640$, Kb equals to 10; or

in case of $K > 560$ and $K \leq 640$, Kb equals to 9; or

in case of $K > 192$ and $K \leq 560$, Kb equals to 8; or

in case of $K \leq 192$, Kb equals to 6.

49. The apparatus according to any one of claims 35 to 48, wherein the matrix H is determined according to a permuted matrix of the base matrix, and wherein the permuted matrix is obtained by performing row permutation, or column permutation, or row permutation and column permutation on the base matrix.

50. The apparatus according to any one of claims 35 to 49, further comprising one or more memories configured to store at least one of the base matrix, the matrix H_B , the permuted matrix, one or more lifting factors Z, or one or more circular permutation matrices.

51. The apparatus according to any one of claims 35 to 50, further comprising one or more memories configured to store parameters associated with the matrix H.

52. The apparatus according to any one of claims 35 to 40 and 44 to 51, further comprising:
a component configured to perform rate matching on the encoded sequence to obtain a rate

matched sequence;

a component configured to perform interleaving on the rate matched sequence to obtain a interleaved sequence; and

a component configured to modulate the interleaved sequence to obtain a signal.

53. The apparatus according to any one of claims 41 to 51, further comprising:

a demodulator, configured to demodulate a signal to obtain a demodulated sequence;

a deinterleaver, configured to perform deinterleaving on the demodulated sequence to obtain a deinterleaved sequence; and

a rate de-matching component, configured to perform rate de-matching on the deinterleaved sequence, to obtain the soft value sequence.

54. The apparatus according to claim 52 or 53, further comprising a transceiver, wherein the transceiver is configured to:

receive or transmit the signal.

55. A terminal, comprising the apparatus according to any one of claims 35 to 54.

56. A base station, comprising the apparatus according to any one of claims 35 to 54.

57. A communication system, comprising the terminal according to claim 55 and the base station according to claim 56.

58. A computer-readable storage medium, comprising one or more instructions, wherein when the one or more instructions are executed on a computer, cause the computer to perform the method according to any one of claims 1 to 34.

10a

1	1	1	1	1	1	1	1	1	1	1	1	1	1	1	1	1	1	0	0
1	1	1	1	1	1	1	1	1	1	1	1	1	1	1	1	1	1	1	0
1	0	1	1	1	1	1	1	1	1	1	1	1	1	1	1	1	0	1	0
1	1	0	0	0	0	0	0	0	0	0	0	0	0	0	0	0	0	0	1

10b

2	276	50	337	422	354	305	273	191	348	220	127	373	411	340	321	0	0	-1	-1
44	209	318	295	289	300	94	174	372	411	100	92	482	185	191	420	1	0	0	-1
294	-1	213	90	461	112	46	307	221	375	19	136	469	176	377	364	0	-1	0	-1
416	135	-1	-1	-1	-1	-1	-1	-1	-1	-1	-1	-1	-1	-1	-1	-1	-1	-1	0

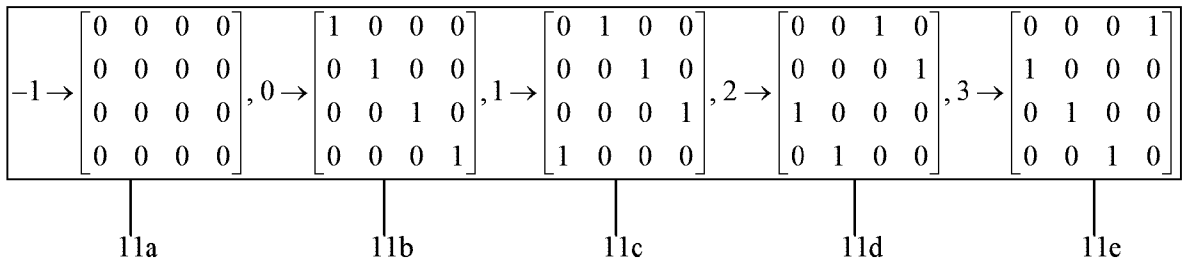

FIG. 1

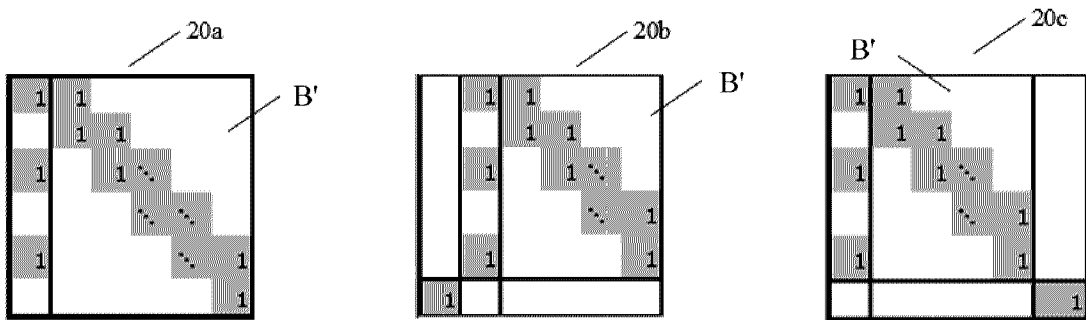
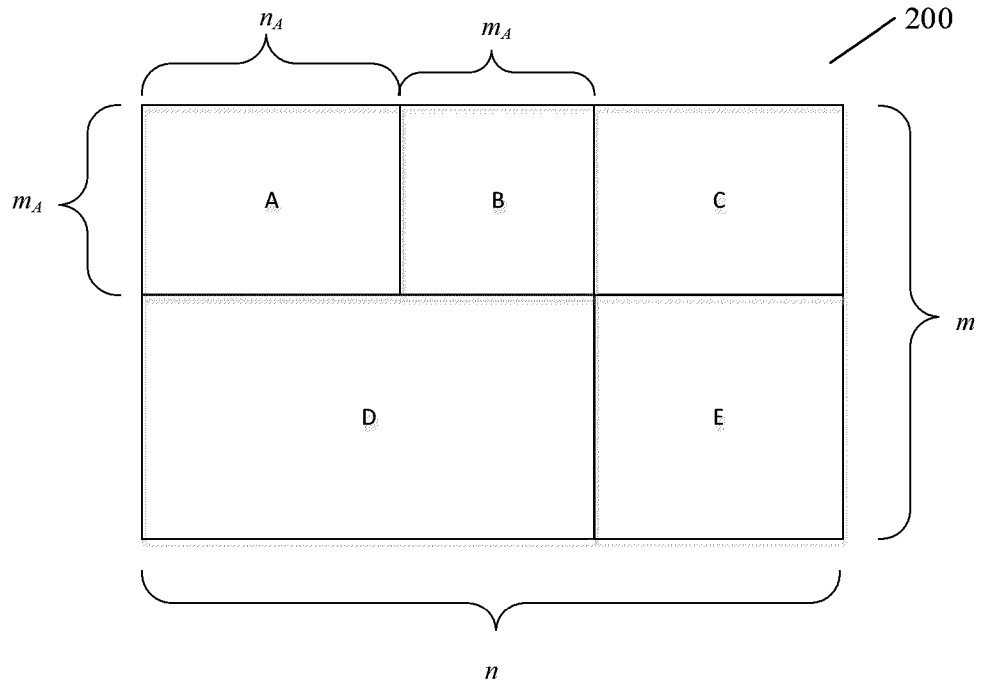

FIG. 2

30a

	0	1	2	3	4	5	6	7	8	9	10	11	12	13	14	15	16	17	18	50	51
0	1	1	1	1			1			1	1	1									
1	1			1	1	1	1	1	1	1		1	1								
2	1	1		1	1				1		1		1	1							
3		1	1		1	1	1	1	1	1				1							
4	1	1									1				1						
5	1	1				1		1			1					1					
6	1					1		1			1						1				
7		1						1						1	1						
8	1	1											1								
9		1						1			1	1									
10	1	1					1	1													
11	1							1			1				1						
12		1		1								1									
13	1	1							1						1	1					
14		1					1				1				1	1					
15	1										1	1									
16		1							1			1	1								
17		1					1					1	1								
18	1						1	1													
19	1	1									1										
20		1			1							1									
21	1								1						1						
22		1	1	1																	
23	1			1			1														
24		1	1								1										
25	1						1														
26			1					1						1	1						
27	1							1													
28		1	1				1														
29	1				1																
30			1			1		1			1										
31		1													1	1					
32	1						1							1							
33			1					1				1									
34	1													1	1						
35		1					1						1								
36	1		1					1													
37											1				1						
38		1					1							1							
39	1							1						1							
40			1								1				1						1
41		1					1					1									1

FIG. 3a

30b-1

	0	1	2	3	4	5	6	7	8	9	10	11	12	13	14	15	16	17	18	50	51
0	121	9	19	93	-1	-1	168	-1	-1	51	0	0	-1	-1	-1	-1	-1	-1	-1	-1	-1
1	116	-1	-1	149	111	2	21	184	140	69	-1	0	0	-1	-1	-1	-1	-1	-1	-1	-1
2	108	180	-1	147	77	-1	-1	-1	64	-1	1	-1	0	0	-1	-1	-1	-1	-1	-1	-1
3	-1	115	81	-1	163	187	56	73	14	22	0	-1	-1	0	-1	-1	-1	-1	-1	-1	-1
4	145	122	-1	-1	-1	-1	-1	-1	-1	-1	-1	67	-1	-1	0	-1	-1	-1	-1	-1	-1
5	124	121	-1	-1	-1	4	-1	37	-1	-1	-1	145	-1	-1	-1	0	-1	-1	-1	-1	-1
6	141	-1	-1	-1	-1	185	-1	124	-1	171	-1	151	-1	-1	-1	-1	0	-1	-1	-1	-1
7	-1	185	-1	-1	-1	150	-1	190	-1	-1	-1	165	-1	134	-1	-1	-1	0	-1	-1	-1
8	83	178	-1	-1	-1	-1	-1	-1	-1	-1	-1	-1	186	-1	-1	-1	-1	-1	0	-1	-1
9	-1	73	-1	-1	-1	-1	-1	-1	87	-1	175	123	-1	-1	-1	-1	-1	-1	-1	-1	-1
10	16	158	-1	-1	-1	-1	179	173	-1	-1	-1	-1	-1	-1	-1	-1	-1	-1	-1	-1	-1
11	130	-1	-1	-1	-1	-1	-1	104	-1	174	-1	-1	-1	52	-1	-1	-1	-1	-1	-1	-1
12	-1	179	-1	39	-1	-1	-1	-1	-1	-1	-1	139	-1	-1	-1	-1	-1	-1	-1	-1	-1
13	128	23	-1	-1	-1	-1	-1	-1	105	-1	-1	-1	-1	111	-1	-1	-1	-1	-1	-1	-1
14	-1	88	-1	-1	-1	-1	95	-1	-1	-1	-1	85	-1	187	-1	-1	-1	-1	-1	-1	-1
15	108	-1	-1	-1	-1	-1	-1	-1	-1	-1	60	98	-1	-1	-1	-1	-1	-1	-1	-1	-1
16	-1	130	-1	-1	-1	-1	-1	-1	-1	-1	12	-1	35	176	-1	-1	-1	-1	-1	-1	-1
17	-1	134	-1	-1	-1	19	-1	-1	-1	-1	-1	0	127	-1	-1	-1	-1	-1	-1	-1	-1
18	1	-1	-1	-1	-1	-1	78	163	-1	-1	-1	-1	-1	-1	-1	-1	-1	-1	-1	-1	-1
19	97	54	-1	-1	-1	-1	-1	-1	-1	-1	27	-1	-1	-1	-1	-1	-1	-1	-1	-1	-1
20	-1	94	-1	-1	28	-1	-1	-1	-1	-1	-1	185	-1	-1	-1	-1	-1	-1	-1	-1	-1
21	83	-1	-1	-1	-1	-1	-1	-1	79	-1	-1	-1	-1	116	-1	-1	-1	-1	-1	-1	-1
22	-1	22	67	-1	-1	-1	-1	-1	-1	-1	-1	-1	-1	-1	-1	-1	-1	-1	-1	-1	-1
23	97	-1	-1	43	-1	106	-1	-1	-1	-1	-1	-1	-1	-1	-1	-1	-1	-1	-1	-1	-1
24	-1	102	104	-1	-1	-1	-1	-1	-1	169	-1	-1	-1	-1	-1	-1	-1	-1	-1	-1	-1
25	171	-1	-1	-1	-1	121	-1	-1	-1	-1	-1	-1	-1	-1	-1	-1	-1	-1	-1	-1	-1
26	-1	-1	183	-1	-1	-1	-1	148	-1	-1	-1	-1	43	160	-1	-1	-1	-1	-1	-1	-1
27	108	-1	-1	-1	-1	-1	176	-1	-1	-1	-1	-1	-1	-1	-1	-1	-1	-1	-1	-1	-1
28	-1	118	161	-1	-1	191	-1	-1	-1	-1	-1	-1	-1	-1	-1	-1	-1	-1	-1	-1	-1
29	22	-1	-1	-1	22	-1	-1	-1	-1	-1	-1	-1	-1	-1	-1	-1	-1	-1	-1	-1	-1
30	-1	-1	135	-1	-1	74	-1	154	-1	6	-1	-1	-1	-1	-1	-1	-1	-1	-1	-1	-1
31	-1	137	-1	-1	-1	-1	-1	-1	-1	-1	-1	-1	-1	35	-1	-1	-1	-1	-1	-1	-1
32	105	-1	-1	-1	-1	116	-1	-1	-1	-1	-1	-1	132	-1	-1	-1	-1	-1	-1	-1	-1
33	-1	-1	146	-1	-1	-1	-1	158	-1	-1	59	-1	-1	-1	-1	-1	-1	-1	-1	-1	-1
34	37	-1	-1	-1	-1	-1	-1	-1	-1	-1	-1	-1	138	125	-1	-1	-1	-1	-1	-1	-1
35	-1	73	-1	-1	-1	95	-1	-1	-1	-1	-1	128	-1	-1	-1	-1	-1	-1	-1	-1	-1
36	47	-1	131	-1	-1	-1	-1	154	-1	-1	-1	-1	-1	-1	-1	-1	-1	-1	-1	-1	-1
37	-1	-1	-1	-1	-1	-1	-1	-1	-1	-1	58	-1	-1	137	-1	-1	-1	-1	-1	-1	-1
38	-1	29	-1	-1	-1	124	-1	-1	-1	-1	-1	123	-1	-1	-1	-1	-1	-1	-1	-1	-1
39	175	-1	-1	-1	-1	-1	-1	74	-1	-1	-1	-1	147	-1	-1	-1	-1	-1	-1	-1	-1
40	-1	-1	51	-1	-1	-1	-1	-1	-1	-1	87	-1	-1	167	-1	-1	-1	-1	-1	0	-1
41	-1	27	-1	-1	-1	17	-1	-1	-1	-1	-1	1	-1	-1	-1	-1	-1	-1	-1	-1	0

FIG. 3b-1

30b-2

	0	1	2	3	4	5	6	7	8	9	10	11	12	13	14	15	16	17	18	50	51
0	121	74	89	122	-1	-1	141	-1	-1	137	0	0	-1	-1	-1	-1	-1	-1	-1	-1	-1
1	118	-1	-1	0	25	171	133	79	173	121	-1	0	0	-1	-1	-1	-1	-1	-1	-1	-1
2	42	121	-1	95	8	-1	-1	-1	29	-1	1	-1	0	0	-1	-1	-1	-1	-1	-1	-1
3	-1	64	110	-1	143	78	90	9	55	90	0	-1	-1	0	-1	-1	-1	-1	-1	-1	-1
4	31	48	-1	-1	-1	-1	-1	-1	-1	-1	-1	162	-1	-1	0	-1	-1	-1	-1	-1	-1
5	28	29	-1	-1	-1	99	-1	142	-1	-1	-1	80	-1	-1	-1	0	-1	-1	-1	-1	-1
6	17	-1	-1	-1	-1	38	-1	63	-1	26	-1	167	-1	-1	-1	-1	0	-1	-1	-1	-1
7	-1	44	-1	-1	-1	68	-1	59	-1	-1	-1	110	-1	86	-1	-1	-1	0	-1	-1	-1
8	104	58	-1	-1	-1	-1	-1	-1	-1	-1	-1	-1	53	-1	-1	-1	-1	-1	0	-1	-1
9	-1	136	-1	-1	-1	-1	-1	-1	135	-1	133	142	-1	-1	-1	-1	-1	-1	-1	-1	-1
10	153	15	-1	-1	-1	-1	109	86	-1	-1	-1	-1	-1	-1	-1	-1	-1	-1	-1	-1	-1
11	4	-1	-1	-1	-1	-1	-1	34	-1	168	-1	-1	-1	156	-1	-1	-1	-1	-1	-1	-1
12	-1	98	-1	60	-1	-1	-1	-1	-1	-1	-1	172	-1	-1	-1	-1	-1	-1	-1	-1	-1
13	98	3	-1	-1	-1	-1	-1	-1	89	-1	-1	-1	-1	108	-1	-1	-1	-1	-1	-1	-1
14	-1	30	-1	-1	-1	-1	131	-1	-1	-1	-1	127	-1	112	-1	-1	-1	-1	-1	-1	-1
15	38	-1	-1	-1	-1	-1	-1	-1	-1	-1	64	77	-1	-1	-1	-1	-1	-1	-1	-1	-1
16	-1	110	-1	-1	-1	-1	-1	-1	-1	42	-1	10	82	-1	-1	-1	-1	-1	-1	-1	-1
17	-1	48	-1	-1	-1	66	-1	-1	-1	-1	-1	61	161	-1	-1	-1	-1	-1	-1	-1	-1
18	90	-1	-1	-1	-1	-1	47	63	-1	-1	-1	-1	-1	-1	-1	-1	-1	-1	-1	-1	-1
19	175	87	-1	-1	-1	-1	-1	-1	-1	-1	59	-1	-1	-1	-1	-1	-1	-1	-1	-1	-1
20	-1	88	-1	-1	150	-1	-1	-1	-1	-1	-1	12	-1	-1	-1	-1	-1	-1	-1	-1	-1
21	5	-1	-1	-1	-1	-1	-1	-1	79	-1	-1	-1	-1	137	-1	-1	-1	-1	-1	-1	-1
22	-1	43	127	-1	-1	-1	-1	-1	-1	-1	-1	-1	-1	-1	-1	-1	-1	-1	-1	-1	-1
23	78	-1	-1	32	-1	169	-1	-1	-1	-1	-1	-1	-1	-1	-1	-1	-1	-1	-1	-1	-1
24	-1	1	130	-1	-1	-1	-1	-1	-1	13	-1	-1	-1	-1	-1	-1	-1	-1	-1	-1	-1
25	39	-1	-1	-1	-1	21	-1	-1	-1	-1	-1	-1	-1	-1	-1	-1	-1	-1	-1	-1	-1
26	-1	-1	23	-1	-1	-1	-1	82	-1	-1	-1	-1	121	156	-1	-1	-1	-1	-1	-1	-1
27	74	-1	-1	-1	-1	-1	166	-1	-1	-1	-1	-1	-1	-1	-1	-1	-1	-1	-1	-1	-1
28	-1	22	19	-1	-1	42	-1	-1	-1	-1	-1	-1	-1	-1	-1	-1	-1	-1	-1	-1	-1
29	91	-1	-1	-1	33	-1	-1	-1	-1	-1	-1	-1	-1	-1	-1	-1	-1	-1	-1	-1	-1
30	-1	-1	16	-1	-1	140	-1	56	-1	158	-1	-1	-1	-1	-1	-1	-1	-1	-1	-1	-1
31	-1	165	-1	-1	-1	-1	-1	-1	-1	-1	-1	-1	-1	23	-1	-1	-1	-1	-1	-1	-1
32	34	-1	-1	-1	-1	4	-1	-1	-1	-1	-1	-1	18	-1	-1	-1	-1	-1	-1	-1	-1
33	-1	-1	152	-1	-1	-1	-1	131	-1	-1	5	-1	-1	-1	-1	-1	-1	-1	-1	-1	-1
34	148	-1	-1	-1	-1	-1	-1	-1	-1	-1	-1	-1	82	153	-1	-1	-1	-1	-1	-1	-1
35	-1	124	-1	-1	-1	48	-1	-1	-1	-1	-1	8	-1	-1	-1	-1	-1	-1	-1	-1	-1
36	128	-1	50	-1	-1	-1	-1	6	-1	-1	-1	-1	-1	-1	-1	-1	-1	-1	-1	-1	-1
37	-1	-1	-1	-1	-1	-1	-1	-1	-1	-1	-1	31	-1	-1	120	-1	-1	-1	-1	-1	-1
38	-1	142	-1	-1	-1	119	-1	-1	-1	-1	-1	69	-1	-1	-1	-1	-1	-1	-1	-1	-1
39	69	-1	-1	-1	-1	-1	-1	124	-1	-1	-1	-1	33	-1	-1	-1	-1	-1	-1	-1	-1
40	-1	-1	72	-1	-1	-1	-1	-1	-1	-1	141	-1	-1	18	-1	-1	-1	-1	-1	0	-1
41	-1	4	-1	-1	-1	92	-1	-1	-1	-1	-1	37	-1	-1	-1	-1	-1	-1	-1	-1	0

FIG. 3b-2

30b-3

	0	1	2	3	4	5	6	7	8	9	10	11	12	13	14	15	16	17	18	50	51	
0	94	136	3	2	-1	-1	15	-1	-1	71	0	0	-1	-1	-1	-1	-1	-1	-1	-1	-1	
1	71	-1	-1	126	0	119	103	34	75	126	-1	0	0	-1	-1	-1	-1	-1	-1	-1	-1	
2	114	70	-1	101	9	-1	-1	-1	23	-1	1	-1	0	0	-1	-1	-1	-1	-1	-1	-1	
3	-1	14	18	-1	102	105	27	91	128	117	0	-1	-1	0	-1	-1	-1	-1	-1	-1	-1	
4	33	51	-1	-1	-1	-1	-1	-1	-1	-1	-1	96	-1	-1	0	-1	-1	-1	-1	-1	-1	
5	40	53	-1	-1	-1	47	-1	121	-1	-1	-1	10	-1	-1	-1	0	-1	-1	-1	-1	-1	
6	110	-1	-1	-1	-1	99	-1	149	-1	132	-1	4	-1	-1	-1	-1	0	-1	-1	-1	-1	
7	-1	83	-1	-1	-1	111	-1	129	-1	-1	-1	43	-1	25	-1	-1	-1	-1	0	-1	-1	-1
8	94	41	-1	-1	-1	-1	-1	-1	-1	-1	-1	-1	87	-1	-1	-1	-1	-1	-1	0	-1	-1
9	-1	135	-1	-1	-1	-1	-1	-1	11	-1	50	84	-1	-1	-1	-1	-1	-1	-1	-1	-1	
10	154	34	-1	-1	-1	-1	141	86	-1	-1	-1	-1	-1	-1	-1	-1	-1	-1	-1	-1	-1	
11	54	-1	-1	-1	-1	-1	-1	40	-1	84	-1	-1	-1	43	-1	-1	-1	-1	-1	-1	-1	
12	-1	31	-1	90	-1	-1	-1	-1	-1	-1	-1	113	-1	-1	-1	-1	-1	-1	-1	-1	-1	
13	41	86	-1	-1	-1	-1	-1	-1	16	-1	-1	-1	-1	79	-1	-1	-1	-1	-1	-1	-1	
14	-1	10	-1	-1	-1	-1	28	-1	-1	-1	-1	128	-1	104	-1	-1	-1	-1	-1	-1	-1	
15	65	-1	-1	-1	-1	-1	-1	-1	-1	-1	110	93	-1	-1	-1	-1	-1	-1	-1	-1	-1	
16	-1	24	-1	-1	-1	-1	-1	-1	-1	63	-1	0	33	-1	-1	-1	-1	-1	-1	-1	-1	
17	-1	35	-1	-1	-1	100	-1	-1	-1	-1	-1	86	0	-1	-1	-1	-1	-1	-1	-1	-1	
18	129	-1	-1	-1	-1	-1	37	149	-1	-1	-1	-1	-1	-1	-1	-1	-1	-1	-1	-1	-1	
19	117	48	-1	-1	-1	-1	-1	-1	-1	-1	136	-1	-1	-1	-1	-1	-1	-1	-1	-1	-1	
20	-1	47	-1	-1	28	-1	-1	-1	-1	-1	-1	150	-1	-1	-1	-1	-1	-1	-1	-1	-1	
21	56	-1	-1	-1	-1	-1	-1	-1	118	-1	-1	-1	-1	126	-1	-1	-1	-1	-1	-1	-1	
22	-1	40	125	-1	-1	-1	-1	-1	-1	-1	-1	-1	-1	-1	-1	-1	-1	-1	-1	-1	-1	
23	7	-1	-1	113	-1	65	-1	-1	-1	-1	-1	-1	-1	-1	-1	-1	-1	-1	-1	-1	-1	
24	-1	135	16	-1	-1	-1	-1	-1	-1	93	-1	-1	-1	-1	-1	-1	-1	-1	-1	-1	-1	
25	80	-1	-1	-1	-1	143	-1	-1	-1	-1	-1	-1	-1	-1	-1	-1	-1	-1	-1	-1	-1	
26	-1	-1	42	-1	-1	-1	-1	144	-1	-1	-1	-1	125	19	-1	-1	-1	-1	-1	-1	-1	
27	144	-1	-1	-1	-1	-1	100	-1	-1	-1	-1	-1	-1	-1	-1	-1	-1	-1	-1	-1	-1	
28	-1	124	52	-1	-1	116	-1	-1	-1	-1	-1	-1	-1	-1	-1	-1	-1	-1	-1	-1	-1	
29	141	-1	-1	-1	120	-1	-1	-1	-1	-1	-1	-1	-1	-1	-1	-1	-1	-1	-1	-1	-1	
30	-1	-1	68	-1	-1	33	-1	62	-1	32	-1	-1	-1	-1	-1	-1	-1	-1	-1	-1	-1	
31	-1	94	-1	-1	-1	-1	-1	-1	-1	-1	-1	-1	-1	121	-1	-1	-1	-1	-1	-1	-1	
32	0	-1	-1	-1	-1	133	-1	-1	-1	-1	-1	-1	92	-1	-1	-1	-1	-1	-1	-1	-1	
33	-1	-1	6	-1	-1	-1	-1	103	-1	-1	89	-1	-1	-1	-1	-1	-1	-1	-1	-1	-1	
34	70	-1	-1	-1	-1	-1	-1	-1	-1	-1	-1	-1	78	127	-1	-1	-1	-1	-1	-1	-1	
35	-1	63	-1	-1	-1	132	-1	-1	-1	-1	-1	36	-1	-1	-1	-1	-1	-1	-1	-1	-1	
36	99	-1	83	-1	-1	-1	-1	108	-1	-1	-1	-1	-1	-1	-1	-1	-1	-1	-1	-1	-1	
37	-1	-1	-1	-1	-1	-1	-1	-1	-1	-1	50	-1	-1	97	-1	-1	-1	-1	-1	-1	-1	
38	-1	151	-1	-1	-1	64	-1	-1	-1	-1	-1	32	-1	-1	-1	-1	-1	-1	-1	-1	-1	
39	27	-1	-1	-1	-1	-1	-1	61	-1	-1	-1	-1	51	-1	-1	-1	-1	-1	-1	-1	-1	
40	-1	-1	78	-1	-1	-1	-1	-1	-1	-1	-1	76	-1	-1	111	-1	-1	-1	-1	0	-1	
41	-1	30	-1	-1	-1	156	-1	-1	-1	-1	-1	103	-1	-1	-1	-1	-1	-1	-1	-1	0	

FIG. 3b-3

30b-4

	0	1	2	3	4	5	6	7	8	9	10	11	12	13	14	15	16	17	18	50	51
0	6	11	117	94	-1	-1	36	-1	-1	2	0	0	-1	-1	-1	-1	-1	-1	-1	-1	-1
1	63	-1	-1	100	10	4	52	13	26	97	-1	0	0	-1	-1	-1	-1	-1	-1	-1	-1
2	3	36	-1	3	142	-1	-1	-1	34	-1	1	-1	0	0	-1	-1	-1	-1	-1	-1	-1
3	-1	88	125	-1	127	7	11	68	112	23	0	-1	-1	0	-1	-1	-1	-1	-1	-1	-1
4	106	37	-1	-1	-1	-1	-1	-1	-1	-1	-1	27	-1	-1	0	-1	-1	-1	-1	-1	-1
5	15	133	-1	-1	-1	21	-1	101	-1	-1	-1	46	-1	-1	-1	0	-1	-1	-1	-1	-1
6	26	-1	-1	-1	-1	34	-1	37	-1	99	-1	139	-1	-1	-1	-1	0	-1	-1	-1	-1
7	-1	136	-1	-1	-1	61	-1	120	-1	-1	-1	133	-1	77	-1	-1	-1	0	-1	-1	-1
8	77	4	-1	-1	-1	-1	-1	-1	-1	-1	-1	-1	72	-1	-1	-1	-1	-1	0	-1	-1
9	-1	18	-1	-1	-1	-1	-1	-1	13	-1	77	22	-1	-1	-1	-1	-1	-1	-1	-1	-1
10	37	102	-1	-1	-1	-1	131	103	-1	-1	-1	-1	-1	-1	-1	-1	-1	-1	-1	-1	-1
11	50	-1	-1	-1	-1	-1	-1	103	-1	95	-1	-1	-1	103	-1	-1	-1	-1	-1	-1	-1
12	-1	65	-1	105	-1	-1	-1	-1	-1	-1	-1	88	-1	-1	-1	-1	-1	-1	-1	-1	-1
13	77	95	-1	-1	-1	-1	-1	-1	14	-1	-1	-1	-1	105	-1	-1	-1	-1	-1	-1	-1
14	-1	49	-1	-1	-1	-1	55	-1	-1	-1	-1	41	-1	124	-1	-1	-1	-1	-1	-1	-1
15	21	-1	-1	-1	-1	-1	-1	-1	-1	-1	90	22	-1	-1	-1	-1	-1	-1	-1	-1	-1
16	-1	129	-1	-1	-1	-1	-1	-1	-1	9	-1	68	37	-1	-1	-1	-1	-1	-1	-1	-1
17	-1	25	-1	-1	-1	143	-1	-1	-1	-1	-1	34	10	-1	-1	-1	-1	-1	-1	-1	-1
18	98	-1	-1	-1	-1	-1	112	78	-1	-1	-1	-1	-1	-1	-1	-1	-1	-1	-1	-1	-1
19	51	37	-1	-1	-1	-1	-1	-1	-1	-1	86	-1	-1	-1	-1	-1	-1	-1	-1	-1	-1
20	-1	67	-1	-1	0	-1	-1	-1	-1	-1	-1	101	-1	-1	-1	-1	-1	-1	-1	-1	-1
21	135	-1	-1	-1	-1	-1	-1	-1	52	-1	-1	-1	-1	88	-1	-1	-1	-1	-1	-1	-1
22	-1	136	-1	-1	-1	-1	-1	-1	-1	-1	-1	-1	-1	-1	-1	-1	-1	-1	-1	-1	-1
23	9	-1	-1	142	-1	121	-1	-1	-1	-1	-1	-1	-1	-1	-1	-1	-1	-1	-1	-1	-1
24	-1	122	26	-1	-1	-1	-1	-1	-1	125	-1	-1	-1	-1	-1	-1	-1	-1	-1	-1	-1
25	10	-1	-1	-1	-1	128	-1	-1	-1	-1	-1	-1	-1	-1	-1	-1	-1	-1	-1	-1	-1
26	-1	-1	111	-1	-1	-1	-1	106	-1	-1	-1	-1	142	98	-1	-1	-1	-1	-1	-1	-1
27	19	-1	-1	-1	-1	-1	7	-1	-1	-1	-1	-1	-1	-1	-1	-1	-1	-1	-1	-1	-1
28	-1	55	68	-1	-1	120	-1	-1	-1	-1	-1	-1	-1	-1	-1	-1	-1	-1	-1	-1	-1
29	40	-1	-1	-1	19	-1	-1	-1	-1	-1	-1	-1	-1	-1	-1	-1	-1	-1	-1	-1	-1
30	-1	-1	126	-1	-1	113	-1	112	-1	37	-1	-1	-1	-1	-1	-1	-1	-1	-1	-1	-1
31	-1	107	-1	-1	-1	-1	-1	-1	-1	-1	-1	-1	-1	130	-1	-1	-1	-1	-1	-1	-1
32	2	-1	-1	-1	-1	66	-1	-1	-1	-1	-1	-1	68	-1	-1	-1	-1	-1	-1	-1	-1
33	-1	-1	95	-1	-1	-1	-1	115	-1	-1	37	-1	-1	-1	-1	-1	-1	-1	-1	-1	-1
34	56	-1	-1	-1	-1	-1	-1	-1	-1	-1	-1	-1	10	16	-1	-1	-1	-1	-1	-1	-1
35	-1	12	-1	-1	-1	43	-1	-1	-1	-1	-1	15	-1	-1	-1	-1	-1	-1	-1	-1	-1
36	96	-1	116	-1	-1	-1	-1	70	-1	-1	-1	-1	-1	-1	-1	-1	-1	-1	-1	-1	-1
37	-1	-1	-1	-1	-1	-1	-1	-1	-1	-1	31	-1	-1	74	-1	-1	-1	-1	-1	-1	-1
38	-1	124	-1	-1	-1	91	-1	-1	-1	-1	-1	100	-1	-1	-1	-1	-1	-1	-1	-1	-1
39	11	-1	-1	-1	-1	-1	-1	2	-1	-1	-1	-1	121	-1	-1	-1	-1	-1	-1	-1	-1
40	-1	-1	101	-1	-1	-1	-1	-1	-1	-1	24	-1	-1	37	-1	-1	-1	-1	-1	0	-1
41	-1	88	-1	-1	-1	89	-1	-1	-1	-1	-1	23	-1	-1	-1	-1	-1	-1	-1	-1	0

FIG. 3b-4

30b-5

	0	1	2	3	4	5	6	7	8	9	10	11	12	13	14	15	16	17	18	50	51
0	109	223	171	209	-1	-1	4	-1	-1	0	0	0	-1	-1	-1	-1	-1	-1	-1	-1	-1
1	36	-1	-1	236	40	226	226	157	11	204	-1	0	0	-1	-1	-1	-1	-1	-1	-1	-1
2	15	131	-1	70	84	-1	-1	-1	170	-1	1	-1	0	0	-1	-1	-1	-1	-1	-1	-1
3	-1	135	193	-1	97	158	177	11	96	223	0	-1	-1	0	-1	-1	-1	-1	-1	-1	-1
4	117	19	-1	-1	-1	-1	-1	-1	-1	-1	-1	78	-1	-1	0	-1	-1	-1	-1	-1	-1
5	40	119	-1	-1	-1	116	-1	133	-1	-1	-1	102	-1	-1	-1	0	-1	-1	-1	-1	-1
6	6	-1	-1	-1	-1	37	-1	77	-1	213	-1	138	-1	-1	-1	-1	0	-1	-1	-1	-1
7	-1	156	-1	-1	-1	215	-1	29	-1	-1	-1	120	-1	243	-1	-1	-1	0	-1	-1	-1
8	76	167	-1	-1	-1	-1	-1	-1	-1	-1	-1	-1	210	-1	-1	-1	-1	-1	0	-1	-1
9	-1	241	-1	-1	-1	-1	-1	-1	44	-1	22	51	-1	-1	-1	-1	-1	-1	-1	-1	-1
10	244	221	-1	-1	-1	-1	206	250	-1	-1	-1	-1	-1	-1	-1	-1	-1	-1	-1	-1	-1
11	194	-1	-1	-1	-1	-1	-1	174	-1	95	-1	-1	-1	199	-1	-1	-1	-1	-1	-1	-1
12	-1	66	-1	134	-1	-1	-1	-1	-1	-1	-1	255	-1	-1	-1	-1	-1	-1	-1	-1	-1
13	98	159	-1	-1	-1	-1	-1	-1	68	-1	-1	-1	-1	17	-1	-1	-1	-1	-1	-1	-1
14	-1	245	-1	-1	-1	-1	185	-1	-1	-1	-1	91	-1	249	-1	-1	-1	-1	-1	-1	-1
15	53	-1	-1	-1	-1	-1	-1	-1	-1	-1	237	103	-1	-1	-1	-1	-1	-1	-1	-1	-1
16	-1	19	-1	-1	-1	-1	-1	-1	-1	214	-1	151	241	-1	-1	-1	-1	-1	-1	-1	-1
17	-1	185	-1	-1	-1	237	-1	-1	-1	-1	-1	41	122	-1	-1	-1	-1	-1	-1	-1	-1
18	111	-1	-1	-1	-1	-1	211	225	-1	-1	-1	-1	-1	-1	-1	-1	-1	-1	-1	-1	-1
19	150	38	-1	-1	-1	-1	-1	-1	-1	-1	66	-1	-1	-1	-1	-1	-1	-1	-1	-1	-1
20	-1	191	-1	-1	250	-1	-1	-1	-1	-1	-1	214	-1	-1	-1	-1	-1	-1	-1	-1	-1
21	2	-1	-1	-1	-1	-1	-1	-1	232	-1	-1	-1	-1	76	-1	-1	-1	-1	-1	-1	-1
22	-1	147	134	-1	-1	-1	-1	-1	-1	-1	-1	-1	-1	-1	-1	-1	-1	-1	-1	-1	-1
23	25	-1	-1	235	-1	194	-1	-1	-1	-1	-1	-1	-1	-1	-1	-1	-1	-1	-1	-1	-1
24	-1	6	11	-1	-1	-1	-1	-1	-1	173	-1	-1	-1	-1	-1	-1	-1	-1	-1	-1	-1
25	11	-1	-1	-1	-1	0	-1	-1	-1	-1	-1	-1	-1	-1	-1	-1	-1	-1	-1	-1	-1
26	-1	-1	6	-1	-1	-1	-1	232	-1	-1	-1	-1	226	202	-1	-1	-1	-1	-1	-1	-1
27	232	-1	-1	-1	-1	-1	19	-1	-1	-1	-1	-1	-1	-1	-1	-1	-1	-1	-1	-1	-1
28	-1	193	23	-1	-1	142	-1	-1	-1	-1	-1	-1	-1	-1	-1	-1	-1	-1	-1	-1	-1
29	0	-1	-1	-1	112	-1	-1	-1	-1	-1	-1	-1	-1	-1	-1	-1	-1	-1	-1	-1	-1
30	-1	-1	31	-1	-1	245	-1	12	-1	2	-1	-1	-1	-1	-1	-1	-1	-1	-1	-1	-1
31	-1	0	-1	-1	-1	-1	-1	-1	-1	-1	-1	-1	-1	152	-1	-1	-1	-1	-1	-1	-1
32	5	-1	-1	-1	-1	24	-1	-1	-1	-1	-1	-1	132	-1	-1	-1	-1	-1	-1	-1	-1
33	-1	-1	80	-1	-1	-1	-1	145	-1	-1	26	-1	-1	-1	-1	-1	-1	-1	-1	-1	-1
34	27	-1	-1	-1	-1	-1	-1	-1	-1	-1	-1	-1	192	73	-1	-1	-1	-1	-1	-1	-1
35	-1	84	-1	-1	-1	218	-1	-1	-1	-1	-1	201	-1	-1	-1	-1	-1	-1	-1	-1	-1
36	164	-1	115	-1	-1	-1	-1	183	-1	-1	-1	-1	-1	-1	-1	-1	-1	-1	-1	-1	-1
37	-1	-1	-1	-1	-1	-1	-1	-1	-1	-1	19	-1	-1	20	-1	-1	-1	-1	-1	-1	-1
38	-1	109	-1	-1	-1	143	-1	-1	-1	-1	-1	119	-1	-1	-1	-1	-1	-1	-1	-1	-1
39	180	-1	-1	-1	-1	-1	-1	143	-1	-1	-1	-1	135	-1	-1	-1	-1	-1	-1	-1	-1
40	-1	-1	164	-1	-1	-1	-1	-1	-1	-1	31	-1	-1	13	-1	-1	-1	-1	-1	0	-1
41	-1	230	-1	-1	-1	167	-1	-1	-1	-1	-1	122	-1	-1	-1	-1	-1	-1	-1	-1	0

FIG. 3b-5

30b-6

	0	1	2	3	4	5	6	7	8	9	10	11	12	13	14	15	16	17	18	50	51
0	56	19	221	119	-1	-1	219	-1	-1	33	0	0	-1	-1	-1	-1	-1	-1	-1	-1	-1
1	119	-1	-1	5	115	64	208	120	95	131	-1	0	0	-1	-1	-1	-1	-1	-1	-1	-1
2	156	156	-1	161	84	-1	-1	-1	145	-1	1	-1	0	-1	-1	-1	-1	-1	-1	-1	-1
3	-1	26	64	-1	118	197	186	106	127	186	0	-1	-1	0	-1	-1	-1	-1	-1	-1	-1
4	171	69	-1	-1	-1	-1	-1	-1	-1	-1	-1	168	-1	-1	0	-1	-1	-1	-1	-1	-1
5	120	154	-1	-1	-1	27	-1	212	-1	-1	-1	202	-1	-1	-1	0	-1	-1	-1	-1	-1
6	89	-1	-1	-1	-1	2	-1	20	-1	5	-1	218	-1	-1	-1	-1	0	-1	-1	-1	-1
7	-1	239	-1	-1	-1	75	-1	165	-1	-1	-1	24	-1	20	-1	-1	-1	0	-1	-1	-1
8	229	144	-1	-1	-1	-1	-1	-1	-1	-1	-1	159	-1	-1	-1	-1	-1	0	-1	-1	
9	-1	234	-1	-1	-1	-1	-1	-1	2	-1	67	129	-1	-1	-1	-1	-1	-1	-1	-1	-1
10	178	155	-1	-1	-1	-1	217	237	-1	-1	-1	-1	-1	-1	-1	-1	-1	-1	-1	-1	-1
11	187	-1	-1	-1	-1	-1	-1	185	-1	180	-1	-1	-1	22	-1	-1	-1	-1	-1	-1	-1
12	-1	171	-1	118	-1	-1	-1	-1	-1	-1	-1	221	-1	-1	-1	-1	-1	-1	-1	-1	-1
13	154	14	-1	-1	-1	-1	-1	-1	104	-1	-1	-1	-1	61	-1	-1	-1	-1	-1	-1	-1
14	-1	105	-1	-1	-1	-1	146	-1	-1	-1	-1	38	-1	76	-1	-1	-1	-1	-1	-1	-1
15	231	-1	-1	-1	-1	-1	-1	-1	-1	-1	149	173	-1	-1	-1	-1	-1	-1	-1	-1	-1
16	-1	145	-1	-1	-1	-1	-1	-1	-1	196	-1	16	168	-1	-1	-1	-1	-1	-1	-1	-1
17	-1	206	-1	-1	-1	170	-1	-1	-1	-1	-1	43	234	-1	-1	-1	-1	-1	-1	-1	-1
18	61	-1	-1	-1	-1	-1	36	109	-1	-1	-1	-1	-1	-1	-1	-1	-1	-1	-1	-1	-1
19	16	153	-1	-1	-1	-1	-1	-1	-1	-1	85	-1	-1	-1	-1	-1	-1	-1	-1	-1	-1
20	-1	108	-1	-1	39	-1	-1	-1	-1	-1	-1	31	-1	-1	-1	-1	-1	-1	-1	-1	-1
21	118	-1	-1	-1	-1	-1	-1	-1	97	-1	-1	-1	-1	44	-1	-1	-1	-1	-1	-1	-1
22	-1	17	188	-1	-1	-1	-1	-1	-1	-1	-1	-1	-1	-1	-1	-1	-1	-1	-1	-1	-1
23	16	-1	-1	52	-1	101	-1	-1	-1	-1	-1	-1	-1	-1	-1	-1	-1	-1	-1	-1	-1
24	-1	199	137	-1	-1	-1	-1	-1	-1	194	-1	-1	-1	-1	-1	-1	-1	-1	-1	-1	-1
25	17	-1	-1	-1	-1	115	-1	-1	-1	-1	-1	-1	-1	-1	-1	-1	-1	-1	-1	-1	-1
26	-1	-1	239	-1	-1	-1	-1	173	-1	-1	-1	-1	193	116	-1	-1	-1	-1	-1	-1	-1
27	18	-1	-1	-1	-1	-1	171	-1	-1	-1	-1	-1	-1	-1	-1	-1	-1	-1	-1	-1	-1
28	-1	88	128	-1	-1	66	-1	-1	-1	-1	-1	-1	-1	-1	-1	-1	-1	-1	-1	-1	-1
29	181	-1	-1	-1	13	-1	-1	-1	-1	-1	-1	-1	-1	-1	-1	-1	-1	-1	-1	-1	-1
30	-1	-1	231	-1	-1	177	-1	12	-1	17	-1	-1	-1	-1	-1	-1	-1	-1	-1	-1	-1
31	-1	6	-1	-1	-1	-1	-1	-1	-1	-1	-1	-1	-1	204	-1	-1	-1	-1	-1	-1	-1
32	130	-1	-1	-1	-1	214	-1	-1	-1	-1	-1	67	-1	-1	-1	-1	-1	-1	-1	-1	-1
33	-1	-1	235	-1	-1	-1	-1	192	-1	-1	65	-1	-1	-1	-1	-1	-1	-1	-1	-1	-1
34	123	-1	-1	-1	-1	-1	-1	-1	-1	-1	-1	42	2	-1	-1	-1	-1	-1	-1	-1	-1
35	-1	123	-1	-1	-1	135	-1	-1	-1	-1	5	-1	-1	-1	-1	-1	-1	-1	-1	-1	-1
36	125	-1	190	-1	-1	-1	-1	90	-1	-1	-1	-1	-1	-1	-1	-1	-1	-1	-1	-1	-1
37	-1	-1	-1	-1	-1	-1	-1	-1	-1	-1	78	-1	-1	190	-1	-1	-1	-1	-1	-1	-1
38	-1	90	-1	-1	-1	126	-1	-1	-1	-1	234	-1	-1	-1	-1	-1	-1	-1	-1	-1	-1
39	164	-1	-1	-1	-1	-1	-1	134	-1	-1	-1	-1	200	-1	-1	-1	-1	-1	-1	-1	-1
40	-1	-1	239	-1	-1	-1	-1	-1	-1	-1	17	-1	-1	63	-1	-1	-1	-1	-1	0	-1
41	-1	99	-1	-1	-1	94	-1	-1	-1	-1	-1	181	-1	-1	-1	-1	-1	-1	-1	-1	0

FIG. 3b-6

30b-7

	0	1	2	3	4	5	6	7	8	9	10	11	12	13	14	15	16	17	18	50	51
0	191	100	49	135	-1	-1	36	-1	-1	80	0	0	-1	-1	-1	-1	-1	-1	-1	-1	-1
1	119	-1	-1	26	219	57	199	89	25	42	-1	0	0	-1	-1	-1	-1	-1	-1	-1	-1
2	19	25	-1	6	131	-1	-1	-1	55	-1	1	-1	0	0	-1	-1	-1	-1	-1	-1	-1
3	-1	103	90	-1	140	4	38	53	29	36	0	-1	-1	0	-1	-1	-1	-1	-1	-1	-1
4	172	35	-1	-1	-1	-1	-1	-1	-1	-1	17	-1	-1	0	-1	-1	-1	-1	-1	-1	-1
5	96	121	-1	-1	-1	80	-1	207	-1	-1	-1	183	-1	-1	-1	0	-1	-1	-1	-1	-1
6	6	-1	-1	-1	-1	143	-1	86	-1	15	-1	98	-1	-1	-1	-1	0	-1	-1	-1	-1
7	-1	16	-1	-1	-1	18	-1	28	-1	-1	-1	69	-1	50	-1	-1	-1	0	-1	-1	-1
8	17	19	-1	-1	-1	-1	-1	-1	-1	-1	-1	77	-1	-1	-1	-1	-1	0	-1	-1	
9	-1	207	-1	-1	-1	-1	-1	-1	199	-1	87	39	-1	-1	-1	-1	-1	-1	-1	-1	-1
10	34	202	-1	-1	-1	-1	29	174	-1	-1	-1	-1	-1	-1	-1	-1	-1	-1	-1	-1	-1
11	176	-1	-1	-1	-1	-1	-1	19	222	-1	-1	-1	-1	201	-1	-1	-1	-1	-1	-1	-1
12	-1	33	-1	100	-1	-1	-1	-1	-1	-1	-1	55	-1	-1	-1	-1	-1	-1	-1	-1	-1
13	3	155	-1	-1	-1	-1	-1	-1	114	-1	-1	-1	-1	195	-1	-1	-1	-1	-1	-1	-1
14	-1	168	-1	-1	-1	-1	14	-1	-1	-1	-1	198	-1	14	-1	-1	-1	-1	-1	-1	-1
15	77	-1	-1	-1	-1	-1	-1	-1	-1	-1	81	212	-1	-1	-1	-1	-1	-1	-1	-1	-1
16	-1	26	-1	-1	-1	-1	-1	-1	-1	31	-1	193	20	-1	-1	-1	-1	-1	-1	-1	-1
17	-1	40	-1	-1	-1	89	-1	-1	-1	-1	-1	27	194	-1	-1	-1	-1	-1	-1	-1	-1
18	33	-1	-1	-1	-1	-1	132	194	-1	-1	-1	-1	-1	-1	-1	-1	-1	-1	-1	-1	-1
19	148	170	-1	-1	-1	-1	-1	-1	-1	-1	170	-1	-1	-1	-1	-1	-1	-1	-1	-1	-1
20	-1	23	-1	-1	182	-1	-1	-1	-1	-1	-1	212	-1	-1	-1	-1	-1	-1	-1	-1	-1
21	19	-1	-1	-1	-1	-1	-1	-1	122	-1	-1	-1	-1	66	-1	-1	-1	-1	-1	-1	-1
22	-1	0	31	-1	-1	-1	-1	-1	-1	-1	-1	-1	-1	-1	-1	-1	-1	-1	-1	-1	-1
23	49	-1	-1	134	-1	16	-1	-1	-1	-1	-1	-1	-1	-1	-1	-1	-1	-1	-1	-1	-1
24	-1	64	72	-1	-1	-1	-1	-1	-1	180	-1	-1	-1	-1	-1	-1	-1	-1	-1	-1	-1
25	221	-1	-1	-1	-1	33	-1	-1	-1	-1	-1	-1	-1	-1	-1	-1	-1	-1	-1	-1	-1
26	-1	-1	27	-1	-1	-1	-1	87	-1	-1	-1	-1	157	187	-1	-1	-1	-1	-1	-1	-1
27	201	-1	-1	-1	-1	-1	72	-1	-1	-1	-1	-1	-1	-1	-1	-1	-1	-1	-1	-1	-1
28	-1	219	202	-1	-1	68	-1	-1	-1	-1	-1	-1	-1	-1	-1	-1	-1	-1	-1	-1	-1
29	153	-1	-1	-1	196	-1	-1	-1	-1	-1	-1	-1	-1	-1	-1	-1	-1	-1	-1	-1	-1
30	-1	-1	68	-1	-1	217	-1	131	-1	93	-1	-1	-1	-1	-1	-1	-1	-1	-1	-1	-1
31	-1	193	-1	-1	-1	-1	-1	-1	-1	-1	-1	-1	-1	141	-1	-1	-1	-1	-1	-1	-1
32	82	-1	-1	-1	-1	138	-1	-1	-1	-1	-1	-1	204	-1	-1	-1	-1	-1	-1	-1	-1
33	-1	-1	142	-1	-1	-1	-1	53	-1	-1	144	-1	-1	-1	-1	-1	-1	-1	-1	-1	-1
34	79	-1	-1	-1	-1	-1	-1	-1	-1	-1	-1	-1	93	54	-1	-1	-1	-1	-1	-1	-1
35	-1	188	-1	-1	-1	135	-1	-1	-1	-1	-1	205	-1	-1	-1	-1	-1	-1	-1	-1	-1
36	177	-1	124	-1	-1	-1	-1	66	-1	-1	-1	-1	-1	-1	-1	-1	-1	-1	-1	-1	-1
37	-1	-1	-1	-1	-1	-1	-1	-1	-1	-1	57	-1	-1	62	-1	-1	-1	-1	-1	-1	-1
38	-1	45	-1	-1	-1	97	-1	-1	-1	-1	-1	150	-1	-1	-1	-1	-1	-1	-1	-1	-1
39	105	-1	-1	-1	-1	-1	-1	10	-1	-1	-1	-1	223	-1	-1	-1	-1	-1	-1	-1	-1
40	-1	-1	200	-1	-1	-1	-1	-1	-1	-1	129	-1	-1	216	-1	-1	-1	-1	-1	0	-1
41	-1	208	-1	-1	-1	32	-1	-1	-1	-1	-1	53	-1	-1	-1	-1	-1	-1	-1	-1	0

FIG. 3b-7

30b-8

	0	1	2	3	4	5	6	7	8	9	10	11	12	13	14	15	16	17	18	50	51
0	153	19	47	79	-1	-1	19	-1	-1	90	0	0	-1	-1	-1	-1	-1	-1	-1	-1	-1
1	58	-1	-1	201	157	100	42	46	15	19	-1	0	0	-1	-1	-1	-1	-1	-1	-1	-1
2	48	160	-1	172	169	-1	-1	-1	169	-1	1	-1	0	0	-1	-1	-1	-1	-1	-1	-1
3	-1	38	2	-1	196	50	192	81	98	85	0	-1	-1	0	-1	-1	-1	-1	-1	-1	-1
4	169	94	-1	-1	-1	-1	-1	-1	-1	-1	-1	8	-1	-1	0	-1	-1	-1	-1	-1	-1
5	20	76	-1	-1	-1	102	-1	136	-1	-1	-1	186	-1	-1	-1	0	-1	-1	-1	-1	-1
6	121	-1	-1	-1	-1	160	-1	180	-1	161	-1	172	-1	-1	-1	-1	0	-1	-1	-1	-1
7	-1	104	-1	-1	-1	109	-1	109	-1	-1	-1	106	-1	81	-1	-1	-1	0	-1	-1	-1
8	107	133	-1	-1	-1	-1	-1	-1	-1	-1	-1	-1	197	-1	-1	-1	-1	-1	0	-1	-1
9	-1	49	-1	-1	-1	-1	-1	-1	4	-1	164	128	-1	-1	-1	-1	-1	-1	-1	-1	-1
10	165	172	-1	-1	-1	-1	11	148	-1	-1	-1	-1	-1	-1	-1	-1	-1	-1	-1	-1	-1
11	85	-1	-1	-1	-1	-1	-1	111	-1	161	-1	-1	-1	113	-1	-1	-1	-1	-1	-1	-1
12	-1	84	-1	128	-1	-1	-1	-1	-1	-1	-1	198	-1	-1	-1	-1	-1	-1	-1	-1	-1
13	54	129	-1	-1	-1	-1	-1	-1	10	-1	-1	-1	-1	59	-1	-1	-1	-1	-1	-1	-1
14	-1	165	-1	-1	-1	-1	77	-1	-1	-1	-1	125	-1	131	-1	-1	-1	-1	-1	-1	-1
15	74	-1	-1	-1	-1	-1	-1	-1	-1	-1	72	48	-1	-1	-1	-1	-1	-1	-1	-1	-1
16	-1	160	-1	-1	-1	-1	-1	-1	-1	134	-1	194	93	-1	-1	-1	-1	-1	-1	-1	-1
17	-1	194	-1	-1	-1	78	-1	-1	-1	-1	-1	158	91	-1	-1	-1	-1	-1	-1	-1	-1
18	193	-1	-1	-1	-1	-1	19	14	-1	-1	-1	-1	-1	-1	-1	-1	-1	-1	-1	-1	-1
19	71	134	-1	-1	-1	-1	-1	-1	-1	-1	39	-1	-1	-1	-1	-1	-1	-1	-1	-1	-1
20	-1	5	-1	-1	49	-1	-1	-1	-1	-1	-1	159	-1	-1	-1	-1	-1	-1	-1	-1	-1
21	61	-1	-1	-1	-1	-1	-1	-1	48	-1	-1	-1	-1	82	-1	-1	-1	-1	-1	-1	-1
22	-1	162	39	-1	-1	-1	-1	-1	-1	-1	-1	-1	-1	-1	-1	-1	-1	-1	-1	-1	-1
23	37	-1	-1	201	-1	174	-1	-1	-1	-1	-1	-1	-1	-1	-1	-1	-1	-1	-1	-1	-1
24	-1	191	176	-1	-1	-1	-1	-1	-1	178	-1	-1	-1	-1	-1	-1	-1	-1	-1	-1	-1
25	191	-1	-1	-1	-1	9	-1	-1	-1	-1	-1	-1	-1	-1	-1	-1	-1	-1	-1	-1	-1
26	-1	-1	94	-1	-1	-1	-1	83	-1	-1	-1	-1	142	198	-1	-1	-1	-1	-1	-1	-1
27	188	-1	-1	-1	-1	-1	176	-1	-1	-1	-1	-1	-1	-1	-1	-1	-1	-1	-1	-1	-1
28	-1	44	68	-1	-1	33	-1	-1	-1	-1	-1	-1	-1	-1	-1	-1	-1	-1	-1	-1	-1
29	10	-1	-1	-1	91	-1	-1	-1	-1	-1	-1	-1	-1	-1	-1	-1	-1	-1	-1	-1	-1
30	-1	-1	62	-1	-1	17	-1	135	-1	39	-1	-1	-1	-1	-1	-1	-1	-1	-1	-1	-1
31	-1	187	-1	-1	-1	-1	-1	-1	-1	-1	-1	-1	-1	58	-1	-1	-1	-1	-1	-1	-1
32	166	-1	-1	-1	-1	166	-1	-1	-1	-1	-1	-1	191	-1	-1	-1	-1	-1	-1	-1	-1
33	-1	-1	126	-1	-1	-1	-1	73	-1	-1	153	-1	-1	-1	-1	-1	-1	-1	-1	-1	-1
34	140	-1	-1	-1	-1	-1	-1	-1	-1	-1	-1	97	180	-1	-1	-1	-1	-1	-1	-1	-1
35	-1	198	-1	-1	-1	69	-1	-1	-1	-1	-1	202	-1	-1	-1	-1	-1	-1	-1	-1	-1
36	45	-1	30	-1	-1	-1	-1	134	-1	-1	-1	-1	-1	-1	-1	-1	-1	-1	-1	-1	-1
37	-1	-1	-1	-1	-1	-1	-1	-1	-1	-1	162	-1	-1	170	-1	-1	-1	-1	-1	-1	-1
38	-1	28	-1	-1	-1	109	-1	-1	-1	-1	-1	198	-1	-1	-1	-1	-1	-1	-1	-1	-1
39	51	-1	-1	-1	-1	-1	-1	44	-1	-1	-1	-1	82	-1	-1	-1	-1	-1	-1	-1	-1
40	-1	-1	157	-1	-1	-1	-1	-1	-1	-1	47	-1	-1	96	-1	-1	-1	-1	-1	0	-1
41	-1	142	-1	-1	-1	58	-1	-1	-1	-1	-1	73	-1	-1	-1	-1	-1	-1	-1	-1	0

FIG. 3b-8

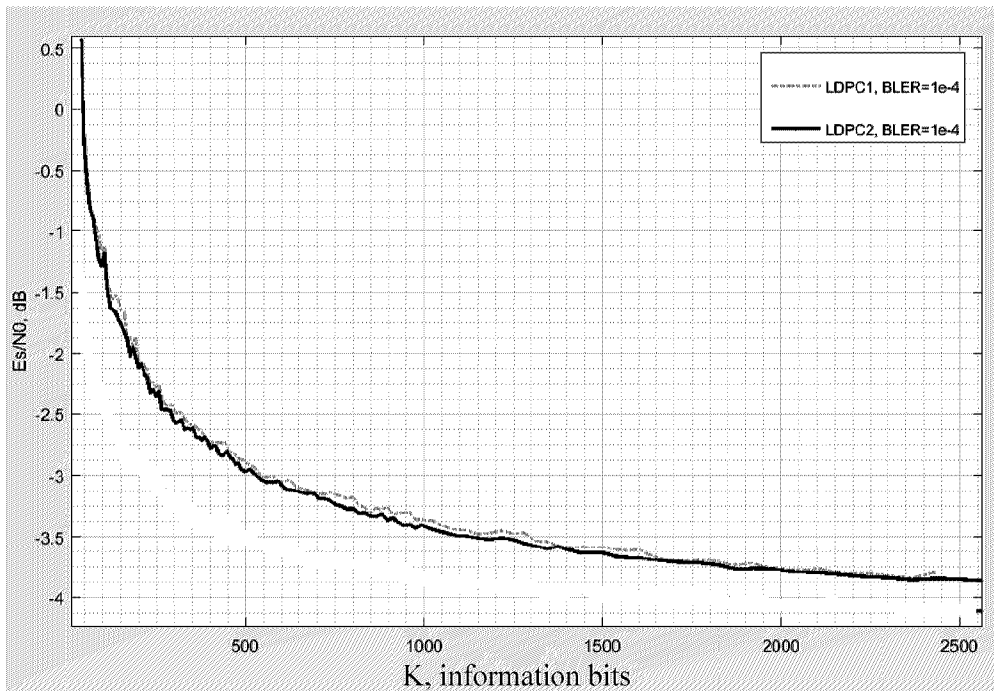

FIG. 4

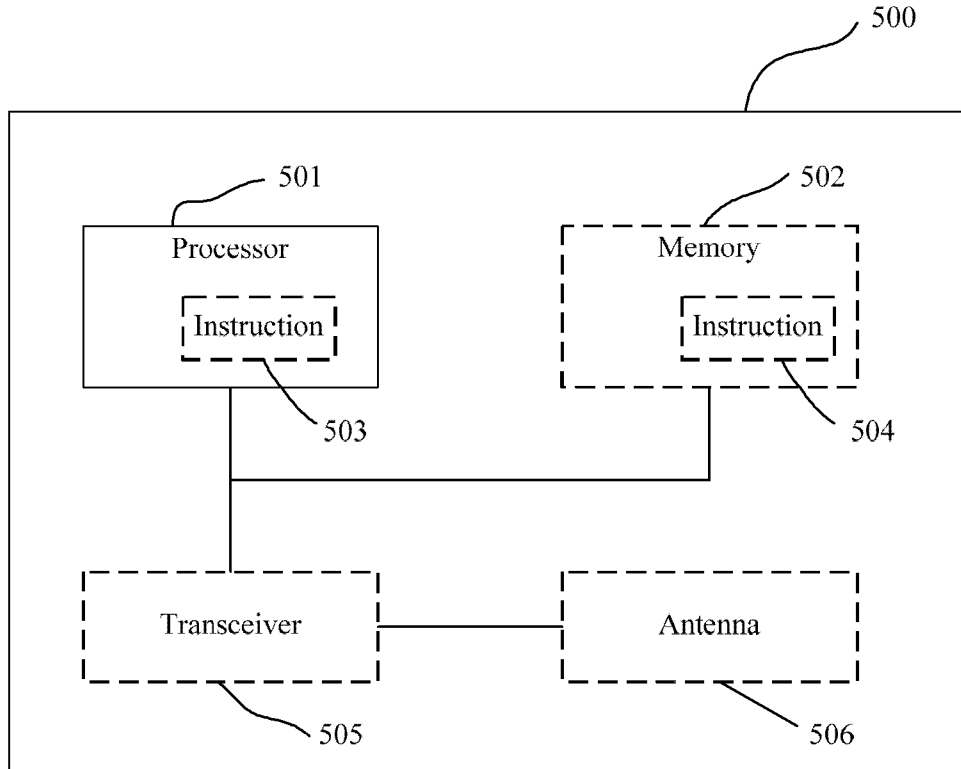

FIG. 5

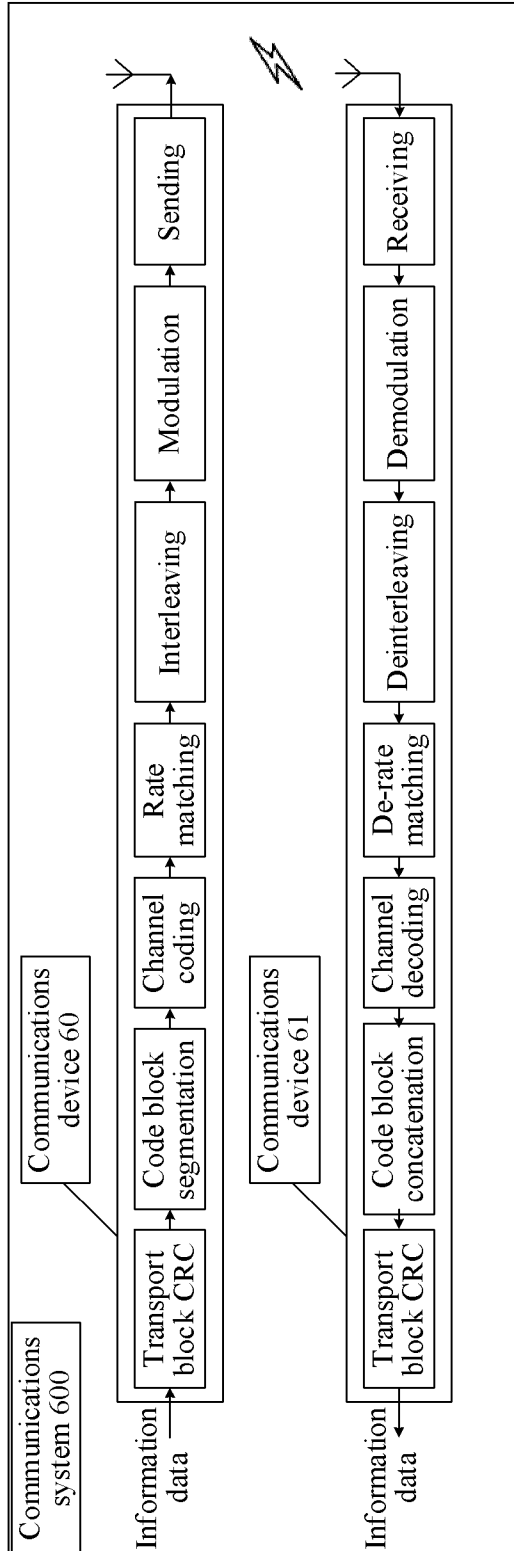

FIG. 6

