

June 28, 1949.

G. SAUER

2,474,331

SEWING MACHINE UNIT

Filed June 29, 1945

7 Sheets-Sheet 1

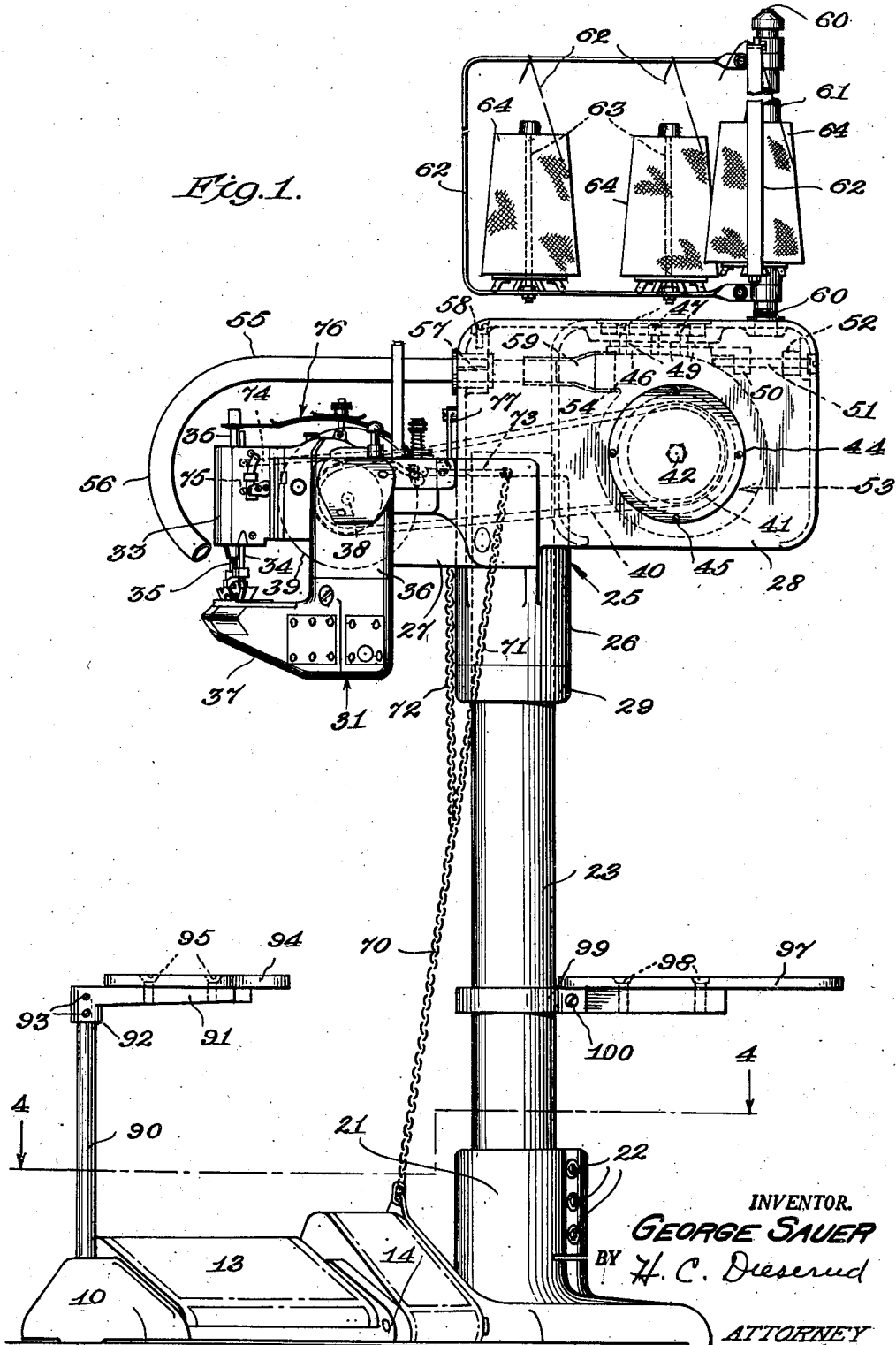

June 28, 1949.

G. SAUER

2,474,331

SEWING MACHINE UNIT

Filed June 29, 1945

7 Sheets-Sheet 2

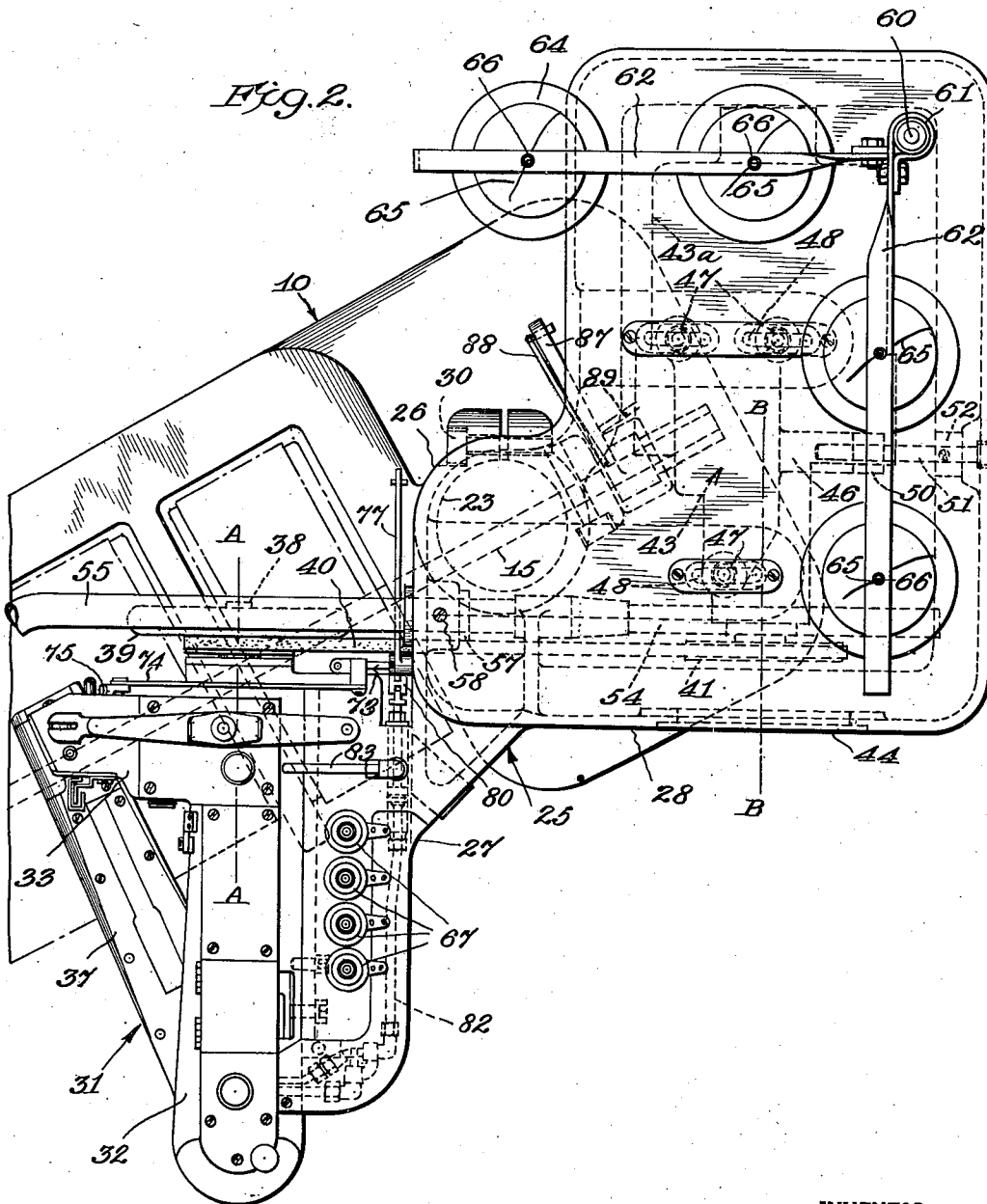

INVENTOR.  
**GEORGE SAUER**  
BY *H. C. Oesperud*  
ATTORNEY

June 28, 1949.

G. SAUER

2,474,331

SEWING MACHINE UNIT

Filed June 29, 1945

7 Sheets-Sheet 3

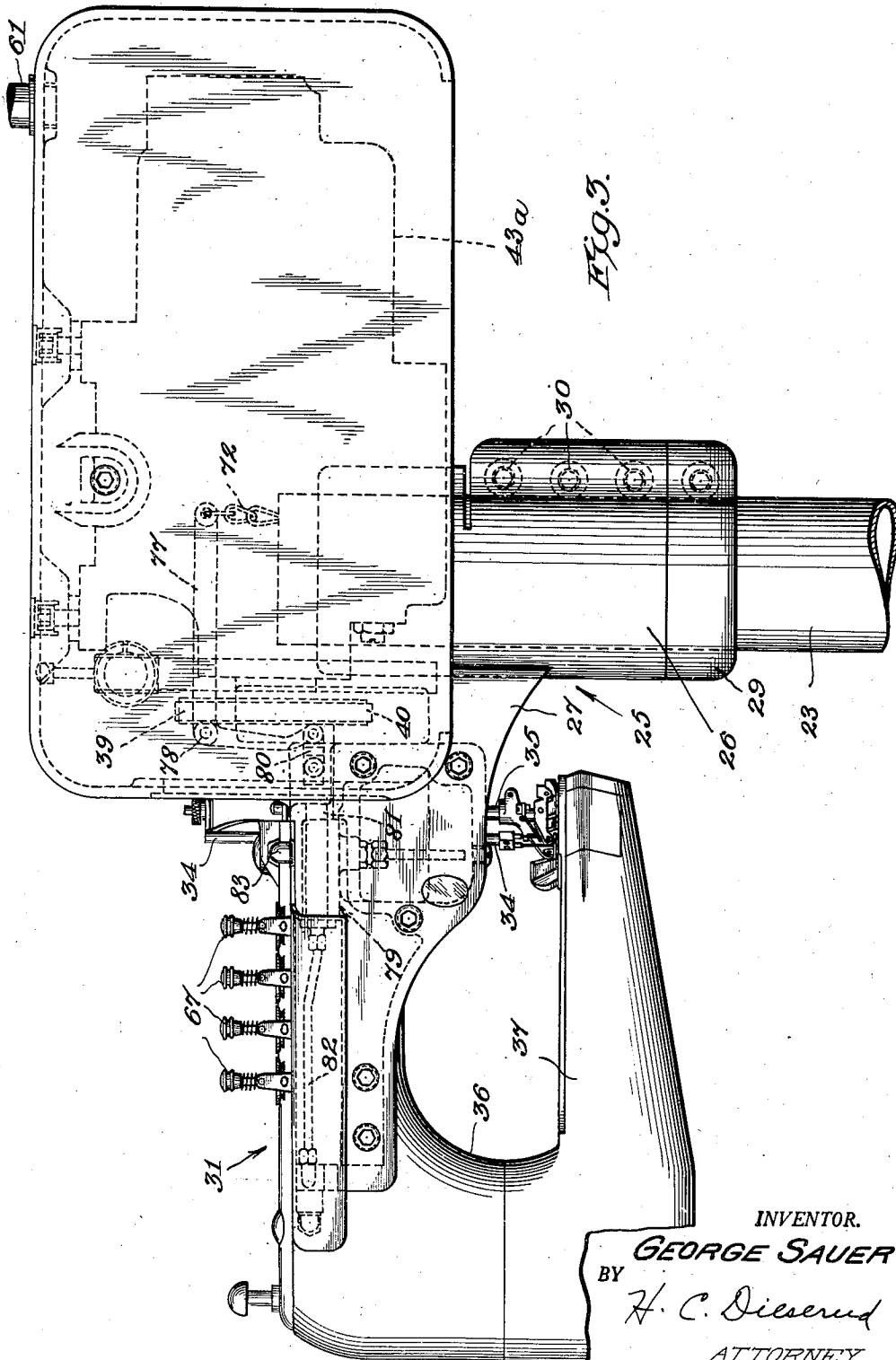

Fig. 5.

INVENTOR.

GEORGE SAUER

BY

H. C. Dilsenrud

ATTORNEY



June 28, 1949.

G. SAUER

2,474,331

SEWING MACHINE UNIT

Filed June 29, 1945

7 Sheets-Sheet 5

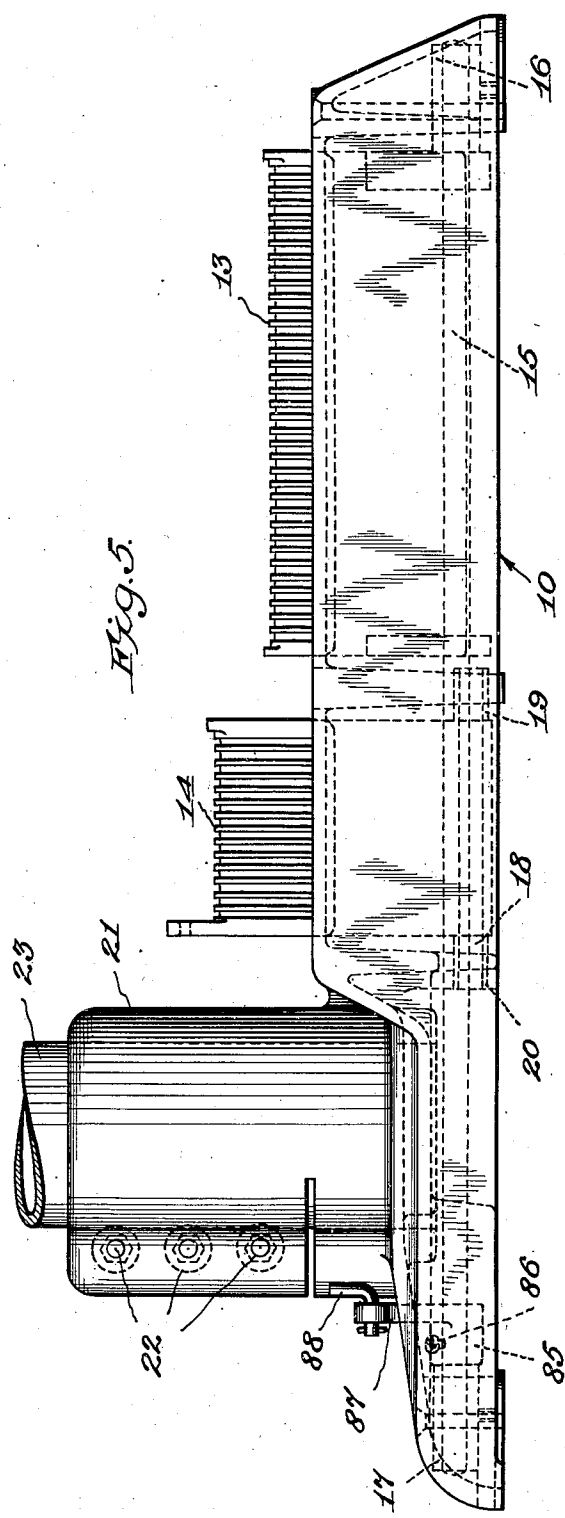

Fig. 5.

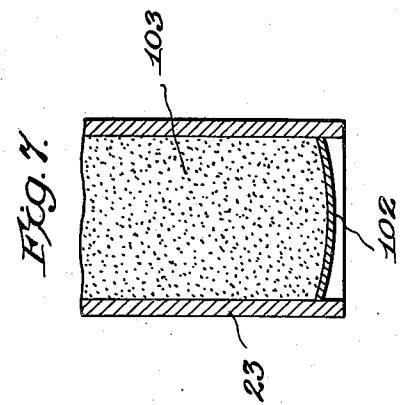

Fig. 7.

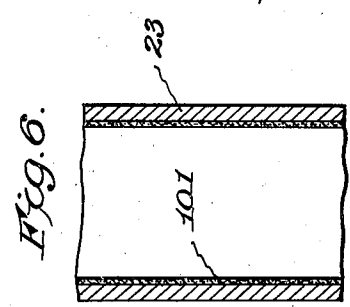

Fig. 6.

INVENTOR.  
**GEORGE SAUER**  
BY  
*H. C. Dilsner*  
ATTORNEY

June 28, 1949.

G. SAUER  
SEWING MACHINE UNIT

2,474,331

Filed June 29, 1945

7 Sheets-Sheet 6

Fig. 8.

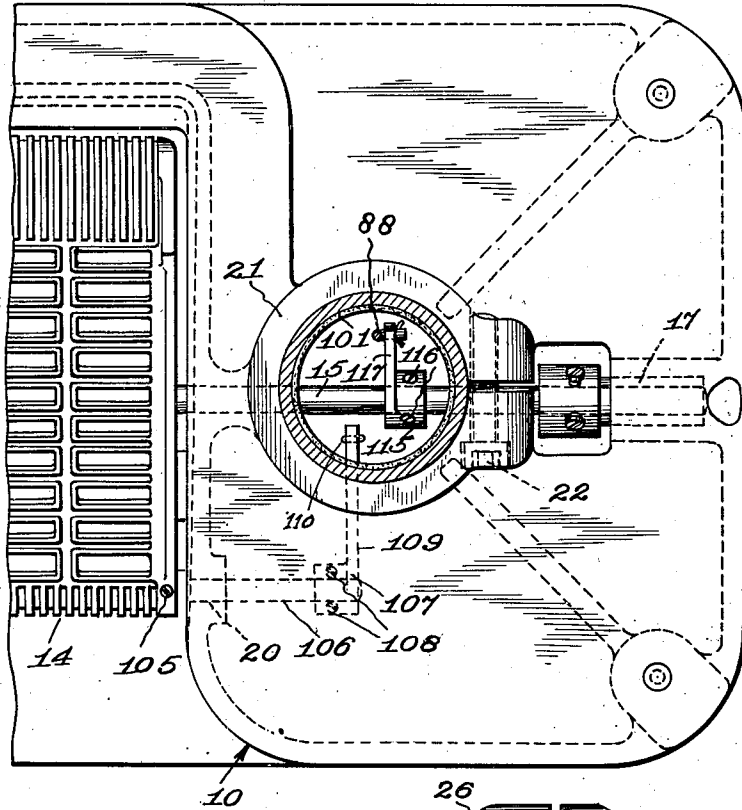
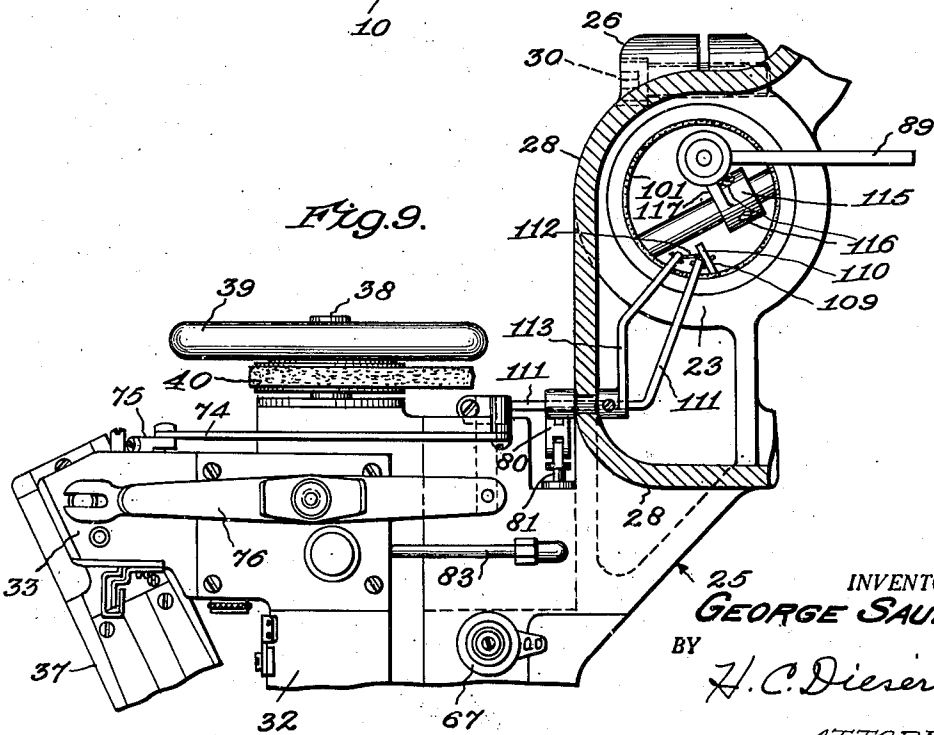

Fig. 9.



INVENTOR.  
**GEORGE SAUER**  
BY  
*H. C. Dierdorf*  
ATTORNEY



# UNITED STATES PATENT OFFICE

2,474,331

## SEWING MACHINE UNIT

George Sauer, Berwyn, Ill., assignor to Union Special Machine Company, Chicago, Ill., a corporation of Illinois

Application June 29, 1945, Serial No. 602,198

11 Claims. (Cl. 112—258)

1

This invention relates to an improved sewing machine unit, and in one of its more specific aspects, to such a unit wherein a sewing machine and a power transmitting means, including an electric motor, are supported in spaced relation on an upright standard.

One of the objects of this invention is to provide a sewing machine unit, including a sewing machine and power transmitting means, including an individual motor, on a portable support in a compact and convenient arrangement, and in such a manner that the operator is permitted maximum freedom of his hands and arms in manipulating and sewing various articles.

Another object of the invention is to provide a sewing machine unit of the character indicated wherein the sewing machine and the driving unit are disposed on opposite sides of an upright standard, in spaced balanced relation, and so arranged that the sewing machine is disposed substantially wholly intermediate the standard and the position normally assumed by an operator of the machine, while the motor forming the power source for the driving unit is disposed on the opposite side of the standard. As a result, the operator is subjected to a minimum of objectional heat developed by the motor in the course of its normal operation. Moreover, this arrangement is such that the standard is in advance of the arc of movement of the hands of the operator in manipulating the work, thus insuring maximum freedom of action.

Another object of this invention is to provide a sewing machine unit of the type indicated that is capable of utilizing known types of sewing machines for stitching tubular articles, such as overalls and the like.

Another object of the invention has been to provide a sewing machine unit, including a sewing machine proper and various operating devices disposed on opposite sides and in spaced relation to an upright support which is so constructed as to effectively reduce noises incident to the operation of the unit as a whole.

Another object of this invention is to provide a sewing machine unit of the character indicated having direct operating connections from suitable foot-actuated control treadles to various devices, such as a power transmitting unit, a presser bar, and an oil pump.

A further object of the invention is to provide a sewing machine unit, including a substantially vertical standard, a sewing machine and power transmitting means disposed on opposite sides of the standard and in spaced relation thereto, foot

2

control means for actuating various devices of the unit, and work supporting platforms, all arranged in suitable predetermined relation to obtain a balanced structure that may be readily and advantageously employed in carrying out various stitching operations.

A still further object of the invention is to provide a sewing machine unit of the character indicated that is relatively simple and rugged in construction and that may be readily moved from place to place.

The sewing machine unit of this invention involves, in its basic aspects, a base having a substantially vertical, hollow tubular standard extending upwardly therefrom. A support is secured to the upper end of the standard and carries a sewing machine unit of desired type to one side of the standard and a housing to the other side of the standard. Within the housing is a power transmitting unit, including a motor having a driving shaft for imparting rotation to a parallel main shaft of the sewing machine through the medium of a short belt connection. The sewing machine is disposed between the standard and the position normally assumed by the operator during operation, but in such relation as to provide maximum freedom for the manipulation of the work within a minimum overall space requirement, while the motor of the power transmitting unit is disposed remotely from such position of the operator. Also within the housing is a blower communicating with a conduit extending through a wall of the housing and over the top of the sewing machine, this conduit having a gooseneck portion for directing a stream of air under pressure in a manner to cool the needles of the machine and keep the work support clean. Various control devices are contained within the housing, including a lever for actuating the presser bar and a lever for controlling the operation of the power transmitting unit to place the same in and out of service as desired. Additionally, a pump arrangement is provided for transmitting lubricating oil to various devices within the sewing machine. Suitable foot treadle connections provide ready control of the presser bar, the lubricating oil pump, and the power transmitting mechanism, as will be hereinafter more fully described.

Noises incident to the operation of the unit are successfully minimized by providing suitable insulation within the hollow tubular standard. Such insulation may be in the form of a coating of a sound absorbing material on the inner surface of the hollow standard, or may be in the nature of a

mass of sound absorbing material substantially filling the entire length of the standard.

In the seaming of certain garments, it is often necessary that a left-hand member be joined to a right-hand member. To facilitate such an operation by the practice of this invention, I provide a swingable platform supported above the base for carrying a supply of left-hand members and a platform carried by the standard for holding a supply of right-hand members. This results in a convenient arrangement whereby the operator may readily pick up a member from each of the platforms and sew them on the sewing machine of the unit without necessitating stooping over or reaching into a basket or other source of supply, either to one side of or behind the operator.

With the above and other objects in view, the invention comprises the devices, combinations and arrangements of parts set forth in the following detailed description and illustrated in the annexed drawings of preferred embodiments of the invention, from which the several features of the invention, together with the advantages attainable thereby, will be readily understood by persons skilled in the art.

In the drawings:

Figure 1 is an end elevational view of the sewing machine unit viewed from substantially the normal operating position;

Figure 2 is a top plan view of the machine of Figure 1 in enlargement with certain parts omitted;

Figure 3 is an enlarged side elevational view of the upper part of the machine of Figure 1;

Figure 4 is an enlarged horizontal, sectional view taken along line 4—4 of Figure 1;

Figure 5 is a rear elevational view of the parts shown in Figure 4;

Figure 6 is a central vertical cross-sectional view of a portion of the hollow tubular standard or post in enlargement, illustrating one type of sound dampening or reducing means therein;

Figure 7 is a view similar to Figure 6 illustrating another type of sound dampening or reducing means within the hollow tubular standard;

Figure 8 is a partial view, similar to Figure 4, of a modification of the invention;

Figure 9 is an enlarged fragmentary plan view, partly in horizontal cross section, of a sewing machine unit embodying certain modifications of the invention;

Figure 10 is a side elevation view of another modification of the sewing machine unit;

Figure 11 is a top plan view of Figure 10; and

Figure 12 is a side elevation view of still another embodiment of the sewing machine unit of this invention.

Referring now to the drawings wherein like reference characters denote corresponding parts throughout the several views, and more particularly to Figures 1, 4 and 5 thereof, the base of the sewing machine unit is generally indicated by numeral 10 and is formed with a pair of openings 11 and 12 to accommodate foot treadles 13 and 14, respectively. Treadle 13 is affixed to a rock shaft 15 that is suitably journaled at opposite ends in a pair of bearing sleeves or the like 16 and 17, while treadle 14 is mounted for tilting movement about the axis of a stub shaft 18 that has its opposite ends disposed in bearing sleeves or the like 19 and 20 in the base 10. An upstanding split sleeve 21 is preferably formed integral with the base and is adapted to receive and securely clamp, by means of a series of screws

22, the lower portion of a substantially vertical hollow tubular standard or post 23.

A bracket support 25 is provided with a depending split sleeve 26 that embraces the upper end portion of post 23, a bracket member 27 extending to one side of post 23, and a housing 28, that is preferably rectangular and open at the bottom, extending to the other side of post 23. A collar 29 is vertically adjustable along post 23 for varying the vertical position of bracket support 25 and the devices carried thereby. Split sleeve 26 may be maintained in any desired angular and vertical position with respect to post 23 by means of screws 30.

A sewing machine 31 is carried by bracket support 25 to the left side and forwardly of post 23, as viewed in Figures 1 and 2. This is accomplished by rigidly attaching the outer end of bracket member 27 to the upper frame 32 of the sewing machine. The sewing machine may be of any desired construction but, as illustrated in the drawings, is preferably of the type disclosed in Christensen et al. Patent No. 1,741,095, granted December 24, 1929. The portion of the frame disclosed in that patent, which extends into a base or standard by which the machine is supported from a table or the like, is simply eliminated in the instant arrangement, as will be readily observed from an inspection of Figures 1 and 2, thereby providing for greater freedom of lateral movement of the operator's hands and arms in the course of the operation of the machine. It will be noted further that the sewing machine is spaced from both base 10 and post 23, resulting in adequate clearance and ready access to the various stitch-forming and control devices which will be identified hereinafter.

The details of the interior mechanism of sewing machine 31 form no part of the present invention, and hence it is not deemed necessary that this construction be described. It is considered sufficient, for the purposes of this description, to identify a number of the essential elements and devices of the sewing machine shown in the drawings. The upper frame 32 of the machine has a needle head 33 suitably attached thereto and extending laterally of its forward end. The needle head has a needle bar 34 and a presser bar 35, both of which are mounted for vertical movement in the usual manner. Depending from the rearward end of upper frame 32 is a hollow member 36 to which is attached a work supporting arm or member 37 extending forwardly below, but at an acute angle to, the upper frame member. As is best shown in Figures 1 and 2, the free end of the work supporting arm is located beneath the needle head. It is provided with necessary work feeding devices, loopers or other stitch-forming means (not shown), adapted to cooperate with the needles carried by needle bar 34. Reference may be had to the above mentioned Christensen et al. patent for further details as to the construction and operation of the stitch-forming and work-feeding devices and the operating means therefor.

Disposed within and projecting beyond the forward end of upper frame 32 is a rotary main shaft 38, whose axis is indicated by line A—A (Figure 2) for actuating needle bar 34 and the stitch-forming and work-feeding devices of the sewing machine. This shaft has a combined handwheel and pulley 39 secured to its projecting end. It is recommended that the handwheel be substantially larger in diameter than those customarily employed with similar sewing machines. By pro-

viding such a larger handwheel and by having the machine frame constructed and arranged as illustrated, the lower portion of the handwheel may be readily grasped and manually actuated by the operator by a forward movement of the right hand without necessitating the withdrawal of the entire arm from its general operating position, as is necessary in the case of the machine frame disclosed in the earlier mentioned Christensen et al. patent. This will be readily apparent from an inspection of Figure 1. The combined handwheel and pulley is connected by a relatively short open belt 40 with a drive pulley 41 secured to the forward end of a driving shaft 42 of a power transmitting mechanism 43 that includes a motor 43a, and that is contained within housing 28. The power transmitting unit may, for example, be of the type disclosed in the patent to Peets et al. No. 2,004,055, granted June 4, 1935. The axis of driving shaft 42 is denoted by line B—B (Figure 2), the same being parallel to axis A—A of main shaft 33 of the sewing machine. With the construction just described, and as is illustrated in Figures 1 and 2, the sewing machine 31 is arranged wholly forwardly of tubular post 23, while motor 43a of the power transmitting unit is positioned rearwardly of tubular post 23 and remotely from the position normally assumed by the operator of the unit, with the result that the operator is subjected to a minimum amount of objectionable frictional heat developed by motor 43a in the course of operation.

A cover plate 44 is detachably mounted on the forward end of the housing by a series of screws 45 to permit of ready access to drive pulley 41 when it is desired to attend to replacements, repairs or adjustments thereof. The power transmitting mechanism is contained and suspended within housing 28 through the cooperation of a bracket 46 and a series of screws 47 that project through slots 48 in the top wall of the housing. Interposed between the under surface of the top of the housing and bracket 46 are a plurality of vibration insulators 49 composed of a suitable material, such as natural or synthetic rubber or the like. Bracket 46 includes a depending arm 50 that is tapped to receive an adjusting screw 51 which is operated from the exterior of the housing by a screw driver or other suitable tool, and which is constrained against axial movement by a collar 52. Through the coaction of bracket 46, suspending screws 47 and adjusting screw 51, the position of power transmitting mechanism 43 within housing 28 may be readily varied, as required, to obtain proper tensioning of belt 40. Lateral shifting of the bracket 46 in the manner indicated is permitted by the elongated slots 48.

Also disposed within housing 28 and actuated by power transmitting mechanism 43 is a blower assembly 53 having a discharge outlet 54 (Figure 1). A tube 55 having an end portion bent in the shape of a gooseneck 56 extends through a boss formed in a side wall of housing 28 and is clamped thereto by means of a split sleeve 57 which is tightened by a set screw 58 accessible from the exterior of the housing. Communication between the end of tube 55 within housing 28 and blower outlet 54 is established by a flexible tubular connector 59 formed of rubber or a suitable plastic or the like. In operation, a continuous stream of air under pressure discharged from blower assembly 53 through outlet 54, flows through flexible connector 59, through tube 55, and is then directed by gooseneck 56 to the region of the needles carried by needle bar 34 for

the dual purpose of cooling the same and blowing away lint and other foreign particles that may be present. The construction and arrangement with respect to this phase of the invention may advantageously be similar to that disclosed in the application of Charles F. Rubel Ser. No. 433,740, filed March 7, 1942, now Patent No. 2,423,996, July 15, 1947.

Power may be supplied to the motor of the power transmitting unit by an electric cable 60 which extends downwardly from an overhead line (not shown) through the hollow interior of a vertical conduit 61 that is threadedly coupled at its lower end to the top wall of housing 28. Conduit 61 also serves as a support for a pair of C-shaped frame members 62 that are positioned at right angles to each other, and that may be of the type disclosed in pending application of Clarence C. Smith Ser. No. 513,504, filed December 9, 1943, now Patent No. 2,430,832, November 11, 1947. Each C-shaped frame carries a pair of vertical spindles 63 that extend through and support spools 64 of thread 65. Individual strands of thread are passed through corresponding guide openings 66 in the upper portion of the frame members, to thread tensioning devices 67, and thence to the sewing machine needles and loopers.

Attached to a rearward corner of treadle 14 and extending upwardly therefrom is a chain or other type of flexible connector 70 which is connected to a pair of branch chains 71 and 72. Branch chain 71 is secured at its upper end to a presser bar actuating lever 73 (Figures 1 and 2), which cooperates with a link 74, a lever 75, and devices (not shown) within needle head 33, to move the presser bar 35 upwardly, when treadle 14 is depressed, against the action of a spring member 76 that normally urges and maintains the presser bar in downward position. The mechanism for this purpose within the needle head may be similar to that shown in Christensen et al. Patent No. 1,773,028, granted August 12, 1930. Upon release of pressure on foot treadle 14, the parts return to the relative positions illustrated in Figure 1, due primarily to the action of spring member 76.

The actuation of foot treadle 14 also operates a pumping system for lubricating various parts within the sewing machine by a mechanism that will now be described, having particular reference to Figures 1, 2 and 3. In this connection, there are provided a bell crank 77, which is pivoted at 78 and has one arm connected with the branch chain 72, and a double-acting pump 79 that may be of the type disclosed in Clarence C. Smith application Ser. No. 541,902, filed June 24, 1944, now Patent No. 2,430,370, November 4, 1947. A link 80 may connect the other end of bell crank 77 to a reciprocating piston 81 of a pump cooperating with a plurality of conduits, such as those indicated at 82 and 83, for transmitting lubricating oil to the sewing machine parts. For further details as to the construction and operation of the double-acting pump, reference may be had to the above mentioned application of Clarence C. Smith. It suffices to point out that when foot treadle 14 is depressed, chain 70 and branch chain 72 are moved downwardly, urging bell crank 77 in a clockwise direction about pivot 78 (as viewed in Figure 3), thereby moving piston 81 toward the left and forcing lubricating oil through one of the conduits 82 and 83 to certain of the sewing machine devices, whereas upon release of the treadle the piston is moved in the opposite direction to lubricate other parts.

7

It is hence observed that upon depressing foot treadle 14, presser bar 35 is moved upwardly and simultaneously therewith lubricating oil is transmitted to various devices within the sewing machine.

Referring next to Figures 4 and 5, a sleeve 85 is mounted on rock shaft 15 by screws 86 and carries a rock arm 87 which is coupled to a pitman rod 88 at its free end. The pitman rod extends generally upwardly and is secured at its upper end to a lever 89 (Figure 2) for operating the usual clutch (not shown) of the power transmitting mechanism whereby the latter may be readily placed in and out of service, as desired, by simply depressing foot treadle 13. If desired, branch chain 72 may be disconnected from the upper end of chain 70 and connected to pitman rod 88 to thereby actuate the double-acting pump mechanism in response to operating foot treadle 13.

As was indicated earlier herein, the seaming of certain garments, such as overalls and the like, by the sewing machine depicted in the drawings, requires the joining together of a left-hand member to a right-hand member. This operation is facilitated, in accordance with the invention, by equipping the unit with a pair of suitable platforms or trays as will now be described. Secured to the rearward left-hand corner of base 10 (Figures 1 and 4) and projecting substantially vertically therefrom, is a tubular post 90. A bracket arm 91, having a hollow sleeve-like portion 92 at one end, receives the upper end of post 90 and is adjustably secured thereto in desired vertical or angular relation by means of set screws 93. A platform or tray 94 is affixed to bracket arm 91 by screws 95 that are preferably counter-sunk to eliminate obstructions on the upper surface of the platform. A stack of left-hand members of the garment may be placed on platform 94 which is swingable to any desired angular position with respect to the base of the sewing machine unit. A second platform or tray 97 is similarly attached by screws 98 to a bracket arm 99 having one end portion so formed as to embrace post 23 and be clamped thereto by one or more screws 100. It will be apparent that platform 97 is vertically and angularly adjustable with respect to post 23. A stack of right-hand garment members may be placed on platform 97.

One of the features of this invention resides in the provision of means for reducing and dampening noises incident to the operation of the power transmitting mechanism 43, the sewing machine 31, and other devices of the unit. I have found that objectionable noises may be materially reduced by placing a coating or liner of sound absorbing material 101, such as natural or synthetic rubber, along the inner surface of tubular post 23, or by placing a closure 102 across the lower end of post 23 and substantially filling the interior of the post with a mass of solid sound absorbing material, such as sawdust or the like. If desired, post 23 may be provided with a liner 101 and then filled with sound absorbing material 103.

One modification of the sewing machine unit is illustrated in Figures 8 and 9, and contemplates locating the chains or other flexible control devices within hollow tubular standard 23, as distinguished from placing the same exterior of the post 23, as shown in Figures 1, 2 and 4. Referring to Figure 8, treadle 14 is affixed by one or more set screws 105 to its support shaft 106, which

8

extends into base 10 of the sewing machine unit. A sleeve 107 is attached to shaft 106 by set screws 108 and carries an arm 109 which projects into the region directly below post 23. A chain 110 is secured to the free end of lever 109 and to an end of a presser foot lifting lever 111 that cooperates with link 74, lever 75 and devices (not shown) within needle head 33 for moving the presser bar upwardly against the action of spring member 76 when treadle 14 is depressed in the same manner set forth in connection with the first described embodiment of the invention.

The lubricating pump is also actuated each time foot treadle 14 is depressed through a connection provided by a second chain 112 connected at its lower end to the free end of arm 109 or to a point on the chain 110 and at its other end to a bell crank 113 which is in turn coupled to pump piston 81 by a linkage 80. It will be observed that chains 110 and 112 both extend upwardly through the interior of hollow post 23.

A sleeve 115 is mounted on rock shaft 15 by screws 116 and carries a rock arm 117 which is coupled at its free end to the lower end of pitman rod 88. The pitman rod extends upwardly within the confines of post 23 and is secured at its upper end to lever 89 for operating the usual clutch (not shown) of the power transmitting mechanism whereby the power transmitting mechanism may readily be placed in and out of service as desired, by simply depressing foot treadle 13.

In the embodiment of the invention shown in Figures 10 and 11, housing 28, within which the power transmitting devices are contained, is disposed directly above and is mounted on the upper end of hollow post 23 and the sewing machine unit is connected thereto and extends laterally therefrom as illustrated. In this embodiment of the invention, the rotary main shaft 38 of the sewing machine unit is directly in line with the shaft of the motor 43a of the power transmitting mechanism and is driven by said motor through a clutch without the use of a belt.

In instances where it is desirable to have a belt drive between the motor and the main drive shaft of the sewing machine unit, the arrangement shown in Figure 12 may be employed. In this modification of the invention the motor and clutch unit is mounted at the upper end of the standard, as in Figure 11, while the sewing machine unit is suspended below and to one side of housing 28 by a bracket or frame member 120. Rotation of the shaft of motor 43a is transmitted to main shaft 38 of the sewing machine through drive pulley 41, belt 121, and combined handwheel and pulley 39. It will be noted that this particular arrangement permits of ready access to combined handwheel and pulley 39, full freedom of movement of the operator's hands, and excellent visibility in performing the stitching operations.

It will be understood that in either of the arrangements shown in Figures 10, 11 and 12 the control means of either Figures 1 to 5, or 8 and 9 may be employed.

It is believed that the objects, advantages, construction and operation of my present invention will be readily understood from the foregoing by persons skilled in the art. By reference to the drawings, outstanding advantages of the particular constructions and arrangements disclosed are the freedom of movement provided for the operator in the manipulation of the work and the comfort with which the operator may use the

9

machine. The first advantage is achieved by the particular relationship provided by the relative positions of the sewing machine, the electric transmitter unit, and the supporting pedestal. Work supporting arm 37 of the sewing machine is so disposed that the operator may swing his hands freely in arcs extending from the stitching point outwardly as far as desired, without interference with the pedestal or standard 23 or any other part. The second advantage is achieved by making the stitching point visible to the operator without the necessity of leaning to one side and also by locating the transmitter, with its driving motor, at some distance from the operator. It is to be borne in mind, however, that various changes in the forms of the invention herein illustrated and described may be resorted to without departing from the spirit of the invention or the scope of the appended claims.

I claim:

1. In a sewing machine unit, a base, a tubular post extending upwardly from said base, supporting means secured to said post above and in spaced relation to said base, a sewing machine carried by said supporting means to one side of said post and in spaced relation to said post and said base, power means carried by said supporting means to the opposite side of said post and in spaced relation to said post and said base for driving said sewing machine, and means within the post for dampening noises incident to the operation of the unit.

2. In a sewing machine unit, a base, a tubular post extending upwardly from said base, supporting means secured to said post above and in spaced relation to said base, a sewing machine carried by said supporting means to one side of said post and in spaced relation to said post and said base, power means carried by said supporting means to the opposite side of said post and in spaced relation to said post and said base for driving said sewing machine, and a liner of sound absorbing material along the inner surface of the post for dampening noises incident to the operation of the unit.

3. In a sewing machine unit, a base, a tubular post extending upwardly from said base, supporting means secured to said post above and in spaced relation to said base, a sewing machine carried by said supporting means to one side of said post and in spaced relation to said post and said base, power means carried by said supporting means to the opposite side of said post and in spaced relation to said post and said base for driving said sewing machine, and a mass of sound absorbing material substantially filling the interior of the post for effectively reducing noises incident to the operation of the unit.

4. In a sewing machine unit, a base, a rectilinear tubular post extending upwardly from said base, supporting means secured to said post above said base and adjustable axially and angularly with respect to said post, said supporting means including a bracket extending to one side of said post and a housing extending to the opposite side of said post, a sewing machine carried by the free end of said bracket to said one side of said post in spaced relation to said post and said base, and power transmitting means within and carried by said housing to said opposite side of said post in spaced relation to said base for driving said sewing machine.

5. In a sewing machine unit, a base, a rectilinear tubular post extending upwardly from said base, supporting means secured to said post above said base and adjustable axially and angularly

10

with respect to said post, said supporting means including a bracket extending to one side of said post and a housing extending to the opposite side of said post, a sewing machine carried by the free end of said bracket to said one side of said post in spaced relation to said post and said base, said sewing machine being disposed substantially wholly intermediate said post and the position normally assumed by the body of an operator of the machine, and power transmitting means within and carried by said housing for driving said sewing machine, said power transmitting means including a motor disposed remotely from said position of the operator of the sewing machine.

6. In a sewing machine unit, a base, a rectilinear tubular post extending upwardly from said base, supporting means secured to said post in predetermined spaced relation above said base and adjustable axially and angularly with respect to said post, said supporting means including a bracket extending to one side of said post and a housing extending to the opposite side of said post, a sewing machine carried by said bracket to said one side of, in spaced relation to, and substantially wholly rearwardly of said post, said sewing machine including a rotary main shaft, power transmitting means within and carried by said housing and including a motor disposed forwardly of said post and a rotary driving shaft substantially parallel to said main shaft, and means for imparting rotation to said main shaft in response to rotational movement of said driving shaft.

7. In a sewing machine unit, a base, a tubular post extending upwardly from said base, supporting means secured to said post in predetermined spaced relation above said base and including a bracket extending to one side of said post and a housing extending to the opposite side of said post, a sewing machine carried by said bracket to said one side of, in spaced relation to, and substantially wholly rearwardly of said post, said sewing machine including a reciprocable presser bar and spring pressed means for normally urging said presser bar in one direction, power transmitting means within and carried by said housing for driving said sewing machine, pump means for transmitting lubricant to predetermined regions of said sewing machine, and means for simultaneously moving said presser bar in the opposite direction against the action of said spring pressed means and for actuating said pump means.

8. In a sewing machine unit, a base, a tubular post extending upwardly from said base, supporting means secured to said post in predetermined spaced relation above said base and including a bracket extending to one side of said post and a housing extending to the opposite side of said post, a sewing machine carried by said bracket to said one side of, in spaced relation to, and substantially wholly rearwardly of said post, said sewing machine including a rotary main shaft, a work supporting platform secured to said base, said platform being spaced from said base, said post, and said sewing machine and being swingable about a substantially vertical axis, a second work supporting platform secured to said post intermediate said base and said supporting means, and power transmitting means within and carried by said housing and including a motor disposed forwardly of said post and a rotary driving shaft, and means responsive to rotational movement of said driving shaft for imparting rotation of said main shaft.

11

9. In a sewing machine unit, a base, a tubular post extending upwardly from said base, supporting means secured to said post above said base and including a bracket extending laterally from said post, a sewing machine carried by the free end of said bracket to one side of and in spaced relation to said post, said sewing machine including a reciprocable presser bar and spring pressed means for normally urging said presser bar in one direction, power transmitting means carried by said supporting means at the opposite side of said post for driving said sewing machine, treadles carried by said base, and connections from said treadles extending in part through said post for controlling said power transmitting means and operating said presser bar against the action of said spring pressed means.

10. In a sewing machine unit, a standard comprising a base and a tubular post extending upwardly from said base, supporting means secured to said post above said base and including a bracket extending laterally from said post, a sewing machine carried by said bracket at one edge thereof substantially wholly to one side of and in spaced relation to said post, said sewing machine including a rotary main shaft, a work carrying member secured to said standard, said member being spaced from said base, said post, and said sewing machine and being swingable about a substantially vertical axis, a second work carrying member secured to said post intermediate said base and said supporting means and swingable about the axis of said post, and power transmitting means disposed at the opposite side

12

of said post from said sewing machine, said power transmitting means including a shaft parallel to said main shaft, and means responsive to rotational movement of said driving shaft for imparting rotation to said main shaft.

11. In a sewing machine unit, a base, a rectangular standard extending upwardly from said base, a laterally extending supporting bracket carried by said standard at a point spaced above said base, a sewing machine mounted on said bracket in spaced relation to said base and said standard, power transmitting means mounted on said bracket and connected with said sewing machine for driving the same, treadles carried by said base, and connections from said treadles to said sewing machine and said power transmitting means for controlling the same, said bracket and base being shiftable angularly in relation to each other about the axis of said standard to adjust the position of said treadles in relation to said sewing machine.

GEORGE SAUER.

## REFERENCES CITED

The following references are of record in the file of this patent:

## UNITED STATES PATENTS

| Number    | Name        | Date          |
|-----------|-------------|---------------|
| 1,152,487 | Chenoweth   | Sept. 7, 1915 |
| 1,981,062 | Morrill     | Nov. 20, 1934 |
| 2,059,013 | Morrill     | Oct. 27, 1936 |
| 2,347,782 | Knott       | May 2, 1944   |
| 2,374,731 | Christensen | May 1, 1945   |