

(No Model.)

4 Sheets—Sheet 1.

W. W. HIBBARD.  
ELECTRIC SIGNALING APPARATUS.

No. 523,120.

Patented July 17, 1894.

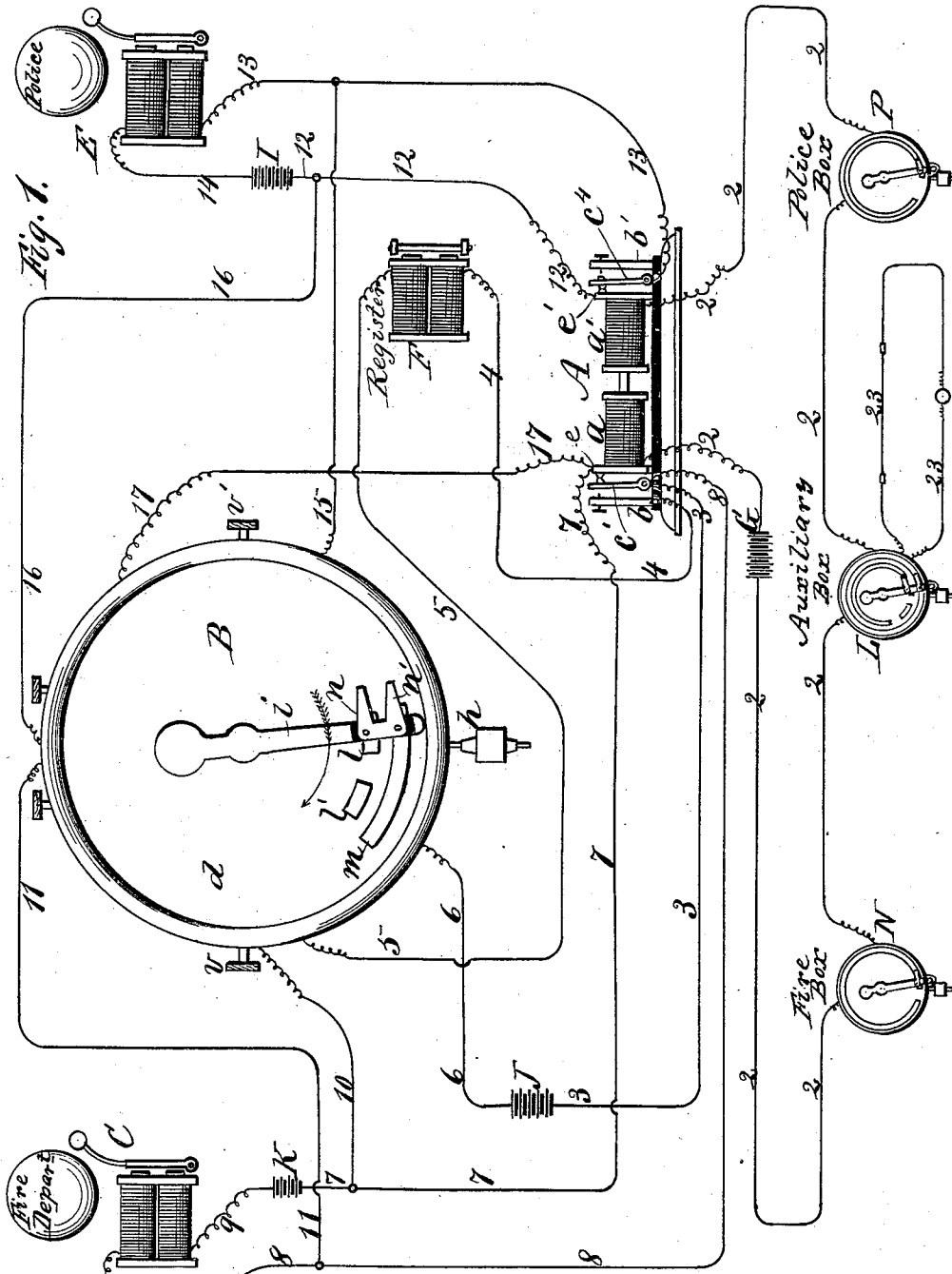

Witnesses.  
C. G. Braumell.  
Geo. B. Selden.

Inventor.  
Wm. W. Hibbard,  
per R. F. Osgood, Atty.

W. W. HIBBARD.  
ELECTRIC SIGNALING APPARATUS.

No. 523,120.

Patented July 17, 1894.

Fig. 3.

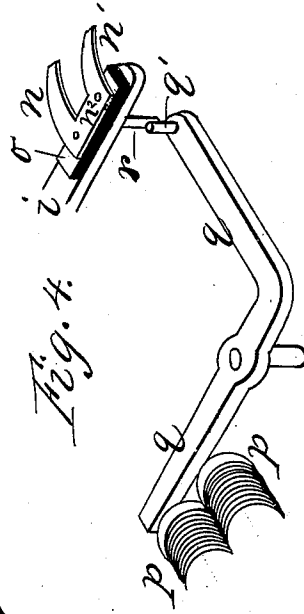
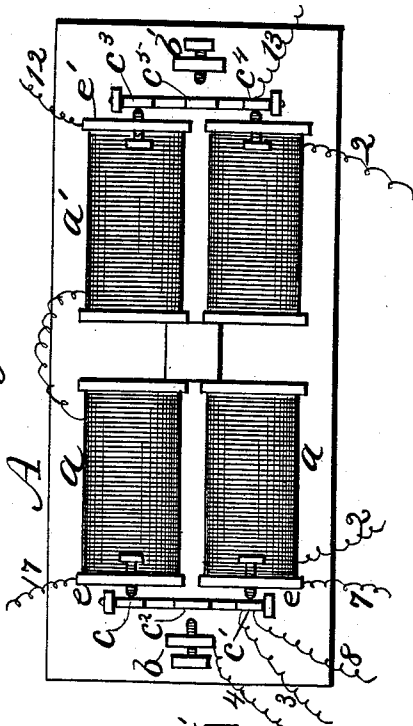
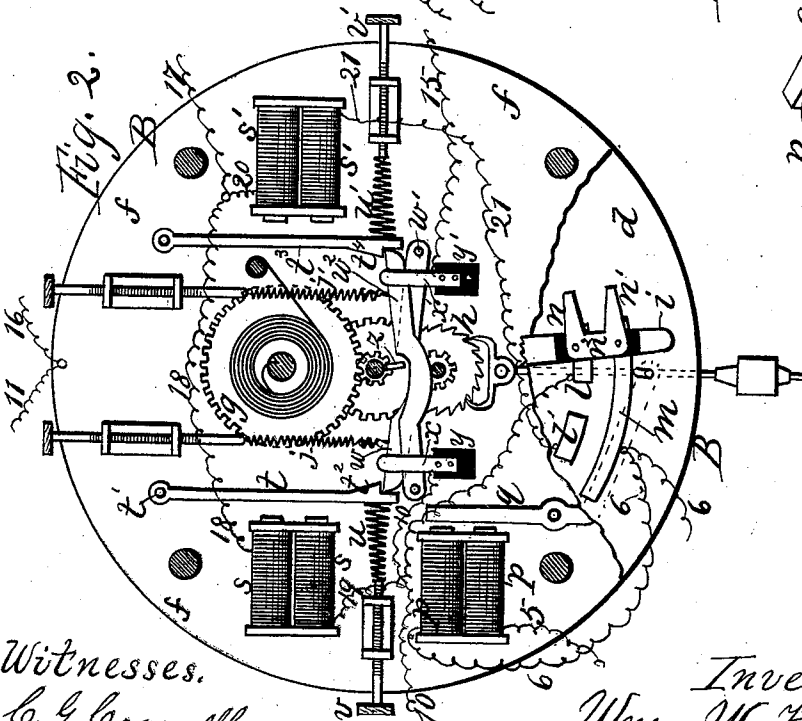

Fig. 4.

Fig. 2.



Witnesses.  
C. G. Cramell  
Geo. B. Selden.

Inventor  
Wm. W. Hubbard,  
per R. F. Osgood,  
Atty.

W. W. HIBBARD.  
ELECTRIC SIGNALING APPARATUS.

No. 523,120.

Patented July 17, 1894

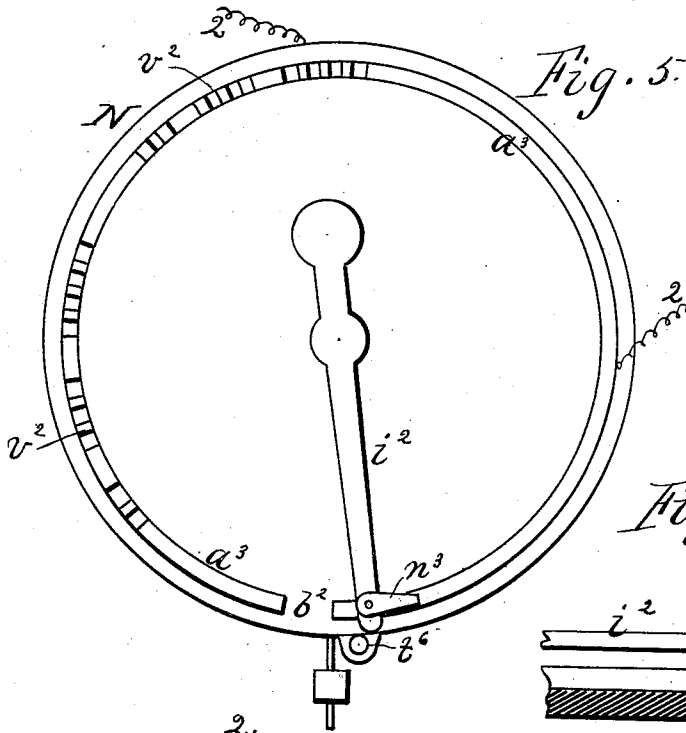

Fig. 5.

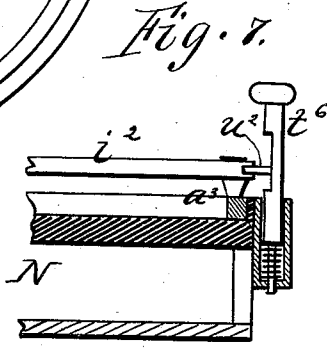

Fig. 7.

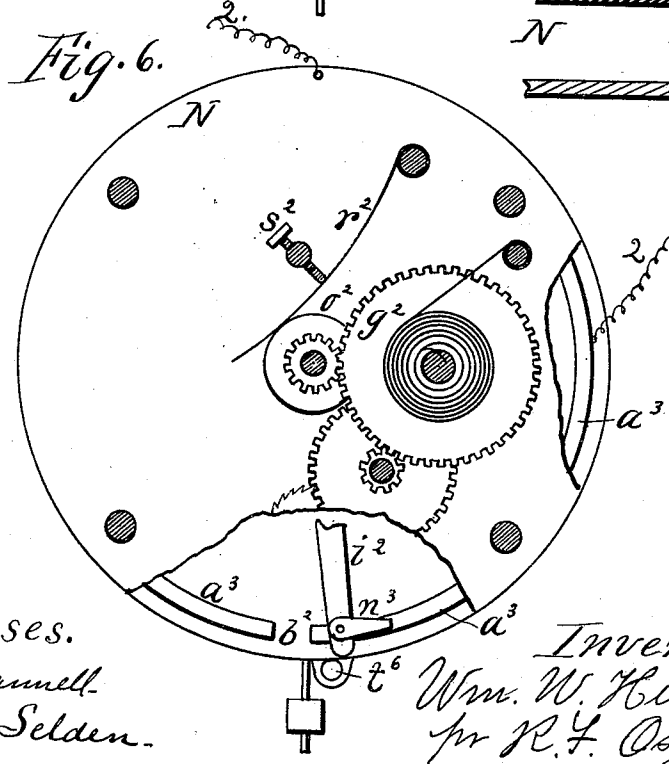

Fig. 6.

Witnesses.  
 C. L. Cramell.  
 Geo. B. Selden.

Inventor:  
 Wm. W. Hubbard,  
 per R. F. Osgood,  
 Atty.

W. W. HIBBARD.  
ELECTRIC SIGNALING APPARATUS.

No. 523,120.

Patented July 17, 1894.

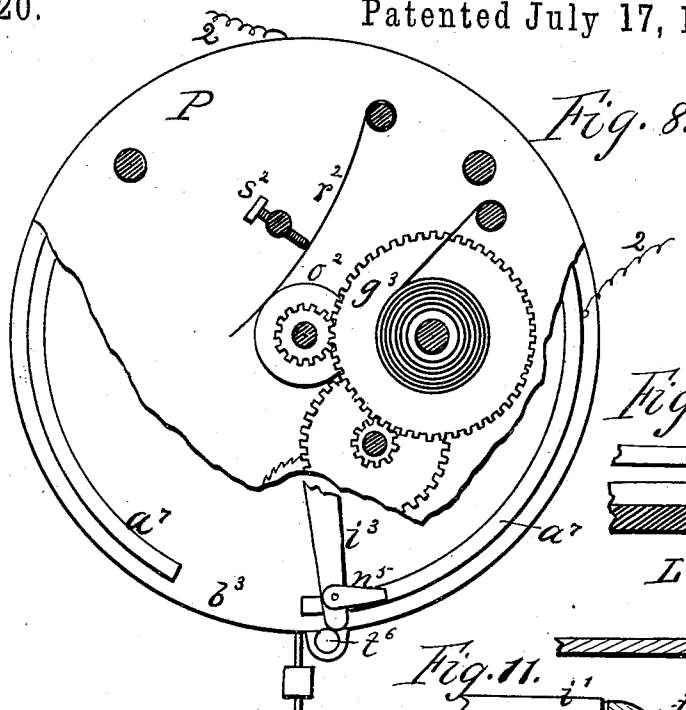

Fig. 8.

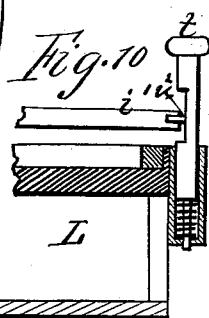

Fig. 10.

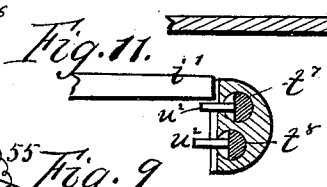

Fig. 11.

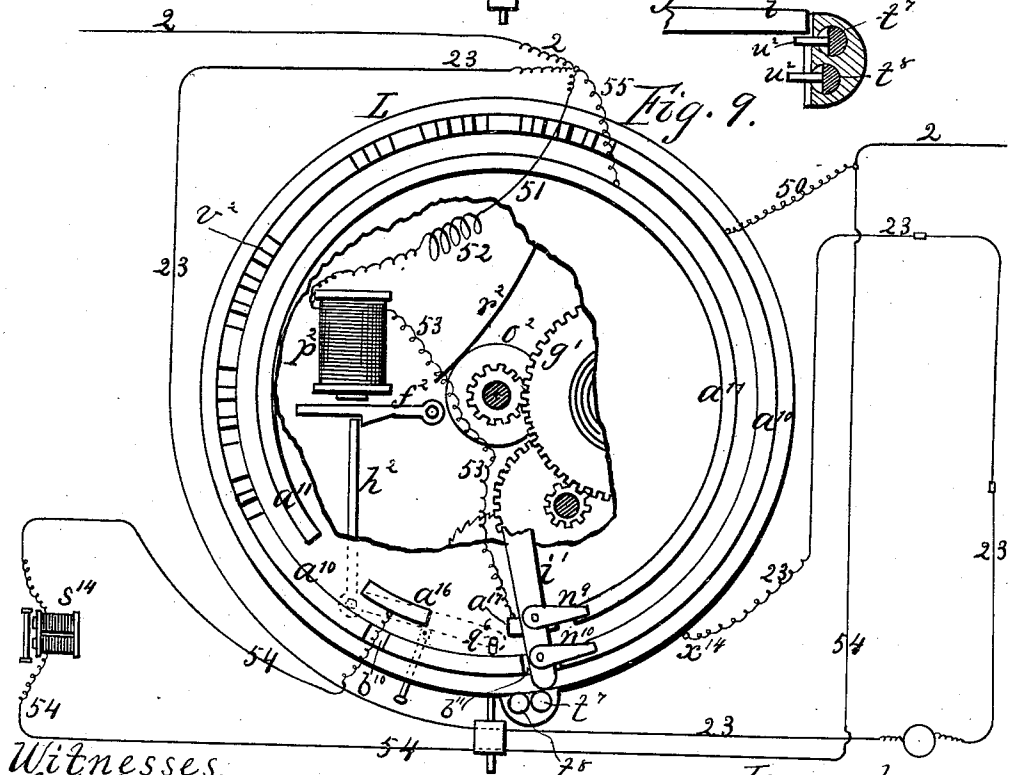

Fig. 9.

Witnesses.  
 C. F. Cramell  
 Geo. B. Selden.

Inventor.  
 Wm W. Hibbard,  
 per R. T. Osgood, Atty.

# UNITED STATES PATENT OFFICE.

WILLIAM W. HIBBARD, OF ROCHESTER, NEW YORK, ASSIGNOR TO THE  
STANDARD ELECTRIC SIGNAL COMPANY, OF SAME PLACE.

## ELECTRIC SIGNALING APPARATUS.

SPECIFICATION forming part of Letters Patent No. 523,120, dated July 17, 1894.

Application filed August 12, 1893. Serial No. 483,022. (No model.)

To all whom it may concern:

Be it known that I, WILLIAM W. HIBBARD, of Rochester, in the county of Monroe and State of New York, have invented a certain new and useful Improvement in Electric Signaling Apparatus; and I do hereby declare that the following is a full, clear, and exact description of the same, reference being had to the drawings accompanying this application.

This improvement relates to electric signals, more particularly fire alarm signals, and consists of a system embodying a main line provided with suitable signal boxes, said main line being normally closed, a relay with sub-circuits connecting therewith, a differentiating instrument by which the currents through the several sub-circuits are changed, and certain other connecting mechanism which will be more fully described.

In the drawings,—Figure 1 is a diagram showing a plan of the system. Fig. 2 is a face view of the differentiating instrument with the top removed to show the working parts. Fig. 3 is a plan view of the relay. Fig. 4 is a perspective view of the electrical stop apparatus of the differentiating instrument. Fig. 5 is a face view of one of the fire alarm boxes. Fig. 6 is a similar view with a portion of the top broken away to show the interior mechanism. Fig. 7 is a vertical section through the edge of Figs. 5 and 6, showing the finger knob for starting the signal apparatus of the fire alarm box. Fig. 8 is a face view of one of the police boxes with the top partially broken away. Fig. 9 is a face view of one of the auxiliary or sub-station boxes with the top partially broken away. Fig. 10 is a section through one edge of the auxiliary boxes showing the finger knobs for starting the apparatus. Fig. 11 is a horizontal cross section of Fig. 10.

In this system a central station or office is employed, where are located all the working parts including the batteries, the main line and sub-lines extending therefrom as will be more fully described.

In the drawings A indicates the relay, B the differentiating instrument, C an engine-house or fire department station, E a police or other station with which the system is connected, and F a magnet for operating a regis-

ter at the central station, whereon is recorded the number of the box where the alarm is given.

The relay A is made double where connection is made by the sub-circuits to two different points, say the fire department and the police station, and is so shown in the drawings, the same consisting of two pairs of electro magnets  $a a$  and  $a' a'$ , two sets of uprights  $e e$  and  $e' e'$ , two sets of swinging armatures, one set at each end of the relay, and two upright contact posts  $b$  and  $b'$ . The armature at one end of the relay consists of three arms  $c c' c^2$  attached to a common pivoted bar, the two outside ones  $c c'$  coming in contact with the uprights  $e e$  when the magnets are energized, and the middle one  $c^2$  in contact with the upright post  $b$  in the opposite position. The armature at the opposite end of the relay is of the same construction, consisting of the three upright arms  $c^3 c^4$  and  $c^5$ , and operate in the same manner.

The object of the differentiating apparatus B is to change the current from one circuit to another by the rotation of an arm which comes successively in contact with different conducting points on an insulated surface of the box. It consists of a circular case provided with an exterior face  $d$  of rubber or other insulating material, and a metallic base plate  $f$  which acts as a conductor.

$g$  is a time movement or clock-work of any suitable construction located in the case, and  $h$  an escapement connected therewith.

$i$  is an arm forming a circuit breaker attached to the time-movement the shaft of said arm extending from the base out through the insulated face of the instrument, and the arm resting across the same but not in contact therewith. The time movement when released gives motion to the arm and causes it to traverse over the face of the instrument.

$l l'$  and  $m$  are contact blocks forming electrodes set into the insulated face of the instrument, and  $n n'$  are two spring tongues forming contact points attached to the rotating arm  $i$ , and connected with each other by a conducting web  $n^2$ , said tongues and their connection being insulated from the arm by a rubber block  $o$ . As the arm rotates the spring tongues come in successive contact

with the several electrodes  $l$ ,  $l'$  and  $m$  and change the currents, as will be more fully described.

$pp$  is an electro-magnet within the instrument, and  $q$  is a pivoted crank forming an armature operating in connection therewith. On the outer end of this crank is a pin  $q'$  which passes out through a slot in the face of the instrument and intercepts a corresponding pin  $r$  on the under side of the arm  $i$ , thereby holding said arm against rotation. When magnet  $pp$  is charged the armature is drawn back removing pin  $q'$  from the path of pin  $r$  and allowing the swinging arm to rotate by means of the time-movement before described.

$s$  is another electro-magnet in the instrument, and  $t$  an armature pivoted at  $t'$  and provided with an inclined lug  $t^2$ . The armature  $t$  is pressed forward by a spring  $u$  tightened by a screw  $v$ . When the magnet is charged it overcomes the force of the spring and draws the armature back.

$w$  is an arm pivoted at  $w'$  connected with the base, its free end engaging with the inclined lug  $t^2$  of the armature  $t$ . When in this position the arm  $w$  rests in contact with a spring  $x$  attached to an insulated block  $y$ . When the armature is drawn back by the magnet the arm  $w$  frees from contact with the spring and opens the circuit passing there-through, and remains open till arm  $w$  is struck by a pin  $z$  on the shaft of the swinging arm  $i$ , which restores it to place by pressing it under the lug  $t^2$ . The arm  $w$  is drawn from contact with spring  $x$  by means of a coiled spring  $j$ . The above described arrangement is for communication with the fire department, as will presently be explained.

The same arrangement is duplicated on the opposite side of the differentiating instrument B, consisting of the magnets  $s'$ ,  $s'$ , the armature  $t^3$  provided with inclined lug  $t^4$ , spring  $w'$ , screw  $v'$ , arm  $w^3$ , contact spring  $x'$  attached to insulated block  $y'$ , and coiled spring  $j'$ , the whole operating to establish communication with the police department, or other station than the fire department, as will be more fully described.

The main circuit consists of a wire 2 laid through the streets or other locality where the line is to be established, said wire being provided with a battery G, at the central station. The terminals of wire connect with the two sets of magnets  $aa'$  of the relay, as shown in the diagram Fig. 1. All signal boxes and lateral circuits entering buildings are connected with this wire. Under normal conditions the circuit through the main line is closed, the magnets of the relay are charged, and the armatures of the relay are drawn back as shown in Figs. 1 and 3. But any opening of the main circuit releases the armatures and allows them to be drawn in the opposite direction against the posts  $bb'$ , and allows the circuit connected with the central station to come into operation at the proper time. The circuits are as follows: A circuit

extends from battery J through wire 3 to armature  $c'$ , thence, (when the main circuit has been broken and said armature is in contact with the upright post  $b$ ,) through post  $b$ , thence through wire 4, through the register magnet F, charging same and causing it to operate the registering apparatus, thence through wire 5 to and through magnet  $pp$  charging same, and thence through wire 6, (touching the conducting block  $m$ ,) back to battery J, thus completing the circuit. The energizing of magnets  $pp$  draws back armature  $q$ , removes pin  $q'$  from the path of pin  $r$ , and thereby releases the swinging arm  $i$  and allows it to revolve by means of the time-mechanism before described. It should be noted that the circuit J just described is normally open, and is closed only by the opening of the main circuit, and when the main circuit is again closed, as is done by operating a signal box, the circuit J is again opened and rendered non-operative by reason of the charging of the relay magnets  $aa$ . Another circuit extends from battery K at the central station to the fire department. This circuit is from battery K through wire 7, upright  $e$ , armature  $c'$ , wire 8, the magnet at the fire station, and wire 9 back to battery K. Auxiliary to circuit K is another circuit thus:— From battery K through wire 7, wire 10, spring  $x$ , arm  $w$ , the pivot  $w'$  of said arm  $w$  to the metallic base of the differentiating instrument, through said base, through wire 11, wire 8, the magnet at the fire department, wire 9, and back to battery K.

I is a circuit extending from the central station to the police or other station independent of the fire department. From battery I the circuit is through wire 12, upright  $e'$ , armature  $c^3$ , wire 13, the magnet at the police station, wire 14, back to battery I. Auxiliary to this circuit is a circuit from battery I through wire 14, the magnet at the police station, wire 13, wire 15, spring  $x'$ , arm  $w^3$ , the pivot  $w^3$  of said arm, through the metallic base of the differentiating instrument, wire 16, and wire 12, back to battery I.

The circuit K and its auxiliary circuit just described are duplicates of the circuit I and its auxiliary before described, one circuit and its auxiliary connecting with the police department and the other circuit and its auxiliary with the fire department.

In the main line are located the various boxes for giving signals; and from said main line also extend loops into buildings and other localities to be guarded, said loops forming sub-circuits and provided with thermostats and manual boxes as required.

The first action in opening and then closing the main circuit is to temporarily close the local circuit J and thus start the differentiating instrument as before described, also operating the register F at the central station and later recording the number of the box from which the signal is sent, said recording being done by punching holes in a slip of pa-

per or by other means. The movement of the arm  $i$  now causes the springs  $n n'$  to come in contact with the blocks  $l m$ , thereby forming a new circuit. This circuit is from battery J through wire 3, armature  $c'$  (then in contact with the upright of the relay magnet), wire 17, wire 18, magnets  $s s$ , wire 19 to contact block  $l$ , thence through the tongues  $n n'$  to contact block  $m$ , through wire 6, back to battery J. The result of thus charging magnets  $s s$  is to draw armature  $t$  back and release the spring arm  $w$ , allowing the latter to separate from spring  $x$ , thus breaking the shunt circuit that previously existed by contact of the arm with the spring and extending through the base of the instrument wire 11. The further progress of swinging arm  $i$  causes spring  $n$  to leave block  $l$ , breaking the circuit just described, and brings the springs  $n n'$  in contact with blocks  $l' m$  and closes a new circuit from battery as follows:—From battery J through wire 3, armature  $c'$ , upright  $e$ , wire 17, wire 20, magnets  $s' s'$ , (energizing the same,) wire 21, contact block  $l'$ , springs  $n n'$ , contact block  $m$ , wire 6, back to battery J. The energizing of magnets  $s' s'$  draws armature  $t^3$ , releases the pivoted arm  $w^3$ , from spring  $x'$  in the same manner as on the opposite side of the differentiating instrument, thereby breaking the shunt circuit that previously existed leading from battery I through the base of the instrument to wire 16. This shunt circuit, together with its companion on the opposite side leading out from the base of the instrument through wires 11 and 16, will not be re-established again till arms  $w$  and  $w^3$  are forced into engagement with the armatures  $t$  and  $t^3$  by the pin  $z$  near the end of the rotation of swinging arm  $i$ , said pin striking shoulders of the arms, shown at the right of the pin in Fig. 2, then escaping past said shoulders into cut-away portions of the arms, thus allowing motion when the pin starts again. The condition at this junction is this: Both of the shunt circuits, one leading to the fire department, the other to the police station, are open during the remainder of the rotation of the swinging arm  $i$  after leaving the contact blocks  $l' m$ , and until the pin  $r$  of the swinging arm strikes the pin  $q'$  of armature  $g$ , bringing the arm to a stop again. Under such conditions the circuit through the fire department is from battery K through wire 7, upright  $e$ , armature  $c c'$ , (then drawn back by the magnets  $a a$  and subject to any action of the relay,) wire 8, through the magnet at the fire station, and thence through wire 9 back to battery K. At the same time the circuit through the police station is from battery I through wire 12, upright  $e'$  armatures  $c^3 c^4$ , wire 13, through the magnet at the police station, and wire 14 back to battery I. It will be seen that at this juncture the register F, the fire station C, and the police station E, are each, through the armature at the relay, rendered susceptible to the operation of the relay. Any signal transmitted over the main

line will thus, by closing the circuits at the relay, be transmitted to the central-station register, the fire station and the police station. 70

The street boxes N and P have, respectively, time movements  $g^2 g^3$ , also contact rim  $a^3$  and  $a^7$  set into their insulated faces, said rims having respectively breaks  $b^2$  and  $b^3$  just in advance of the starting points of the swinging arms, as shown in Figs. 5 and 8. The auxiliary or sub-station boxes L also have a time movement  $g'$  and contact rings and blocks  $a^{10} a^{11} a^{16}$  and  $a^{17}$ , as shown in the face view Fig. 9. Each of the swinging arms  $i^2 i^3$  of the street boxes has a single spring tongue  $n^3$  and  $n^5$  in electrical connection therewith, which rests in contact with the circular rim  $a^3$  or  $a^7$ . In like manner the swinging arm  $i'$  of the auxiliary boxes L has two separate spring tongues  $n^9 n^{10}$  in electrical connection therewith and resting in contact with the two outer rings  $a^{10} a^{11}$ . The auxiliary boxes L also have an electro-magnet  $p^2$ , pivoted armatures  $f^2$ , and pivoted crank arm  $h^2$ , similar to the corresponding devices in the differentiating instrument, said crank arm carrying a stop pin  $q^6$  at its outer end for restraining the swinging arm. The energizing of said magnet removes the stop pin and releases the swinging arm in a similar manner to that in the differentiating instrument. Each of the boxes L N P is also provided with a wheel  $o^2$  on the shaft of the swinging arm, against the periphery of which wheel bears a spring  $r^2$ , pressed up by a screw  $s^2$  the object of which is to apply sufficient friction to prevent back action of the clock gearing. The exterior conducting rings of all the boxes have circuit breaking notches or teeth  $v^2 v^2$  in two series, corresponding with the station number of the boxes, for sounding alarm over the main line. In addition to these devices the boxes N P, are started in operation manually by pressing the finger on a knob  $f^6$  which removes a restraining pin  $w^2$  from contact with the end of the swinging arm and allows the latter to rotate. When once started the swinging arm in the fire and police boxes continues its rotation till a full circuit is made, when it strikes the pin of the finger knob again and is stopped ready for another action. In the auxiliary boxes, however, the swinging arm, after being released as above described, is restrained by the stop pin on the crank arm  $h^2$  and is started again only by the electrical action before described. The auxiliary boxes are provided with two finger knobs  $f^7 f^8$  with holding pins  $w^2 w^2$  by which means the swinging arm has two separate stops before it reaches the electrical stop. The double finger stops are for the purpose of enabling testing to be done without sounding an alarm at the central station. After such testing has been done the swinging arm is released from the finger stops and moves forward to the electrical stop and is ready for electrical action to set it in motion. In this condition of the auxiliary box the circuit is from battery

G through wire 2 wire 23 to the base of the auxiliary box at  $x^{14}$ , swinging arm  $i'$  tongue  $n^{10}$ , contact ring  $a^{10}$  wire 50, wire 2 back to battery. If the circuit through wire 23 is broken the circuit is then as follows:—from battery G through wire 2, wire 51, resistance coil 52, electro magnet  $p^2$ , wire 53, contact block  $a^{17}$ , tongue  $n^9$ , tongue  $n^{10}$  ring  $a^{10}$  wire 50, and wire 2 back to battery. This energizes magnet  $p^2$ , releases the electrical stop pin and allows the swinging arm to rotate. A small degree of movement brings tongue  $n^{10}$  over the first notch  $b^{11}$  in the outer ring  $a^{10}$ , which notch, however, does not go through the ring. This breaks the current through the main line and puts the differentiating instrument in operation as before described. Further progress of the swinging arm  $i'$  brings tongue  $n^{10}$ , out of the notch and in contact again with ring  $a^{10}$ , thus restoring the circuit provided wire 23 is intact, which is the case where its current has been opened and again closed as by a thermostat or manual box. The circuit is then from battery G through wire 2 wire 23 base of the instrument, swinging arm  $i'$ , tongue  $n^{10}$ , ring  $a^{10}$ , wire 50, wire 2, back to battery. In case wire 23 is permanently broken the circuit is not restored until the tongues  $n^9$  and  $n^{10}$  have come in contact with the rings  $a^{10}$   $a^{11}$  after passing the breaks in ring  $a^{11}$ . The swinging arm in passing over contact block  $a^{16}$  produces a new circuit in case wire 23 is intact. In such case the circuit is from battery G through wire 23, base of the instrument at  $x^{14}$ , swinging arm  $i'$  tongue  $n^9$ , (tongue  $n^{10}$  being then in notch  $b^{10}$ ) contact block  $a^{16}$  wire 54, through a magnet  $s^{14}$  which rings a gong or sounds some other alarm in the building, thence through wire 2 back to battery. The further progress of the swinging arm brings the tongues in contact with the rings  $a^{10}$   $a^{11}$ , thus establishing the following circuit whether wire 23 is intact or permanently broken viz:—from battery G through wire 2, wire (55) ring  $a^{11}$  tongues  $n^9$   $n^{10}$ , ring  $a^{10}$  wire (50), and wire 2 back to battery.

By the use of the auxiliary boxes alarms are sounded automatically at the central station by the action of thermostats which open at a given temperature and then close again, or by the action of manual signals, also by the breaking of wires or other disarrangements. In case of fire the signal will also be sent to the fire department, and in case of a broken wire to the central station only.

The fire and police boxes are without magnets, being manipulated entirely by manual action by pressing the knobs and releasing the swinging arm as before described. The circuit is thus:—from battery G through wire 2 base of the instrument, swinging arm  $i^2$  or  $i^3$ , tongue  $n^8$  or  $n^5$ , ring  $a^8$  or  $a^7$ , and wire 2 back to battery.

The spring tongue in passing over the notches  $v^2$   $v^3$  sounds the number of the box at the central station. In the fire boxes the

alarm is also sent to the fire department and police department and in the case of the police boxes to the police department without being sent to the fire department. The only difference in the two boxes is that the break  $b^8$ , in the police boxes is of greater length than that in the fire boxes, and is of such length that the circuit in wire 2 having been broken, and the differentiating instrument at the central station having been started, the current in wire 2 will remain broken until such time as the swinging arm of the differentiating instrument shall have passed the point where the fire department circuit is placed in position to receive signals from wire 2. In such case the signals given at the police boxes are sent to the central station and from there to the police station without being sent into the fire department.

Having described my invention I do not claim in this application the double-wire system shown and described in my pending application, Serial No. 483,023, filed contemporaneously herewith. Neither do I claim the construction of the differentiating apparatus and the street and auxiliary boxes shown in my contemporaneous applications, Serial Nos. 483,024, 483,025 and 483,026.

What I claim as new, and desire to secure by Letters Patent, is—

1. In an electric signaling apparatus, the combination of a main circuit provided with signal boxes, a side circuit, a magnet for controlling the side circuit, a differentiating apparatus with which both circuits are electrically connected, a circuit-breaker driven by suitable mechanism and restrained by an electric stop, a magnet for releasing the stop, electrodes attached to the differentiating apparatus in line with the circuit breaker, and a magnet for operating a register, as specified.

2. In an electric signaling apparatus, the combination of a main circuit provided with signal boxes, a side circuit, a relay with which the main circuit is connected, a differentiating apparatus electrically connected with the relay and side circuit, a magnet for controlling the side circuit, a circuit-breaker driven by suitable mechanism and restrained by an electric stop, a magnet for releasing the stop, electrodes attached to the differentiating apparatus in line with the circuit-breaker, and a magnet for operating a register at the central station, as specified.

3. In an electric signaling apparatus, the combination of a main circuit provided with signal boxes, a side circuit, a magnet for controlling the side circuit, a differentiating apparatus with which both circuits are electrically connected, a circuit breaker, a time mechanism provided with an escapement for driving the circuit breaker, an electric stop for restraining the circuit breaker, a magnet for releasing the stop, electrodes attached to the differentiating apparatus in line with the circuit breaker, and a magnet for operating a register at the central station, as specified.

4. In an electric signaling apparatus, the combination of a main circuit provided with signal boxes, two side circuits, magnets for controlling the side circuits, a differentiating apparatus with which the main circuit and both side circuits are connected, a circuit breaker driven by suitable mechanism and restrained by an electric stop, a magnet for releasing the stop, electrodes attached to the differentiating apparatus in line with the circuit breaker, and a magnet for operating a register at the central station, as specified.

5. In an electric signaling apparatus, the combination of a normally-closed main circuit, a relay with which it connects, a differentiating apparatus electrically connected with the relay, a side circuit electrically connected with the differentiating apparatus, a magnet for controlling the side circuit, a circuit breaker, a mechanism for driving the circuit breaker, an electrical stop for restraining the circuit breaker, a local circuit and a magnet for controlling the stop, electrodes attached to the differentiating apparatus in line with the circuit breaker, and a magnet

for operating a register at the central station, as specified.

6. In an electric signaling apparatus, the combination of a main circuit, a differentiating apparatus with which the main circuit is electrically connected, a circuit breaker, mechanism for driving the same, an electric stop for restraining the circuit breaker, a magnet for controlling the stop, a circuit connected with the differentiating apparatus extending to a side station, a magnet for controlling said side circuit, an armature operating in connection with the magnet, a lever controlled by the magnet for opening and closing a local circuit, and a device operated by the driving mechanism for resetting the lever, as specified.

In witness whereof I have hereunto signed my name in the presence of two subscribing witnesses.

W. W. HIBBARD.

Witnesses:

R. F. OSGOOD,  
GEORGE A. BENTON.