

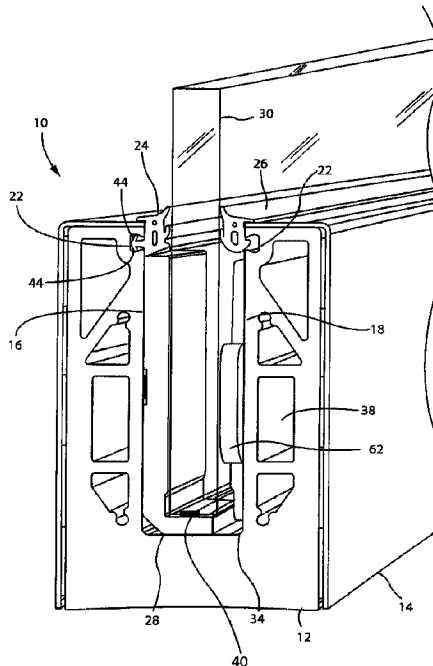

(22) **Date de dépôt/Filing Date:** 2017/10/20
(41) **Mise à la disp. pub./Open to Public Insp.:** 2018/04/21
(45) **Date de délivrance/Issue Date:** 2023/02/07
(62) **Demande originale/Original Application:** 3 051 554
(30) **Priorités/Priorities:** 2016/10/21 (US62/411,347);
2017/10/19 (US15/788,616)

(51) **Cl.Int./Int.Cl. E04F 11/18** (2006.01),
E06B 3/54 (2006.01)
(72) **Inventeur/Inventor:**
SPRAGUE, GARY, US
(73) **Propriétaire/Owner:**
C.R. LAURENCE CO., INC., US
(74) **Agent:** RICHES, MCKENZIE & HERBERT LLP

(54) **Titre : AMELIORATIONS AU SYSTEME A BLOCAGE CONIQUE**
(54) **Title: TAPER-LOC SYSTEM IMPROVEMENTS**



(57) **Abrégé/Abstract:**

An improved base shoe 12 for use with the panel installation and removal system described in U.S. Patents Nos. 8,122,654 and 8,201,366 is presented. The improved base shoe 12 featuring dovetail grooves 22 for use with a safety-seal weather seal 24, wherein the safety-seal weather seal 24 must be installed prior to installing a glass panel 30. The safety-seal weather seal 24 eliminates a safety risk incurred by installers who attempt to install a press in seal 26 at an outboard base shoe to glass panel interface of an installed panel 30 and base shoe 12. In an alternative embodiment, the improved base shoe 12 features a recess 66 for use with taper plates 62 having a continuous projection 64 along an upper surface. The base shoe 12 and taper plates 62 are configured so as to provide a prying surface between the projection 64 on the taper plates 62 and a wall 18 of the base shoe 12.

ABSTRACT OF THE DISCLOSURE

An improved base shoe 12 for use with the panel installation and removal system described in U.S. Patents Nos. 8,122,654 and 8,201,366 is presented. The improved base shoe 12 featuring dovetail grooves 22 for use with a safety-seal weather seal 24, wherein the safety-seal weather seal 24 must be installed prior to installing a glass panel 30. The safety-seal weather seal 24 eliminates a safety risk incurred by installers who attempt to install a press in seal 26 at an outboard base shoe to glass panel interface of an installed panel 30 and base shoe 12. In an alternative embodiment, the improved base shoe 12 features a recess 66 for use with taper plates 62 having a continuous projection 64 along an upper surface. The base shoe 12 and taper plates 62 are configured so as to provide a prying surface between the projection 64 on the taper plates 62 and a wall 18 of the base shoe 12.

**TAPER-LOC SYSTEM IMPROVEMENTS
RELATED APPLICATIONS**

[0001] This application is filed as a divisional application resulting from Canadian Patent Application Serial No. 3,051,554, filed 20 October 2017, and which has been filed as a division of Canadian Patent Application Serial No. 2,998,171, filed 20 October 2017, and which has been submitted as the Canadian national phase application of International Patent Application No. PCT/US2017/057706, filed 20 October 2017.

TECHNICAL FIELD

The present invention relates generally to panel installation and removal systems and more particularly to improvements to the panel installation and removal system described in U.S. Patents Nos. 8,122,654 ("the '654 patent") and 8,201,366 ("the '366 patent"), the commercial embodiments of which are referred to as the "Taper-Lod" system.

BACKGROUND

[0002] Glass panel railing systems are used in commercial spaces and homes, and frequently are desired due to an attractive appearance derived from transparent or translucent properties. They typically are used as guard rails for walk ways in the proximity of commercial facilities and as barriers at the edges of physical drop offs for the protection of pedestrians, as well as for partitioning interior spaces in commercial buildings. Known glass panel systems include vertical panels and a base shoe assembly. The bottom edges of the panels are installed in the base shoe assembly while the top edges may support a top rail or handrail. Installation of the bottom edges of the glass panels into a base shoe assembly however can be difficult, expensive and time-consuming.

[0003] Prior to the development of the Taper-Loc system as described in the '654 and '366 patents, glass panel installation systems and methodology suffered

from a number of disadvantages. Some systems required cement to hold the panels in place in a base shoe. Due to the quick setting nature of the cement, often installers lacked sufficient time to place the panels in a base shoe, align the panels and ensure that the cement maintained a smooth and attractive appearance. Another drawback of this system was that adjustments to a panel's final position were essentially impossible after the cement had set.

[0004] Other commonly employed systems involved driving a wedge vertically into a base shoe, typically using a hammer and punch, and thereby wedging the glass panel into the base shoe. Systems of this type however, lacked a precise way to control the degree of clamping force used to secure a panel in the base shoe. Moreover, the base shoe's decorative cladding was prone to damage during insertion of the wedge and particularly during any attempted removal of the wedge for adjustment of the glass panel or replacement. In addition, an errant blow of the hammer could damage either the glass panel, base shoe or both.

[0005] With the development of the Taper-Loc system as described in the '654 and '366 patents, the problems associated with the prior art systems for installing glass panels in a base shoe were largely eliminated. Essentially, the Taper-Loc system comprises a base shoe or rail, spacers, a glass panel and taper plates. The components as depicted in the patents may be described as follows. The base shoe comprises a rail for holding a glass panel. The base shoe is in the

form of an aluminum c-channel style extrusion with relatively thick side walls. Set within the channel of the base shoe against one wall and the floor of the channel are spacers. The spacers are typically set within the shoe at intervals along the length of the base shoe. The spacers are made of plastic and serve to prevent the glass panel from directly contacting the aluminum wall or bottom surface of the base shoe. The spacers may be attached to the base shoe by means of double-sided adhesive tape.

[0006] The taper plates are tapered plates that are designed to engage at their thinnest ends and slide against each other such that the combined thickness of the plates increases as the plates engage along their length. The maximum combined thickness of the plates is achieved when the plates are fully overlapping. The plates include projection tabs that allow them to be used with a special tool which both drives the plates together upon installation of a glass panel in a base shoe and also functions to separate the plates in the event a shoe or panel requires replacement. The taper plates will typically be fabricated from steel or aluminum, but other metallic materials and some plastic materials are also suitable.

[0007] In a typical assembly, the spacers are glued at intervals to the base shoe, a glass panel is inserted in the shoe and rests upon and against the spacers. A pair of taper plates, where one pair of taper plates corresponds to each spacer, are located on the opposite side of the glass panel, and are positioned in the shoe with

the thin edges of the plates partially overlapping. A side of one of the taper plates contacts the wall of the glass panel, whereas a side of the other taper plate contacts the wall of the shoe. The shoe-side taper plate is stationary. When the taper plates are driven together, the glass-side plate slides along the length of the stationary shoe-side plate.

[0008] As the taper plates are driven to their fully overlapped configuration, compressive force builds up between the taper plates, glass panel, spacer and the walls of the base shoe so as to secure the base shoe to the glass panel. Thereafter, press-in seals are typically installed on both sides of the base shoe to glass plate interface.

[0009] Though the above-described Taper-Loc system has dramatically improved upon the systems of the prior art, certain drawbacks of the system have been uncovered during use. In particular, installers will often install a base shoe, glass panel and rail assembly while saving the task of installing weather seals on the base shoe to seal the shoe to glass panel interface or seam as the last part of the installation job. This often results in installers leaning out over an installed rail assembly, without wearing a safety harness, to press in the outboard weather seal, thus creating a potentially unsafe condition where an installer could potentially fall over a rail and sustain injury.

[0010] Another issue that has been observed on job sites is that installers have

discovered that when it is desired to remove a base shoe from a glass panel, the insertion force of the taper plates upon initial installation causes the base shoe-side taper plate to stick to the base shoe and become quite difficult to remove from the base shoe. The use of silicone sealant at the taper plate interface, as some installers are want to do, compounds this problem. The problem may significantly increase the time required by installers to replace base shoes or glass panels on a job site.

[0011] What is needed therefore is a revised base shoe that requires at least one weather seal to be installed prior to the installation of a glass panel in the shoe and thereby eliminate problem where some installers incur safety risks by leaning out over an installed rail assembly for the purpose of installing a press-in outboard whether seal. It would also be desirable to provide a revised taper plate and base shoe design that includes provisions for removing a previously installed taper plate which is adhered or stuck to a wall of the base shoe.

DISCLOSURE OF THE INVENTION

[0012] The improved base shoe or rail of the present invention features a dovetail groove formed into an interior face of an outboard vertical side wall of the base shoe. The dovetail groove allows for the use of a weather seal configured with two projections which engage the interior side walls of the dovetail groove. Due to the nature of this design, the outboard weather seal must be inserted into the dovetail groove prior to the insertion of the glass pane into the base shoe, i.e. the

weather seal cannot be inserted, or at least is quite difficult to insert, in the base shoe after installation of the glass panel. This design is advantageous from a safety viewpoint because it requires the outboard weather seal to be installed prior to installation of the glass panel and therefore eliminates safety risk, i.e. the risk of falling, that occurs when installers reach over an installed railing to install press-in seals at the outboard glass panel to base shoe interface.

[0013] Another improvement to the base shoe and taper plate assembly of the present invention regards replacing the plurality of spacers used at intervals on the base shoe with a continuous setting strip which would serve the function of the spacers, i.e. preventing contact between the glass panel and the interior face of the outboard wall of the base shoe. Universal setting block tape strips have also been added to attach the setting block to the base shoe and the glass panel to the setting block. The continuous setting strip and tape strips provide increased efficiency in installation by eliminating the need to glue in place numerous individual spacers.

[0014] The improved base shoe and taper plates of the present invention further improve upon the prior art by presenting a taper plate design that features a continuous projection or tab along a top surface of the taper plate where the projection rests upon a recess formed into an interior face of an inboard vertical side wall of the base shoe. The taper plate, equipped with the projection, and the depth of the recess in the base shoe, are configured such that there is a small gap between

the edge of the projection and the interior face of the inboard side wall of the base shoe. The projection in combination with the gap between it and the interior face of the inboard vertical side wall provides a prying surface that allows an installer to insert a chisel, pry bar or even a screwdriver into the gap and pry the against the projection to separate the taper plate from the inboard side wall of the base shoe.

[0014a] Accordingly, in one aspect, the present invention resides in a shoe assembly, comprising: a. a base shoe, comprising: i. a first inner side wall having a top side and a bottom side, ii. a second inner side wall having a top side and a bottom side, iii. a bottom wall adjacent to the bottom side of the first inner side wall and the bottom side of the second inner side wall, the first inner side wall, the second inner side wall, and the bottom wall defining a base shoe channel, iv. a first dovetail groove formed in the first inner side wall adjacent to the top side of the first inner side wall, and v. a second dovetail groove formed in the second inner side wall adjacent to the top side of the second inner side wall; b. a continuous setting strip comprising a top arm and a bottom arm projecting perpendicularly from the top arm, and a centrally located channel for the receipt of a continuous tape strip wherein the continuous tape strip secures the continuous setting strip to the base shoe; the continuous setting strip positioned inside the base shoe channel against the first inner side wall.

[0014b] In another aspect, the present invention resides in a shoe assembly, comprising: a) a base shoe, the base shoe comprising: i. a first inner side wall having a top side and a bottom side, ii. a second inner side wall having a top side and a bottom side, iii. a bottom wall adjacent to the bottom side of the first inner side wall and the bottom side of the second inner side wall, the first inner side wall, the second inner side wall, and the bottom wall defining a base shoe channel, iv. a first dovetail groove formed in the first inner side wall adjacent to the top side of the first inner side wall, and v. a second dovetail groove formed in the second inner side wall adjacent to the top side of the second inner side wall; and b) a press-in weather seal, the press-in weather

seal comprising: i. a body section having a top side, a bottom side opposite the top side, a lateral side adjacent to the top side and the bottom side, and a medial side opposite the lateral side and adjacent to the top side and the bottom side, and ii. a dovetail groove engagement portion extending from the body section on the lateral side for engaging the second dovetail groove, and iii. a plurality of channels extending a length of the body section; c) a continuous setting strip comprising a top arm and a bottom arm projecting perpendicularly from the top arm and a centrally located channel for the receipt of a first continuous tape strip wherein the first continuous tape strip secures the continuous setting strip to the base shoe; and d) a second continuous tape strip mounted on the bottom arm of the continuous setting strip.

[0014c] In a further aspect, the present invention resides in a shoe assembly, comprising: a. a base shoe, the base shoe comprising: i. a first inner side wall having a top side and a bottom side, ii. a second inner side wall having a top side and a bottom side, iii. a bottom wall adjacent to the bottom side of the first inner side wall and the bottom side of the second inner side wall, the first inner side wall, the second inner side wall, and the bottom wall defining a base shoe channel, iv. a first dovetail groove formed in the first inner side wall adjacent to the top side of the first inner side wall, and v. a second dovetail groove formed in the second inner side wall adjacent to the top side of the second inner side wall; b. a continuous setting strip comprising a top arm and a bottom arm projecting perpendicularly from the top arm and a centrally located channel for the receipt of a first continuous tape strip wherein the first continuous tape strip secures the continuous setting strip to the base shoe; c. a second continuous tape strip mounted on the bottom arm of the continuous setting strip; d. a safety weather seal, comprising: i. a body section having a top side, a bottom side opposite the top side, a lateral side adjacent to the top side and the bottom side, and a medial side opposite the lateral side and adjacent to the top side and the bottom side, and one or more safety weather seal channels extending a length of the body section, wherein the bottom side is tapered; ii. a

dovetail groove engagement portion extending from the lateral side of the body section, the dovetail groove engagement portion terminating at a pair of opposing projections for engaging the first dovetail groove; iii. a lateral lip protruding from the top side of the body section on the lateral side adjacent to the dovetail groove engagement portion; iv. at least one glass scraper seal protruding from the medial side; and e. a press-in weather seal, the press-in weather seal comprising: i. a body section having a top side, a bottom side opposite the top side, a lateral side adjacent to the top side and the bottom side, and a medial side opposite the lateral side and adjacent to the top side and the bottom side, wherein the bottom side is tapered; ii. a dovetail groove engagement portion extending from the body section on the lateral side; iii. a lateral lip for covering a gap between the body section and the second inner side wall of the base shoe when the dovetail groove engagement portion is engaged with the second dovetail groove; iv. a medial lip projecting away from the body section on the medial side at the top side of the body section of the press-in weather seal; v. at least one scraper seal extending from the medial side; vi. at least one press-in weather seal channel extending a length of the body section.

[0015] The above and other features of the invention will become more apparent from the following detailed description.

BRIEF DESCRIPTION OF THE DRAWINGS

[0016] Fig. 1 is an elevation view of a base shoe of the present invention which incorporates dovetail grooves for weather seals with some parts removed for clarity.

[0017] Fig. 2 is another sectional view of a base shoe of the present invention

weather seal.

[0022] Fig. 7 is a close up perspective view of an embodiment of the press-in weather seal of the present invention.

[0023] Fig. 8 is a close up perspective view of another embodiment of the press-in weather seal of the present invention.

[0024] Fig. 9 is an elevation view of a base shoe viewed from one end with the taper plate installed.

[0025] Fig. 10 is an elevation view of a base shoe viewed from one end without the glass panel.

MODES FOR CARRYING OUT THE INVENTION

[0026] The present invention will now be described more fully hereinafter with reference to the accompanying drawings, in which preferred embodiments of the invention are shown. The invention may, however, may be embodied in many different forms and should not be construed as being limited to the embodiments set forth herein. Rather these embodiments are provided so that this disclosure will be thorough and complete, and will fully convey the scope of the invention to those skilled in the art. Like numbers refer to like elements throughout.

[0027] With reference to Figure 4, an embodiment of the improved base shoe assembly 10 of the present invention is shown. The base shoe assembly 10 features a base shoe 12 in the form of a channel section, which may be surrounded by

decorative cladding 14. Inserted in the base shoe 12 is a safety weather seal 24 and a press-in weather seal 26, a continuous glass setting strip 28, a glass panel 30 and a pair of taper plates 62 which secure the panel 30 in the base shoe 12.

[0028] With reference to Figs. 1 and 2, the base shoe 12 features a first inner side wall 16 having a top side 15 and a bottom side 17 opposite the top side 15, a second inner side wall 18 also having a top side 19 and a bottom side 21 opposite the top side 19, and a bottom wall 34 adjacent to the bottom side 17 of the first inner side wall 16 and the bottom side 21 of the second inner side wall 18, the first inner side wall 16, the second inner side wall 18, and the bottom wall 34 defining a base shoe channel 36 therebetween. The top side 15 of the first inner side wall 16 and the top side 19 of the second inner side wall 18 define an opening 23. The base shoe 12 may, optionally, be formed with a plurality of lightening passages 38 which may be of a variety of cross-sectional shapes and serve to reduce the weight of the base shoe 12. The base shoe 12 may also include a dovetail groove 22 formed into each of the first and second inner side walls 16, 18, near the opening 23 of the channel 36. The dovetail grooves 22 are configured to accept either the safety weather seal 24 or the press-in weather seal 26.

[0029] A continuous setting strip 28 may be installed in the base shoe 12. The continuous setting strip 28, typically made of plastic, is preferably of L-shaped configuration and supports and protects the glass panel 30 from contact with the

metallic walls of the base shoe 12. As such, the continuous setting strip 28 has a top arm 27 and a bottom arm 29 projecting perpendicularly from the top arm 27. In some embodiments, the top arm 27 and the bottom arm 29 may be two separate pieces. The continuous setting strip 28 improves upon the prior design disclosed in the '654 patent and '366 patents by replacing a plurality of individual setting blocks which formerly supported and protected the glass panel 30. The continuous setting strip 28 may be secured to the first inner wall 16 of the base shoe by a continuous tape strip 42. The continuous tape strip 42 improves upon the design shown in the '654 and '366 patents by eliminating the need to individually glue the formerly used setting blocks into place.

[0030] The improved base shoe 12 also features another continuous tape strip 40 placed on the top side 31 of the bottom arm 29 of the L-shaped surface of the continuous setting strip 28. The continuous tape strip 40 assists in securing the glass panel 30 to the continuous setting strip 28. The continuous tape strips 40, 42 may comprise double-sided adhesive tape.

[0031] As referenced above, the improved base shoe 12 of the present invention features dovetail grooves 22 formed into first inner side wall 16 and the second inner side wall 18 of the base shoe 12 near their respective top sides 15, 19. The dovetail groove 22 allows for the use of the safety weather seal 24 which will be typically located on an outboard facing side 33 of a fully assembled base shoe

assembly 10. The safety weather seal 24 is configured with two projections 44 which engage the interior side walls of the dovetail groove 22. Due to the nature of this design, the safety weather seal 24 must be inserted into the dovetail groove 22 prior to the insertion of a glass panel 30 into the base shoe 12, i.e. the weather seal 24 cannot properly be inserted in the base shoe 12 after installation of the glass panel 30. This design is advantageous from a safety viewpoint.

[0032] Frequently, glass walls will be installed at the border of drop-offs. With the previous press-in seal design (as referenced in the '366 and '654 patents), it has been observed that some installers have a habit of installing the weather seals as the last step in the installation. This requires an installer to lean over the glass wall to install the outboard weather seal which presents a safety risk. The new safety weather seal 24 eliminates this risk because it cannot be inserted after a glass panel 30 has been installed in the base shoe 12. Because the safety weather seal 24 must be installed prior to installation of a glass panel 30, it eliminates the risk of falling that occurs when an installer reaches over an installed railing to install the safety weather seal 24 at the outboard side of the glass panel to the base shoe interface.

[0033] With reference to Fig. 5, an enlarged perspective view of the safety weather seal 24 of the present invention base shoe assembly 10 is shown. The safety weather seal 24 includes a body section 46 having a top side 51, a bottom

side 53 opposite the top side 51, a lateral side 55 adjacent to the top side 51 and the bottom side 53, and a medial side 57 opposite the lateral side 55 and adjacent to the top side 51 and the bottom side 53. The lateral side 55 of the safety weather seal 24 interfaces with the first inner side wall 16 and the medial side 57 interfaces with the glass panel 30.

[0034] In the preferred embodiment, the bottom side 53 is non-parallel to the top side 51. Specifically, moving from the lateral side 55 to the medial side 57, the bottom side 53 may angle towards the top side 51. Therefore, the lateral side 55 may be taller than the medial side 57 as shown in Fig. 7. The body section 46 may further comprise one or more safety weather seal channels 59 extending the length of the body section 46 to facilitate compressibility of the body section 46.

[0035] Extending from the lateral side 55 of the body section 46 is a dovetail groove engagement portion 52 which terminates with a pair of opposing projections 44. The projections 44 are connected to the body section 46 by a stem 43. The projections 44 may form a 90 degree angle with the stem 43. In the preferred embodiment, the projections 44 form an oblique angle with the stem 43. More preferably, the projections 44 form an acute angle with the stem 43, thereby creating an arrow shape when viewed in cross-section.

[0036] The safety weather seal 24 also includes at least one glass scraper seal 50 protruding from the medial side 57. The embodiment shown in Fig. 5 comprises

three glass scraper seals 50. In the preferred embodiment, at least one of the glass scraper seals 50 may be angled towards the top side 51.

[0037] Figure 6 shows the safety weather seal 24 with four glass scraper seals 50. In addition, the bottom side 53, rather than being flat, is tapered.

[0038] On the lateral side 55, the safety weather seal 24 also includes a lateral lip 48 adjacent to the dovetail groove engagement portion 52. The lateral lip 48 covers a gap at the outboard glass panel 30 to base shoe 12 interface.

[0039] Fig. 7 is an enlarged perspective view of the press-in weather seal 26 of the present invention. The press-in weather seal 26 includes body section 61 having a top side 71, a bottom side 73 opposite the top side, a lateral side 75 adjacent to the top side 71 and the bottom side 73, and a medial side 77 opposite the lateral side 75 and adjacent to the top side 71 and the bottom side 73. The lateral side 75 of the press-in weather seal 26 interfaces with the second inner side wall 18. In the preferred embodiment, the bottom side 73 is tapered so as to narrow in cross-sectional width moving away from the top side 71.

[0040] Extending from the body section 61 on the lateral side 75 is a dovetail groove engagement portion 54 that may be pressed into the dovetail groove 22 on the second inner side wall 18 after a glass panel 30 has been installed in the base shoe 12. In some embodiments, the dovetail groove engagement portion 54 may project outwardly from the body section 61 at a right angle or upwardly towards the

top side 71.

[0041] The lateral side 75 of the press-in seal 26 further comprises a lateral lip 56, which covers any gap between the body section 61 and the inner side wall of the base shoe 12 when the dovetail groove engagement portion 54 is engaged with the dovetail groove 22.

[0042] The press-in weather seal 26 may also include a medial lip 60 projecting away from the body section 61 on the medial side 77 along the top side 71, which covers a gap at the glass panel 30 to base shoe interface. In the preferred embodiment, the medial lip 60 is angled upwardly away from the bottom side 73. The press-in weather seal 26 may also include one or more glass scraper seals 58 on the medial side 77, which seals the gap at the glass panel 30 to base shoe 12 interface. In the preferred embodiment, the glass scraper seals 58 may also be angled upwardly towards the top side 71 and away from the bottom side 73.

[0043] The body section 61 may further comprise one or more press-in weather seal channels 80 extending the length of the body section 61 to facilitate compressibility of the body section 61.

[0044] Fig. 8 shows the press-in weather seal 26 with additional dovetail groove engagement portions 54, as well additional glass scraper seals 58. In the preferred embodiment, the lowest dovetail groove engagement portion 54 and the lowest glass scraper seal 58 may transition into the tapered bottom side 73, thereby

forming an arrowhead shape as shown in Fig. 8.

[0045] The safety weather seal 24 and press-in weather seal 26 may be made from a variety of elastomeric compounds.

[0046] With reference to Figs. 9 and 10, additional features of the improved shoe assembly 10 of the present invention are shown while other components have been removed for clarity. Figs. 9 and 10 show the improved taper plates 62, which feature a continuous projection 64 along a top surface of the taper plate 62. The projection 64 rests in a recess 66 formed into the second inner wall 18 of the base shoe 12. The recess 66 has a recess depth 68 and a recess width 70. The taper plate 62, equipped with the projection 64, and the recess depth 68 of the recess 66, are configured such that there is a small gap 72 between the edge of the projection 64 and the second inner side wall of the base shoe 12. Experimentation has shown that a recess width 70 of 1/32 inch and a recess depth 68 of 5/16 inch are suitable dimensions for the recess 66. The projection 64 in combination with the gap 72 between the projection and the interior face of the second side wall 18 of the base shoe 12 provides a prying surface that allows an installer to insert a prying device into the gap and pry the against the projection 64 to separate the taper plate 62 from the second side wall of the base shoe 12.

[0047] The show assembly may also comprise a groove cover 79 for when the dovetail grooves are not in use. The groove cover 79 can be placed over the

dovetail grooves 22 and may extend along the full length of the dovetail groove.

[0048] With reference to Fig. 10, with regard to the recess depth 68 of the recess 66 on the second inner side wall 18 of the base shoe 12, a depth of 5/16 inch to 3/8 inch has been found by experimentation to work well with the improved base shoe 12 and taper plate 62 of the present invention. The recess depth 68 also allows for the use of larger more effective weather seals.

[0049] With reference to Fig. 4, a representation of decorative cladding 14 which may be placed on the improved base shoe 12 of the present invention is shown. The decorative cladding will typically be made from stainless steel, brass, anodized aluminum or other material having a visually attractive surface finish.

[0050] The foregoing detailed description and appended drawings are intended as a description of the presently preferred embodiment of the invention and are not intended to represent the only forms in which the present invention may be constructed and/or utilized. Those skilled in the art will understand that modifications and alternative embodiments of the present invention which do not depart from the spirit and scope of the foregoing specification and drawings, and of the claims appended below are possible and practical. It is intended that the claims cover all such modifications and alternative embodiments.

[0051] The invention may be industrially applied to the development, manufacture, and use of an improved shoe assembly for installation of panels, such

as glass panels in a safe and efficient manner that not only protects the panel during installation, but also the installer. The configuration of the safety weather seal forces the installer to install the safety weather seal prior to the installation of the panel. The configuration of the press-in weather seal allows the press-in weather seal to be installed after the installation of the panel.

We claim:

1. A shoe assembly, comprising:
 - a) a base shoe, the base shoe comprising:
 - i. a first inner side wall having a top side and a bottom side,
 - ii. a second inner side wall having a top side and a bottom side,
 - iii. a bottom wall adjacent to the bottom side of the first inner side wall and the bottom side of the second inner side wall, the first inner side wall, the second inner side wall, and the bottom wall defining a base shoe channel,
 - iv. a first dovetail groove formed in the first inner side wall adjacent to the top side of the first inner side wall, and
 - v. a second dovetail groove formed in the second inner side wall adjacent to the top side of the second inner side wall; and
 - b) a press-in weather seal, the press-in weather seal comprising:
 - i. a body section having a top side, a bottom side opposite the top side, a lateral side adjacent to the top side and the bottom side, and a medial side opposite the lateral side and adjacent to the top side and the bottom side, and
 - ii. a dovetail groove engagement portion extending from the body section on the lateral side for engaging the second dovetail groove, and
 - iii. a plurality of channels extending a length of the body section;
 - c) a continuous setting strip comprising a top arm and a bottom arm projecting perpendicularly from the top arm and a centrally located channel for the receipt of a first continuous tape strip wherein the first continuous tape strip secures the continuous setting strip to the base shoe; and
 - d) a second continuous tape strip mounted on the bottom arm of the continuous setting strip.

2. The shoe assembly of claim 1, wherein the press-in weather seal further comprises a lateral lip for covering a gap between the body section and the second inner side wall of the base shoe when the dovetail groove engagement portion is engaged with the second dovetail groove.

3. The shoe assembly of claim 1, wherein the press-in weather seal further comprises a medial lip projecting away from the body section at the top side of the body section of the press-in weather seal.

4. The shoe assembly of claim 1, wherein the press-in weather seal further comprises at least one glass scraper seal extending from the medial side.

5. The shoe assembly of claim 1, wherein the bottom side of the press-in weather seal is tapered.

6. The shoe assembly of claim 1, further comprising a safety weather seal, the safety weather seal comprising:

a. a body section having a top side, a bottom side opposite the top side, a lateral side adjacent to the top side and the bottom side, and a medial side opposite the lateral side and adjacent to the top side and the bottom side, and one or more safety weather seal channels extending a length of the body section, wherein the bottom side is tapered;

b. a dovetail groove engagement portion extending from the lateral side of the body section, the dovetail groove engagement portion terminating at a pair of angled, opposing projections which form an arrow shape;

c. a lateral lip protruding from the top side of the body section on the outboard side adjacent to the dovetail groove engagement portion; and

d. at least one glass scraper seal protruding from the medial side.

7. A shoe assembly, comprising:
 - a. a base shoe, the base shoe comprising:
 - i. a first inner side wall having a top side and a bottom side,
 - ii. a second inner side wall having a top side and a bottom side,
 - iii. a bottom wall adjacent to the bottom side of the first inner side wall and the bottom side of the second inner side wall, the first inner side wall, the second inner side wall, and the bottom wall defining a base shoe channel,
 - iv. a first dovetail groove formed in the first inner side wall adjacent to the top side of the first inner side wall, and
 - v. a second dovetail groove formed in the second inner side wall adjacent to the top side of the second inner side wall;
 - b. a continuous setting strip comprising a top arm and a bottom arm projecting perpendicularly from the top arm and a centrally located channel for the receipt of a first continuous tape strip wherein the first continuous tape strip secures the continuous setting strip to the base shoe;
 - c. a second continuous tape strip mounted on the bottom arm of the continuous setting strip;
 - d. a safety weather seal, comprising:
 - i. a body section having a top side, a bottom side opposite the top side, a lateral side adjacent to the top side and the bottom side, and a medial side opposite the lateral side and adjacent to the top side and the bottom side, and one or more safety weather seal channels extending a length of the body section, wherein the bottom side is tapered;
 - ii. a dovetail groove engagement portion extending from the lateral side of the body section, the dovetail groove engagement portion terminating at a pair of opposing projections for engaging the first dovetail groove;

- iii. a lateral lip protruding from the top side of the body section on the lateral side adjacent to the dovetail groove engagement portion;
 - iv. at least one glass scraper seal protruding from the medial side; and
- e. a press-in weather seal, the press-in weather seal comprising:
- i. a body section having a top side, a bottom side opposite the top side, a lateral side adjacent to the top side and the bottom side, and a medial side opposite the lateral side and adjacent to the top side and the bottom side, wherein the bottom side is tapered;
 - ii. a dovetail groove engagement portion extending from the body section on the lateral side;
 - iii. a lateral lip for covering a gap between the body section and the second inner side wall of the base shoe when the dovetail groove engagement portion is engaged with the second dovetail groove;
 - iv. a medial lip projecting away from the body section on the medial side at the top side of the body section of the press-in weather seal;
 - v. at least one scraper seal extending from the medial side;
 - vi. at least one press-in weather seal channel extending a length of the body section.

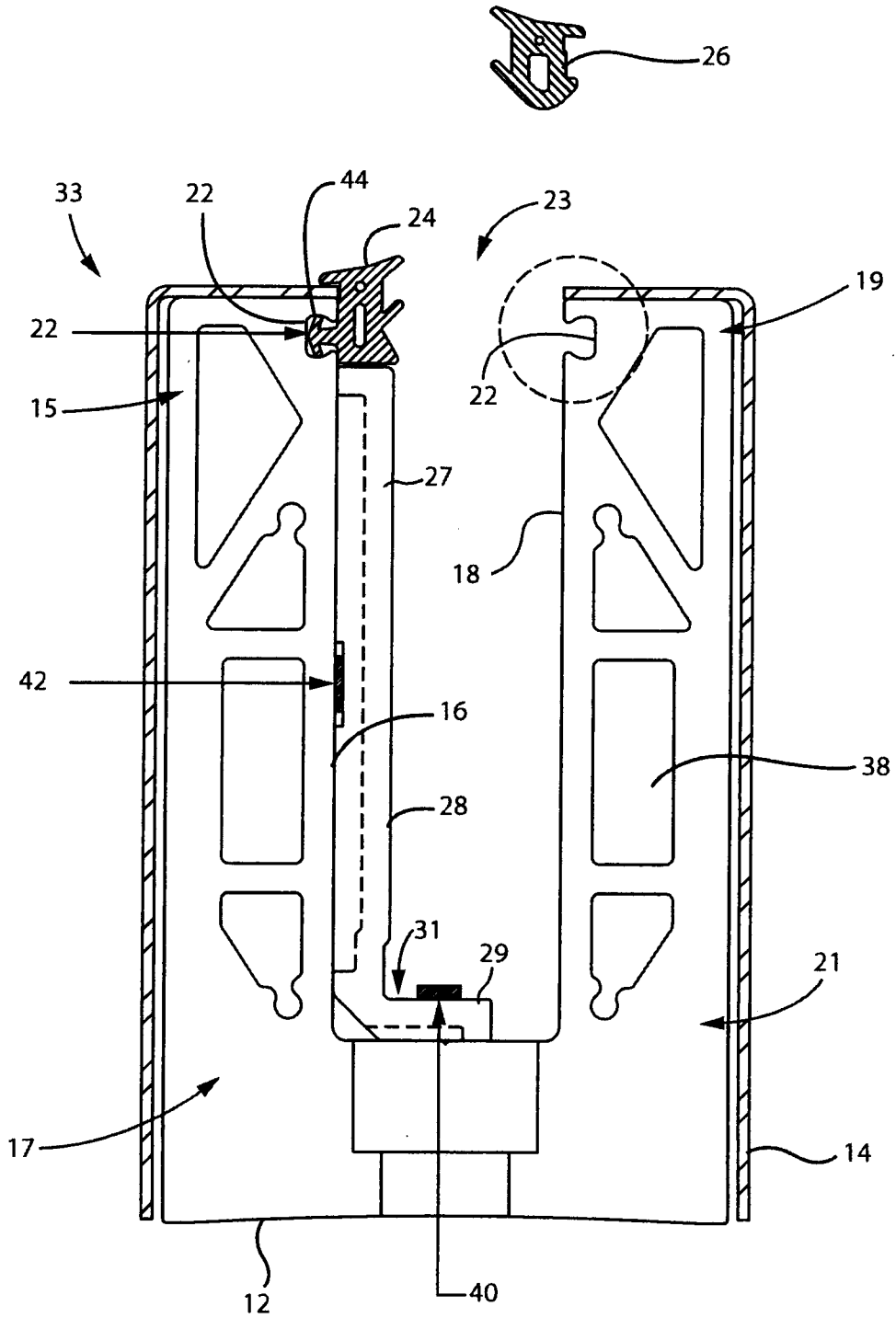

Fig. 1

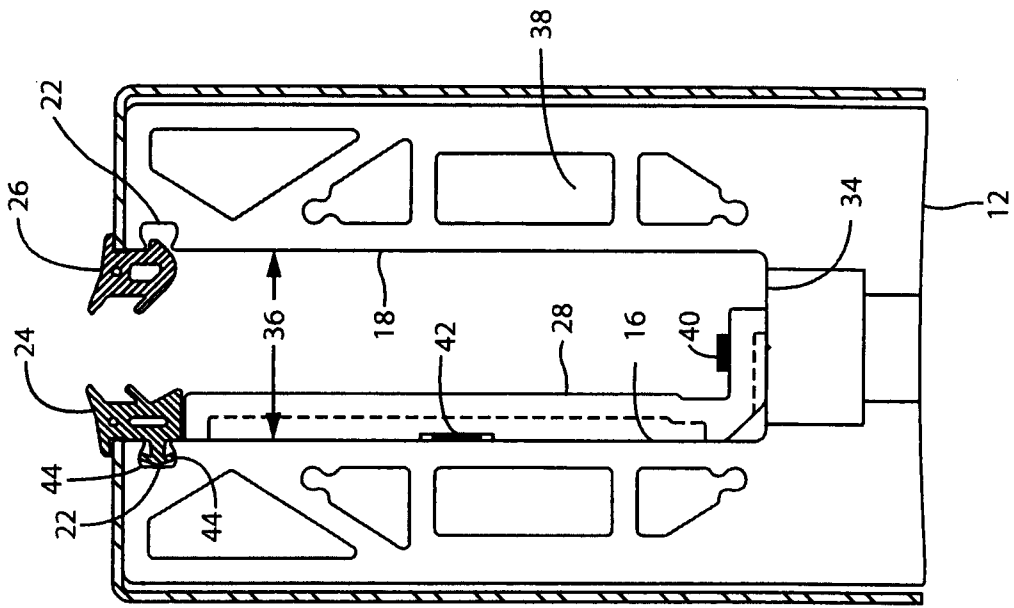

Fig. 2

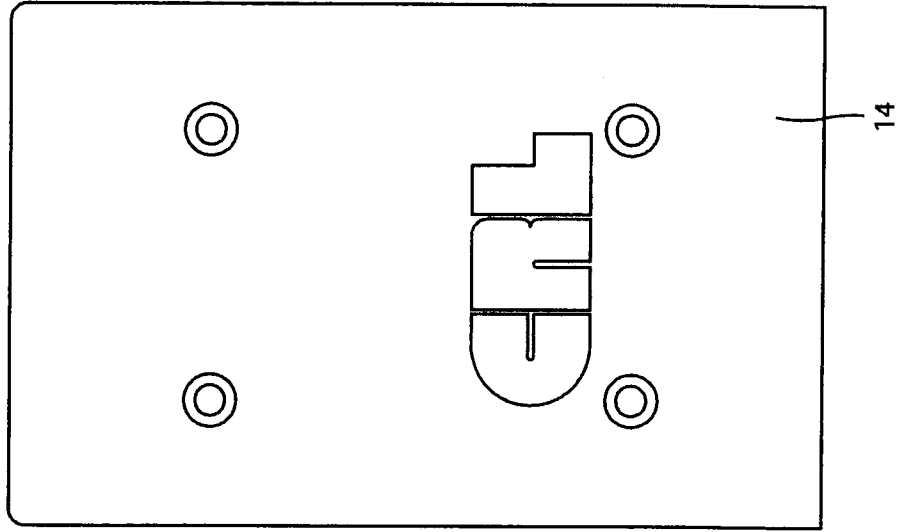

Fig. 3

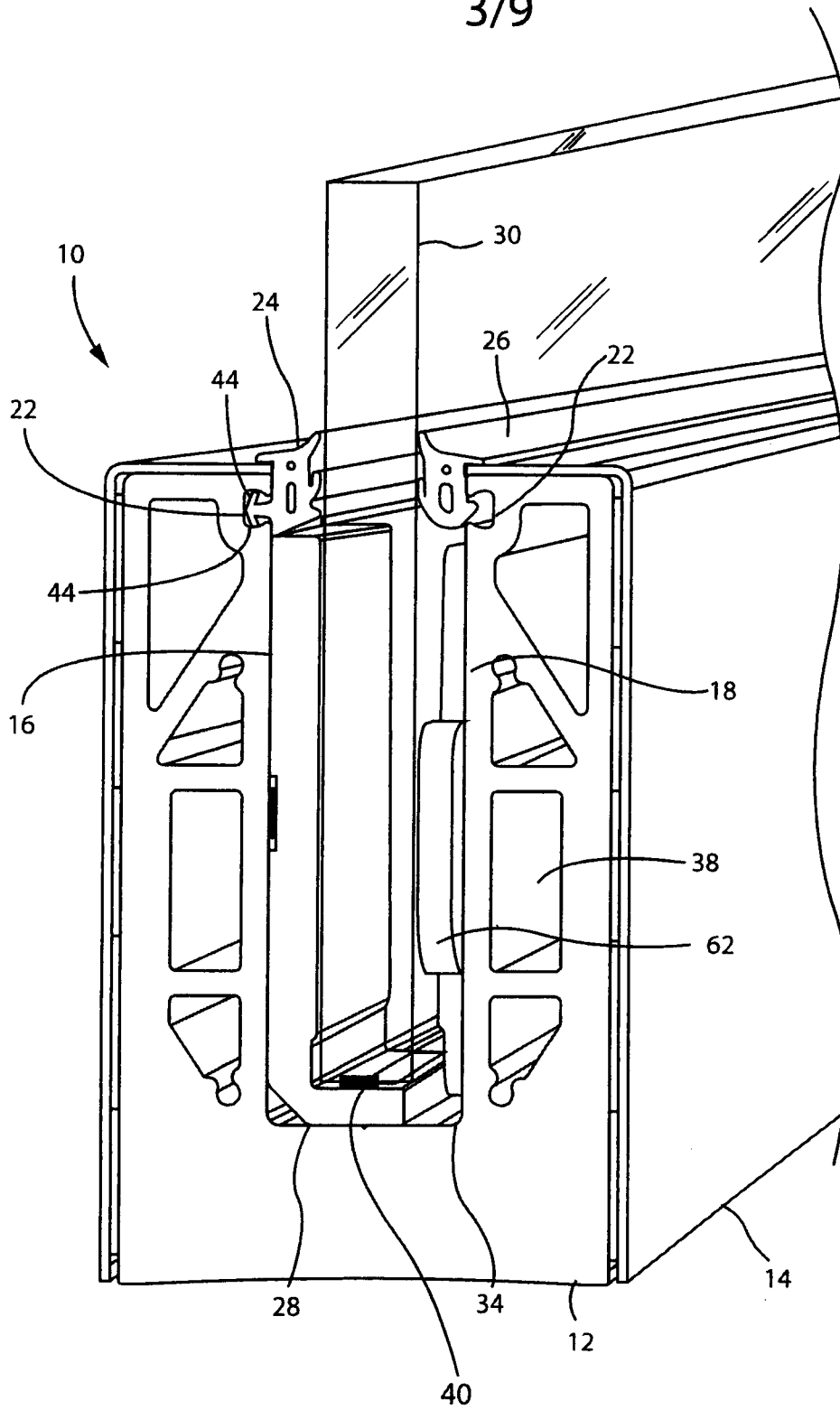

Fig. 4

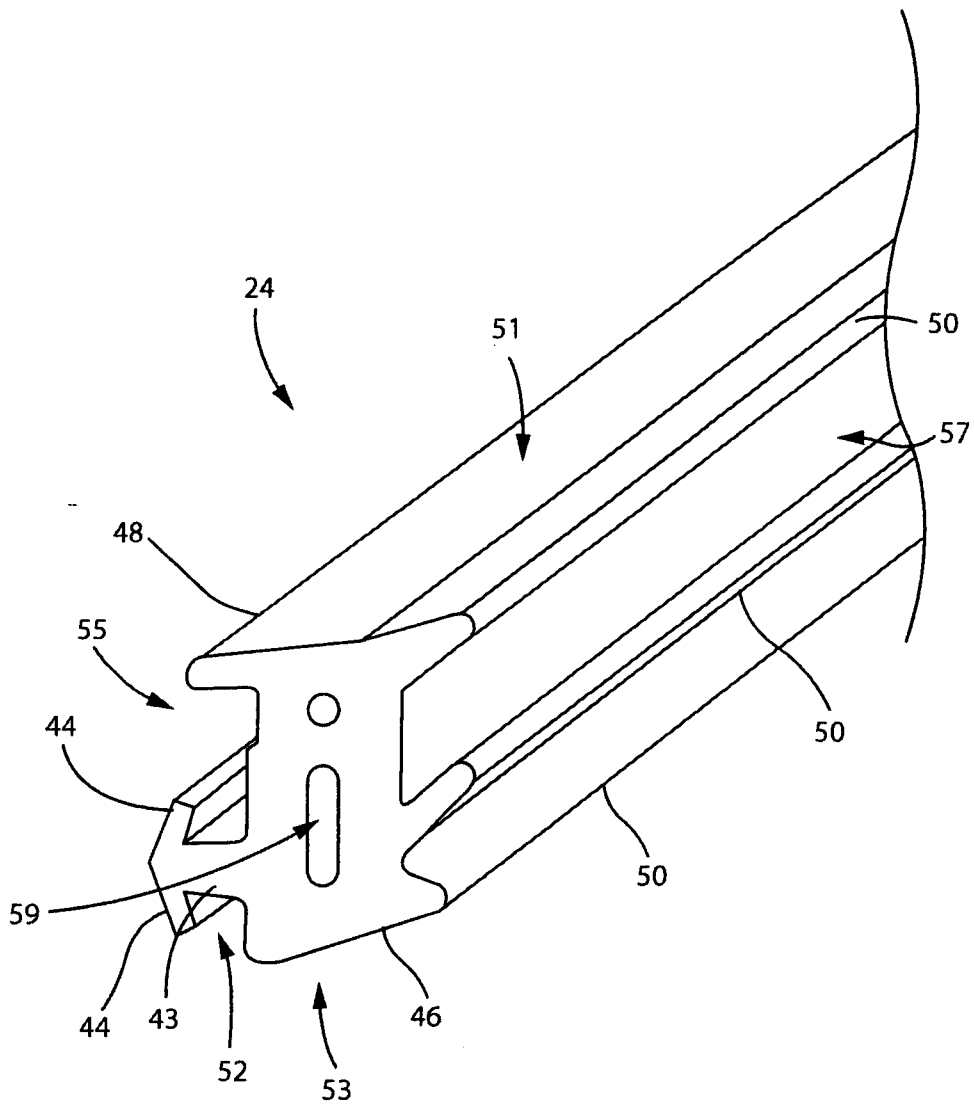

Fig. 5

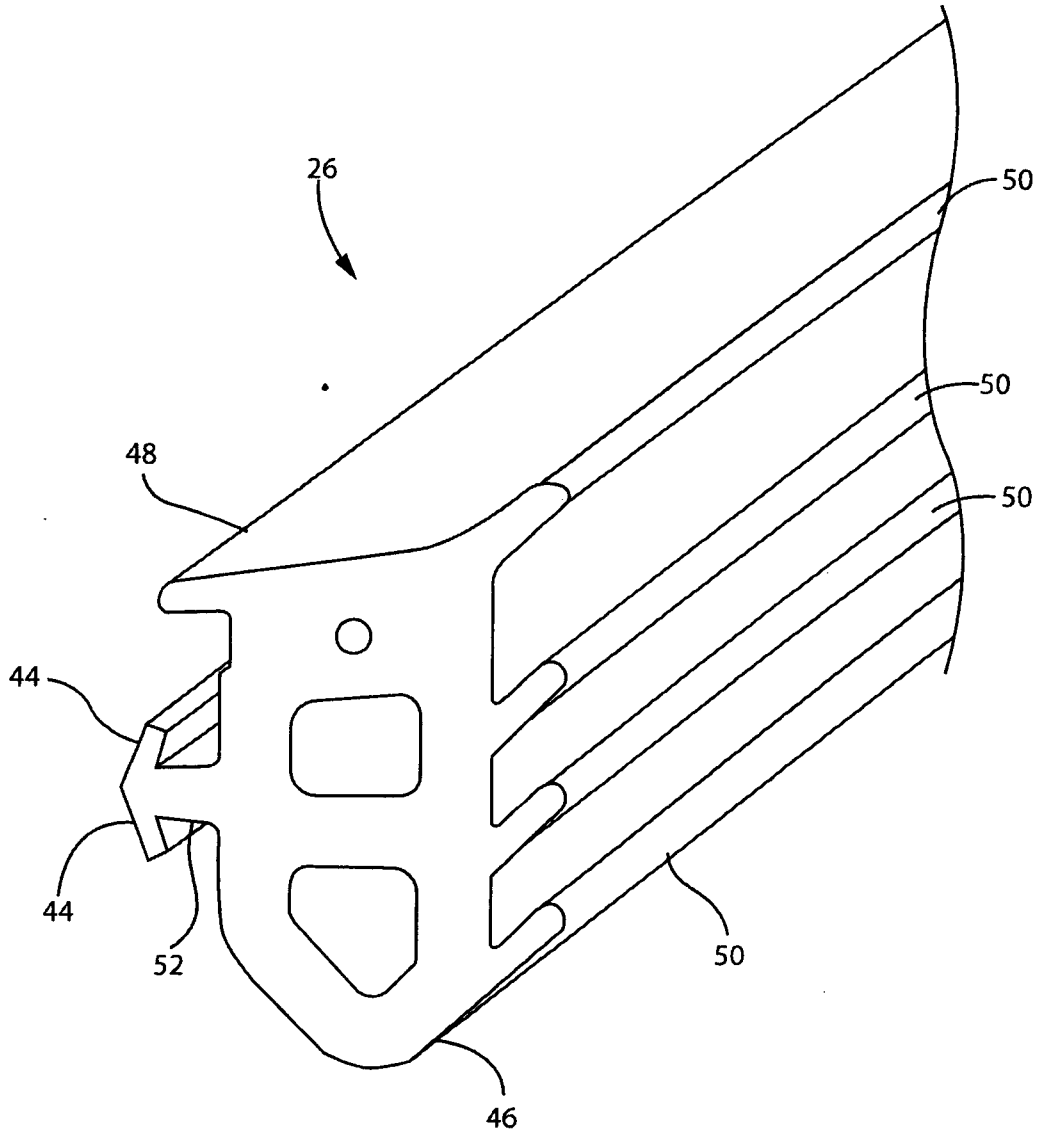

Fig. 6

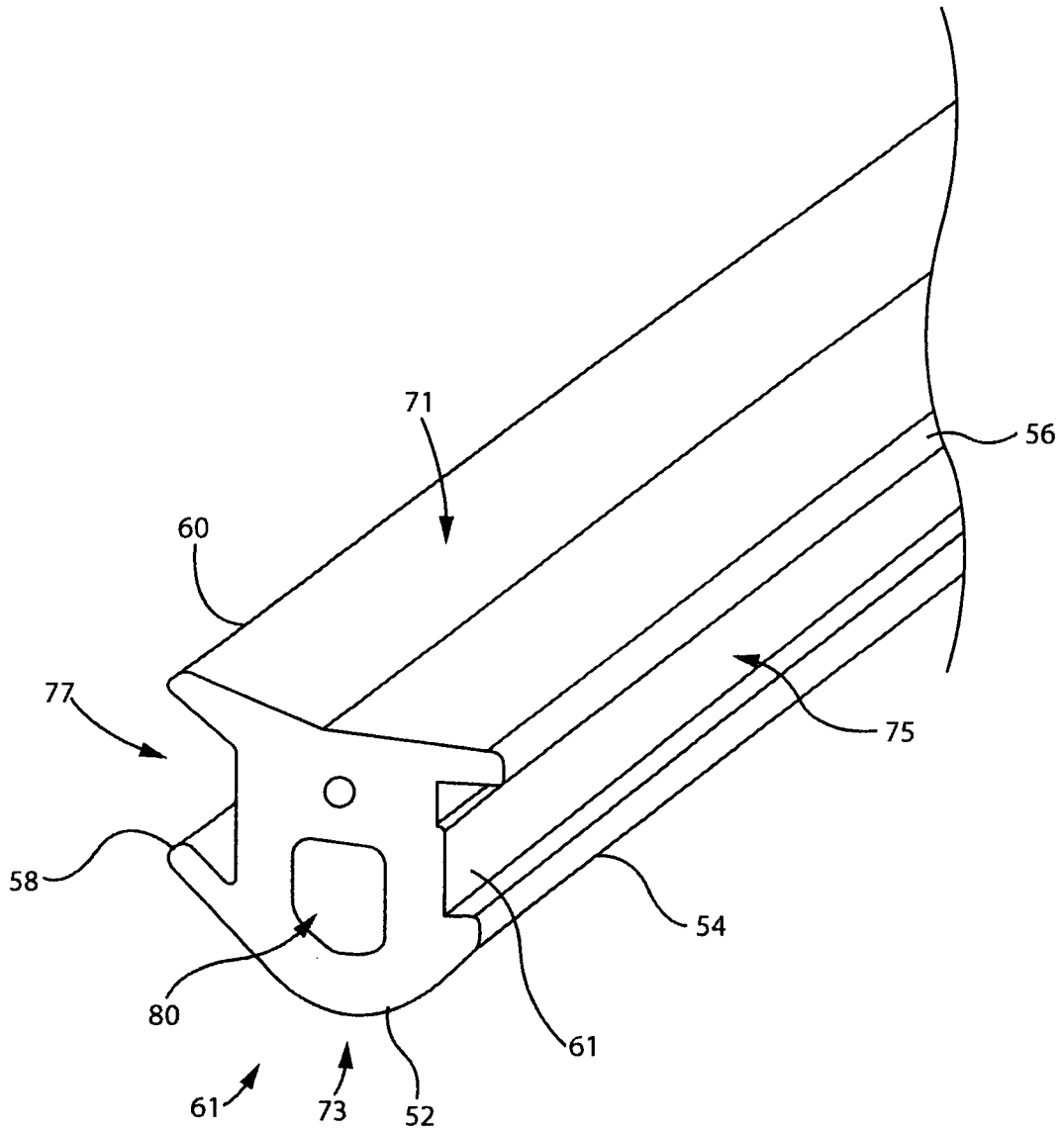

Fig. 7

7/9

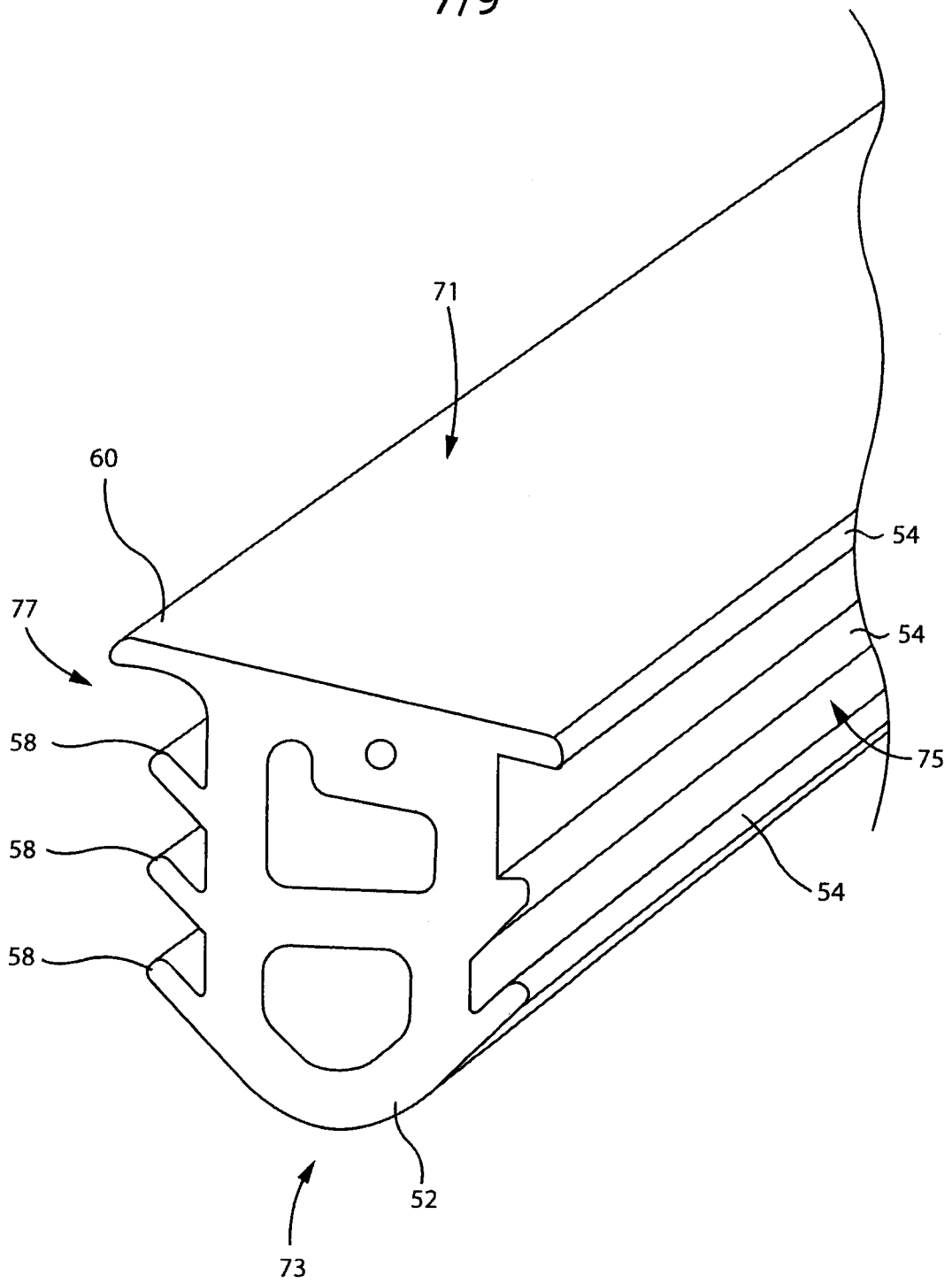

Fig. 8

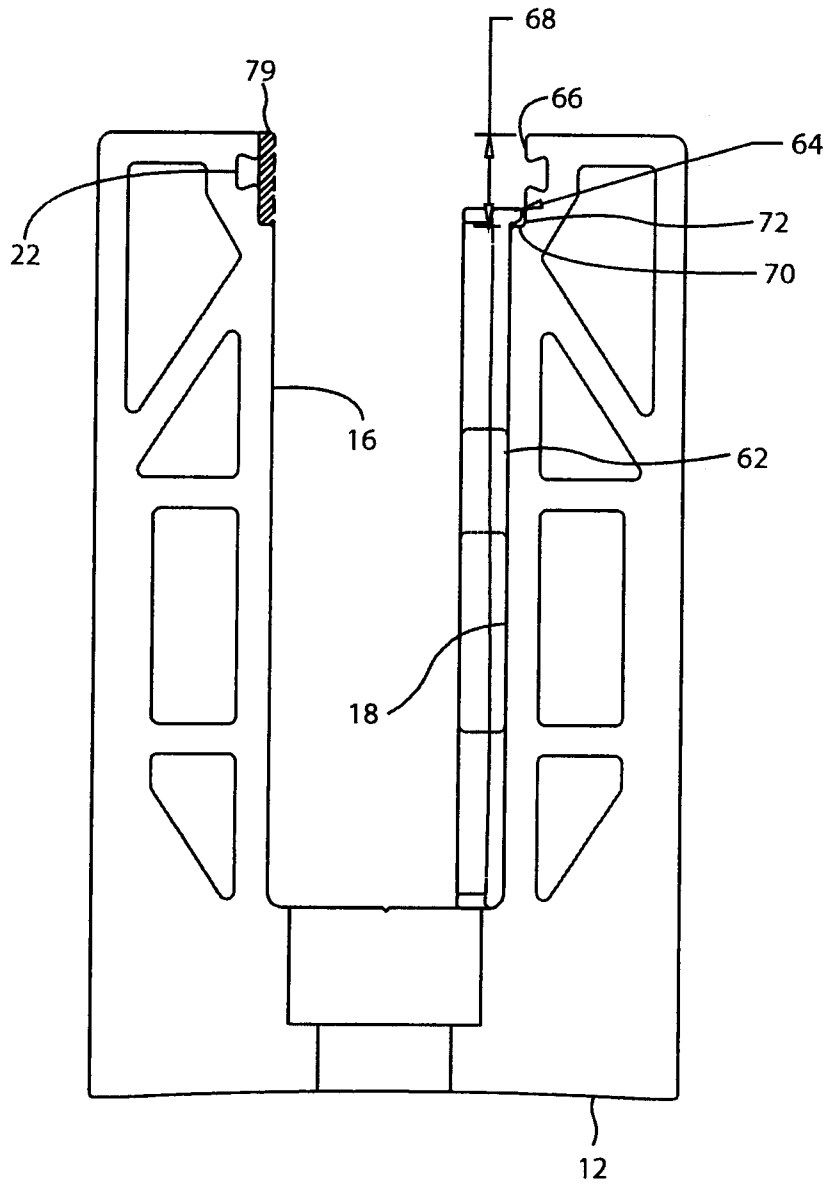

Fig. 9

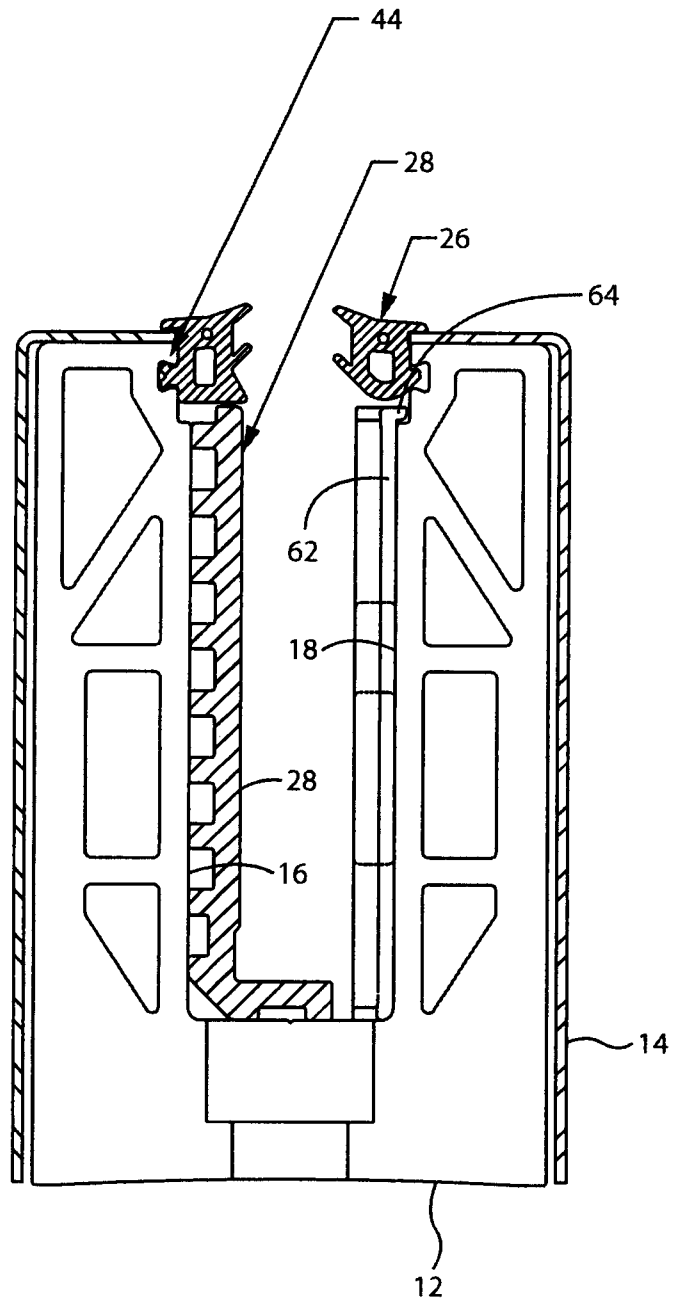

Fig. 10

