

(No Model.)

W. C. NELSON.
CAR COUPLING.

No. 521,545.

Patented June 19, 1894.

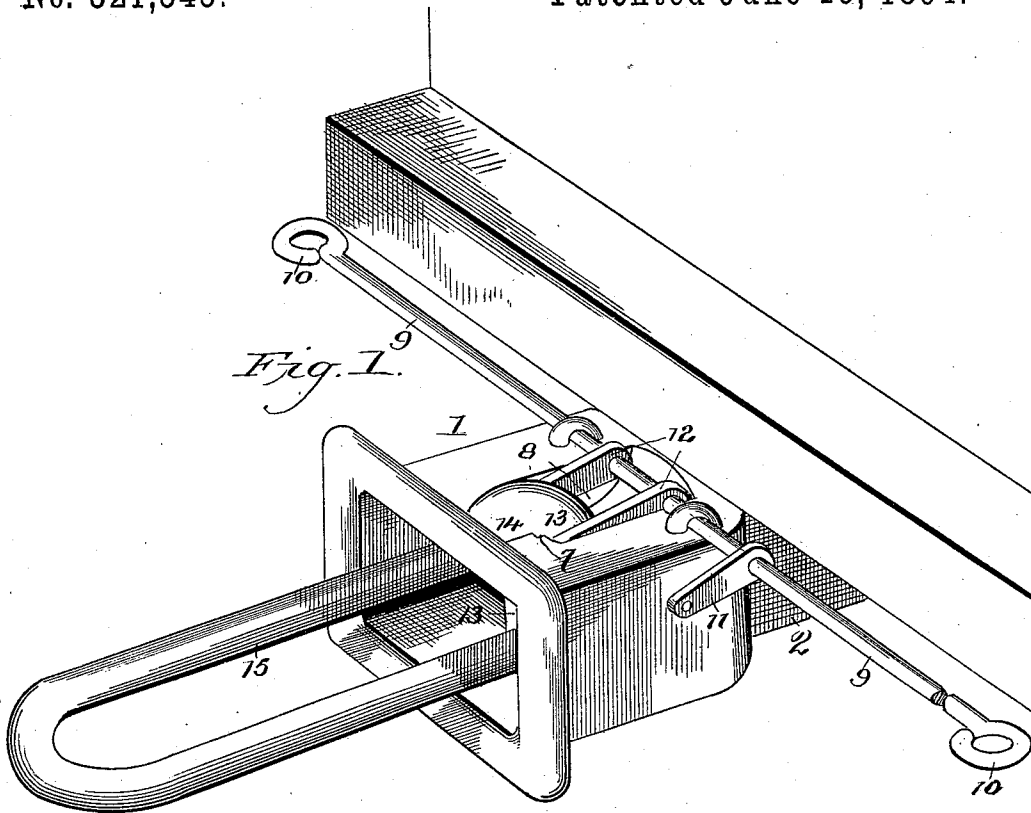

Fig. 1.

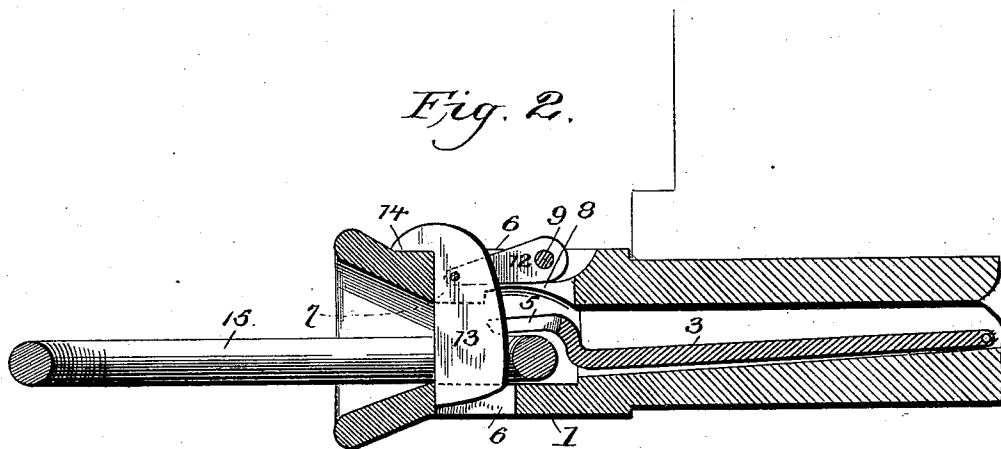

Fig. 2.

Witnesses
J. W. Reynolds
Chas. E. Fryer

Inventor
William C. Nelson
By *John Wedderburn*
Attorney

UNITED STATES PATENT OFFICE.

WILLIAM C. NELSON, OF SANTA ROSA, CALIFORNIA.

CAR-COUPLING.

SPECIFICATION forming part of Letters Patent No. 521,545, dated June 19, 1894.

Application filed February 23, 1894. Serial No. 501,218. (No model.)

To all whom it may concern:

Be it known that I, WILLIAM C. NELSON, a citizen of the United States, residing at Santa Rosa, in the county of Sonoma and State of California, have invented certain new and useful Improvements in Car-Couplers; and I do hereby declare the following to be a full, clear, and exact description of the invention, such as will enable others skilled in the art to which it appertains to make and use the same.

This invention relates to car couplings, and has for its object to simplify the construction and arrangement of such devices and to render them more positive in their action and easy to couple in automatic manner, as well as be readily uncoupled when desired, as it will obviate the serious defects arising from jamming in collisions.

With these and other objects in view, the invention consists of the construction and arrangement of the several parts, which will be more fully hereinafter described and claimed.

In the drawings: Figure 1 is a perspective view of a car coupler, embodying the invention, and shown applied to the end of a car. Fig. 2 is a central longitudinal vertical section of the device.

Similar numerals of reference are employed to indicate corresponding parts in the several views.

Referring to the drawings, the numeral 1 designates a draw-head of suitable form, which has a rearwardly extending draw-bar 2 formed hollow and having therein a pivotally mounted link guard 3 consisting of an elongated bar which is pivoted at its rear end and extends through the draw bar into the rear portion of the draw head slot or opening and at its front end is struck upward and provided with divergent arms 5 which are arranged at an oblique angle to a horizontal plane and have their under sides to conform to the upper surface of one end of the link. This device holds the end of the link in engagement with the draw head down in its horizontal position, and obviates and prevents too free movement of the link and also holds the link in proper horizontal position when coupling with another draw head. The bar 3 is gravitating in its nature, and no springs or other retractile devices are employed, and is therefore not lia-

able to become disarranged. The upper surface of the draw head as well as the lower surface is formed with a slot 6 said bolts being in alignment and the upper slot having a slight forward recess 7 and at the bottom on opposite sides of the said upper slot adjacent to the said recess are flanges 8. Extending transversely across the rear of the upper surface of the draw head is a rotatable rod 9 mounted in suitable bearings and having at its opposite end loops or eyes 10 which form handles to which operating devices may be attached, and adjacent to one of said loops or eyes is an arm 11, to which a rod or chain or other operating device may be attached and extended to the upper portion of a freight car. Between the bearings of the said rotatable rod two arms 12 are secured thereto and arranged parallel and project upwardly from said rod and have movement in the upper slot. Between the forward portions of the said arms 12 is pivotally secured a gravitating dog 13, which has an upper shoulder 14 adapted to rest on the central front portion of the draw head and when the dog is down in coupling position, the arms 12 rest upon the flanges at the lower front portion of the upper slot 6. The dog when in coupling position, enters the recess of the upper slot 6. The lower portion of the said dog is increased in width to reinforce the same, and this increased width of the dog requires the formation of a recess at the front of the upper slot 6 of the draw head. When the dog is down in coupling position it passes through the lower slot 6 of the draw head and the link, and thereby is held in a substantially rigid manner and is less liable to breakage. The link 15 used in this instance is of ordinary form, and in practice, the said link, in striking the front edge of the dog will raise the same and pass into the draw head, the dog afterward dropping through the opening in the link and automatically securing the said link in connection with the draw head. In uncoupling the car the dog may be raised from either one side or the other and also from the top of a car where the coupling is applied to box cars.

The movement of the link is sufficient to allow enough play in turning curves or to compensate for the movement of the cars and the automatic coupling operation obviates the

necessity of persons going between the two cars and thereby rendering the device safe as well as accurate in its operation.

5 It is apparent that many minor changes in the construction and arrangement of the several parts might be made and substituted for those shown and described, without in the least departing from the nature or spirit of the invention.

10 Having thus described the invention, what is claimed as new is—

15 In a car coupling, the combination of a draw-head having slots in the upper and lower portions thereof, the upper slot having opposite side flanges and a forwardly extending recess, a rotatable cross rod at the rear of the upper portion of the draw-head projecting outwardly therefrom and having operating means in connection therewith, a pair of parallel arms secured to the said rod and located over the opposite side flanges and in the up-

per slot, a dog pivoted between the said arms and provided with upper front shoulder to extend over the upper front portion of the draw-head in advance of the upper slot, the lower portion of the said dog being widened, and a gravitating link holder consisting of a link bar extending through the draw bar and having a pivotal connection at its rear end and an upwardly extending bend at the front end provided with divergent arms arranged at an oblique angle to a horizontal plane, the under side of the same conforming to the shape of one end of a link, substantially as and for the purposes specified. 25 30 35

In testimony whereof I have signed this specification in the presence of two subscribing witnesses.

WILLIAM C. NELSON.

Witnesses:

W. F. RUSSELL,
A. W. ARNOLD.