



Europäisches Patentamt  
European Patent Office  
Office européen des brevets



(11) **EP 0 616 658 B2**

(12) **NEW EUROPEAN PATENT SPECIFICATION**

(45) Date of publication and mention  
of the opposition decision:

**23.05.2001 Bulletin 2001/21**

(45) Mention of the grant of the patent:

**08.10.1997 Bulletin 1997/41**

(21) Application number: **92923900.2**

(22) Date of filing: **23.11.1992**

(51) Int Cl.7: **E03C 1/046**

(86) International application number:  
**PCT/GB92/02165**

(87) International publication number:  
**WO 93/10311 (27.05.1993 Gazette 1993/13)**

(54) **HAND WASHING UNIT**

HANDWASCHANLAGE

UNITE DE LAVAGE POUR LES MAINS

(84) Designated Contracting States:  
**AT BE CH DE DK ES FR GB GR IE IT LI NL SE**

(30) Priority: **22.11.1991 GB 9124819**

(43) Date of publication of application:  
**28.09.1994 Bulletin 1994/39**

(73) Proprietor: **Polar Bay Limited**  
**Douglas, Isle of Man (GB)**

(72) Inventor: **FOSTER, Frank**  
**London SW15 1BJ (GB)**

(74) Representative:  
**Bankes, Stephen Charles Digby et al**  
**BARON & WARREN**  
**18 South End**  
**Kensington**  
**London W8 5BU (GB)**

(56) References cited:  
**EP-A- 0 396 039**                    **US-A- 3 639 920**  
**US-A- 4 398 310**                    **US-A- 4 942 631**  
**US-A- 5 031 258**

**EP 0 616 658 B2**

## Description

**[0001]** This invention relates to a device for washing and rinsing hands, and is particularly suitable for use in premises where food is prepared or in other premises where regular hand washing is essential and needs to be monitored.

**[0002]** Hand washing units are known which include proximity sensors which automatically switch on a water supply when hands are inserted into a wash basin, thereby avoiding the need for manual contact with any taps or switches and thus reducing the risk of cross-contamination. In one known type of unit, the washing water supplied has a hand washing detergent or disinfectant component dissolved in it, for example an iodophor.

**[0003]** Hygiene regulations in premises such as restaurants, shops and factories in which food is handled have become increasingly stringent in recent years. Generally, the management is held responsible for ensuring that all employees wash their hands properly, for example after using the lavatory, before returning to work. It is however difficult for hand washing regulations to be properly enforced unless it can be comprehensively monitored. In particular, although an employee may be seen to visit a wash basin it is difficult to ensure that he does more than run his fingers under the tap. Also, it is difficult to ensure that soap is used during each hand wash, or indeed to provide soap which can be used without the risk of cross-contamination.

**[0004]** This problem is solved by means of a hand washing and rinsing unit as described in Claim 1.

**[0005]** In a preferred embodiment of the invention, the supply of water and soap is controlled by timing relays triggered by a proximity sensor so that water flows for an initial period of a few seconds after which soap is fed to the mixing valve for a few seconds, for example by means of a dosing pump, and thereafter water continues to flow for a period of for example 30 to 40 seconds to enable the soap to be rinsed off.

**[0006]** The electronic monitoring system, which records each hand wash, may for example be operated by means of user codes, so as to record the number of times each person working on the premises uses the hand wash unit during the course of a day. The system can be linked to a computer which records the name of each person using the unit and the time and duration of each use.

**[0007]** In a simpler system, the proper use of the unit may be arranged simply to trigger a counter so as to indicate to the management the frequency of use. The counter is arranged not to register a use until soap has been dispensed.

**[0008]** Preferred embodiments of the invention will now be described with reference to the accompanying drawings wherein:

FIG. 1 is a partially cutaway front view of a hand washing and rinsing unit having conventionally

placed proximity sensors;

FIG. 2 is a part sectional view along the line II-II in Fig. 1;

FIG. 3 is a schematic diagram showing how the parts of the system of Figs. 1 and 2 interconnect; and

FIG. 4 is a perspective view of a hand washing and rinsing unit in accordance with the invention.

**[0009]** Referring first to Figs. 1 and 2, a hand wash unit comprises a basin 12 which may suitably be made from stainless steel but could for example be made from aluminium or glass fibre reinforced plastics. The basin is secured to a housing 10, suitably of the same material, by means of screws 11 which pass through overlapping flanges 13 on each side of the basin.

**[0010]** The housing 10 is provided with means (not shown) for securing it to a wall. The wash basin 12 is provided with a conventional waste water outlet 14 and sink trap 15.

**[0011]** The supply of water to the basin is by way of a mixer valve 16 through which passes water from an inlet pipe 18 and which is arranged when required to mix into the water a predetermined quantity of a liquid soap fed in through a conduit 24.

**[0012]** The water pipe 18 is fed by a cold water supply 21 and a hot water supply 23, both of which pass through a thermostatically controlled mixer 22 which can be pre-set to supply water to the basin at a suitable hand washing temperature such as 40 to 50°C. The thermostatic control 22 is preferably of a fail-safe type so as to avoid scalding.

**[0013]** From the thermostatic mixer, the water flows at the required temperature through an electrically controlled solenoid valve 20 which is arranged to turn the supply on and off in response to control mechanisms to be described in more detail below.

**[0014]** Liquid soap is supplied from a container 28 to the inlet conduit 24 by means of an electrically operated chemical dosing pump 26 which is arranged to be switched on and off by a central control system described below, in accordance with a predetermined programme.

**[0015]** On each of the inner side walls 29 of the basin there is provided an infrared proximity sensor 30. Between them these two sensors can detect when hands are inserted into the basin and send an electrical signal to the central control system to switch on the water supply.

**[0016]** The central control for the system, generally indicated by 32, may suitably be provided on a printed circuit board secured to the rear wall of the unit, with suitable protection against water leaks.

**[0017]** The operation of the system will now be described in more detail with reference to Fig. 3.

**[0018]** As shown in Fig. 3, the central control unit 32 is supplied by a mains transformer 36 which in turn is connected to an ordinary AC mains supply. The trans-

former also provides the power necessary for the soap dosing pump 26. Connected to the unit 32 are the dosing pump 26, a user code input panel 34, the proximity sensors 30 and the solenoid valve 20. An output line 40 from the control unit is connected to a computer with a display screen and printer.

**[0019]** With the system switched on at the main by means of a main switch 39, an employee, for example in a restaurant or food processing factory, keys in a personal code number by pressing buttons on the panel 34. This code is recorded by the monitoring computer via connection 40 and the system is then set to operate. Instead of a keyboard input, the unit 34 could comprise a magnetic strip reader operated by personal user cards.

**[0020]** With the system activated, the employee inserts his hands into the wash basin 12, causing one or both of the proximity sensors 30 to send a signal to the control unit 32. This activates a series of timer relays and first operates the solenoid valve 20 to switch on the water supply via the mixer unit and nozzle 16.

**[0021]** After an initial "wetting" period of for example five to eight seconds, a second timer relay switches on the dosing pump 26 to supply liquid soap to the mixer unit 16 so that a soap solution is fed on to the users hands. The initial running period will have shown the user where the water jet is, ensuring that none of the soap need be missed and thus flushed unused down the waste pipe. The flow of soap continues for a period of for example four to six seconds. The pump 26 is then switched off but water continues to flow into the basin for a period of some 25 to 40 seconds to enable the hands to be washed properly and rinsed. If during this time the hands are withdrawn from the basin, for example to brush finger nails, the supply cycle will be interrupted, but will be started again from the same point when the hands are reinserted, dispensing water only. At the end of the washing cycle the solenoid valve 20 is switched off and the unit is ready for another user.

**[0022]** The whole washing cycle is monitored by the central computer via the line 40. This will record the name of the user, as indicated by the user code keyed in, and will also record the time of use. If the central computer is monitoring more than one unit (and it could of course be monitoring a large number of units throughout the building) it will also record the location of the unit used. The computer will also record the total duration of the time during which the user's hands were in the basin. If for example the user simply inserts his hands for a few seconds, not long enough to start the soap supply, he will not be recorded as having washed his hands at all. Having held his hands in the basin long enough to receive the soap solution, the user will have little choice but to hold them there long enough to rinse the soap off again.

**[0023]** The computer record can be monitored by the person responsible, who can for example get the computer to print out a list of "defaulters" who have either

not used the system or have used it for a period insufficient to effect a proper wash.

**[0024]** In order to prevent the mixer unit 16 from becoming clogged with soap, for example by drying of the liquid soap during an extended period of closure, the system can be set to flush the unit through with water at predetermined intervals, for example two hours. This flushing could also if desired be set to inject into the system a dose of a suitable disinfectant so as to keep the mixer head and the waste outlet free from microbial contamination.

**[0025]** Figure 4 shows a perspective view from below of a simplified wash and rinse unit in accordance with the invention. This unit is designed to be positioned above a separate wash hand basin, which may be of conventional design. The unit comprises a housing 50 containing the soap supply, valves and other components, which may be broadly as described in connection with Figures 1 to 3. The housing has a forwardly projecting hood 52 on the underside of which are provided a water outlet 56, a soap dispensing outlet 58 and an infrared sensor 60. It will be noted that in this case the soap and water are supplied separately, albeit through adjacent outlets, rather than through a mixing valve. They are however sufficiently close to ensure that if the hands are placed below the water outlet they will also catch the soap when it is dispensed.

**[0026]** Pipes 53 and 54 entering the housing at the bottom supply hot and cold water to the device.

**[0027]** Positioned on the top of the housing is a digital counter 62, arranged to register one wash each time the soap dispenser operates.

**[0028]** As in the case of the embodiments of Figures 1 to 3, when hands are positioned below the water outlet 56, the infrared proximity sensor switches on the water supply through the outlet 56, the water being maintained at a suitable temperature such as 40°-50°C by a thermostatic control. When the water has run for a period of a few seconds, suitably for 5 to 8 seconds, a valve is automatically actuated to dispense a measured quantity of liquid soap through the outlet 58. Once this has happened, and the user has soap on his hands, the counter 62 registers one wash as having taken place since the flow of water will continue and the user will have to keep his hands under the water supply until the soap has been washed off.

**[0029]** A warning light may be provided, to be illuminated when the soap is dispensed.

**[0030]** In order to ensure that soap is always available, the soap reservoir, which may suitably hold 3 to 5 litres of liquid soap, preferably incorporates a detector arranged to be actuated when the soap level falls below a preset minimum such as 0.5 litres. The detector can be arranged to operate a low soap warning light to alert staff. to top up the soap reservoir. Should the warning light be ignored and the soap reservoir run dry, the warning system may for example be arranged to flash or illuminate a verbal message, and to shut down the sys-

tem so that neither soap nor water is available. Such an event preferably also triggers a signal elsewhere, for example, in the manager's office so that action can immediately be taken.

5

### Claims

1. A hand washing and rinsing unit for a wash basin, comprising a water supply (53), a water outlet (56) with a water supply (53, 54) thereto, means (20, 32, 60) for automatically switching on the water supply when hands are inserted below the water outlet, a liquid soap dispenser (26, 28, 58) arranged to dispense soap onto a user's hands after water has been dispensed through the water outlet for a predetermined period during a wash cycle and an electronic monitoring system to record each hand wash, characterised in that the water outlet (56) is positioned adjacent a soap outlet (58) and an infrared proximity sensor (60) on an underside of a part (52) of a housing (50) which projects forwardly above a hand wash basin and which contains the liquid soap dispenser, whereby when hands are positioned below the water outlet the infrared proximity sensor causes the water supply to be switched on, whereupon soap is dispensed through the soap outlet onto the user's hands after said predetermined period, and in that the monitoring system is arranged to record a wash only if, after the user's hands have been inserted below the water outlet, the hands are kept below the water outlet and soap dispenser until soap has been dispensed.
2. A hand washing and rinsing unit according to claim 1 wherein the supply of water and soap is controlled by timing relays triggered by a proximity sensor (60) so that water flows for a predetermined initial period, after which soap is dispensed for a predetermined period and thereafter water continues to flow for a further predetermined period or until hands are withdrawn from below the water outlet (56).
3. A hand washing and rinsing unit according to any preceding claim wherein the soap is supplied by means of a dosing pump (26).
4. A hand washing and rinsing unit according to any preceding claim further comprising an integral hand wash basin.
5. A hand washing and rinsing unit according to any preceding claim wherein the monitoring system includes a digital display (62) to indicate the number of times the soap has been dispensed.
6. A hand washing and rinsing unit according to any preceding claim wherein the electronic monitoring

10

15

20

25

30

35

40

45

50

55

system includes a central computer arranged to record the name of each individual using the unit, electronic input means (34) being provided to enable the user to enter a user code.

### Patentansprüche

1. Ein Handwasch- und -spülgerät für ein Waschbecken, umfassend eine Wasserzufuhr (53), einen Wasserauslass (56) mit einer Wasserzufuhr (53, 54) daran, Mittel (20, 32, 60) zum automatischen Einschalten der Wasserzufuhr, wenn Hände unter den Wasserauslass geführt werden, einen Spender für flüssige Seife (26, 28, 58), der so angeordnet ist, dass er nach Abgabe von Wasser durch den Wasserauslass über eine vorbestimmte Zeitspanne während eines Waschzyklus Seife auf die Hände eines Benutzers abgibt, und ein elektronisches Überwachungssystem, das jede Handwäsche registriert, dadurch gekennzeichnet, dass der Wasserauslass (56) neben einem Seifenauslass (58) und einem Infrarot-Näherungssensor (60) auf einer Unterseite eines Teils (52) eines Gehäuses (50) positioniert ist, das oberhalb eines Handwaschbeckens nach vorne vorsteht und das den Spender für flüssige Seife beinhaltet, so dass, wenn Hände unterhalb des Wasserauslasses positioniert werden, der Infrarot-Näherungssensor das Einschalten der Wasserzufuhr veranlasst, woraufhin Seife durch den Seifenauslass auf die Hände des Benutzers nach der genannten vorbestimmten Zeitspanne abgegeben wird, und dadurch, dass das Überwachungssystem so angeordnet ist, dass es nur dann eine Wäsche registriert, wenn, nachdem die Hände des Benutzers unter den Wasserauslass geführt wurden, die Hände unter dem Wasserauslass und dem Seifenspender gehalten werden, bis Seife abgegeben wird.
2. Ein Handwasch- und -spülgerät nach Anspruch 1, bei dem die Wasser- und Seifenzufuhr durch von einem Näherungssensor (60) ausgelöste Zeitsteuerrelais so gesteuert wird, daß während einer vorbestimmten anfänglichen Zeitspanne Wasser fließt, wonach während einer vorbestimmten Zeitspanne Seife abgegeben wird und worauf Wasser während einer weiteren vorbestimmten Zeitspanne oder bis die Hände von unterhalb des Wasserauslasses (56) entfernt werden, weiterfließt.
3. Ein Handwasch- und -spülgerät nach einem der vorstehenden Ansprüche, bei dem die Seife mit Hilfe einer Dosierpumpe (26) geliefert wird.
4. Ein Handwasch- und -spülgerät nach einem der vorstehenden Ansprüche, das des weiteren ein integrales Handwaschbecken umfaßt.

5. Ein Handwasch- und -spülgerät nach einem der vorstehenden Ansprüche, bei dem das Überwachungssystem zwecks Anzeige der Anzahl von Seifenabgaben eine Digitalanzeigevorrichtung (62) umfaßt.
6. Ein Handwasch- und -spülgerät nach einem der vorstehenden Ansprüche, bei dem das elektronische Überwachungssystem einen zentralen Computer umfaßt, der so angeordnet ist, daß er den Namen jeder das Gerät benutzenden Person registriert, wobei ein elektronisches Eingabemittel (34) vorgesehen ist, das den Benutzer zur Eingabe eines Benutzercodes befähigt.

### Revendications

1. Système de lavage et de rinçage des mains pour lavabo comprenant une alimentation en eau (53), un orifice de sortie d'eau (56) avec une alimentation en eau (53, 54) dudit orifice, un moyen (20, 32, 60) pour actionner automatiquement l'alimentation en eau quand les mains sont introduites sous l'orifice de sortie d'eau, un distributeur de savon liquide (26, 28, 58) agencé pour distribuer du savon sur les mains d'un utilisateur après que l'eau a été fournie par l'orifice de sortie d'eau pendant une durée prédéterminée pendant un cycle de lavage, et un système de contrôle électronique pour enregistrer chaque lavage des mains, caractérisé en ce que l'orifice de sortie d'eau (56) est positionné à proximité d'un orifice de sortie de savon (58) et d'un capteur de proximité à infrarouge (60) sur le dessous d'une partie (52) d'un logement (50) qui dépasse vers l'avant au-dessus d'un lavabo et qui contient le distributeur de savon liquide, de telle sorte que lorsque les mains sont positionnées sous l'orifice de sortie d'eau, le capteur de proximité à infrarouge fait actionner l'alimentation en eau, sur quoi le savon est distribué par l'orifice de sortie de savon sur les mains de l'utilisateur après ladite durée prédéterminée, et en ce que le système de contrôle est agencé pour enregistrer un lavage seulement si, après que les mains de l'utilisateur ont été introduites sous l'orifice de sortie d'eau, les mains de l'utilisateur sont tenues en dessous de l'orifice de sortie d'eau et du distributeur de savon jusqu'à ce que le savon ait été distribué.
2. Système de lavage et de rinçage des mains selon la revendication 1 dans lequel l'alimentation en eau et en savon est commandée par des relais de temporisation déclenchés par un détecteur de proximité (60) de telle sorte que l'eau coule pendant une période initiale prédéterminée, après quoi le savon est distribué pendant une période prédéterminée, puis l'eau continue de couler pendant une nouvelle
- période prédéterminée ou jusqu'à ce que les mains soient retirées du dessous de l'orifice de sortie d'eau (56).
3. Système de lavage et de rinçage des mains selon l'une quelconque des revendications précédentes dans lequel le savon est fourni au moyen d'une pompe de dosage (26).
4. Système de lavage et de rinçage des mains selon l'une quelconque des revendications précédentes, comprenant en outre un lavabo intégré.
5. Système de lavage et de rinçage des mains selon l'une quelconque des revendications précédentes dans lequel le système de contrôle comprend un affichage numérique (62) pour indiquer le nombre de fois que le savon a été distribué.
6. Système de lavage et de rinçage des mains selon l'une quelconque des revendications précédentes dans lequel le système de contrôle électronique comprend un ordinateur central agencé pour enregistrer le nom de chaque utilisateur du système, un moyen d'entrée électronique (34) étant prévu pour permettre à l'utilisateur d'entrer un code d'utilisateur.

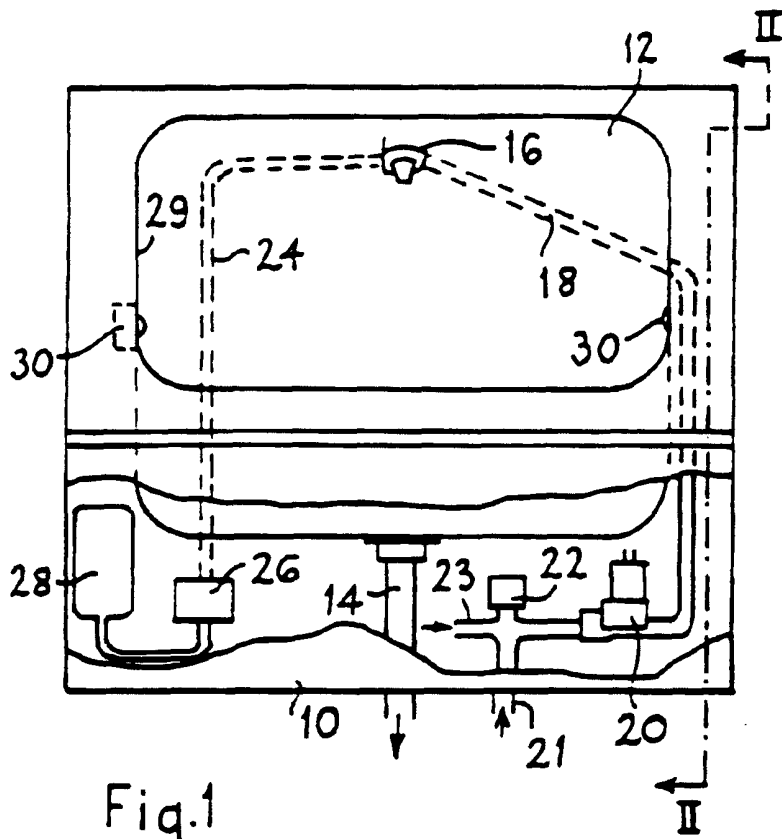

Fig. 1

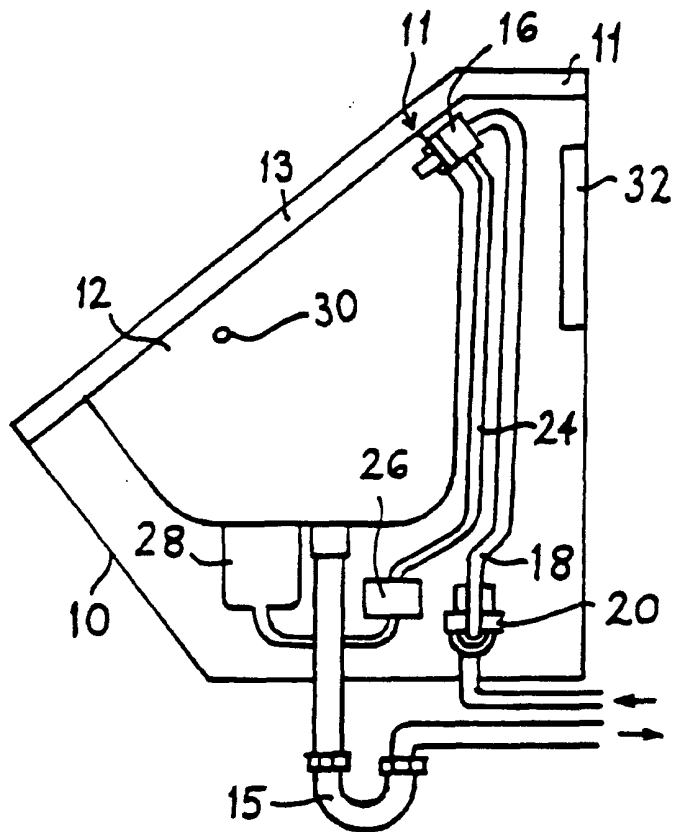

Fig. 2

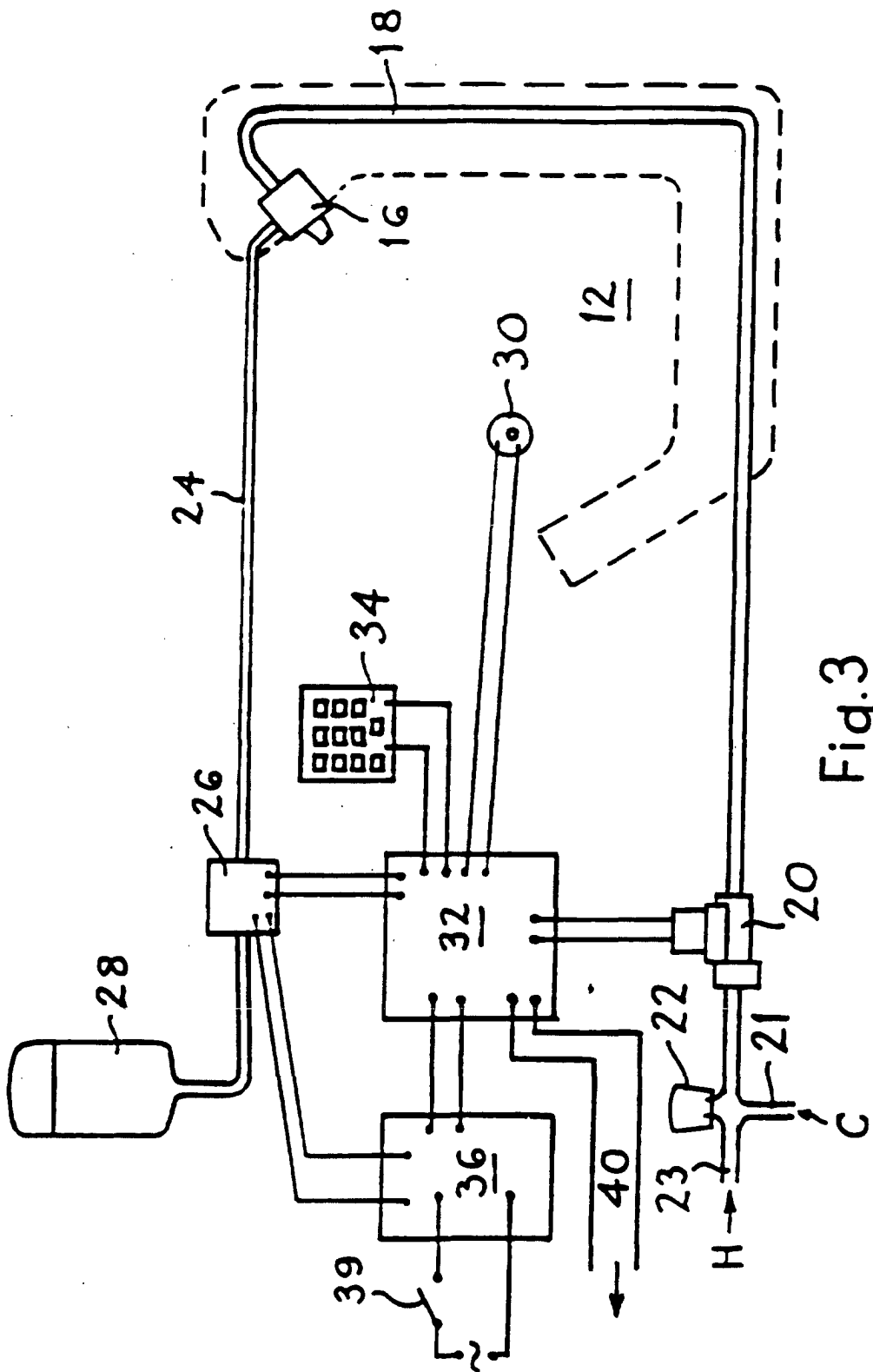

Fig.3

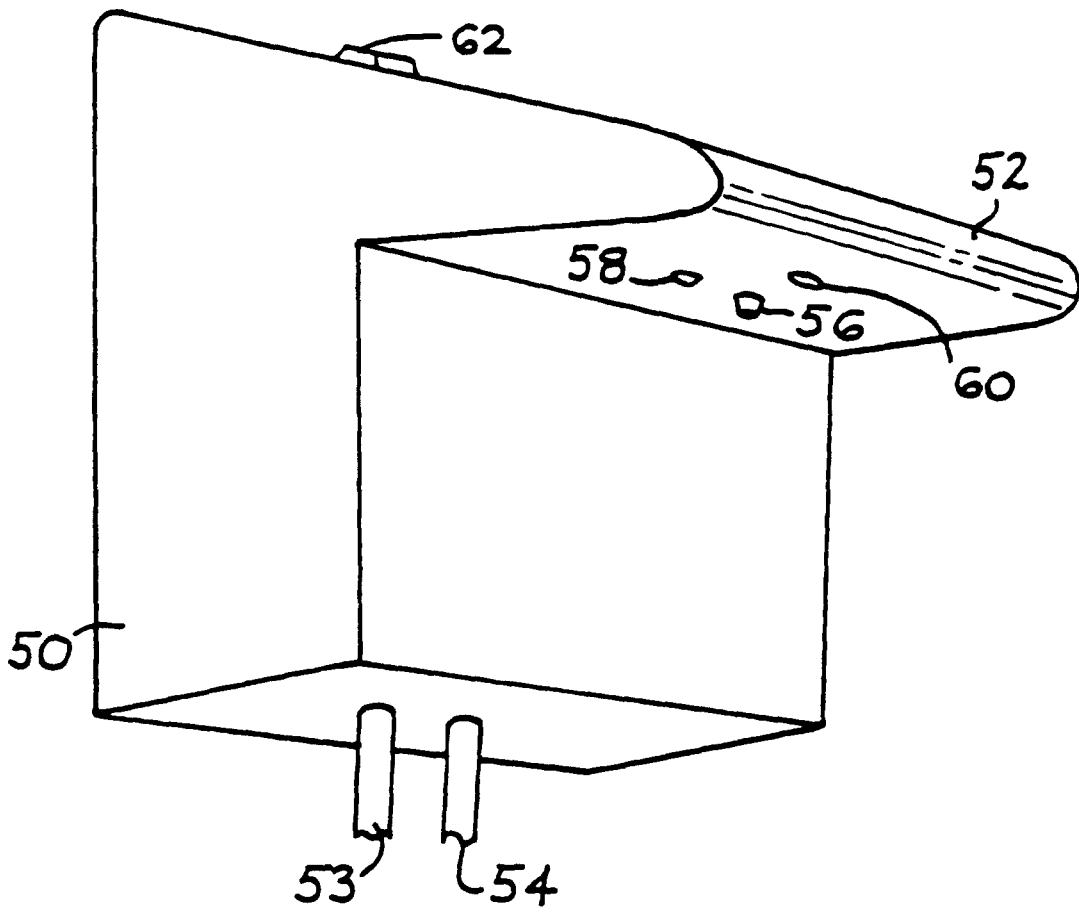

Fig.4