

Oct. 26, 1937.

S. L. MATOUSEK

2,096,972

TYING MACHINE

Filed Sept. 3, 1935

6 Sheets-Sheet 2

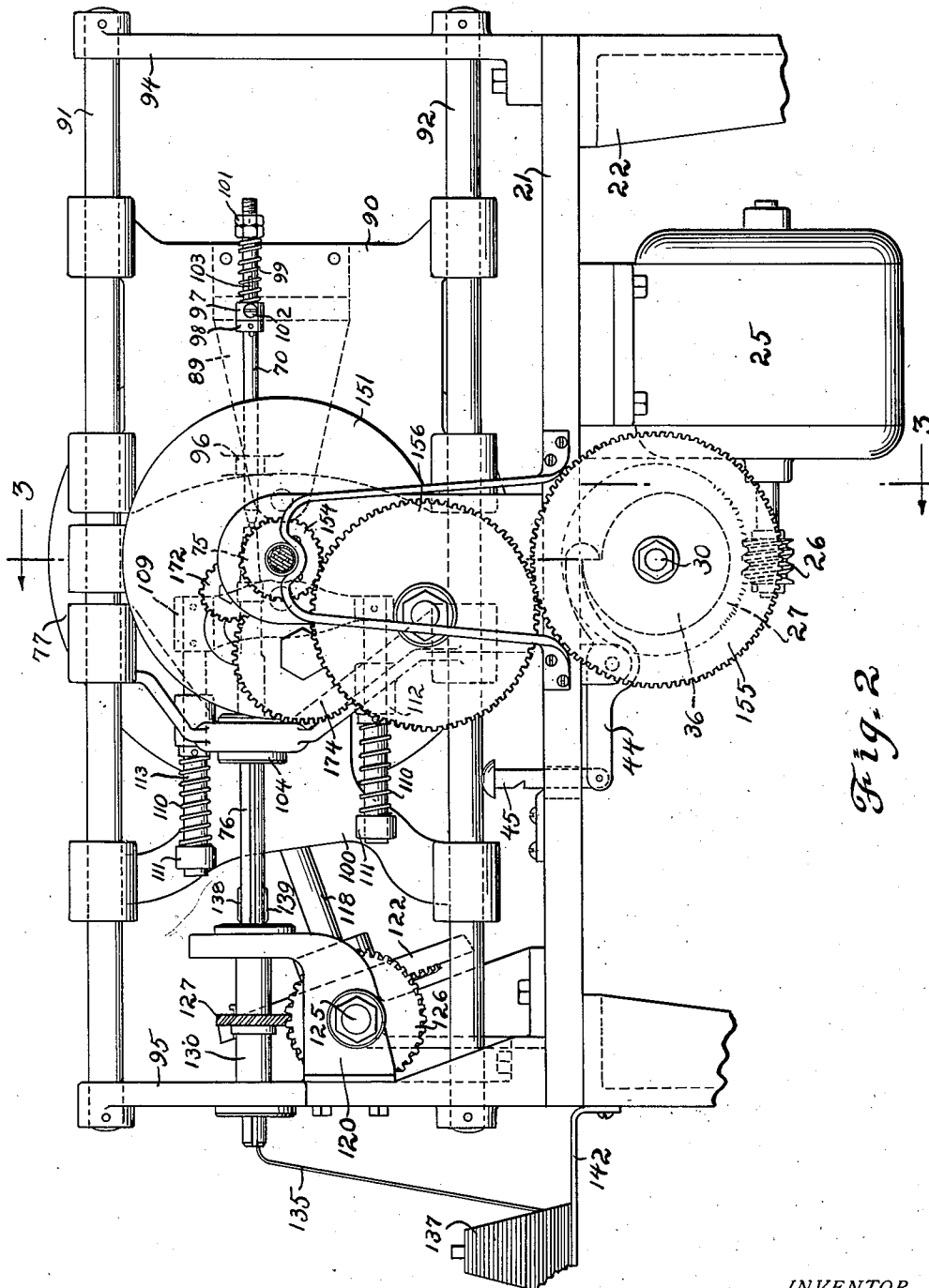

Fig. 2

INVENTOR
BY *Stephen L. Matousek*
Bruce J. Hardy
ATTORNEYS.

Oct. 26, 1937.

S. L. MATOUSEK

2,096,972

TYING MACHINE

Filed Sept. 3, 1935

6 Sheets-Sheet 3

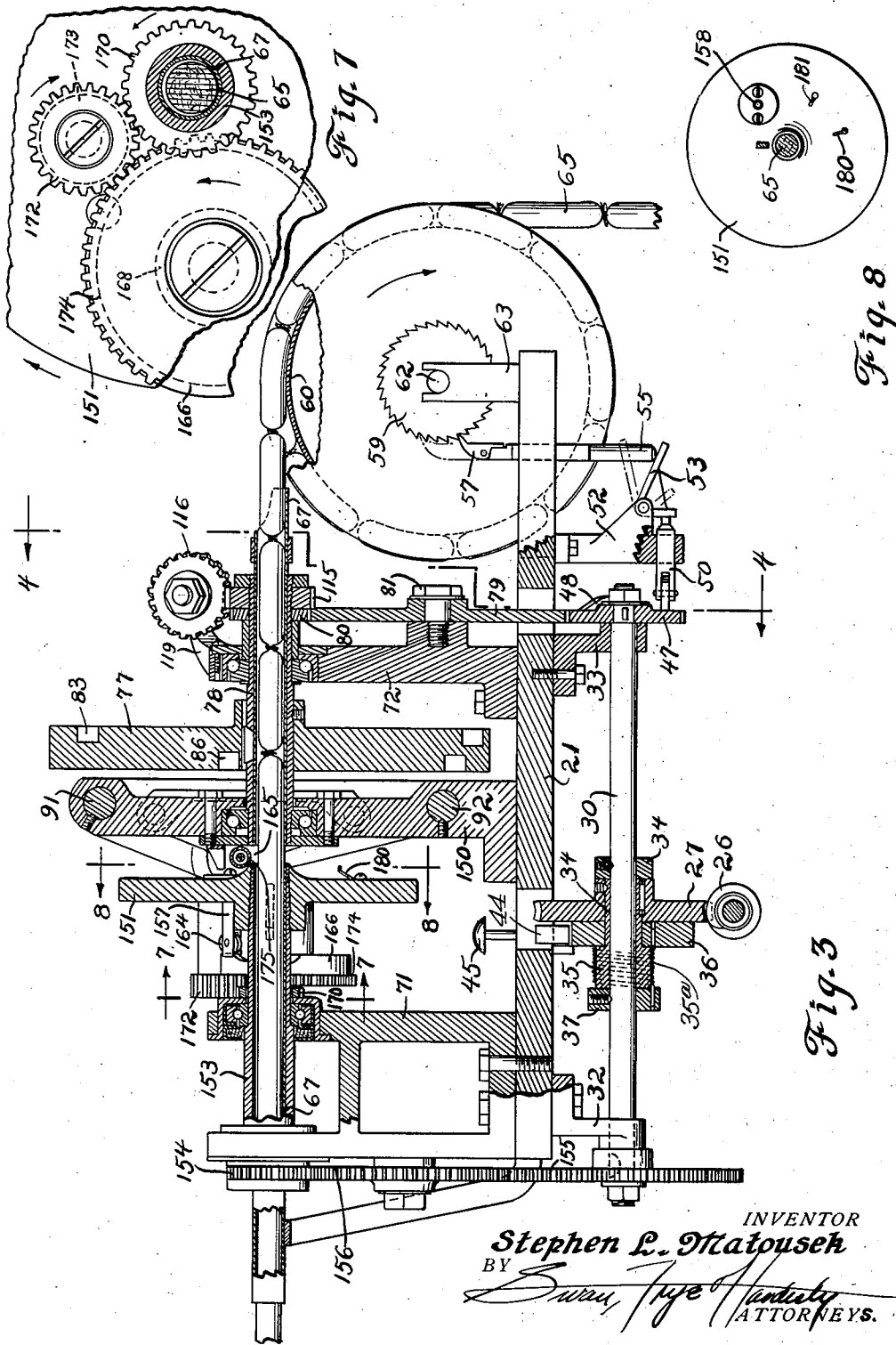

Oct. 26, 1937.

S. L. MATOUSEK

2,096,972

TYING MACHINE

Filed Sept. 3, 1935

6 Sheets—Sheet 4

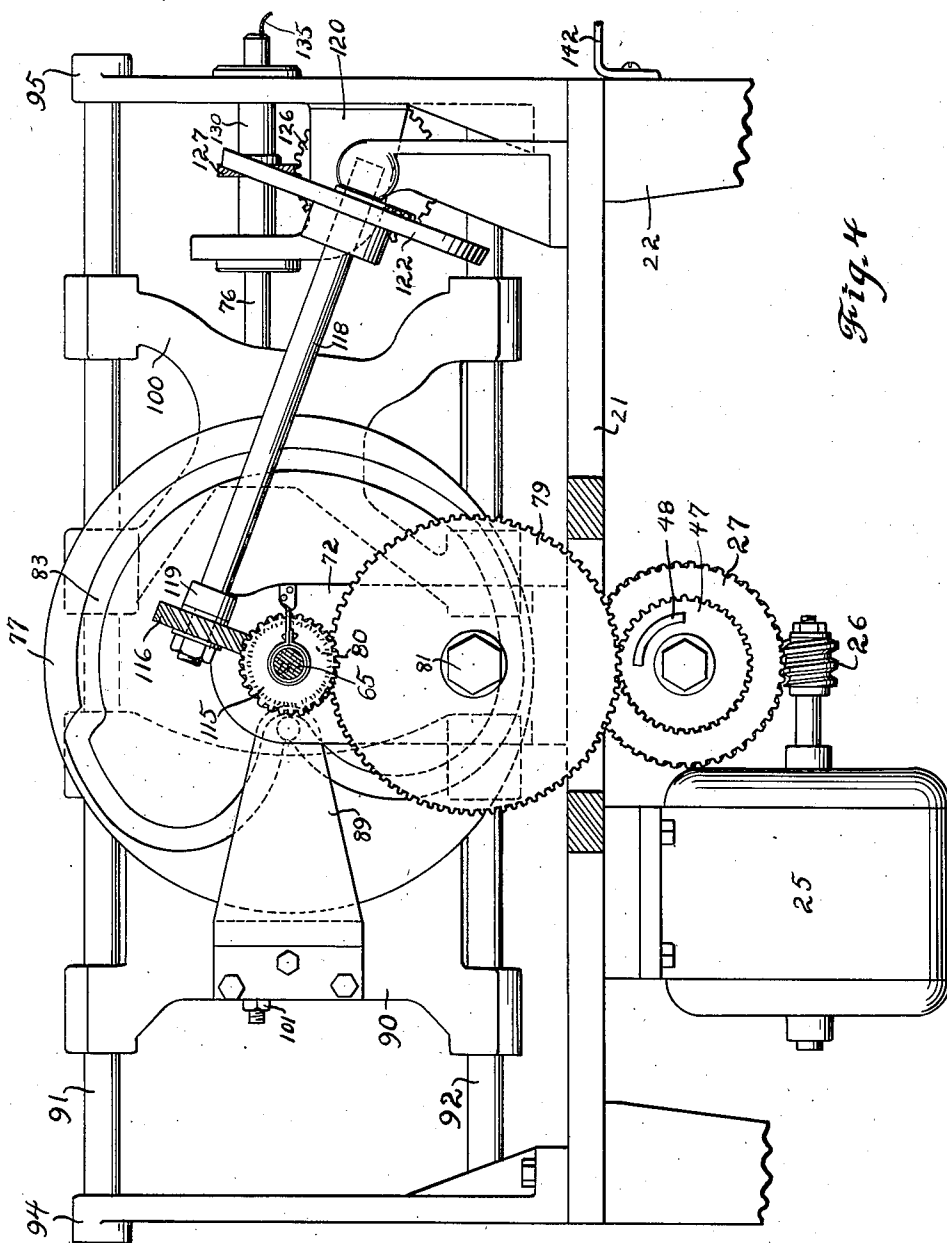

INVENTOR
Stephen P. Matousek
BY *Paul J. Hackett*
ATTORNEYS.

Oct. 26, 1937.

S. L. MATOUSEK

2,096,972

TYING MACHINE

Filed Sept. 3, 1935

6 Sheets-Sheet 5

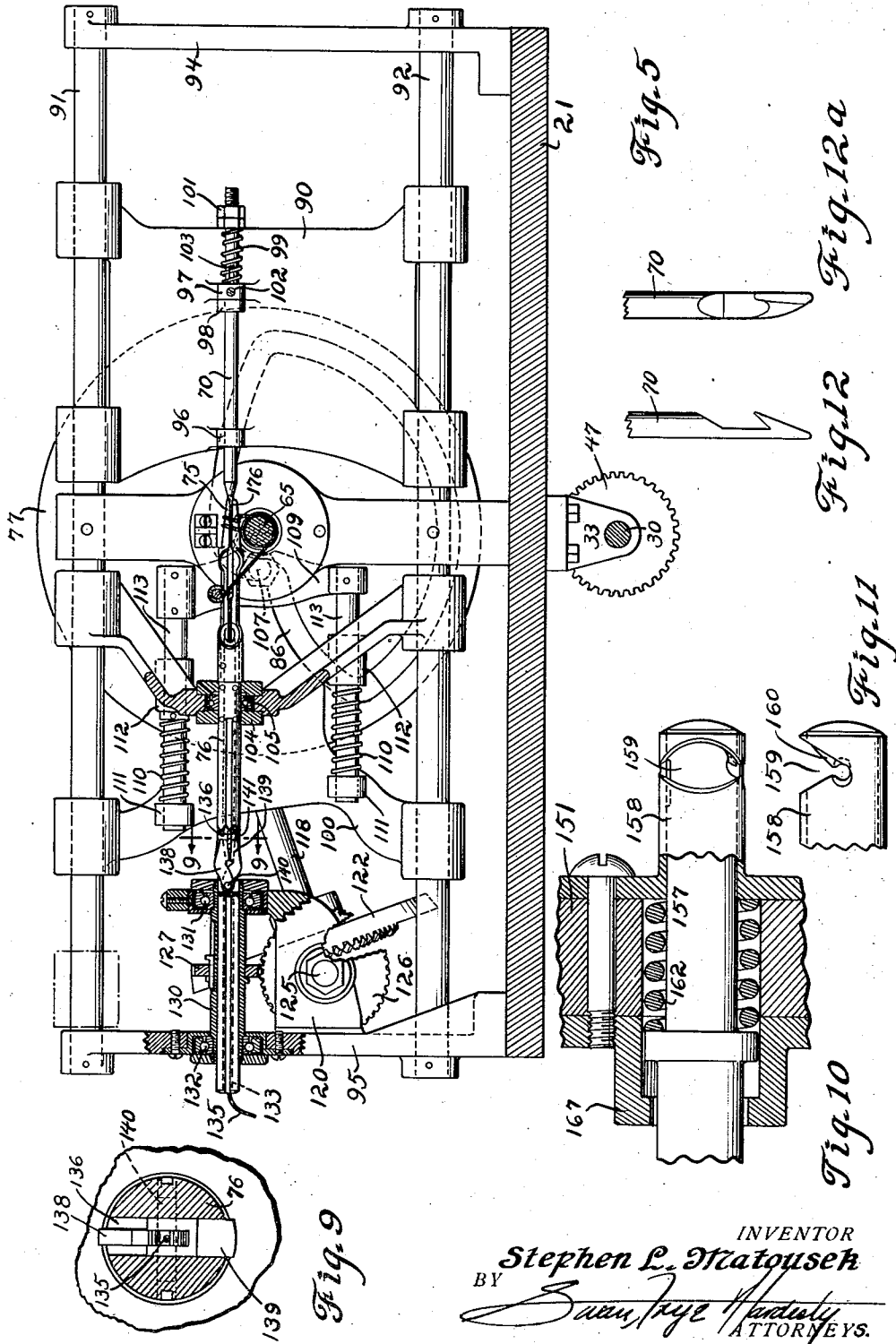

INVENTOR
Stephen L. Matousek
 BY *Swan, Faye & Matousek*
 ATTORNEYS.

Oct. 26, 1937.

S. L. MATOUSEK

2,096,972

TYING MACHINE

Filed Sept. 3, 1935

6 Sheets-Sheet 6

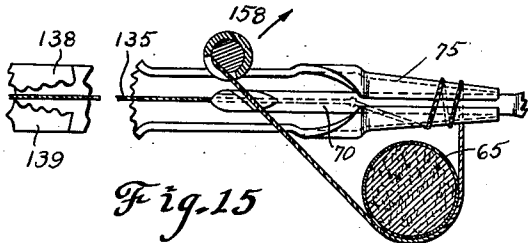

Fig. 15

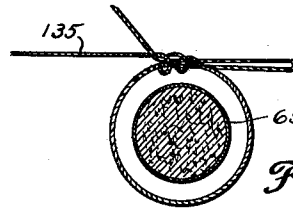

Fig. 18

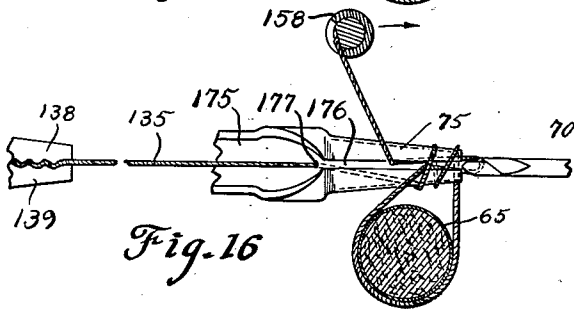

Fig. 16

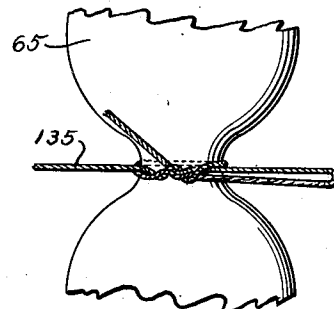

Fig. 19

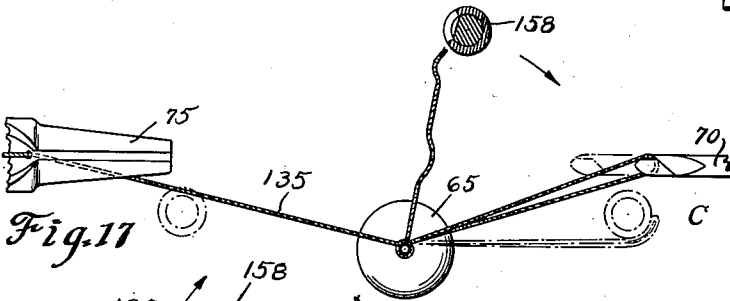

Fig. 17

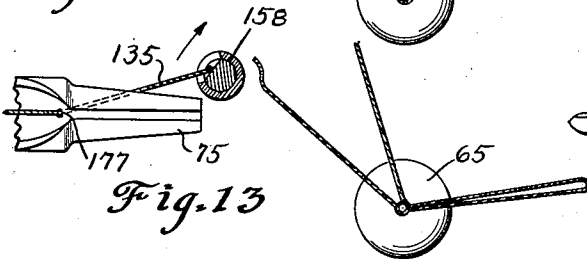

Fig. 13

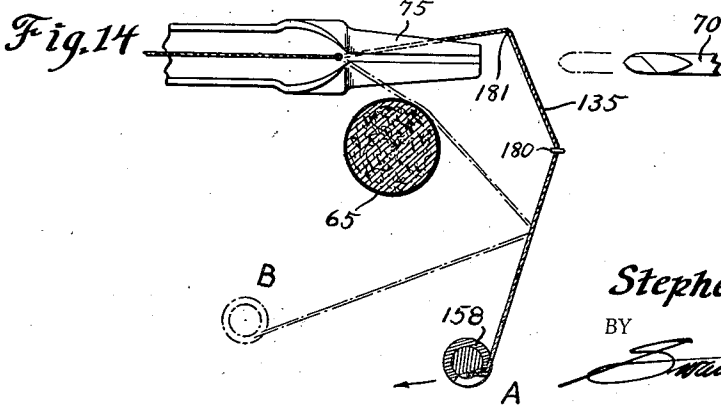

Fig. 14

INVENTOR.
Stephen L. Matousek
BY
Erwin J. Hendrick
ATTORNEYS.

UNITED STATES PATENT OFFICE

2,096,972

TYING MACHINE

Stephen L. Matousek, Dearborn, Mich.

Application September 3, 1935, Serial No. 38,945

20 Claims. (Cl. 17—34)

This invention relates to automatic machines for tying cord or other relatively limp binding materials about any desired work, although particular utility is to be found in the tying of compressible substances such as sausages, bologna and other food products encased in readily deformable covers. An important object of the invention is to provide an improved tying machine capable of quickly tying and pulling taut upon desired work a modified bow or slip knot which, when completed, effects a very secure tie yet may be quickly and easily released.

Another important object is the provision of improved tying apparatus which is of particular utility in repeatedly tying a plurality of such knots in succession, as in automatically tying into link form an elongated sausage casing fed into the machine, and whereby compressible material such as encased sausage may, by the automatic tightening of the knot, be constricted to form the usual divisions between the links of sausage and the like.

Other objects and advantages will be apparent from the following description wherein reference is made to the accompanying drawings illustrating a preferred embodiment of my invention and wherein similar reference numerals designate similar parts throughout the several views.

In the drawings:

Figure 1 is a plan view of a machine incorporating the principles of this invention, certain parts being omitted.

Figure 2 is an end elevation, partly in section, taken substantially on the line 2—2 of Figure 1, and looking in the direction of the arrows.

Figure 3 is a vertical sectional elevation taken substantially on the line 3—3 of Figure 2 and looking in the direction of the arrows.

Figure 4 is a vertical cross-section taken substantially on the line 4—4 of Figure 3 and looking in the direction of the arrows.

Figure 5 is a vertical sectional elevation taken substantially on the line 5—5 of Figure 1 and looking in the direction of the arrows.

Figure 6 is a detailed section taken substantially on the line 6—6 of Figure 1 and looking in the direction of the arrows;

Figures 7 and 8 are detailed sections taken substantially on the lines 7—7 and 8—8 of Figure 3 respectively, and upon different scales looking in the directions of their respective arrows;

Figure 9 is a detailed cross-section taken substantially on the line 9—9 of Figure 5 and looking in the direction of the arrows.

Figure 10 is an enlarged detailed view partly in

longitudinal section and partly in side elevation, of a part of the cord-holding, cutting and wrapping mechanism.

Figure 11 is a fragmentary side view of the head of the holding and cutting means.

Figures 12 and 12a are side and front elevational views respectively of the working end of the needle.

Figures 13 to 17 inclusive are diagrammatic views successively showing positions assumed by the tying elements and the cord in positions they occupy during the tying of a knot, indicating the manner in which the tie is effected; and

Figures 18 and 19 are sectional and elevational views respectively of the tied knot, before and after it is pulled taut.

Referring now to the drawings, reference character 21 designates the bed of my improved machine, shown as comprising a relatively heavy horizontal plate carried on legs 22. Suspended beneath the bed is a driving motor 25, which, through worm 26 and worm wheel 27, drives the countershaft 30, hung beneath the frame in bearing brackets 32—33 (Fig. 3). Worm wheel 27 is secured to the sleeve 34, which is integral with the clutch drum 35. The unit comprising the sleeve 34 of the drum 35 is mounted for free rotation on the shaft 30. A notched disc 36 is freely journaled on the sleeve 34 between the gear and drum, while a helical torsion spring 35a encircles the drum and is fastened at one end to the disc and at the other end to a collar 37 secured to the shaft. The spring may be somewhat biased to contract, and arranged so that the frictional drag of the drum upon the spring tends to expand the spring when the disc is held. When the notched disc is released, as by depressing the foot pedal 45, the biasing of the spring and/or the inertia of the disc tend to wrap the spring about the drum, the engagement of the spring and drum being tightened by cumulative increase of friction between the spring and the drum as the latter picks up the drive and turns the shaft through the spring and collar. When rotation of the disc is halted, the turning moment at the collar end of the spring expands it to free the drum and interrupt the drive, again allowing free rotation of the gear and drum. If, as shown, a single notch is provided in disk 36, (see Fig. 2) the operating parts will always stop in the same position, and the gearing, cams and mechanism are preferably so proportioned that one complete tying operation and advancement of the work to the extent of one link take place during one revolution of the countershaft, which

may thus be stopped and started by the operator to perform one or any number of complete tying operations, although an operation which has been started is always completed.

5 Fast upon one end of shaft 30 is a gear 47, the web of which also serves as a face cam, carrying upon its outer surface a lobe 48 which when the gear is rotated intermittently reciprocates the follower 50. The follower, slidable in a bracket 10 52 also hung from the under side of the frame, engages a bellcrank 53 which abuts the bottom of and transmits the intermittent motion to a rod 55 vertically slidable in the bed and carrying at its upper extremity a pawl 57 engageable with 15 the teeth of a ratchet wheel 59. The ratchet wheel is rotatable with and serves to actuate the work drum 60, carried therewith on a shaft 62 trunnioned in bearing supports 63, which bearings may be uncapped and the drum held in place 20 only by gravity, in order to enable its easy removal. It will be seen that by virtue of this arrangement the drum may be intermittently rotated in a clockwise direction, as viewed in Figure 3. The drum serves to intermittently actuate the 25 continuous sausage casing 65 shown as comprising the work, along which at spaced points the machine ties tightly constricting binding material defining the links of the sausage, the rest periods being coordinated with the tying mechanism 30 presently to be described and the tying of course being effected during such periods of rest, while the degree of each intermittent rotation of the drum determines the lengths of the individual sausages. The rope or chain of sausage may 35 simply be wrapped once or twice about the drum to enable the latter to exert tractive effort thereupon, and thereafter may debouch into a receptacle (unshown) or to any other destination. The tractive effort of the drum pulls the sausage chain 40 through a tube 67 carried above the bed of the machine in the main brackets 71—72.

The tying mechanism includes a reciprocating needle 70, and a shuttle 75 whose tapered nose portion is both rotatable and reciprocable into 45 and out of interfitted engagement with the needle. Sliding movements of the needle and shuttle are effected and controlled by a plate cam 77 mounted between the brackets 150—72 to rotate on an axis concentric with the work tube 67, on the 50 tubular shaft 78 encircling the work tube and driven from countershaft 30 by gear 47, meshing with an idler 79 which in turn drives the tubular cam shaft through gear 80 mounted thereon outside the bracket 72. Idler gear 79 is rotatable 55 upon a stub shaft formed by a shouldered cap screw 81 carried by the bracket.

Grooved tracks 83—86 are formed in opposite faces of the plate cam 77, the former engaged by a follower 87 carried by an arm 89 extending be- 60 hind the cam and connected to a slide 90 reciprocable across the opposite face thereof toward and from the work, which is exposed by a break 165 in the work tube, the slide element being carried upon slide bars 91—92 extending transverse- 65 ly of the work tube axis above and below the same, and supported from the bed by brackets 94—95. Slide 90 carries the needle 70, which is reciprocable relatively to the slide in brackets 96—97 shown as cast integrally with the slide, movement 70 of the needle therethrough in one direction being limited by the stop 98, while spring 99 allows yieldable movement of the needle with respect to the slide in the opposite direction. The resistance of the spring is adjustable by means of 75 lock nuts 101 threaded on the end of the needle

and the spring is trapped between the lock nuts and bracket 97. A guide screw 102 carried by bracket 97 may also slidably extend into a slot 103 formed in the needle, to hold the latter 5 against turning. The nature and extent of the sliding movement of the needle will be explained later in conjunction with the description of the machine.

A somewhat similar slide 100 also carried by the slide bars 91—92 upon the opposite side of 10 the work tube and likewise reciprocable toward and away from the work, carries the shuttle 75 which is formed integrally with a shuttle tube 76, forming a continuation of the shuttle, both being hollow, and the shuttle and tube being mounted 15 for rotation in, but held against longitudinal movement with respect to the slide 100, the tube 76 being secured in and extending through a collar 104 journaled in the slide 100 as in anti-friction bearing 105. The follower 107 by which 20 slide 100 is reciprocated engages track 86. Such follower is not directly carried by the slide, but by a yoke 109, through which it may impart a yieldable drive to the slide, to which it is connected through springs 110 mounted between col- 25 lars 111 fixed to rods 113, and brackets 112 carried by the slide member 100. The rods 113 are slidable in the brackets and secured to the yoke 109 so that a yieldable drive from the latter may 30 be transmitted through the springs. Further constructional details of the shuttle, and the purpose and extent of its movement, will be set forth in detail later in connection with the explanation of the operation of these parts.

Rotation of the shuttle is effected through 35 gears 115—116, the former mounted on and drivable with the cam shaft 78, and the latter carried by an inclined shaft 118 extending therefrom to a point adjacent the end of the shuttle tube remote from the work tube, and supported 40 in supplementary brackets 119—112 carried by the bracket 72 and bed 21 respectively. The shaft 118 carries at its lower end a mutilated bevel gear 122 through which intermittent drive is imparted to the bevel gear 123 carried upon 45 stub shaft 125 which transmits the drive to helical gears 126, 127, the latter keyed upon a hollow shaft 130 rotatably mounted in anti-fric- 50 tion bearings 131, 132 carried by bracket 95 and in extension 120 thereof. The shuttle tube 76 is slidably keyed in and extends through the hollow shaft 130. The central bore in the shuttle tube is designated 133, and allows passage of the tying cord 135 therethrough, which is supplied 55 of a cop 137 mounted beneath the open end of the tube on a bracket 142 projecting from the frame. Carried by the shuttle tube and movable into and out of the hollow shaft 130 by sliding movement of the former, is a gripping device 138, 139 carried in a cut out portion 136 60 of the shuttle tube. The gripping device is formed of hinged jaw sections 138, 139 which as the shuttle is retracted from the work by rearward movement of the shuttle tube grip the cord to cause continued retracting movement to exert a pull thereupon. The jaws are pivotally 65 mounted in the transverse slot 136 extending through the tube 76, which slot intersects the central bore 133, as upon a cross pin 140. The jaws are tapered at their ends facing the tubular shaft 130, and so proportioned that when slid 70 into the hollow shaft by rearward movement of the shuttle tube, they are thereby forced together so closely as to tightly grip the cord 135, where-

as at other times, the jaws not being forced together, the cord is freely slidable between them.

The cord passes through the shuttle tube to and out of the shuttle, for engagement with additional cord handling means. Such means are carried partly by a fixed standard 150 mounted upon the bed between brackets 71—72 and assisting in the support of the rods 91—92, and partly by a plate 151 rotatable concentrically about the work tube upon the other side of the standard 150 from cam 77 and arranged upon a hollow shaft 153 rotatable in and extending through bracket 71 and drivable by gear 154 mounted on the shaft on the opposite side of the bracket, the gear being drivable from countershaft 30 by countershaft gear 155 and idler 156.

Plate 151 carries a cord gripping and cutting device including a plunger 157 slidable there-through and extending into a slotted head 158 projecting from the plate upon its side facing the standard 150. The slot 159 in the head is tapered, as best shown in Figures 10 and 11, and at one side of one end a sharpened projection 160 adapted to serve as a cutter is provided. The bottom of the slot terminates in a partly cylindrical transverse opening, while the plunger 157 is provided with conformingly shaped slotted openings, whereby when the plunger is reciprocated in the head, one end of a cord extending through the slot is cut off, while the other end is gripped between the plunger and head. The cutter head assembly of course travels in a planetary orbit when the plate is rotated. Such orbit lies approximately in the plane of the break 165 in the work tube which exposes a short length of the sausage casing or other work, between a standard 150 and plate 151. The plunger 157 is urged toward retracted position by a spring 162 acting upon the plunger within a housing provided by an enlarged opening in the plate and by a continuation thereof formed by a bracket 167 carried by the rear face of the plate, through which the plunger 157 extends, carrying upon its rear extremity a follower roller 164 actuable by a face cam 166. The cam 166 is carried by the plate 151, being mounted for planetary rotation and to revolve about its own axis upon a post 168 eccentrically carried by the plate in such position that follower 164 lies upon the circular track of the cam. Rotation of the cam about its own axis is effected by a fixed gear 170 secured to bracket 71 concentrically surrounding the work tube and shaft 153, upon which gear rolls an idler 172 meshing therewith and with the gear 174 mounted to turn as a unit with and drive the cam 166 and carried by the plate 151 upon another post 173.

The side of the shuttle facing the plate 151 is cut away as at 175, and its tapered nose is slotted as at 176 to provide connection between its end and the cut out portion 175. It will also be seen upon inspection of Figure 1 that when the shuttle is in its inwardly projected position, the orbit of the head 158 carries it through the cut out portion of the shuttle, in which cut out portion the cord extending through the shuttle is exposed. In threading the machine the cord is carried through the cut out portion of the shuttle and out the rear wall thereof through an opening 177, and its end is placed in and gripped by the head 158, which maintains its hold upon the end of the cord during a greater part of a single orbital revolution of the head.

At the commencement of the cycle of operations involved in the tying and tightening of a

knot, the operating parts occupy the positions shown in Figure 13, the shuttle 75 and needle 70 being retracted with respect to the work 65. The rotation of plate 151 carries the head 158 in a clockwise direction as the parts are considered in diagrammatic Figures 13 to 17 inclusive. The shuttle together with its tube moves forward with the rotation of member 158 until the shuttle reaches a position shown in Figure 14, where it dwells for a certain interval. The gripping device 138—139 being freed by the advancement of the shuttle tube, continued rotation of the head 158 pulls the cord from the shuttle, and it is caught by and wrapped about the spring fingers 180, 181 mounted on the plate 151, and spaced outwardly from the work. The tension upon the cord subsequently pulls it off the hooks and it is drawn in against the work as the gripping head approaches the position shown in Figure 15. As the head travels from the positions indicated successively at A and B in Figure 14 to the position indicated in Figure 15, the shuttle is rotated to wrap the cord about the end (by the toothed portion of mutilated gear 122). The needle then enters the shuttle. Its hooked end engages beneath the portion of the cord stretched between head 158 and the work, and the needle is then retracted, as indicated in Figure 16, forming a simple bight which it pulls through the loop constituted by the portion of the cord wrapped about the nose of the shuttle, the cord portions extending to the head 158 and to the work traveling through the slot 176 and pulling free of the shuttle with the loops, as the shuttle is retracted, in the manner indicated in Figure 17. The retraction of the shuttle closes the gripping device 138, so that continued retraction pulls upon the end of the cord running through the shuttle to the supply, to tighten the noose, while the continued retraction of the needle pulls upon the bight which extends through the loops, tightening the part drawn about and constricting the sausage.

It will be seen that the bight is freed of the shuttle, except for the portion running through opening 177, to the supply, by the retraction of the shuttle and by the holding effect of the cord portions which extend from the slot 176. During the entire period thus far described cam 166 has held plunger 157 in projected position, the head 158 having traveled more than 360 degrees, but at this phase, after the knot has been tightened sufficiently, cam 166 allows plunger 157 to recede under the influence of spring 162, freeing the end of the cord. Thereafter, as indicated at C in dotted lines in Figure 17 the head 158, continuing its travel, strikes the loop held by the needle, disengaging the cord therefrom, thereafter traveling freely until it engages the portion of the cord stretched between the shuttle opening 177 and the work, which it catches in the slot 159. Cam 166 then projects plunger 157, severing the end of the cord connected to the work and gripping the end extending from the shuttle, which end it thus picks up to carry around the work in the commencement of another cycle, which repeats in the same fashion, the parts at this time having reassumed their Figure 13 positions and the phases recurring as described. The cam in order to effect desired operation of plunger 157 makes one revolution in two complete turns of the disc 151 and head 158, and the other parts are of course proportioned and timed to impart in their indicated and proper sequence the movements

described in conjunction with the foregoing description of the operation of the machine.

While it will be apparent that the illustrated embodiment of my invention herein disclosed is well calculated to adequately fulfill the objects and advantages primarily stated, it is to be understood that the invention is susceptible to variation, modification and change within the spirit and scope of the subjoined claims.

10 What I claim is:

1. Binding apparatus including a work conducting tube, having an opening therein, means for intermittently feeding work through the tube and through said opening, wrapping means comprising a combined holding and cutting head for binding material rotatable about said opening in the work tube, a shuttle element laterally reciprocable toward and from a position offset from but adjacent the opening in the work tube, a needle element oppositely reciprocable toward and from said position and into and out of interfitted engagement with the shuttle element, said head being rotatable in a path intersecting the path of reciprocating travel of the needle and shuttle elements, means for reciprocating and rotating the shuttle element, means for reciprocating the needle element, means for feeding binding material to one of said elements, catching means carried by the other element for engaging and pulling the binding material off the one to which it is fed, means for rotating the shuttle element to wrap the binding material about it, and means for rotating the head to wrap the binding material about the work before such reception and rotation of the needle and shuttle elements, a portion of the binding material so carried about the work by the head being engageable by the needle element and adapted to be drawn thereby through the shuttle element and the portion of the binding material wrapped about the shuttle element by rotation of the latter, whereby when the binding material is released from said shuttle and needle elements an interwoven tied loop is provided by the interengagement of said portions of the binding material.

2. Apparatus as set forth in claim 1 including means for turning said head through two revolutions for each reciprocation of the shuttle and needle elements into and out of interfitted engagement, and for actuating the head to pick up and sever a portion of the binding material upon one revolution and drop the end picked up and held at the completion of such revolution, and for releasing the binding material from the needle and shuttle elements during the subsequent revolution of the head after the held end has been dropped.

3. Apparatus as set forth in claim 1 in which the shuttle has a tapered and slotted nose portion and a cut out portion behind the nose, through which cut out portion the head is rotatable, and in which the portion of the binding material wrapped about the work by the head is carried thereby laterally through said cut out portion of the shuttle, the needle being hooked and projectable through the nose of the shuttle into engagement with said portion of the binding material lying transversely of the cut out portion after rotation of the shuttle has wrapped another portion of the binding material about the nose of the shuttle, the reciprocating means for the needle being arranged to thereafter withdraw the needle to pull the portion engaged by the hook through the loop formed by the portion wrapped about the nose, and the portion extending to the

work and the head being releasable from the shuttle by way of the path provided by the slot in the nose portion.

4. In a device of the character described, interengageable needle and shuttle portions, means for feeding binding material through the shuttle to a point adjacent the interengaging area of the needle and shuttle, means for actuating the needle and shuttle to tie the portion of the binding material carried to such area, including means for reciprocating the shuttle, and gripping means actuatable with the shuttle upon movement thereof in one direction to grip the binding material, whereby by continued movement the portion of the binding material held by the gripping means may be pulled to tighten the tie.

5. In a device of the character described, interengageable needle and shuttle portions, a supply of binding material, means for feeding binding material from the supply to a point adjacent the interengaging area of the needle and shuttle, means including a combined cutting and carrying head for forming the end of the binding material fed to such area into a loop extending about desired work, means for actuating the needle and shuttle to tie the ends of the loop, means for pulling upon the binding material to tighten the tie, the head being arranged to travel transversely through the path of the portion of the binding material which extends to said area and which forms the loop, a holding portion carried by the head for gripping the binding material between the supply and the loop, and cutting means also carried by the head for severing and freeing the portion leading to the loop while the holding portion retains the portion leading from the supply.

6. Apparatus as set forth in claim 5 including means for rotating the head before the other recited operations occur and while the holding portion retains the portion of the binding material leading from the supply, to form the loop.

7. In a device of the character described, interengageable needle and shuttle elements, the shuttle being longitudinally apertured, means rotatably and slidably supporting the shuttle element including a longitudinally apertured shaft and rotatable supporting means therefor in which the shaft is slidable to reciprocate the shuttle element, binding material extending through the apertures in the shaft and shuttle, and gripping means engageable with said binding material movable with the shaft and arranged to clamp the binding material to enable the exertion of a pull thereupon.

8. In a device of the character described, a work feeding tube having an opening exposing work fed therethrough, means for conducting binding material to a position adjacent such opening, means for wrapping the binding material about work exposed at the opening, including a pull head for the binding material rotatable substantially in the plane of the opening, and spring fingers spaced from the opening and rotatable in the same plane with the head, whereby the binding material may be wrapped about such fingers by the head, the fingers being releasable by sufficient inward pressure of the binding material.

9. Apparatus as set forth in claim 8 including needle and shuttle elements operable in substantially the same plane and actuatable to tie the ends of a portion of the binding element looped about the work by the head, and cutting means carried by the head for severing the binding material after completion of the tie.

10. Apparatus as set forth in claim 8 including tying elements operable in substantially the same plane and actuatable to tie the ends of a portion of the binding element looped about the work by the head, cutting means and gripping means carried by the head and operable during revolution thereof to sever and free the portion of the binding material running to the completed tie, and for holding the other portion of the severed binding material.

11. In a device of the character described, a frame, work conducting means having an open portion exposing the work, tying means adjacent the open portion including cooperating needle and shuttle portions, a source of tying material, means for operating said portions to tie such material about the work, including a rotatable head for carrying the tying material about the work, the shuttle having a tapered end portion and having a side portion cut away back of said tapered end, the shuttle having an opening there-through through which the tying material may be conducted, and the tapered portion being slotted from its end to said cut away portion, said tapered portion also having an opening therein adapted to interfit with the needle, and the needle having a hooked extremity extensible through the tapered end of the needle into engagement with tying material lying in the cut away portion.

12. In a device of the character described, a frame, work conducting means carried by the frame, a source of tying material, means for tying the tying material about the work including needle and shuttle portions relatively movable in substantially coaxial paths, the shuttle having an opening therein for conducting the tying material to a position reachable by the needle, said shuttle being rotatable and reciprocable and having a slotted and tapered nose portion into which the needle is adapted to fit, a head rotatable in an orbit about the work and adapted to carry tying material extending from the shuttle about the work, the needle having a hooked extremity engageable with the tying material behind the end of the shuttle, whereby by rotation of the head the tying material may be carried about the work, by rotation of the shuttle a loop of the tying material may be formed, and by relative reciprocation of the needle and shuttle part of the tying material remote from the portion looped about the nose of the shuttle may be pulled through the loop to form a tie, such looped portion being readily pulled off the tapered nose of the shuttle, and the portion of the tying material pulled therethrough by the needle being releasable from the shuttle through the slot, and relatively timed means for moving said elements in the manners indicated.

13. In a device of the character indicated, a frame, work conducting means carried by the frame, a source of tying material, means for tying the tying material about the work including needle and shuttle portions relatively movable in substantially coaxial paths, the shuttle having an opening therein through which the tying material may be conducted from the source to a position adjacent the path of movement of the needle and the end of the shuttle, said shuttle including a portion rotatable about its axis and having a slotted and tapered nose portion adapted to interfit with the needle, a head rotatable in an orbit about the work adjacent the axial plane of the needle and shuttle, the needle having a hooked extremity engageable with the tying ma-

terial behind the end of the shuttle when inter-fitted therewith, whereby by rotation of the head the end of the tying material may be carried about the work, by rotation of the shuttle a part of such tying material may be formed into a loop, and by relative reciprocation of the needle and shuttle a portion of the tying material remote from the part looped by rotation of the shuttle may be pulled through the loop to form a tie, such looped portion being readily pulled off the tapered nose of the shuttle, and the portion of the tying material pulled therethrough by the needle being releasable from the shuttle through the slot, means carried by the head for severing the portion of the tying material extending therefrom to the work, and for gripping the portion of the tying material extending to the shuttle, and means for operating the shuttle, needle and head in relatively timed relation.

14. In a device of the character described, a frame, work conducting means carried by the frame, a source of tying material, means for tying the tying material about the work including needle and shuttle portions relatively movable in substantially coaxial paths, the shuttle having an opening therein for conducting the tying material to a position reachable by the needle, said shuttle being rotatable and having a slotted nose portion into which the needle is adapted to fit, the needle being reciprocable into and from the same, a head rotatable in an orbit about the work and adapted to carry tying material extending from the shuttle about the work, the needle having a holding extremity for and engageable with the tying material behind the end of the shuttle, whereby by rotation of the head the tying material may be carried about the work, by rotation of the shuttle a loop of the tying material may be formed, and by relative reciprocation of the needle and shuttle a part of the tying material remote from the portion looped about the nose of the shuttle may be pulled through the loop to form a tie, such looped portion being pulled off the nose of the shuttle, and the portion of the tying material pulled therethrough by the needle being releasable from the shuttle through the slot, and relatively timed means for moving said elements in the manners indicated.

15. Apparatus as set forth in claim 14 including a supply of binding material spaced from said interengaging area of the needle and shuttle, and means for conducting such material longitudinally of the axis of the shuttle to such area.

16. Apparatus as set forth in claim 14 including a supply of binding material spaced from said interengaging area of the needle and shuttle, the shuttle being hollow, means for conducting such material substantially coaxially of and through the shuttle to a point adjacent the nose thereof, the shuttle having near its nose end an additional eccentric opening through which the end of the binding material extends, gripping means for preventing travel of the binding material through the shuttle when it is desired to tighten the tie, and means for pulling upon the binding material to tighten the tie.

17. Apparatus as set forth in claim 14 including a supply of binding material carried upon a fixed support spaced from said area of interengagement of the needle and shuttle, the shuttle having a longitudinal opening therein, means for conducting the binding material longitudinally of the axis of and through the shuttle to a point adjacent the nose thereof, the shuttle having near

its nose and upon its side opposite the slot therein an eccentric opening through and from which the end of the binding material extends, whereby the end of the binding material may be wound upon
 5 the nose of the shuttle by rotation of the latter, the shuttle also having a cut away portion spaced from its nose accessible by the needle when inter-
 10 fitted therewith, means for conducting the end of the binding material about the work, after pas-
 15 sage thereof through said eccentric opening, and transversely across said cut out portion of the shuttle, whereby said portion so carried trans-
 versely across the cut out portion of the shuttle may be gripped by the needle, and by retraction of the latter carried through the nose of the shuttle
 and through the binding material wound there-
 about.

18. Apparatus as set forth in claim 14 including means for conducting the binding material to a
 20 point adjacent the nose of the shuttle, the shuttle having near its nose an eccentric opening through and from which the end of the binding material extends, whereby the end of the binding material
 25 may be wound upon the nose of the shuttle by rotation of the latter, the shuttle also having a cut away portion spaced from its nose accessible by the needle when interfitted therewith, means
 30 for conducting the end of the binding material about the work, after passage thereof through said eccentric opening, and transversely across said cut out portion of the shuttle, whereby said por-
 35 tion so carried transversely across the cut out portion of the shuttle may be gripped by the needle, and by retraction of the latter carried through the nose of the shuttle, and through the binding material wound thereabout.

19. In a device of the character described, inter-engageable needle and shuttle portions, one being reciprocable into and from interfitted relation

with the other, in a path beside the work desired to be tied, means for feeding binding material to the shuttle portion at a point adjacent the inter-
 5 engaging area of the needle and shuttle portions, means for carrying an end of the binding material about the work, means for rotating at least a part
 10 of the shuttle about an axis independent of that of the work and after the end of the binding material has been carried about the work, to form
 15 into a loop a portion of the binding material spaced from its end but adjacent the work, means for reciprocating one of said portions with respect
 to the other to pull the portion carried about the work through the loop to form a tie, and means for pulling upon the end of the cord to tighten
 the tie about the work.

20. In a device of the character described, inter-engageable needle and shuttle portions, one being reciprocable into and from interfitted relation
 20 with the other in a path beside the work desired to be tied, means for feeding binding material to the shuttle portion at a point adjacent the
 25 interengaging area of the needle and shuttle portions, means for carrying an end of the binding material about the work, means for rotating at
 30 least a part of the shuttle about an axis independent of that of the work and after the end of the binding material has been carried about the
 35 work, to form into a loop a portion of the binding material fed to such interengaging area but spaced from the end, means for reciprocating one of
 said portions with respect to another to pull the portion carried about the work through the loop to form a tie, and means reciprocable with said
 needle and shuttle portions for pulling upon both portions of the binding material leading to the tie to tighten the tie about the work.

STEPHEN L. MATOUSEK.