

J. TAYLOR.

Machine for Making Anvils.

No. 3,418.

Patented Jan'y 31, 1844.

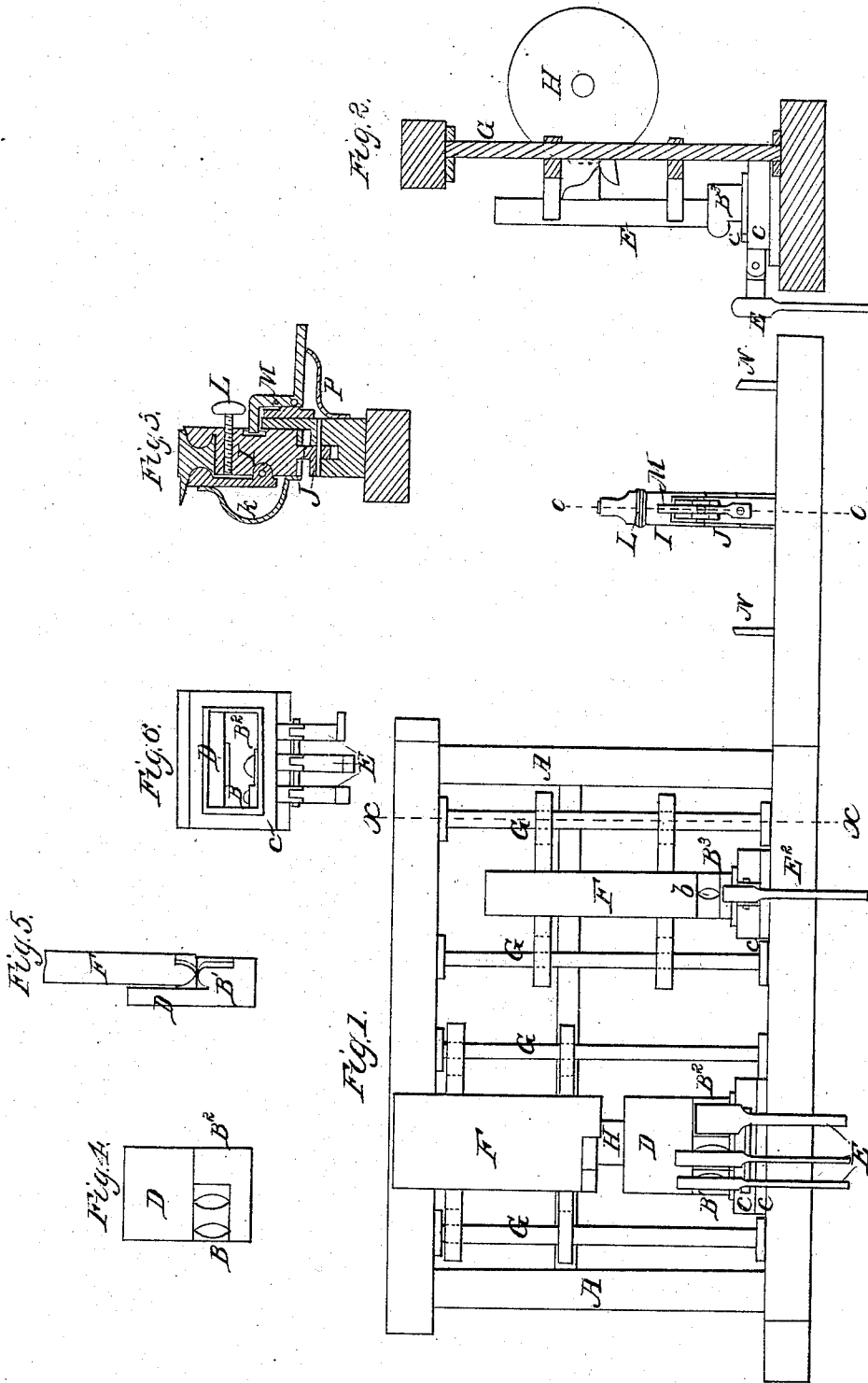

UNITED STATES PATENT OFFICE.

JOHN TAYLOR, OF SHADE GAP, PENNSYLVANIA.

MACHINE FOR MAKING ANVILS.

Specification of Letters Patent No. 3,418, dated January 31, 1844.

To all whom it may concern:

Be it known that I, JOHN TAYLOR, of Shade Gap, Huntingdon county, State of Pennsylvania, have invented a new and useful Machine for Making Anvils, which is described as follows, reference being had to the annexed drawings of the same, making part of this specification.

Figure 1 is a front elevation of the machine. Fig. 2 is a vertical transverse section *a x x* of Fig. 1. Fig. 3 is a vertical section at *o o* of Fig. 1. Fig. 4 is a front view of the bed on which the anvil is formed and of the vertical face. Fig. 5 is an end view of ditto and the hammer. Fig. 6 is a top view of ditto.

The frame of this machine lettered A in the annexed drawings may be constructed in the manner here represented, or in any convenient way, of suitable size, strength and material for the purpose intended.

B¹ B² B³ is the bed upon which the anvil is formed. This is made with depressions or cavities on the front, back and ends to correspond with the shape of the horn, feet, and ears of the anvil formed therein, and with protuberances to correspond with the cavities required in the ends and sides of the anvil. B¹ is the part of the bed upon which the ends and horn are shaped, B² the part upon which the sides are shaped; and B³ the part upon which the top and bottom are shaped.

C represents the box in which the bed is placed and in which it is adjusted by screws or wedges. D is the vertical face, gage, or rest, placed in a vertical position against the back of the bed and secured thereto by screws or bolts or by other means; or it may be cast with the bed. The piece of iron to be shaped or hammered into the form of an anvil is placed against this face or gage and held thereto by levers.

E are the levers for holding the block of iron against the face or gage. F represents the hammer for hammering the piece of iron placed on the bed into shape or form of an anvil, being made to descend in a vertical line thereon by means of vertical parallel guides G fixed in the frame.

H is a cam wheel for lifting the hammers, see Fig. 2.

I is a jointed clamp for holding the anvil while welding on the steel.

K is a spring for holding one side or jaw of the clamp against the anvil.

L is a screw for opening the jaw of the clamp.

J is a joint on which the clamp turns.

M is a dog for holding the clamp in a vertical position.

N N are two side anvils or beds with horizontal surfaces upon which the anvil is alternately brought for finishing its sides during the operation of welding on the steel.

P is a spring for holding the dog in contact with the clamp.

Operation: Take a piece of iron for a common size anvil say about 16 inches long and 6 inches square and place it upon the bed B¹—raise the lever and press the iron firmly against the vertical face-gage—start the cam shaft and raise the hammer and let it fall by its weight upon the iron—a few blows will force the iron into the cavities of the bed and form the feet and horn of the anvil. The anvil is then removed and turned over on the side face or bed B² the horn being on the right in which position it is held by a pair of tongs and the lever, by which it is managed upon the bed as desired while the hammer descends upon it to form the sides of the anvil. The hammer rises and falls close against the side of the vertical face gage or vertical rest. This operation being completed the anvil is taken to the bed with a horizontal flat face B³ and placed thereon with its face upward where it is subjected to a number of blows from the hammer which in part completes the face. It is then placed in front of the same bed with the under part of the horn in the cavity *b* and held firmly in that position by the lever E² while the hammer is working, on the top of the horn. The anvil is then taken out of the bed and the side of the horn brought under the hammer. This forms the square part of the horn. The conical part is finished in the usual manner.

The anvil is then ready to have the steel laid thereon. To perform this part of the work the anvil must be put into the jointed clamp I and secured therein by the spring K and worked in a vertical position as shown in the drawing; and also on the sides upon the side anvils, N.

The piece of iron designed for making an anvil is to be subjected alternately to the operation of the several faces as often as may be found necessary in bringing the anvil to a proper shape and finish.

I make no claim to the frame, hammers, and guides.

What I claim is—

1. The bed on which the anvil is formed,
5 shaped to correspond with the required
form of the anvil in combination with the
vertical face rest or gage, as set forth.

2. Likewise the jointed clamp in combination with the side rests or anvils.

JOHN TAYLOR.

Witnesses:

Wm. P. ELLIOT,
A. E. JOHNSON.