

(19) World Intellectual Property Organization
International Bureau



(43) International Publication Date
20 August 2009 (20.08.2009)

PCT

(10) International Publication Number
WO 2009/101627 A2

(51) International Patent Classification:
F21H 5/00 (2006.01)

(21) International Application Number:
PCT/IL2009/000174

(22) International Filing Date:
12 February 2009 (12.02.2009)

(25) Filing Language: English

(26) Publication Language: English

(30) Priority Data:
189529 14 February 2008 (14.02.2008) IL

(71) Applicants and

(72) Inventors: SHITRIT, Ezer [IL/IL]; 12 Modigliani Street, Givat Tal, 28269 Kiryat Ata (IL). AVITAL, Shlomo [IL/IL]; 20 Givat Hameyasdim Street, 98520 Maaleh Edumin (IL).

(74) Agent: SANFORD T. COLB & CO.; P.O. Box 2273, 76122 Rehovot (IL).

(81) Designated States (unless otherwise indicated, for every kind of national protection available): AE, AG, AL, AM,

AO, AT, AU, AZ, BA, BB, BG, BH, BR, BW, BY, BZ, CA, CH, CN, CO, CR, CU, CZ, DE, DK, DM, DO, DZ, EC, EE, EG, ES, FI, GB, GD, GE, GH, GM, GT, HN, HR, HU, ID, IL, IN, IS, JP, KE, KG, KM, KN, KP, KR, KZ, LA, LC, LK, LR, LS, LT, LU, LY, MA, MD, ME, MG, MK, MN, MW, MX, MY, MZ, NA, NG, NI, NO, NZ, OM, PG, PH, PL, PT, RO, RS, RU, SC, SD, SE, SG, SK, SL, SM, ST, SV, SY, TJ, TM, TN, TR, TT, TZ, UA, UG, US, UZ, VC, VN, ZA, ZM, ZW.

(84) Designated States (unless otherwise indicated, for every kind of regional protection available): ARIPO (BW, GH, GM, KE, LS, MW, MZ, NA, SD, SL, SZ, TZ, UG, ZM, ZW), Eurasian (AM, AZ, BY, KG, KZ, MD, RU, TJ, TM), European (AT, BE, BG, CH, CY, CZ, DE, DK, EE, ES, FI, FR, GB, GR, HR, HU, IE, IS, IT, LT, LU, LV, MC, MK, MT, NL, NO, PL, PT, RO, SE, SI, SK, TR), OAPI (BF, BJ, CF, CG, CI, CM, GA, GN, GQ, GW, ML, MR, NE, SN, TD, TG).

Published:

— without international search report and to be republished upon receipt of that report (Rule 48.2(g))

(54) Title: LAMP WITH HEAT-RESPONSIVE DECORATION

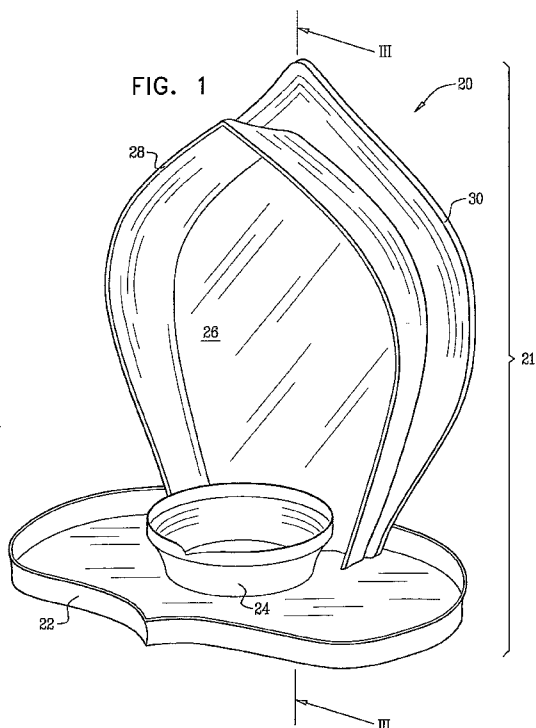

(57) Abstract: A lighting product including a holder for an illumination source, a frame, attached to the holder including a back plate having a front surface adjacent to the illumination source, and a layer of a thermo-chromic material, which is disposed on the front surface of the back plate so as to alter an appearance of the back plate in response to heat emitted by the illumination source.

LAMP WITH HEAT-RESPONSIVE DECORATION**FIELD OF THE INVENTION**

The present invention relates generally to decorative lighting, and specifically to lamp and candle holders.

BACKGROUND OF THE INVENTION

The use of thermochromic materials in decorative lighting is known in the art. For example, U.S. Patent 6,544,448, whose disclosure is incorporated herein by reference, describes a luminary device with a thermochromic label. A decorative web of heat-shrinkable polymer is heat-shrunk to conform to the shape of a candle or candle holder. The web is decorated with a thermochromic ink or pigmentation, which changes visibly when the candle is burned.

SUMMARY OF THE INVENTION

In embodiments of the present invention, a lighting product comprises a holder for an illumination source, such as a candle, and a frame, which is attached to the holder. The frame comprises a back plate having a front surface adjacent to the illumination source. A layer of a thermochromic material, disposed on the front surface of the back plate, alters the appearance of the back plate in response to heat emitted by the illumination source.

In a disclosed embodiment, the thermochromic material is opaque at ambient temperature and becomes transparent in response to the heat emitted by the illumination source. An image on the front surface of the back plate, beneath the layer of the thermochromic material, becomes visible as the thermochromic material becomes transparent. The layer of the thermochromic material may optionally comprise a second image, which is visible at the ambient temperature and becomes

transparent in response to the heat so as to reveal the first image.

The present invention will be more fully understood from the following detailed description of the embodiments thereof, taken together with the drawings in which:

BRIEF DESCRIPTION OF THE DRAWINGS

Fig. 1 is a schematic, pictorial illustration of a lighting product, in accordance with an embodiment of the present invention;

Figs. 2A and 2B are schematic, pictorial illustrations showing a reaction of the lighting product of Fig. 1 to heat emitted by a candle, in accordance with an embodiment of the present invention; and

Fig. 3 is a schematic, sectional illustration of the lighting product of Fig. 1, in accordance with an embodiment of the present invention.

DETAILED DESCRIPTION OF EMBODIMENTS

Fig. 1 is a schematic, pictorial illustration of a lighting product 20, in accordance with an embodiment of the present invention. Product 20 comprises a frame 21, comprising a base 22 and a back plate 26 mounted on the base. A holder 24 for an illumination source is also mounted on base 22. In this embodiment, holder 24 is designed to hold a candle, but the holder may alternatively be adapted to hold any suitable sort of illumination source, such as an electric lamp or oil with a wick, which serves as an oil lamp.

Back plate 26 is roughly perpendicular to base 22. The front surface of back plate 26 (i.e., the surface that is seen by a user or viewer of product 20 and is shown in this figure), adjacent to holder 24, is covered by a layer of thermochromic material, which responds to heat emitted by the

illumination source, as is described further with reference to the figures that follow. Back plate 26 may also comprise a canopy 28, which extends forward over the illumination source in holder 24 and may help in capturing the heat emitted by the illumination source. A protective plate 30 may be mounted behind the back surface of the back plate in order to protect people and objects from exposure to the hot back plate. Although the elements of frame 21 are shown in Fig. 1 as having a certain geometry and decorative features, these aspects of product 20 are shown only by way of illustration. Alternative geometries and features that fulfill the functions described herein are likewise considered to be within the scope of the present invention.

Reference is now made to Figs. 2A and 2B, which are schematic, pictorial illustrations showing the reaction of product 20 to heat emitted by a candle 32 in holder 24. Fig. 2A shows the appearance of back plate 26 immediately after lighting the candle, whereas Fig. 2B shows the change in appearance of the back plate after heating by the candle for a period of time.

An image 34 is disposed on the front surface of back plate 26, and a layer of thermochromic material is formed over the image. The thermochromic material is chosen so that at ambient temperature (for example, in the range of 20°C), the thermochromic layer is opaque, and image 34 is hidden from view, as shown in Fig. 1. As the temperature of back plate 26 rises, the thermochromic material gradually becomes transparent, and image 34 is revealed, as shown in Figs. 2A and 2B. The thermochromic layer may be uniform, so that back plate 26 is blank until heated by candle 32. Alternatively, the thermochromic material may comprise a second image (not shown), overlying image 34, so that the second image is

visible at ambient temperature and becomes transparent in response to the heat from candle 32 so as to reveal the first image.

Fig. 3 is a schematic, sectional view of product 20, taken along the line III-III in Fig. 1, in accordance with an embodiment of the present invention. Typically, base 22, back plate 26 and protective plate 30 are made from a suitable metal, such as brass. Alternatively, some or all of these parts may be made from other materials, such as ceramic, glass, or heat-resistant plastic. Although a back surface 40 of back plate 26 is shown in this figure as being in contact with protective plate 30, there may alternatively be an air gap or other insulating layer between surface 40 and plate 30.

A layer 44 of pigment, defining image 34, is disposed on a front surface 42 of back plate 26 and is overlaid by a layer 46 of thermochromic material. Layers 44 and 46 may be printed directly onto surface 42, or they may alternatively be printed on a substrate, such as chromo paper, which is then glued onto or otherwise affixed to the surface. Layer 44 may comprise any suitable ink, and image 34 is typically printed in this layer using a standard monochrome or four-color printing process.

Layer 46 may comprise any suitable type of thermochromic material, such as a leuco-based ink or pigment, as is known in the art. The type of material and thickness of layer 46 are chosen so that the layer becomes transparent at the desired temperature. In the kind of design shown in Figs. 1-3, using candle 32 as the source of heat, layer 46 is typically printed to a thickness of 1.5 - 2 μm . A dark-colored leuco dye may be advantageous to hide image 34 completely until back plate 26 is heated. A second image, which is seen when back plate 26

is at ambient temperature, may be printed in layer 46 or over layer 46 using an additional thin layer of thermochromic ink.

Alternatively, layer 44 may be omitted, and the desired image may be formed in layer 46 using a suitable thermochromic material so that the image is invisible at ambient temperature and becomes visible when the thermochromic material is heated.

It will be appreciated that the embodiments described above are cited by way of example, and that the present invention is not limited to what has been particularly shown and described hereinabove. Rather, the scope of the present invention includes both combinations and subcombinations of the various features described hereinabove, as well as variations and modifications thereof which would occur to persons skilled in the art upon reading the foregoing description and which are not disclosed in the prior art.

CLAIMS

1. A lighting product, comprising:
 - a holder for an illumination source;
 - a frame, attached to the holder and comprising a back plate having a front surface adjacent to the illumination source; and
 - a layer of a thermochromic material, which is disposed on the front surface of the back plate so as to alter an appearance of the back plate in response to heat emitted by the illumination source.
2. The product according to claim 1, wherein the illumination source is a candle.
3. The product according to claim 1, wherein the frame comprises a base, upon which the holder and the back plate are mounted.
4. The product according to claim 3, wherein the back plate has a back surface opposite the front surface, and wherein the frame comprises a protective plate mounted on the base adjacent to the back surface of the back plate.
5. The product according to claim 1, wherein the back plate comprises a canopy that extends forward over the illumination source.
6. The product according to claim 1, wherein the thermochromic material is opaque at an ambient temperature of the product and becomes transparent in response to the heat emitted by the illumination source.
7. The product according to claim 6, wherein an image is disposed on the front surface of the back plate, beneath the layer of the thermochromic material, so that the image becomes visible as the thermochromic material becomes transparent.

8. The product according to claim 7, wherein the image on the front surface of the back plate is a first image, and wherein the layer of the thermochromic material comprises a second image, which is visible at the ambient temperature and becomes transparent in response to the heat so as to reveal the first image.

9. A method for lighting, comprising:

mounting a holder for an illumination source on a frame comprising a back plate so that a front surface of the back plate is adjacent to the illumination source; and

providing, on the front surface of the back plate, a layer of a thermochromic material that alters an appearance of the back plate in response to heat emitted by the illumination source.

10. The method according to claim 9, wherein the illumination source is a candle.

11. The method according to claim 9, wherein the frame comprises a base, upon which the holder and the back plate are mounted.

12. The method according to claim 11, wherein the back plate has a back surface opposite the front surface, and wherein the frame comprises a protective plate mounted on the base adjacent to the back surface of the back plate.

13. The method according to claim 9, wherein the back plate comprises a canopy that extends forward over the illumination source.

14. The method according to claim 9, wherein the thermochromic material is opaque at an ambient temperature and becomes transparent in response to the heat emitted by the illumination source.

15. The method according to claim 14, and comprising forming an image on the front surface of the back plate, beneath the layer of the thermochromic material, so that the image becomes visible as the thermochromic material becomes transparent.

16. The method according to claim 15, wherein the image on the front surface of the back plate is a first image, and wherein the method comprises forming, in the layer of the thermochromic material, a second image, which is visible at the ambient temperature and becomes transparent in response to the heat so as to reveal the first image.

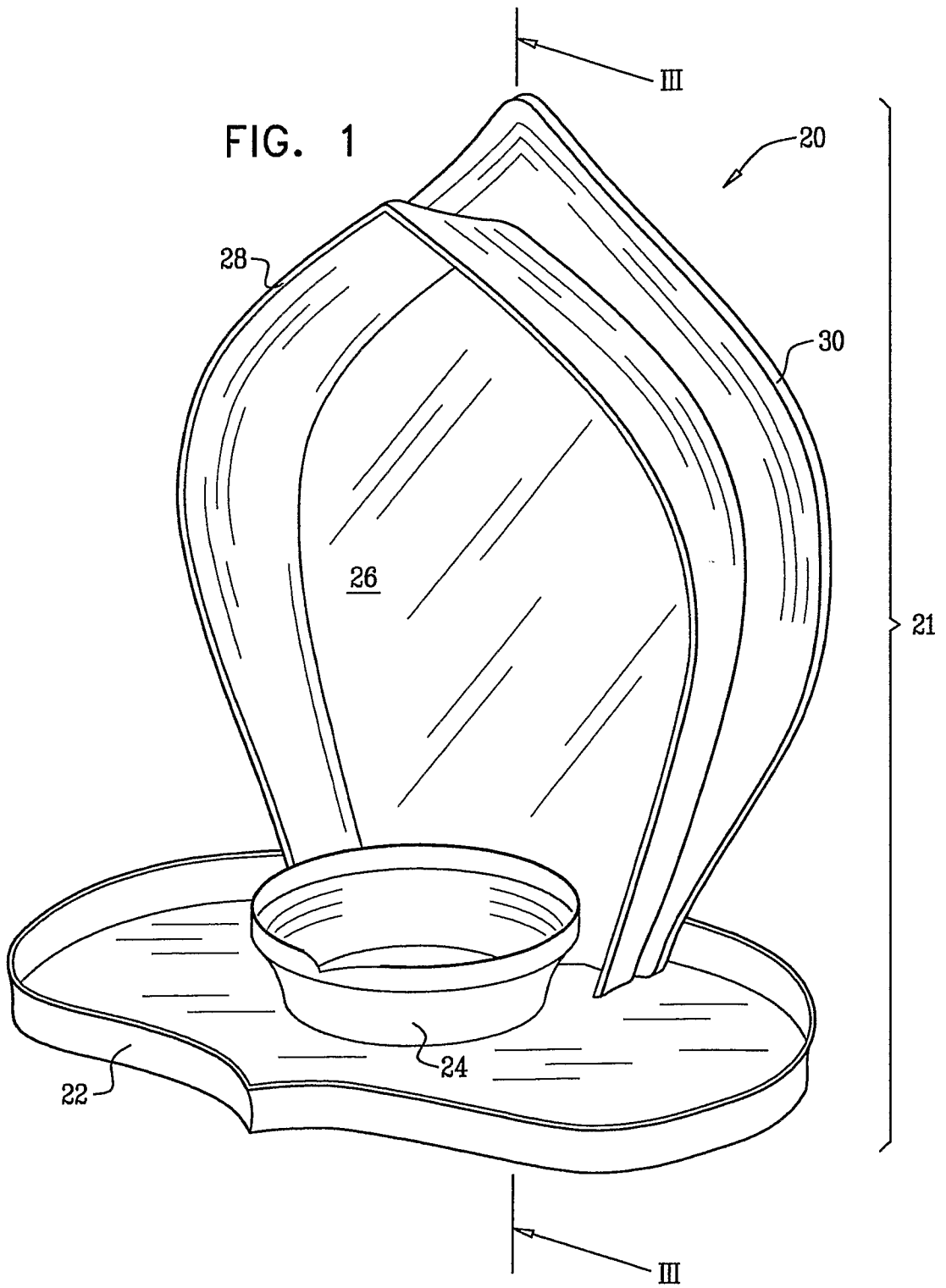

FIG. 2A

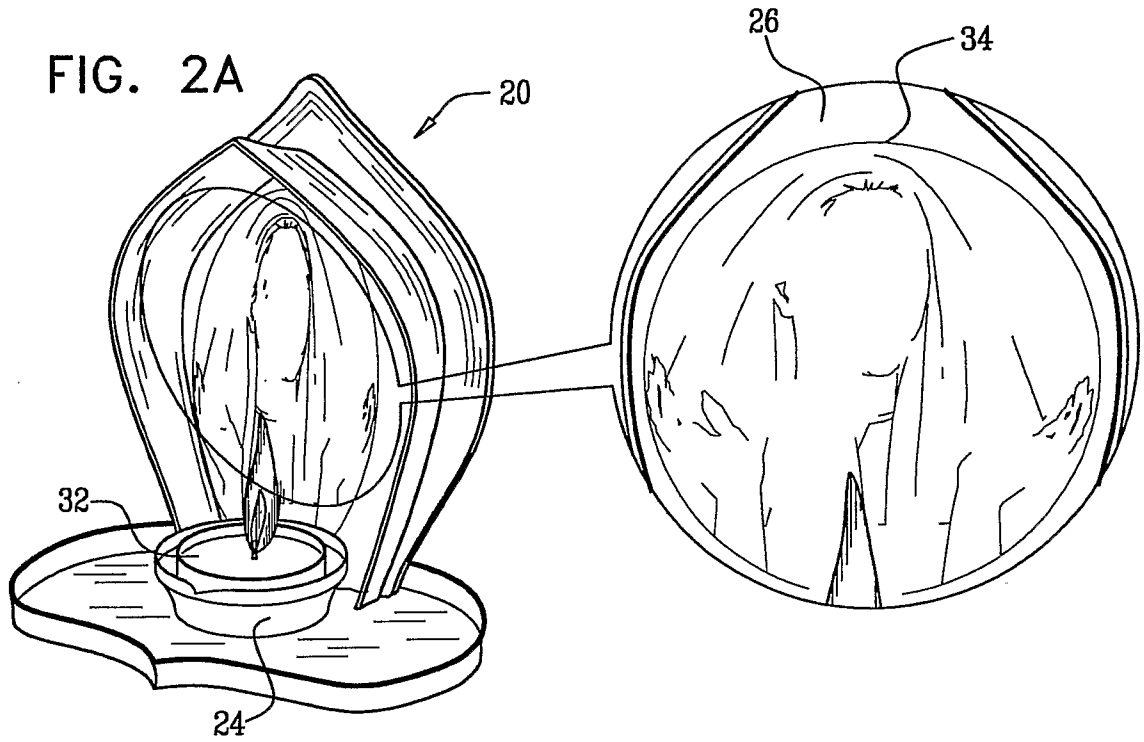

FIG. 2B

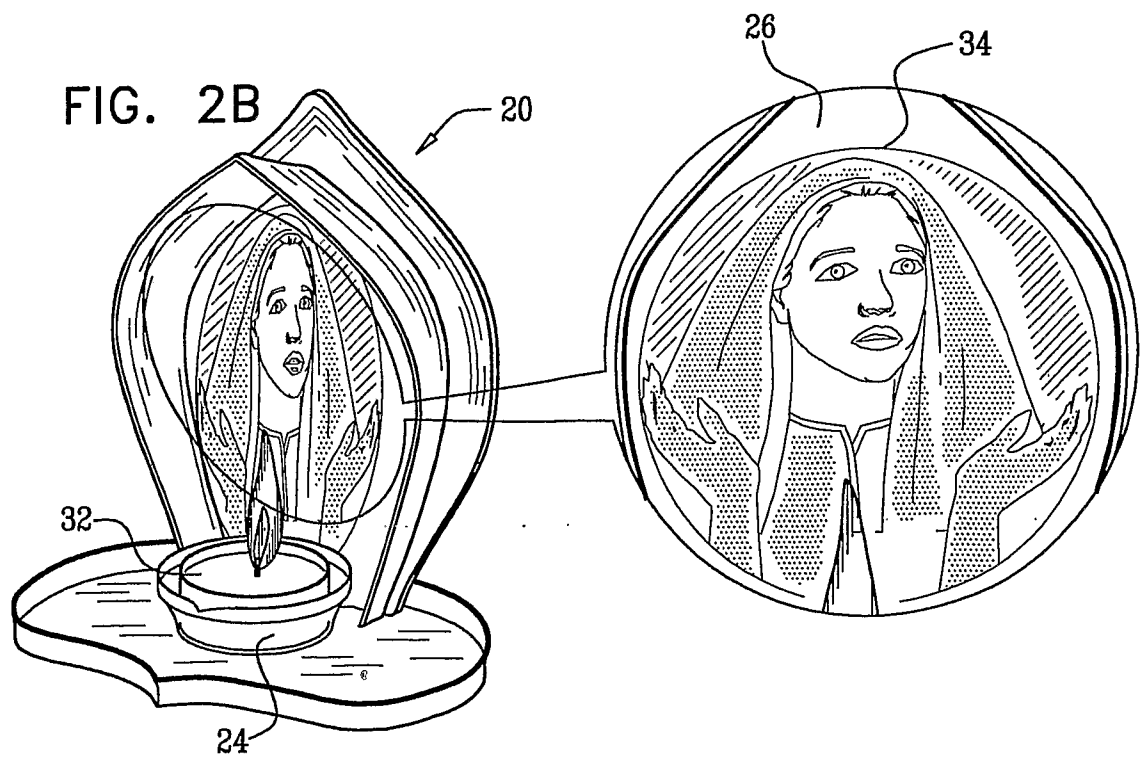

FIG. 3

