

(19)



(11)

EP 1 840 272 B2

(12)

NEW EUROPEAN PATENT SPECIFICATION

After opposition procedure

(45) Date of publication and mention
of the opposition decision:
23.09.2015 Bulletin 2015/39

(51) Int Cl.:
E01H 5/06 (2006.01)

(45) Mention of the grant of the patent:
04.01.2012 Bulletin 2012/01

(21) Application number: **07104878.9**

(22) Date of filing: **26.03.2007**

(54) **Snow clearing vehicle with snowplough blade having adjustable width**

Schneeräumfahrzeug mit Schneeräumschild mit einstellbarer Breite

Chasse-neige avec lame à largeur réglable

(84) Designated Contracting States:
**AT BE BG CH CY CZ DE DK EE ES FI FR GB GR
HU IE IS IT LI LT LU LV MC MT NL PL PT RO SE
SI SK TR**

(30) Priority: **27.03.2006 IT BO20060025**

(43) Date of publication of application:
03.10.2007 Bulletin 2007/40

(73) Proprietor: **ASSALONI . COM. S.P.A.
40042 Lizzano in Belvedere (BO) (IT)**

(72) Inventor: **Gandolfi, Fabio
40042 Lizzano in Belvedere (BO) (IT)**

(74) Representative: **Lovino, Paolo et al
Studio Torta S.p.A.
Via Viotti, 9
10121 Torino (IT)**

(56) References cited:
**JP-A- 63 022 906 US-A- 4 369 847
US-A- 4 667 426 US-A1- 2003 226 289**

EP 1 840 272 B2

Description

[0001] The present invention relates to an operative vehicle for removing snow from road surfaces, equipped with a snowplough blade.

[0002] The vehicles (agricultural tractors, trucks) are operated to adjust their snow removing front part according to the contingent needs and the characteristics of the road paths (roads with reduced width, with one or more lanes, etc.)

[0003] Different types of snowplough blades with variable width are known to those expert in the field, and substantially they include: a first stationary blade body, carried by a frame for suspension and coupling to a respective vehicle. The first stationary blade body includes, situated in its lower part, shock absorbers for coupling with a flexible scraper which bends with respect to the first blade body in the direction opposite to the blade forward movement in case of collisions with obstacles or irregularities of the road surface; a second blade body, connected with its rear part to the first blade body, by means of mutual coupling, sliding and moving with respect to the latter between an inner retracted position, in which the front of the snowplough blade is formed only by the first blade body, and an extreme advanced position, in which the front of the blade is formed by the first and second blade bodies, arranged abreast, with the second blade body situated on the right with respect to the vehicle forward movement direction and having, likewise in its lower part, shock absorbing means for coupling with a related scraper.

[0004] In particular, the Utility Model Application no. ITBO2002U 000069, of the same Applicant, is distinguished by the fact that the first stationary blade body forms, on its rear surface, facing the second moving blade body, a shoulder for supporting mutual coupling means, so as to keep the second blade body at a distance with respect to the first blade, to delimit a free space.

[0005] When the second blade body is in the inner retracted position, the scraper of the first blade body moves into the free space while bending because of collision with obstacles or irregularities of the road surface.

[0006] In spite of the many technical-functional advantages of the above mentioned solution, some drawbacks must be pointed out, with reference to the enclosed Figures related to said prior art, in which Figures 1A, 1B, 1C, 1D are corresponding plan views of the snowplough blade in several significant configurations, and Figure 4 is a scheme of a snow clearing vehicle having such a snowplough blade and having a third lateral blade in work configuration.

[0007] The snowplough blade AL includes: a first blade body AL1, supported by a structure AS for suspension and coupling with a respective operative vehicle (not shown); and a second blade body AL2, connected to the rear part of the first blade body AL1, parallel thereto, by means of mutual sliding coupling means, and moved with respect to the first body between an inner retracted

position (Figures 1A, 1C) and an extreme advanced position (Figures 1B, 1D) by operation of hydraulic jack, interposed between the structure AS and the second blade body AL2.

5 **[0008]** As it can be noted, the space occupied by the suspension and coupling structure AS connected to the first blade body AL1 defines a limit to the width of the second blade body AL2, when it is in the retracted position.

10 **[0009]** This fact limits also the maximum width of the snowplough blade AL as a whole, also considering that the maximum width of the first blade body AL1 is related to the vehicle width, for space and safety reasons.

15 **[0010]** Another width limit of the second blade body AL2 is imposed by practical reasons: actually, the vehicle driver can find it difficult to estimate the real dimension of the second blade body AL2 in in extreme advanced position (see for instance Figure 1D) during the snow clearing, due to the his unfavorable position in the cabin (conventionally on the left).

20 **[0011]** This obviously results in a high risk of collisions and damages to the objects out of the road.

25 **[0012]** Another disadvantage of this configuration results from a limited, or lacking, utility of the lateral snowplough blade, situated on the right side (with respect to the forward movement direction) of some vehicles, when the second blade body AL2 is brought to the extreme advanced position (see Figure 4).

30 **[0013]** Therefore, the object of the present invention is to propose an operative vehicle for removing snow from road surfaces, having a snowplough blade with adjustable width, which can avoid the reported disadvantages of the prior art.

35 **[0014]** Another object of the present invention is to propose such a vehicle with a snowplough blade, that, in minimum front width condition, allows the operative vehicle, to which it is connected, to operate in symmetry condition, and that, in maximum front width condition, makes up a total dimension wider than the known solutions.

40 **[0015]** A further object of the present invention is to propose such a vehicle with a snowplough with adjustable width, obtained according to a reliable and functional technical solution, whose costs are relatively limited with respect to the purposes to be obtained.

45 **[0016]** The above mentioned objects are obtained in accordance with the contents of the claims.

50 **[0017]** The characteristic features of the invention, which do not appear from what has been just said, will be better pointed out in the following, in accordance with the contents of the claims and with the help of the enclosed figures, in which:

- Figures 1A, 1B, 1C, 1D are corresponding plan views of a known technical solution (in this case the one described in the Application BO2002U 000069);
- Figures 2A, 2B, 2C, 2D are plan views of the snow-

plough blade proposed by the invention;

- Figure 2E is a partial, perspective view of the snowplough blade according to the invention;
- Figure 2F is a schematic, rear and partial view of the snowplough blade according to the invention;
- Figure 3 is a schematic, top view, comparing two possible positions of the driver's cabin in a snowplough carrying vehicle according to the invention and to the prior art;
- Figure 4 is a schematic, top view of a snowplough carrying vehicle of known type, equipped with a lateral blade;
- Figure 5 is a schematic, top view of a vehicle according to the invention, further equipped with a lateral blade.

[0018] With regard to the enclosed Figures, the reference L indicates the snowplough blade with adjustable width as a whole, proposed by the present invention. The snowplough blade L includes a first, stationary blade body L1, supported by a frame S, of a type known to those skilled in the field and thus not described in detail in its various elements, for suspension and coupling with a respective operative vehicle O (shown schematically only in Figures 4, 5).

[0019] A second blade body L2 is connected to the front of the first blade body L1, parallel thereto, by mutual coupling means of sliding type (not shown as known), and is operated to move in translation with respect thereto, by corresponding actuating means A, connected to said suspension frame S, between a retracted position R, in which the snow-removing surface of the snowplough blade L is formed only by the second blade body L2 (Figures 2A, 2C), and an extreme advanced position EA, in which the snow-removing surface of the snowplough blade L is formed by two blade bodies L1, L2, arranged one beside the other and with the second blade body L2 on the left of the first one (Figures 2B, 2D).

[0020] The first blade body L1 includes a tubular cross-beam 1, shaped in a suitable way to be connected externally to the suspension and coupling frame S.

[0021] Moreover, the tubular cross-beam 1 houses the actuating means A, including a hydraulic jack, whose ends are fastened respectively to the cross-beam 1 and to the second blade body L2.

[0022] According to the example shown in Figure 2F, the inner end G of the jack A, coupling it to the tubular cross-beam 1 is situated near the center line of the frame S.

[0023] It is to be noted that the snowplough blade L is symmetrical to the center line of the machine O when the snow-removing surface is minimum, that is when the second blade body L2 is in the retracted position R.

[0024] According to the present invention, the connection of the suspension and coupling frame S to the tubular cross-beam 1, integral part of the first blade body L1, is not a limit for the width dimension of the second blade body L2, and consequently of the moving part of the snowplough blade L, as it occurred in the prior art and as it is possible to deduce comparing Figures 2A, 2B, 2C, 2D, with Figures 1A, 1B, 1C, 1D.

[0025] For example, once the width of the second blade body L2 has been determined (equal to the minimum snow-removing surface of the snowplough blade L), the first blade body L1 can have variable dimensions, up to a width comparable with the width of the second blade body L2.

[0026] This is made possible by providing a hydraulic jack extending along the whole length of the tubular cross-beam 1.

[0027] Therefore, advantageously, it is possible to obtain snowplough blades with adjustable width, with a long stroke between the minimum and maximum snow removing surfaces, thus avoiding successfully the disadvantages of the prior art reported in the introductory note. In this way, it is possible to adapt the snow-removing surface of the snowplough blade L to a variety of road and highway paths, in relation to their width, thus obtaining a considerable operation flexibility.

[0028] Figure 3 shows schematically, indicated with a continuous and broken lines, the position of the cabin of the machine O with respect to the snowplough blade L, in the maximum snow-removing surface configuration, respectively according to the invention and to the prior art.

[0029] As it can be seen, according to the present invention, the driver's position is closer to the first blade body L1 and this allows the driver to drive the operative vehicle O safely and to position the snowplough blade L in a better way close to the right side of the road, thus reducing considerably the risk of collision with, and/or damages to, objects out of the road.

[0030] Another advantage of the present invention can be seen in operative vehicles O having a lateral blade 2, situated on their right with respect to the movement direction (see Figure 5).

[0031] In this case, the total snow-removing surface removing the snow from the road surface is further increased.

[0032] Another advantage of the invention lies in the fact that it has conceived a snowplough blade with adjustable width, obtained according to a reliable and functional technical solution, whose costs are relatively contained with respect to the achieved advantages.

[0033] It is understood that the matter contained in the above description or shown in the corresponding drawings shall be interpreted as a mere, not limiting example. Many changes could be made to the above construction without departing from the scope thereof as defined in the following claims.

Claims

1. Operative vehicle for removing snow from road surfaces, equipped with a snowplough blade (L) with adjustable width, said snowplough blade (L) having a snow-removing surface and being formed by:

a first blade body (L1), supported stationary and coupled to the front of said operative vehicle (O) by means of a suspension frame (S); and
 a second blade body (L2), slidingly connected to said first blade body (L1), parallel thereto, by mutual coupling means, and operated by actuating means (A) connected to said suspension frame (S), so that said second blade body (L2) moves, with respect to said first blade body (L1), between a retracted position (R), in which said snow-removing surface of said snowplough blade (L) is minimum and an extreme advanced position (EA), in which the snow-removing surface of said snowplough blade (L) is maximum and is formed by said first and second blade bodies (L1,L2), arranged one beside the other wherein said second blade body (L2) is situated in front of said first blade body (L1), wherein the operation of the second blade body (L2) to said extreme advanced position (EA) is determined by its sliding leftwards with respect to the first blade body (L1) and to the movement direction of the vehicle, wherein when the second blade body (L2) is in said retracted position (R), the snow-removing surface of the snowplough blade (L) is symmetrical to a center line of the vehicle (O), the operative vehicle (O) being **characterized in that** when the second blade body (L2) is in said retracted position (R), the snow-removing surface of the snowplough blade (L) is formed only by the second blade body (L2), and **in that** said first blade body (L1) includes a tubular cross-beam (1), which is connected to said suspension, and coupling frame (S) and whose inner space is occupied, at least partially, by said actuating means (A).

2. Operative vehicle, according to claim 1, **characterized in that** said actuating means (A) include a hydraulic jack housed inside said tubular cross-beam (1) and functionally interposed between the tubular cross-beam (1) and said second blade body (L2).

Patentansprüche

1. Arbeitsfahrzeug zum Räumen von Schnee von Straßenoberflächen, ausgestattet mit einem Schneeräumschild (L) mit einstellbarer Breite, wobei das Schneeräumschild (L) eine Schneeräumoberfläche

aufweist und gebildet wird aus:

einem ersten Scharkörper (L1), der stationär getragen wird und an der Vorderseite des Arbeitsfahrzeugs (0) mit einem Aufhängungsrahmen (S) angekoppelt ist; und
 einem zweiten Scharkörper (L2), der durch Mittel zur gegenseitigen Kupplung gleitbar mit dem ersten Scharkörper (L1) verbunden ist, parallel zu diesem ist und durch Stellantriebsmittel (A) betätigt wird, die mit dem Aufhängungsrahmen (S) verbunden sind, so dass sich der zweite Scharkörper (L2) relativ zu dem ersten Scharkörper (L1) bewegen kann zwischen einer eingefahrenen Stellung (R), in der die Schneeräumoberfläche des Schneeräumschildes (L) ihr Minimum erreicht, und einer extrem ausgefahrenen Stellung (EA), in der die Schneeräumoberfläche des Schneeräumschildes (L) ihr Maximum erreicht und durch die nebeneinander angeordneten ersten und zweiten Scharkörper (L1, L2) gebildet wird; wobei der zweite Scharkörper (L2) vor dem ersten Scharkörper (L1) angeordnet ist, wobei die Betätigung des zweiten Scharkörpers (L2) zum Einnehmen der extrem ausgefahrenen Stellung (EA) dessen seitliches Verschieben nach links relativ zu dem ersten Scharkörper (L1) und zu der Fahrtrichtung des Fahrzeuges bewirkt, und wobei, wenn sich der zweite Scharkörper (L2) in der eingefahrenen Stellung (R) befindet, die Schneeräumoberfläche des Schneeräumschildes (L) symmetrisch zu einer Mittellinie des Fahrzeuges (0) ist; das Arbeitsfahrzeug (0) ist **dadurch gekennzeichnet, dass**, wenn sich der zweite Scharkörper (L2) in der eingefahrenen Stellung (R) befindet, die Schneeräumoberfläche des Schneeräumschildes (L) nur durch den zweiten Scharkörper (L2) gebildet wird und dass der erste Scharkörper (L1) einen rohrförmigen Querträger (1) beinhaltet, der mit dem Aufhängungs- und Kupplungsrahmen (S) verbunden ist und dessen Innenraum, zumindest teilweise, durch die Stellantriebsmittel (A) belegt ist.

2. Arbeitsfahrzeug nach Anspruch 1, **dadurch gekennzeichnet, dass** die Stellantriebsmittel (A) eine hydraulische Winde beinhalten, die in dem röhrenförmigen Querträger (1) untergebracht und funktional zwischen dem röhrenförmigen Querträger (1) und dem zweiten Scharkörper (L2) angeordnet ist.

Revendications

1. Véhicule opérateur pour enlever la neige de surfaces

de routes, équipé d'une lame chasse-neige (L) avec une largeur réglable, ladite lame chasse-neige (L) ayant une surface d'enlèvement de la neige et étant constituée d'un premier corps de lame (L1), supporté de manière stationnaire et couplé à l'avant dudit véhicule opérateur (O) à l'aide d'un châssis de suspension (S) ; et

d'un deuxième corps de lame (L2), relié de manière coulissante audit premier corps de lame (L1) parallèlement à celui-ci, à l'aide de moyens de couplage mutuels, et actionné à l'aide de moyens d'actionnement (A) reliés audit châssis de suspension (S), de façon à ce que ledit deuxième corps de lame (L2) se déplace par rapport audit premier corps de lame (L1), entre une position rétractée (R), dans laquelle ladite surface d'enlèvement de la neige de ladite lame chasse-neige (L) est minimale et une position avancée extrême (EA), dans laquelle ladite surface d'enlèvement de la neige de ladite lame chasse-neige (L) est maximale et est formée par lesdits premier et de deuxième corps de lame (L1, L2) disposés l'un à côté de l'autre, ledit deuxième corps de lame (L2) étant situé devant ledit premier corps de lame (L1), le déplacement du deuxième corps de lame (L2) vers ladite position avancée extrême (EA) étant déterminée par son coulissement vers la gauche par rapport au premier corps de lame (L1) et à la direction du mouvement du véhicule,

lorsque le deuxième corps de lame (L2) est dans ladite position rétractée (R), la surface d'enlèvement de la neige de la lame chasse-neige (L) étant symétrique à une ligne centrale du véhicule (O),

le véhicule opérateur (O) étant **caractérisé en ce que**, lorsque le deuxième corps de lame (L2) est dans ladite position rétractée (R), la surface d'enlèvement de la neige de la lame chasse-neige (L) est formée seulement par le deuxième corps de lame (L2) et **en ce que** ledit premier corps de lame (L1) comprend une poutre transversale tubulaire (1) qui est reliée audit châssis de suspension et de couplage (S) et dont l'espace interne est occupé au moins partiellement par lesdits moyens d'actionnement (A).

2. Véhicule opérateur selon la revendication 1, **caractérisé en ce que** lesdits moyens d'actionnement (A) comprennent un vérin hydraulique logé à l'intérieur de ladite poutre transversale tubulaire (1) et interposé, de manière fonctionnelle, entre la poutre transversale tubulaire (1) et ledit deuxième corps de lame (L2).

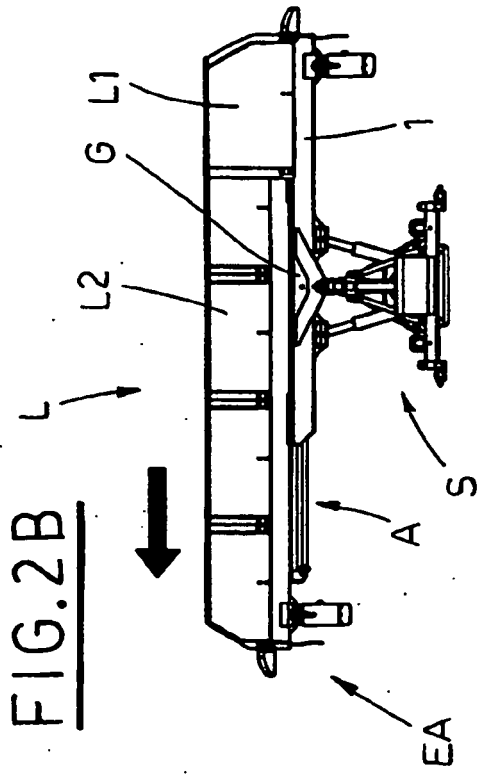

FIG. 2B

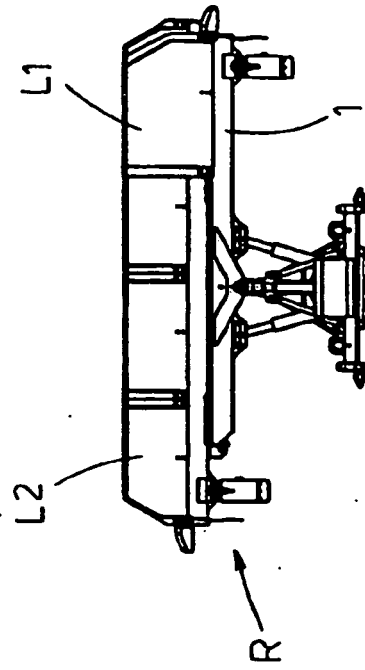

FIG. 2A

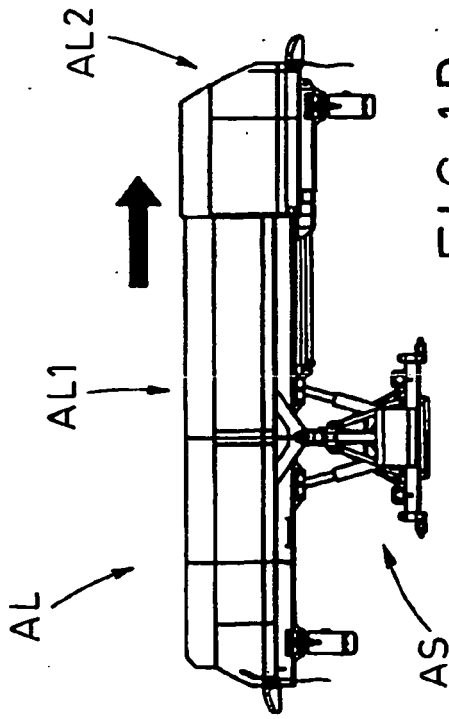

FIG. 1B

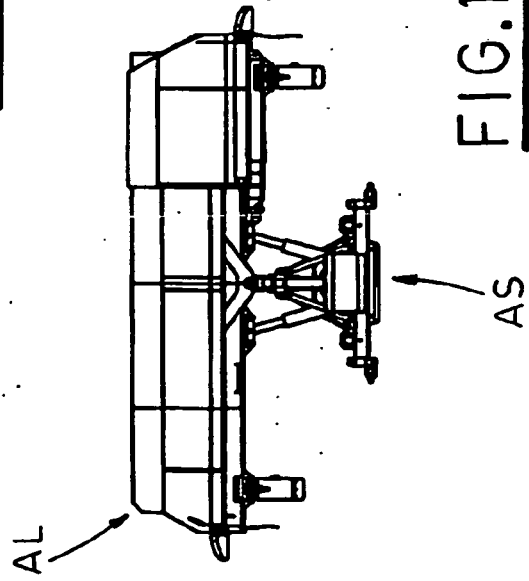
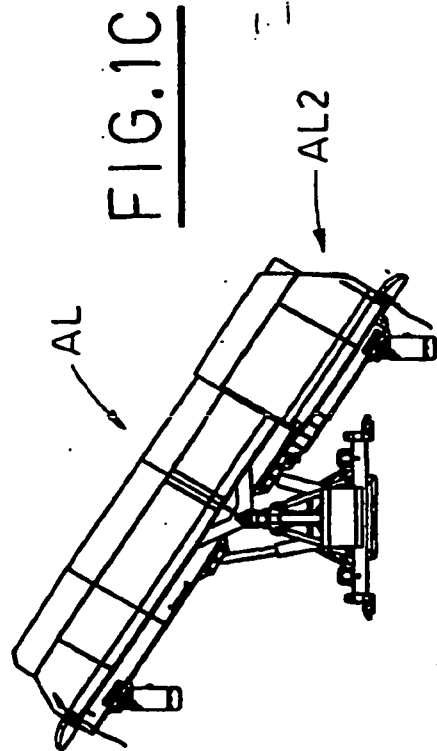
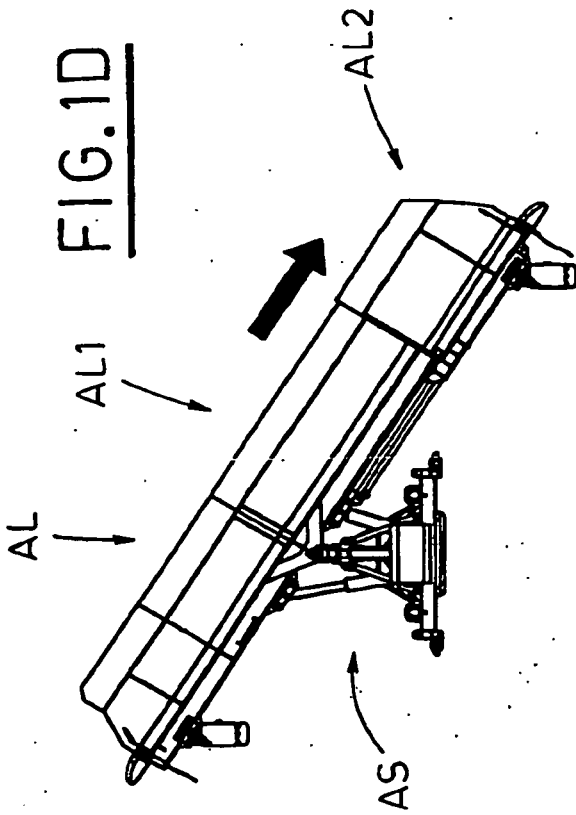
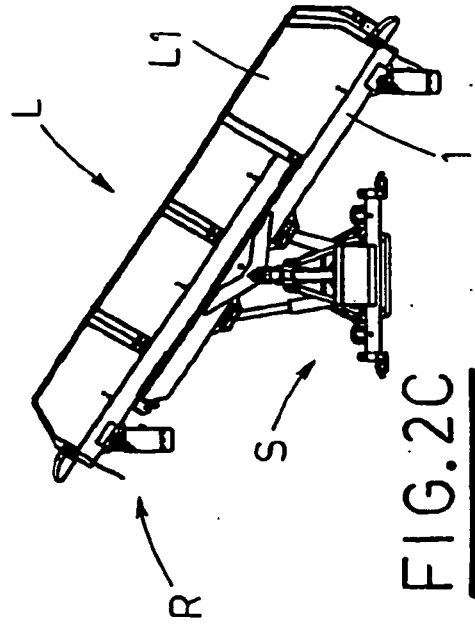
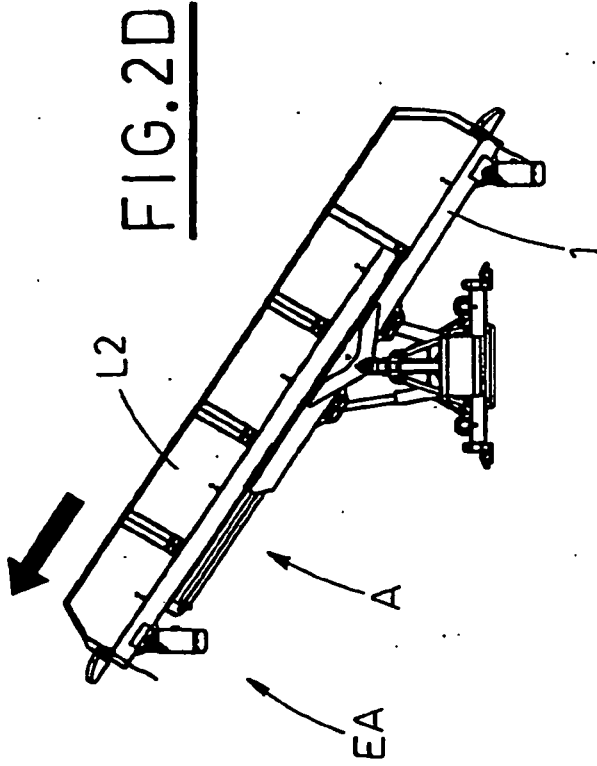
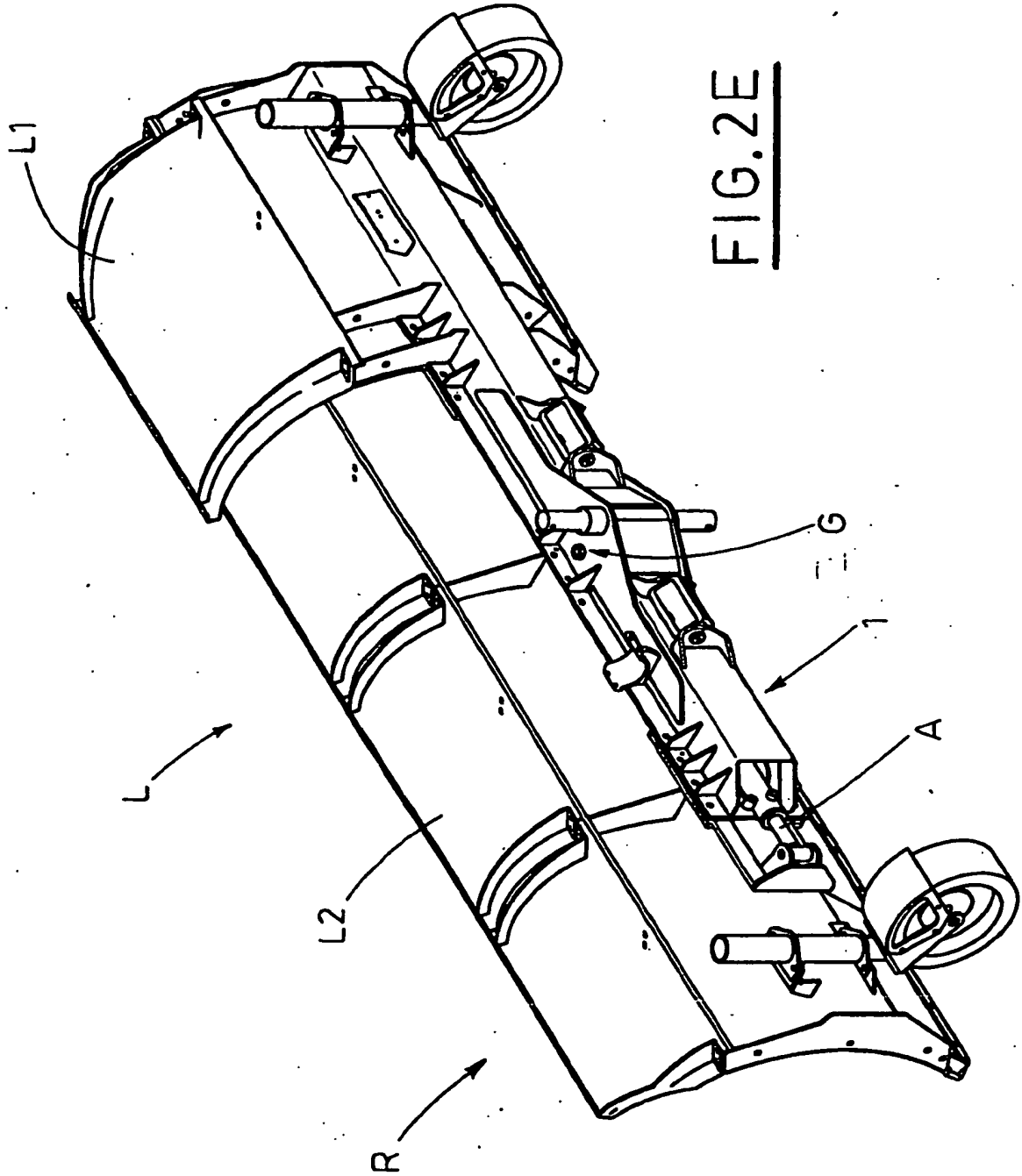

FIG. 1A





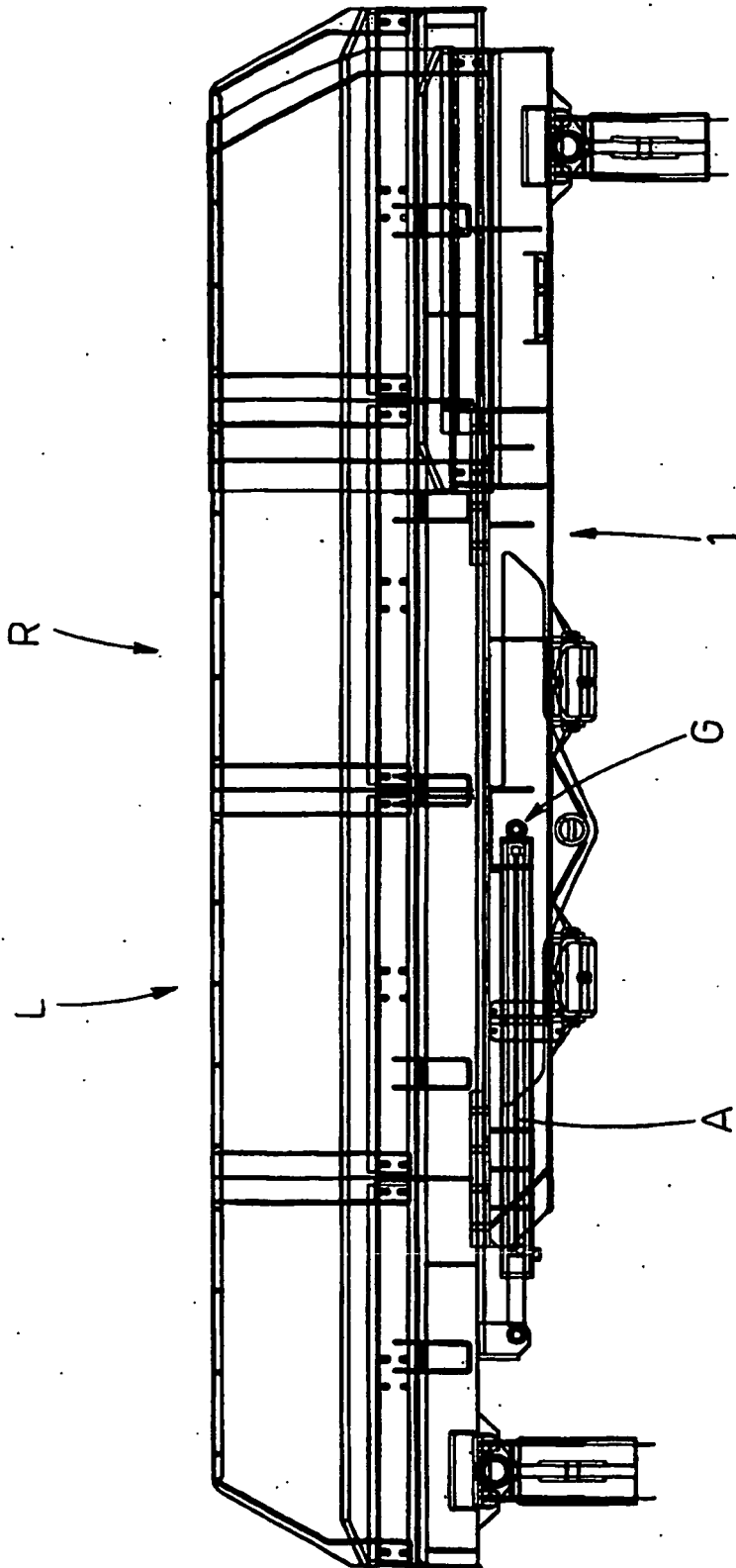

FIG. 2F

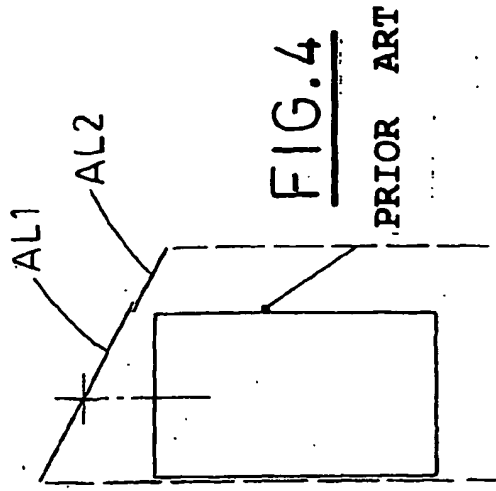

FIG. 4

PRIOR ART

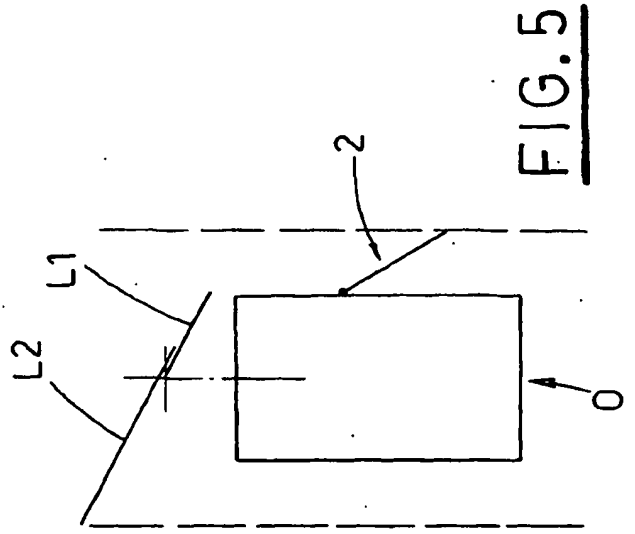

FIG. 5

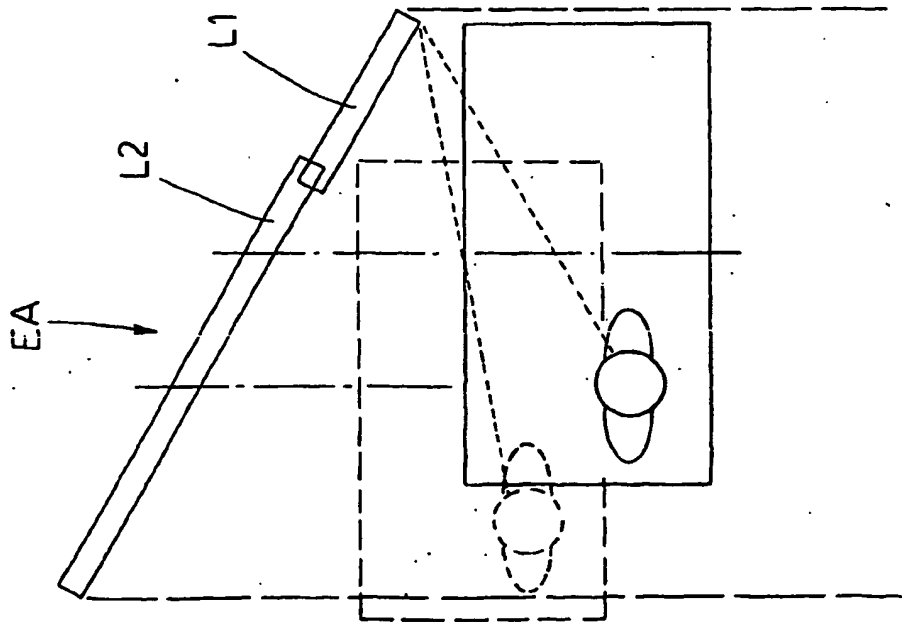

FIG. 3

REFERENCES CITED IN THE DESCRIPTION

This list of references cited by the applicant is for the reader's convenience only. It does not form part of the European patent document. Even though great care has been taken in compiling the references, errors or omissions cannot be excluded and the EPO disclaims all liability in this regard.

Patent documents cited in the description

- IT BO20020069 U [0004]