

(19) World Intellectual Property
Organization
International Bureau



(43) International Publication Date
10 November 2005 (10.11.2005)

PCT

(10) International Publication Number
WO 2005/106137 A2

(51) International Patent Classification⁷: E02F 3/40

(21) International Application Number:
PCT/US2005/013905

(22) International Filing Date: 22 April 2005 (22.04.2005)

(25) Filing Language: English

(26) Publication Language: English

(30) Priority Data:
60/565,250 23 April 2004 (23.04.2004) US
60/633,158 3 December 2004 (03.12.2004) US

(71) Applicant (for all designated States except US): **PLACER DOME TECHNICAL SERVICES LIMITED** [CA/CA]; Suite 1600, 1055 Dunsmuir Street, Vancouver, British Columbia V7X 1P1 (CA).

(72) Inventors; and

(75) Inventors/Applicants (for US only): **JACKSON, Eric** [CA/CA]; 311 3rd Street, New Westminster, British Columbia V3L 2R8 (CA). **FRIANT, Jim** [US/US]; 1352 SW 175th Street, Seattle, WA 98166 (US).

(74) Agents: **SWARTZ, Douglas, W.** et al.; Sheridan Ross P.C., 1560 Broadway, Suite 1200, Denver, CO 80202-5141 (US).

(81) Designated States (unless otherwise indicated, for every kind of national protection available): AE, AG, AL, AM, AT, AU, AZ, BA, BB, BG, BR, BW, BY, BZ, CA, CH, CN, CO, CR, CU, CZ, DE, DK, DM, DZ, EC, EE, EG, ES, FI, GB, GD, GE, GH, GM, HR, HU, ID, IL, IN, IS, JP, KE, KG, KM, KP, KR, KZ, LC, LK, LR, LS, LT, LU, LV, MA, MD, MG, MK, MN, MW, MX, MZ, NA, NI, NO, NZ, OM, PG, PH, PL, PT, RO, RU, SC, SD, SE, SG, SK, SL, SM, SY, TJ, TM, TN, TR, TT, TZ, UA, UG, US, UZ, VC, VN, YU, ZA, ZM, ZW.

(84) Designated States (unless otherwise indicated, for every kind of regional protection available): ARIPO (BW, GH, GM, KE, LS, MW, MZ, NA, SD, SL, SZ, TZ, UG, ZM, ZW), Eurasian (AM, AZ, BY, KG, KZ, MD, RU, TJ, TM), European (AT, BE, BG, CH, CY, CZ, DE, DK, EE, ES, FI, FR, GB, GR, HU, IE, IS, IT, LT, LU, MC, NL, PL, PT, RO, SE, SI, SK, TR), OAPI (BF, BJ, CF, CG, CI, CM, GA, GN, GQ, GW, ML, MR, NE, SN, TD, TG).

Published:

— without international search report and to be republished upon receipt of that report

For two-letter codes and other abbreviations, refer to the "Guidance Notes on Codes and Abbreviations" appearing at the beginning of each regular issue of the PCT Gazette.

(54) Title: EXCAVATION APPARATUS AND METHOD

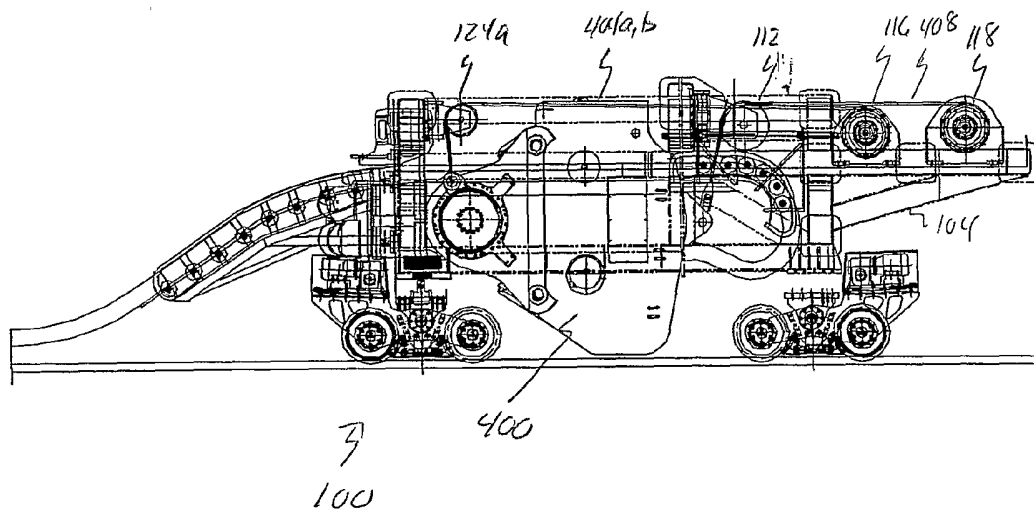

(57) Abstract: In one embodiment, an excavation method is provided that includes the steps of: (a) contacting a rotating powered cutting head (440) of an excavator (400) with an excavation face (452), wherein, at any one time, a first set of the cutting elements is in contact with the excavation face and a second set of the cutting elements is not in contact with the excavation face, the cutting head excavating the excavation face in at least a first direction; and (b) during the contacting step, using an elongated support member (404) extending from the excavator (400) to a powered device (118) to apply a force to the excavator (400) in at least the first direction to provide at least a portion of the cutting force. The powered device (118) is located at a distance from the excavator (400)

WO 2005/106137 A2

EXCAVATION APPARATUS AND METHOD

FIELD

The invention relates generally to mining valuable mineral and/or metal deposits and particularly to mining machines and methods for continuous or semi-continuous mining or such deposits.

BACKGROUND

Annually, underground mining of valuable materials is the cause of numerous injuries to and deaths of mine personnel. Governments worldwide have enacted restrictive and wide-ranging regulations to protect the safety of mine personnel. The resulting measures required to comply with the regulations have been a contributing cause of significant increases in underground mining costs. Further increases in mining costs are attributable to global increases in labor costs generally. Increases in mining costs have caused numerous low grade deposits to be uneconomic to mine and therefore caused high rates of inflation in consumer products.

To reduce mining costs and provide for increased personnel safety, a vast amount of research has been performed to develop a mining machine that can excavate materials continuously and remotely. Although success has been realized in developing machines to mine materials continuously in soft deposits, such as coal, soda ash, talc, and other sedimentary materials, there continue to be problems in developing a machine to mine materials continuously in hard deposits, such as igneous and metamorphic materials. As used herein, "soft rock" refers to *in situ* material having an unconfined compressive strength of no more than about 100 MPa (14,000 psi) and a tensile strength of no more than about 13.0 MPa (2,383 psi) while "hard rock" refers to *in situ* material having an unconfined compressive strength of at least about 150 MPa (21,750 psi) and a tensile strength of at least about 15.0 Mpa (2,750 psi). Ongoing obstacles to developing a commercially acceptable continuous mining machine for hard materials include the difficulties of balancing machine weight, size, and power consumption against the need to impart sufficient force to the cutting device to cut rock effectively while substantially minimizing dilution, maintaining machine capital and operating costs at acceptable levels, and designing a machine having a high level of operator safety.

For example, a common excavator design for excavating hard rock is an articulated excavator having a rotating boom manipulated by thrust cylinders and an unpowered cutting head having passive cutting devices, such as a box-type cutter using discs or button cutters. Such excavators typically only impart 25% of the available power into actual cutting of the rock and can be highly inefficient. Unproductive parts of the cutting cycle are substantial. For example, repositioning of the excavator requires some actuators to be extended and others retracted until a desired position is reached at which point the extended actuators are retracted and the retracted actuators extended. During excavator repositioning, no excavation occurs.

10

SUMMARY

These and other needs are addressed by the various embodiments and configurations of the present invention. The present invention is generally directed to the use of a powered cutter head and/or elongated support member (such as a cable or wire rope) in the excavation of various materials, particularly hard materials.

15

In a first embodiment of the present invention, an excavation method is provided that includes the steps:

(a) contacting a cutting head with an excavation face; and

(b) during the contacting step, using an elongated support member extending from the excavator to a powered device (e.g., a winch), located at a distance from the excavator, to apply a force to the excavator in a direction of excavation to provide at least a portion of the cutting force.

20

In a second embodiment, an excavation is provided that includes the steps:

(a) in a deposit of a material to be excavated, the deposit having a dip of at least about 35°, providing a number of intersecting excavations including first and second spaced part excavations extending in a direction of a strike of the deposit and a third excavation intersecting the first and second excavations and extending in a direction of the dip of the deposit, the first, second, and third excavations defining a block of the deposit;

25

(b) positioning the excavator in the third excavation;

(c) positioning a mobile deployment system in the first excavation, the support member extending from the mobile deployment system to the excavator; and

30

(d) contacting the cutting head with the excavation face of the block such that, at any one time, a first set of the cutting elements is in contact with the excavation face and a second set of the cutting elements is not in contact with the excavation face.

The use of a powered, rotating cutting head, particularly one having a number of
5 small discs, that cuts the advancing excavation face from the side of the cutting head can provide advantages relative to conventional excavators using box-type cutting heads. At any one time, only a portion of the discs are in contact with the rock and cutting; the remainder are out of contact with the rock and not cutting. The required cutting forces are typically drastically reduced compared to the box-type cutting head, in which all of the cutters are in
10 continuous contact with the excavation face during cutting. Moreover, an excavator using a powered cutting head to cut rock on only one side of the cutting head generally has only to push hard in one direction. An excavator using a box-type cutting head, however, generally must push hard in two directions and must travel much farther than the power cutting head. Consequently, an excavator using a powered cutting head can be much smaller than an
15 excavator using a box-type cutting head. By way of illustration, a typical box-type cutting head excavator must handle about 300,000 pounds of thrust so the bearings are quite large, thereby enlarging substantially the overall machine size. In comparison, an excavator having a powered cutting head need only handle small thrust loads so its bearings and the entire machine can be made much smaller. A powered cutting head commonly requires a cutting
20 force of less than about 50,000 lbs and more typically ranging from about 30,000 to about 40,000 lbs.

In a third embodiment, a mobile deployment frame for an excavator is provided that includes:

- (a) first and second arms disposed on either side of the frame;
- 25 (b) a central body member positioned between and connected to the first and second arms;
- (c) a number of transportation members (e.g., wheels, tracks, rubber tires, etc.) operative to permit spatial displacement of the frame; and
- (d) a first winch to manipulate the excavator.

30 The deployment frame can not only perform excavator support during excavation but also assist the excavator in self-collaring at the start of an excavation cycle. The area defined

by the first and second arms and the central body member is large enough to receive the excavator.

In a fourth embodiment, an excavator is provided that includes:

- (a) a body;
- 5 (b) actuators;
- (c) transportation members attached to the actuators;
- (d) a cutting head; and
- (e) a cutting head drive assembly.

10 The position of the cutting head relative to the body is fixed relative to a direction of travel of the excavator while excavating.

The excavator can move continuously throughout the cycle of excavating a side of the block, thereby obviating the need for repositioning the excavator at a number of discrete locations and locking the excavator into a stationary position before the excavation cycle can be commenced. Accordingly, unproductive parts of the cutting cycle are substantially
15 minimized.

The various excavators discussed above are readily adaptable to remotely controlled operation to provide increased personnel safety.

These and other advantages will be apparent from the disclosure of the invention(s) contained herein.

20 The above-described embodiments and configurations are neither complete nor exhaustive. As will be appreciated, other embodiments of the invention are possible utilizing, alone or in combination, one or more of the features set forth above or described in detail below.

As used herein, "at least one," "one or more," and "and/or" are open-ended
25 expressions that are both conjunctive and disjunctive in operation. For example, each of the expressions "at least one of A, B and C," "at least one of A, B, or C," "one or more of A, B, and C," "one or more of A, B, or C" and "A, B, and/or C" means A alone, B alone, C alone, A and B together, A and C together, B and C together, or A, B and C together.

30 BRIEF DESCRIPTION OF THE DRAWINGS

Fig. 1 is a side view of a mobile deployment frame according to a first embodiment of the present invention;

Fig. 2 is a top view of the mobile deployment frame of Fig. 1;

Fig. 3 is a front view of the mobile deployment frame of Fig. 1;

Fig. 4 is a side view of portions of the mobile deployment frame of Fig. 1 deploying an excavator according to a second embodiment of the present invention;

5 Fig. 5 is a plan view of the excavator of the second embodiment;

Fig. 6 is a front view of the excavator of Fig. 5;

Fig. 7 is a rear view of the excavator of Fig. 5;

Fig. 8 is a disassembled view of the excavator of Fig. 5;

10 Fig. 9 is a cross-sectional view of the components of the excavator taken along line 9-9 of Fig. 5;

Fig. 10 is a side view of the cutter assembly of the excavator of Fig. 5;

Fig. 11 is a bottom view of the cutter assembly of Fig. 10;

Fig. 12 is a front perspective view of the cutter assembly of Fig. 10;

Fig. 13 is a rear perspective view of the cutter assembly of Fig. 10;

15 Figs. 14A and B are, respectively, assembled and disassembled views of the cutter drive subassembly;

Fig. 15 is a side view of the stationary frame assembly of Fig. 8;

Fig. 16 is a top view of the stationary frame assembly of Fig. 8;

20 Fig. 17 is a cross sectional view of the stationary frame assembly taken along lines 17-17 of Fig. 15;

Fig. 18 is a bottom view of the stationary frame assembly of Fig. 8;

Fig. 19 is a disassembled view of the stationary frame assembly of Fig. 19;

Fig. 20 is a plan view of an excavator according to a third embodiment of the present invention;

25 Fig. 21 is a view of the excavator of Fig. 20 taken along line 21-21 of Fig. 20;

Fig. 22 is a plan view of an excavator according to a fourth embodiment of the present invention deployed in a slot;

Fig. 23 is a further view of the excavator of Fig. 22 deployed in a slot;

Fig. 24 is a plan view of the excavator of Fig. 22;

30 Fig. 25 is a front view of the excavator of Fig. 22 positioned in the slot;

Fig. 26 is a side view of the excavator of Fig. 22 positioned in the slot; and

Fig. 27 is a side view of a portion of a mobile deployment frame according to a fifth embodiment of the present invention.

DETAILED DESCRIPTION

5 The various excavators of the present invention are particularly suited for mining steeply dipping hard or high strength mineral deposits (having a dip of about 35° or more and more typically of about 45° or more) having thicknesses from several inches to several feet. Preferably, the excavations used are similar to those discussed in U.S. 6,857,706, in which the deposit is divided into a series of blocks. Each block is delineated using multiple
10 excavations, such as tunnels, headings, drifts, inclines, declines, etc., positioned above and below each block of the deposit (and typically in the plane of (and generally parallel to the strike of) the deposit) and multiple excavations, such as shafts, stopes, winzes, etc., positioned on either side of the block. As used herein, the "strike" of a deposit is the bearing of a horizontal line on the surface of the deposit, and the "dip" is the direction and angle of a
15 deposit's inclination, measured from a horizontal plane, perpendicular to the strike. Although the excavation method is described with specific reference to steeply dipping deposits, it is to be understood that the excavators described herein can be used for any mining method for excavating a deposit having any strike or dip, whether horizontally or vertically disposed, and being hard or soft rock.

20 A first excavation system will now be discussed with reference to Figs.1-9. The system includes a mobile deployment system 100 for the excavator 400. As shown in Fig. 4 (which is a plan view in the plane of the deposit), the mobile deployment system 100 is positioned in the upper excavation and is operatively connected to the excavator 400 by means of a plurality of flexible supporting members 404 and 408 (such as cables or wire
25 rope). The excavator 400 may be supported continuously or discontinuously by the members 404 and 408. For example, the excavator may be moved to various discrete positions along the face of the block 412. At each position the actuators 416a,b, 418a,b, 420a,b, and 422a,b are extended until the pad on the each of each actuator is in contact with the hanging wall 422 and footwall 424. When the cutting head 428 (which is shown in Figs. 4-5, 8, 14A and 14B
30 and 20 as being of a generic design) has been fully displaced laterally, the actuators 416a,b, 418a,b, 420a,b, and 422a,b are retracted and the excavator 400 moved by the support members 404 and 408 to a next position and the sequence repeated. When locked into

position at each discrete position, such as the position shown in Fig. 4, the cutting head 440 is rotated (around an axis of rotation that is substantially perpendicular to the direction of advance) and the cutting head moved in the manner discussed below in the direction 444 (which is substantially parallel to the excavation face 448) to excavate a segment of the block 412 and advance the advancing excavation face 452 towards the upper end of the block 412.

As will be appreciated, the cutting head 428 can be configured as a routing cutting head that not only cuts in the manner shown but also can plunge into the face 448 as part of excavation cycle to commence excavation of a next segment of the block 412.

The excavator 400 can self-collar to initiate excavation of a next segment. This capability is shown by Figs. 1-4. The mobile deployment system 100 can lift the excavator cutting head 440 to a point about the block 412, move the excavator cutting head 440 to a point adjacent to the next advancing excavation face, and lower the rotating cutting head onto the block 412 to initiate a next pass. As can be seen in Fig. 3, the mobile deployment system 440 includes an excavator support member 300 rotatably mounted on the system 100 to hold an excavator (which is depicted as a conventional excavator described in copending U.S. Patent Application Serial No. 10/688,216) in position while the next pass is initiated. Alternatively, the excavator 400 may, at the end of a pass, be lowered to the bottom face 456, moved to a starting position where the cutting head 440 is positioned adjacent to the new advancing excavation face, and the rotating cutting head 440 pushed (or pulled) into the face.

In a steeply dipping ore body, the frame 100 will typically support a substantial amount of the weight of the excavator, more typically at least about 35% of the excavator weight, and even more typically at least about 50% of the excavator weight.

The mobile deployment system 100 will now be described in more detail with reference to Figs. 1-3. The system 100 includes a support frame 104 comprised of a number of support members, the excavator support member 300 and hydraulic cylinder 304 for adjusting the orientation of the member 300, a number of wheels 108a-h (which may be rubber or inflated tires, rail mounted wheels (as shown), or caterpillar tracks) positioned on either side of the frame 104 to displace the system 100 forwards and backwards, first and second sets of sheaves 124a,b and 112, respectively, and first and second winches 116 and 118. The first winch 116 is in communication with the pair of first support members 404a,b, which respectively engage the first set of sheaves 124a,b, and are connected to the top and bottom of the front of the excavator 400. The second winch 118 is in communication with

the second support member 408, which engages the second sheave 112 and is connected to the rear of the excavator 400. As can be seen from Fig. 3, the system 100 has two arms 180 and 190 straddling the slot 194 in which the excavator 400 is positioned. The arms are connected by a central body member 194.

5 An alternative configuration of the system 100 is shown in Fig. 27. In this configuration, the second winch 118 is positioned below the first winch 116. Alternatively, the first winch 116 can be positioned below the second winch 118.

The excavator 400 will now be discussed with reference to Figs. 6-9. The excavator 400 includes a hydraulic manifold 800, a stationary frame 804 rigidly mounted on the manifold 800, and a sliding cutter assembly 808 slidably mounted in the stationary frame 804 so that the assembly 808 may be moved laterally with respect to the stationary frame 804 in the manner shown by direction 444 in Fig. 4.

The manifold 800 contains the actuators 416, 418, 420, and 422, hydraulic components needed to support the actuators and thrust cylinders in the stationary frame (discussed below), excavator electronics, and control system for remotely controlled operation. Additionally, an umbilical (not shown) extending from the system 100 to the excavator 400 is typically connected to the manifold 800. The umbilical contains conduits for providing and returning pressurized hydraulic fluid and water and conductive members for providing electrical power and telemetry. The control system can be any suitable command and control logic such as that discussed in U.S. Patent Application Serial No. 10/688,216, filed October 16, 2003, entitled "Automated Excavation Machine." The support member 408 is attached to a rear attachment assembly 450 having an attachment member 454 rotatably engaging mounting members 458a,b.

The sliding cutter assembly 808 will be described with reference to Figs.9-13 and 14A,B. The sliding cutter assembly 808 includes a frame 1000 including side members 1004a,b and top and bottom members 1008a,b, a cutter drive assembly 1012, and a plurality of rollers 1016a-l and 1020a-h rotatably mounted on the frame 1000. The rollers 1016a-l and 1020a-h rotatably contact the stationary frame 804, thereby permitting the cutter assembly 808 to move laterally and linearly forwards and backwards relative to the frame 804.

30 The cutter drive assembly 1012 will be discussed with reference to Figs. 14A and 14B. The cutter drive assembly 1012 includes a motor 1400, gearbox (not shown) (which is preferably attached to the motor through an internal spline coupling), bearings housing 1404

and bearing housing endcap 1408, radial roller bearing 1412, thrust ball bearing 1416, and drive shaft 1420. The drive shaft 1420 rigidly engages the cutting head 440 (which has a number of discrete cutting elements 1150). As shown in Figs. 14A and 14B, the drive shaft 1420 rotates the cutter head in the direction shown. Although the cutter drive assembly 1012 is depicted with a rotating cutting head, it is to be understood that a number of cutting head designs may be used, such as button cutters, disc cutters, minidisc cutters, vibrating disc cutters, undercutting disc cutters, and diamond picks, whether powered or unpowered. A powered rotating cutting head is preferred due to the lower cutting forces generally required to cut rock effectively compared to other cutter designs.

Finally, the stationary frame 804 is discussed with reference to Figs. 15-19. The frame 804 accommodates not only the thrust cylinders for the cutting process but also the cameras, lights, water and air hoses. The frame 804 includes a rear frame 1500, a top frame 1504, side frames 1508 and 1512, a bottom frame 1516, a rear skid 1520, a front skid 1524 and thrust cylinders 1528a,b. The front and rear skids contact the excavation face during excavator (re)deployment. The structural members on each of the side frames 1508 and 1512 include channels 1700 for operatively contacting and guiding the rollers 1020a-h on channel surface 1704 and rollers 1016a-l on channel surface 1708. As will be appreciated, the rollers 1016a-l and 1020a-h preload the stationary frame, eliminate play between the sliding cutter assembly and stationary frame in the axial (rotational) direction of the cutter head (the radial play between the assembly 808 and frame 804 and cutting load are substantially borne by the four rollers 1020a-h), and maintain the sliding cutter assembly 808 in a substantially constant orientation relative to the stationary frame (or providing only one degree of freedom in the plane of the page of Fig. 4 and not in a plane normal to the plane of the page or in a direction transverse to the direction 444). The frame 804 further provides the attachment points for the support members 404a,b and accommodates the thrust cylinders, which displace the cutter assembly 808 up and down in the channels in direction 444. As will be appreciated, the thrust cylinders may be positioned between the sliding cutter assembly and the bottom frame 1516 as shown or between the top frame 1504 and sliding cutter assembly. In the former case, the thrust cylinders push the cutter assembly 808 into the advancing face 452 and, in the latter case, the thrust cylinders pull the cutter assembly 808 into the advancing face 452. Alternatively, the first winch 116 and/or a further winch and support member(s) (not shown) could be attached to the sliding cutter assembly 808 to displace the assembly 808 in the

direction shown and to the desired position and provide the cutting thrust force for the cutting head 440.

The deployment frame 100 may be powered so as to be able to move in the excavation in which it is positioned and thereby move the excavator. Alternatively, the
5 deployment frame 100 may be unpowered and towed by a powered vehicle or winch and cable assembly to effect movement of the excavator.

The operation of the excavator 400 will now be described with reference to Figs. 1-7, 9-13, and 15-19. The excavator is moved, by manipulation of the support members 404a,b and 408 and movement of the deployment system 100, to a desired position, along the face of
10 the block 412, from which to initiate a next cutting sequence. During movement, the cutter drive assembly is moved to a position adjacent to the rear skid 1520. The actuators 416a,b, 418a,b, 420a,b, and 422a,b are extended until the pad on each actuator is in contact with the hanging wall 422 and footwall 424. When locked into position at each discrete position, such as the position shown in Fig. 4, the cutting head 440 is rotated around an axis of rotation that
15 is substantially perpendicular to the direction of advance and the cutting head moved in the direction 444 (which is substantially parallel to the excavation face 448) by extension of the thrust cylinders to excavate a segment of the block 412 and advance the advancing excavation face 452 towards the upper end of the block 412.

When the cutting head 428 has been fully displaced laterally, the actuators 416a,b,
20 418a,b, 420a,b, and 422a,b are retracted and the excavator 400 moved by the support members 404 and 408 to a next position and the sequence repeated. As can be seen from this description, the mobile deployment system 100 can provide both vertical thrust and position control.

Figs. 20-21 depict a further embodiment of an excavator. The excavator 2000
25 includes a body 2004, a boom 2008 rotatably mounted on the body 2004, and a cutting head 440 rotatably mounted on the boom 2008. To rotate the cutting head 440, a motor may be included in the cutting head (with the boom not rotating with the cutting head) or a motor may be located in the body 2004 with the boom and cutting head rotating together. The body 2004 includes actuators 2012a,b, 2016a,b, and 2020a,b for engaging the hanging wall 422 and footwall 424. A support member 2020 is attached to the boom 2008. The boom pivots
30 about an axis of rotation coincident with (and parallel to the longitudinal axis of) the actuators 2016a,b. Front and rear support members 2040 and 2044a,b are provided for

positioning the excavator 2000. As will be appreciated, most of the cutting force required for effective excavation is provided by the cutting head motor.

Unlike the excavator of the prior embodiment which relies on hydraulic cylinders to provide a substantial portion of the required additional cutting forces to the cutting head 440, the excavator of this embodiment relies on the front support member 2040 to provide a substantial part of the required additional cutting forces. The use of hydraulic cylinders to provide a substantial part of the required additional cutting forces can require larger excavator sizes and weights to counteract the forces imparted by the cylinders. Using one or more winches and flexible, high strength support members, in contrast, coupled with a motorized, rotating cutting head can provide substantial reductions in the excavator size and weight required for acceptable excavation rates.

In operation, the excavator 2000 is positioned in a desired position by manipulation of the mobile deployment system 100 and the first and second winches. To accommodate the unique design of the excavator 2000, the positions of the support members are reversed relative to the positions shown in Figs. 1-4. In other words, the dual support members are connected to the rear of the body while the single support member is attached to the front boom 2008. When in the desired position, the actuators 2012a,b, 2016a,b, and 2020a,b are extended and the pads locked in position on the hanging wall and footwall.

When in the desired position, the cutting head is rotated and upward force is applied to the boom by the support member 2044. The boom rotates about the forward actuators 2016a,b to form an arcuate cut 2060. The radius of the cut 2060 is, of course, the length of the boom and cutting head 440 measured from the axis of rotation of the boom. When the cutting head is passed through the excavation face as shown by the dotted lines, the actuators of the excavator are retracted and disengaged from the hanging wall and footwall and the excavator moved using the rear support members 2044a,b, to a next desired position to initiate a next cutting sequence.

As will be appreciated, the orientation of the "cut" or excavation pass by the cutting head can be controlled or "steered" by differentially extending the various actuators in the body. The plane of the excavation pass is generally parallel to the plane of the upper and lower plates 2050a,b of the body 2004 because the boom 2008 has freedom of movement only in the plane of the page of Fig. 20 and not in a plane perpendicular to the plane of the

page. By properly extending the actuators to manipulate the plates to a desired three-dimensional orientation, the orientation of the cut can be manipulated at the same time.

A further embodiment of an excavator is shown in Figs. 22-26.

Referring to Figs. 24-26, the excavator 2400 includes a cutting head 440, a number of
5 tracks 2404a-h, actuators 2408a-h, and a body member 2412 housing the cutter drive
assembly 1012. The actuators 2408a-h extend a corresponding track 2402a-h to contact the
hanging wall 422 or footwall 424 to movably maintain a desired position and orientation of
the excavator 2400 relative to the excavation face 2200. The cutter drive assembly 1012 is
rigidly mounted on the body member 2412 so that the assembly 1012 does not move laterally
10 with respect to the body member. The cutting thrust force is provided by the support member
408 which is slowly retracted by winch 118 as the excavator 2400 progressively excavates
and advances the advanced excavation face 2204. Even though the actuators are extended to
cause contact of the tracks with the excavation walls, the tracks permit the excavator 2400 to
move forward towards the mobile deployment system 100 as the support member 408 is
15 spooled onto the winch 118. The advantage of this excavator over the excavators described
above is that the excavator can move continuously throughout the cycle of excavating a pass
of the block 412 while the excavators above must be repositioned discontinuously at a
number of discrete locations along the excavation face and locked into a stationary position
before the excavation cycle can be commenced. At the conclusion of a complete excavation
20 pass of the face 220, the cutting head 440 of the excavator 2400 is lowered to a position
below the lower block surface 2208 prior to the initiation of a next excavation pass.

A number of variations and modifications of the invention can be used. It would be possible to provide for some features of the invention without providing others.

For example in one alternative embodiment, the tracks 2404a-h are steerable (or
25 rotatable in the plane of the page of Fig. 24) relative to the body member. This permits the
excavator to be steered as it is being pulled. Typically, a linkage connects to opposing pairs
of tracks, such as between tracks 2404a,e, 2404b,f, 2404c,g, and 2404d,h so that the pairs of
tracks rotate in unison (or simultaneously to the same degree). Motors and/or hydraulic
cylinders can be used to provide the motive force to steer the tracks.

30 In another embodiment, the powered winch is replaced by a powered vehicle that
tows the excavator during excavation. This embodiment is particularly attractive for
horizontal or relatively flat-lying deposits.

In another embodiment, the thrust force is provided collectively both internally, such as by one or more thrust cylinders, and externally, such as by a support member and winch.

The present invention, in various embodiments, includes components, methods, processes, systems and/or apparatus substantially as depicted and described herein, including various embodiments, subcombinations, and subsets thereof. Those of skill in the art will understand how to make and use the present invention after understanding the present disclosure. The present invention, in various embodiments, includes providing devices and processes in the absence of items not depicted and/or described herein or in various embodiments hereof, including in the absence of such items as may have been used in previous devices or processes, e.g., for improving performance, achieving ease and/or reducing cost of implementation.

The foregoing discussion of the invention has been presented for purposes of illustration and description. The foregoing is not intended to limit the invention to the form or forms disclosed herein. In the foregoing Detailed Description for example, various features of the invention are grouped together in one or more embodiments for the purpose of streamlining the disclosure. This method of disclosure is not to be interpreted as reflecting an intention that the claimed invention requires more features than are expressly recited in each claim. Rather, as the following claims reflect, inventive aspects lie in less than all features of a single foregoing disclosed embodiment. Thus, the following claims are hereby incorporated into this Detailed Description, with each claim standing on its own as a separate preferred embodiment of the invention.

Moreover, though the description of the invention has included description of one or more embodiments and certain variations and modifications, other variations and modifications are within the scope of the invention, e.g., as may be within the skill and knowledge of those in the art, after understanding the present disclosure. It is intended to obtain rights which include alternative embodiments to the extent permitted, including alternate, interchangeable and/or equivalent structures, functions, ranges or steps to those claimed, whether or not such alternate, interchangeable and/or equivalent structures, functions, ranges or steps are disclosed herein, and without intending to publicly dedicate any patentable subject matter.

What is claimed is:

1. An excavation method, comprising:
providing an excavator, the excavator having a powered, rotating cutting head, the cutting head having a plurality of cutting elements;
5 contacting the cutting head with a hard rock excavation face, wherein, at any one time, a first set of the cutting elements is in contact with the excavation face and a second set of the cutting elements is not in contact with the excavation face and wherein, in the contacting step, the cutting head excavates the excavation face in at least a first direction; and
during the contacting step, using an elongated support member extending from the
10 excavator to a powered device to apply a force to the excavator in at least the first direction to provide at least a portion of the cutting force, wherein the powered device is located at a distance from the excavator.
2. The excavation method of claim 1, wherein the rotating cutting head has an axis of rotation and wherein the axis of rotation is normal to the first direction, wherein the
15 cutting head is mounted on a boom, and wherein the boom is nonrotatably mounted on the excavator body.
3. The excavation method of claim 1, wherein the excavation face exposes an ore body, wherein the ore body has a dip of about 35° or more, wherein a deployment frame is positioned in a first excavation, wherein the excavator is positioned in a second excavation
20 transverse to the first excavation, wherein the first excavation generally extends in a direction of a strike of the ore body, wherein the second excavation generally extends in a direction of the dip of the ore body, and wherein the powered device is positioned on the frame.
4. The excavation method of claim 1, wherein the powered device is a winch and wherein the support member is one of a wire rope and cable.
- 25 5. The excavation method of claim 3, wherein the frame comprises an excavator receiving member rotatably disposed on the frame for collaring the excavator in a slot exposing the ore body and wherein the support member supports at about 35% of the weight of the excavator during the contacting step.
6. The excavation method of claim 1, wherein a portion of the excavator is
30 stationary during the contacting step and wherein the portion of the excavator is anchored in position using a plurality of hydraulic actuators.

7. The excavation method of claim 1, wherein the excavator comprises a boom engaging the cutting head and rotatably engaging a body of the excavator.

8. The excavation method of claim 1, wherein at least most of the body of the excavator is positioned to the side of the cutting head during the contacting step and wherein
5 at least most of the body of the excavator is not positioned behind the cutting head during the contacting step.

9. The excavation method of claim 1, wherein the excavator comprises a sliding cutter assembly, the sliding cutter assembly receiving a cutter drive assembly and the cutting head, and a body and wherein the sliding cutter assembly moves in the first direction during
10 the contacting step while the body remains stationary.

10. In a deposit of a material to be excavated, the deposit having a dip of at least about 35°, the deposit being accessible by a plurality of intersecting excavations including at least first and second spaced part excavations extending at least substantially in a direction of a strike of the deposit and at least a third excavation intersecting the first and second
15 excavations and extending at least substantially in a direction of the dip of the deposit, the first, second, and third excavations defining a block of the deposit, a method, comprising:

positioning an excavator in the third excavation, the excavator having a powered, rotating cutting head, the cutting head having a plurality of cutting elements;

positioning a mobile deployment system in the first excavation, at least one support
20 member extending from the mobile deployment system to the excavator; and

contacting the cutting head with an excavation face of the block, wherein, at any one time, a first set of the cutting elements is in contact with the excavation face and a second set of the cutting elements is not in contact with the excavation face.

11. The excavation method of claim 10, wherein, in the contacting step, the
25 cutting head excavates the excavation face in at least a first direction; and further comprising:

during the contacting step, using an elongated support member extending from the excavator to a powered device to apply a force to the excavator in at least the first direction to provide at least a portion of the cutting force, wherein the powered device is located at a distance from the excavator, wherein the powered device is positioned on the frame.

12. The excavation method of claim 11, wherein the powered device is a winch
30 and wherein the support member is one of a wire rope and cable.

13. The excavation method of claim 10, wherein the frame comprises an excavator receiving member rotatably disposed on the frame for collaring the excavator in a slot exposing the ore body and wherein the support member supports at about 35% of the weight of the excavator during the contacting step.

5 14. The excavation method of claim 10, wherein a portion of the excavator is stationary during the contacting step and wherein the portion of the excavator is anchored in position using a plurality of hydraulic actuators.

15. The excavation method of claim 10, wherein the excavator comprises a boom engaging the cutting head and rotatably engaging a body of the excavator.

10 16. The excavation method of claim 10, wherein at least most of the body of the excavator is positioned to the side of the cutting head during the contacting step and wherein at least most of the body of the excavator is not positioned behind the cutting head during the contacting step.

15 17. The excavation method of claim 10, wherein the excavator comprises a sliding cutter assembly, the sliding cutter assembly receiving a cutter drive assembly and the cutting head, and a body and wherein the sliding cutter assembly moves in the first direction during the contacting step while the body remains stationary.

18. An excavator, comprising:
a body;
20 a plurality of actuators;
a plurality of transportation members, at least one actuator being in contact with a transportation member;
a cutting head; and
a cutting head drive assembly, wherein the position of the cutting head relative to the
25 body is fixed relative to a direction of travel of the excavator during excavating.

19. The excavator of claim 18, wherein a first set of transportation members are positioned above the body and a second set of transportation members are positioned below the body, wherein the transportation members are at least one of a wheel, a track, and a tire, and wherein the first set of transportation members are configured to contact a hanging wall
30 of an excavation and the second set of transportation members are configured to contact a footwall of the excavation.

20. A deployment frame for an excavator, comprising:

first and second arms disposed on either side of the frame;

a central body member positioned between and connected to the first and second arms;

5 a plurality of transportation members operative to permit spatial displacement of the frame, a first set of the plurality of transportation members being in operative engagement with the first arm and a second set of the plurality of transportation members being in operative engagement with the second arm; and

at least a first winch, wherein an area defined by the first and second arms and the central body member is configured to receive the excavator.

10 21. The deployment frame of claim 20, further comprising:

an excavator receiving member rotatably disposed on the frame and positioned in the area between the first and second arms for receiving and supporting the excavator.

22. The deployment frame of claim 20, wherein the excavator is positioned in a slot and wherein the first and second arms are positioned on either side of the slot.

15

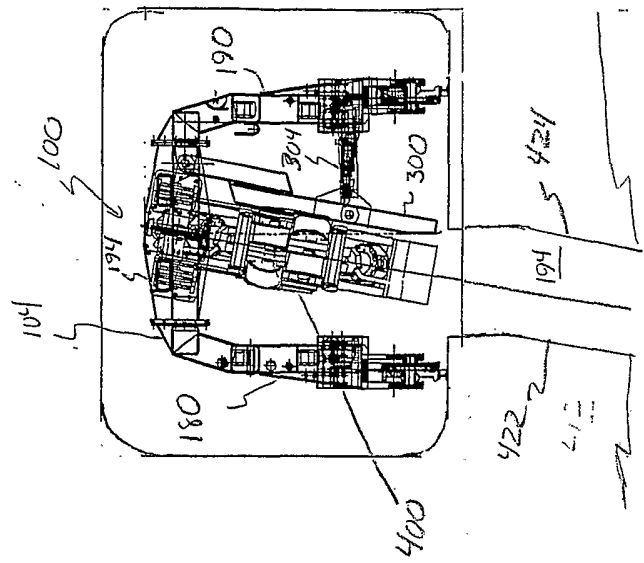
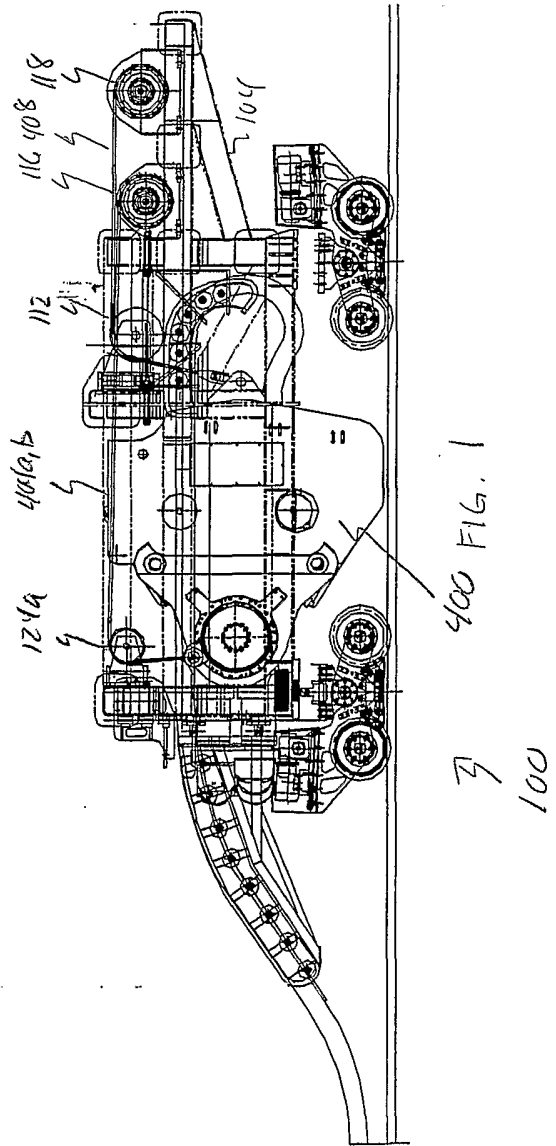
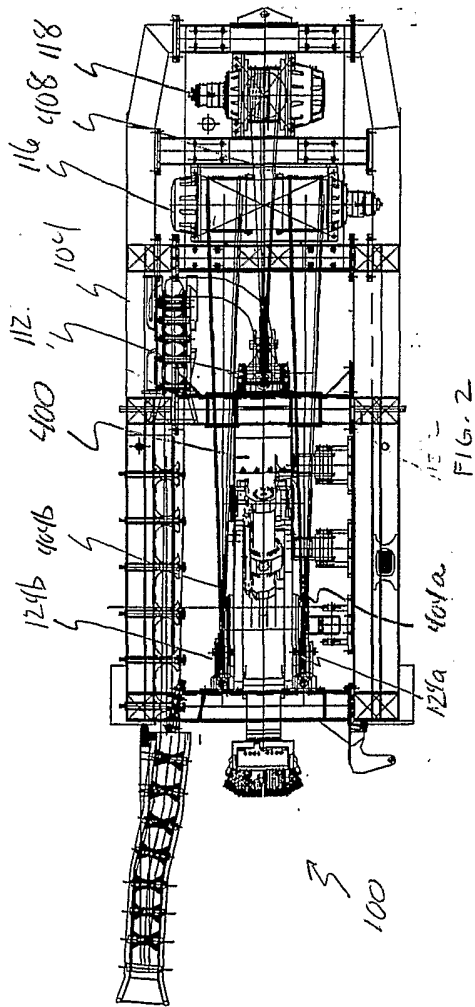

FIG. 3

FIG. 2

FIG. 1

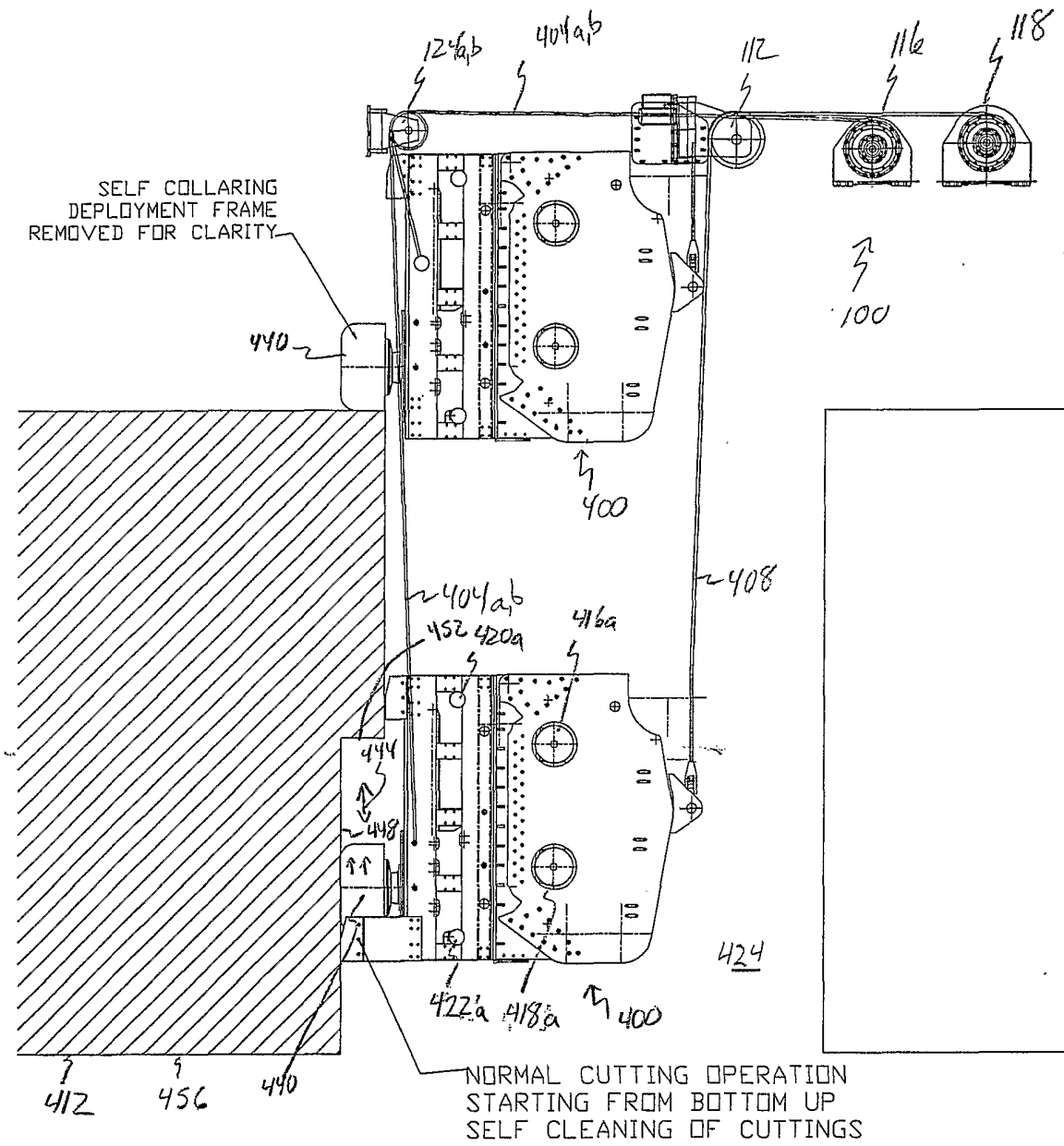
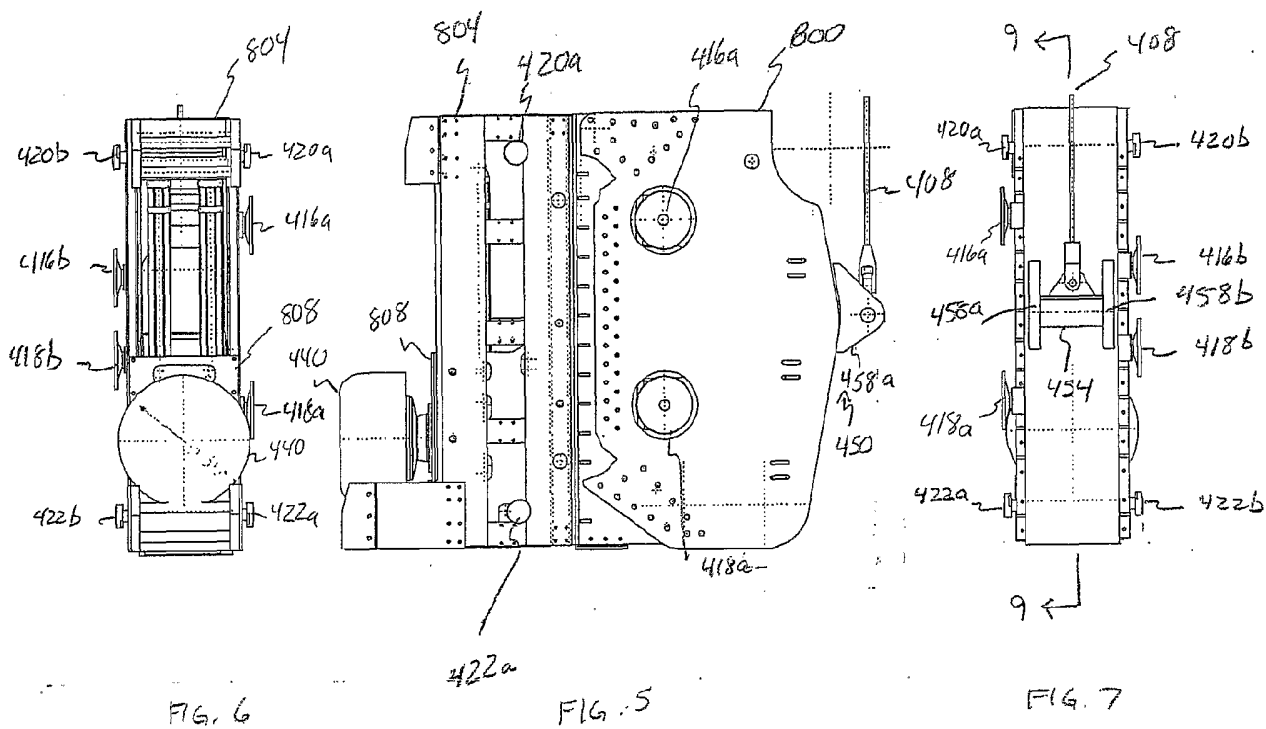

FIG. 4



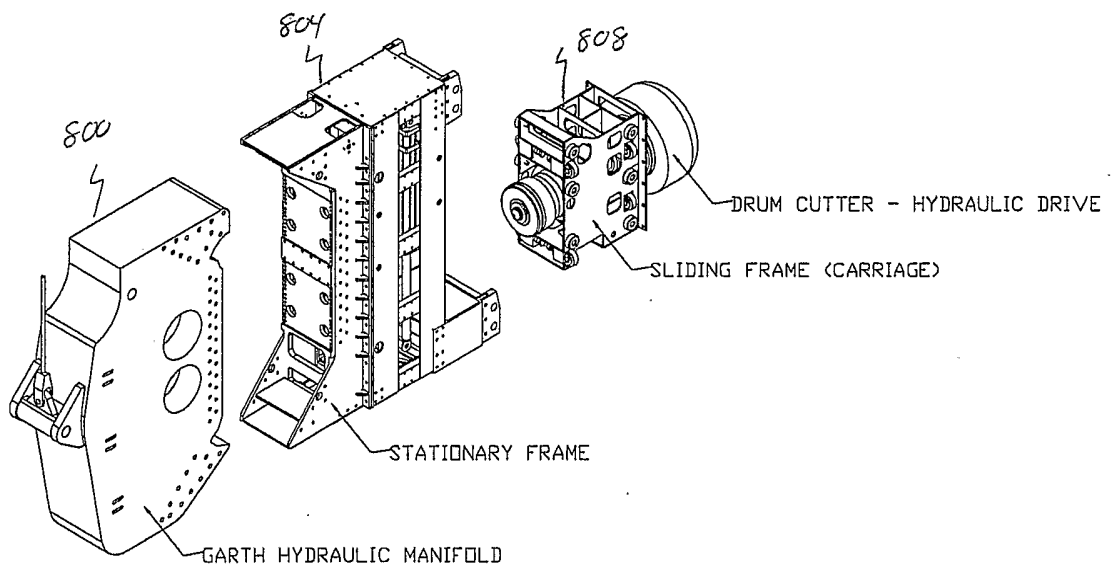

FIG. 8

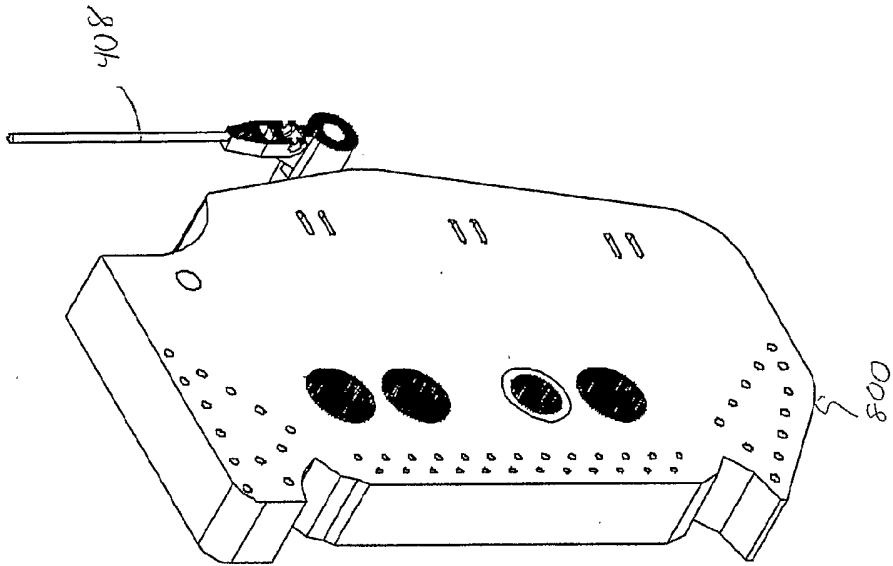
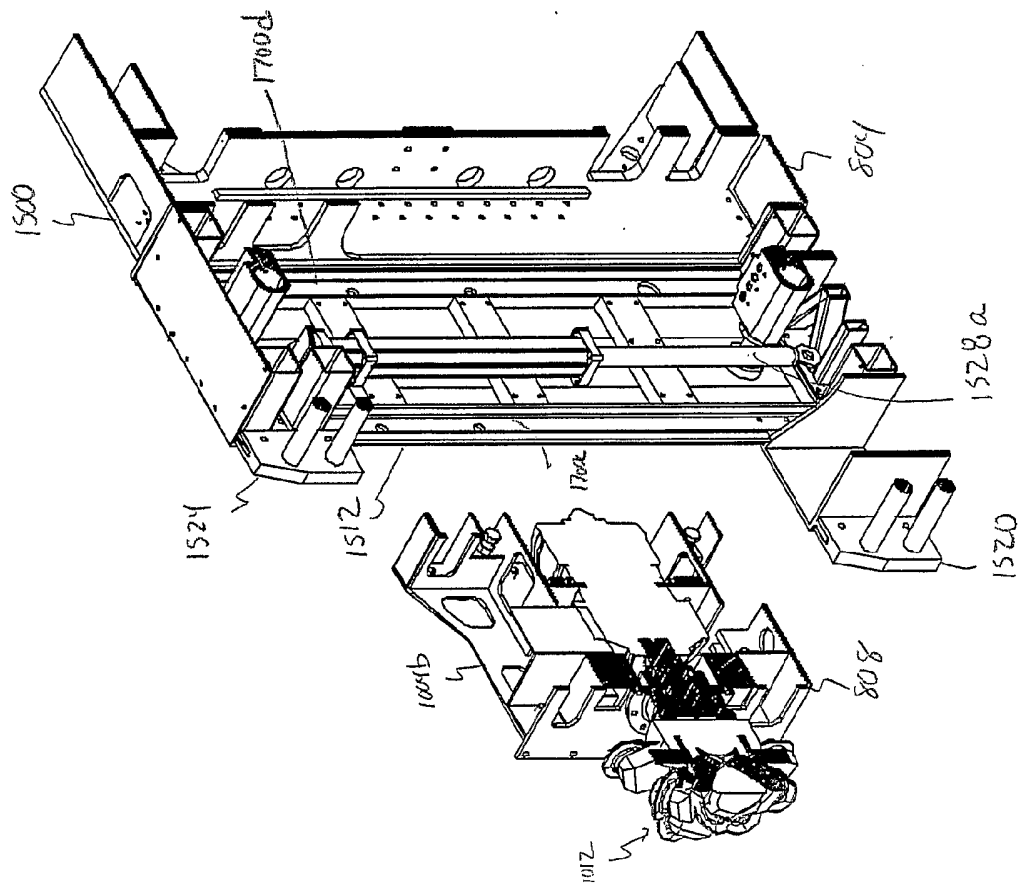
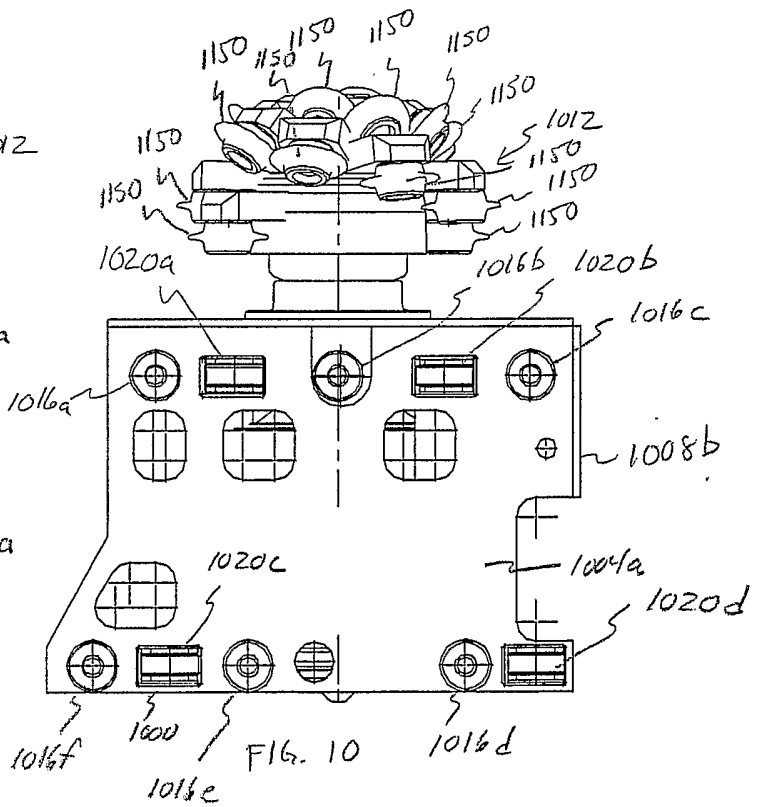
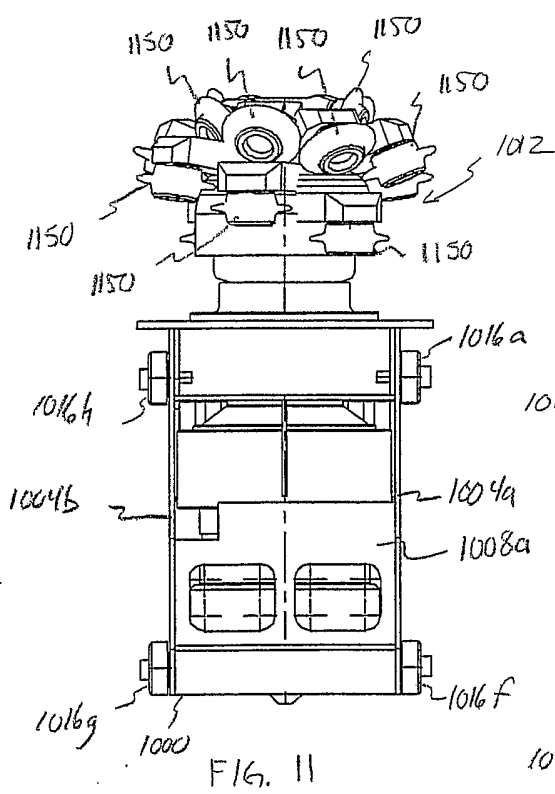

FIG. 9





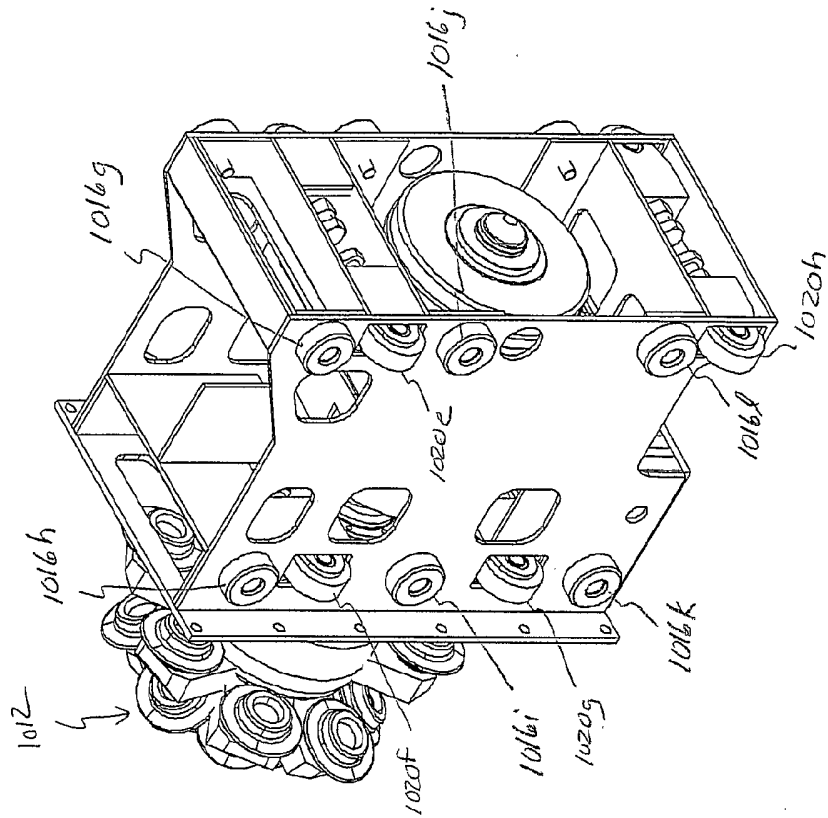

FIG. 13

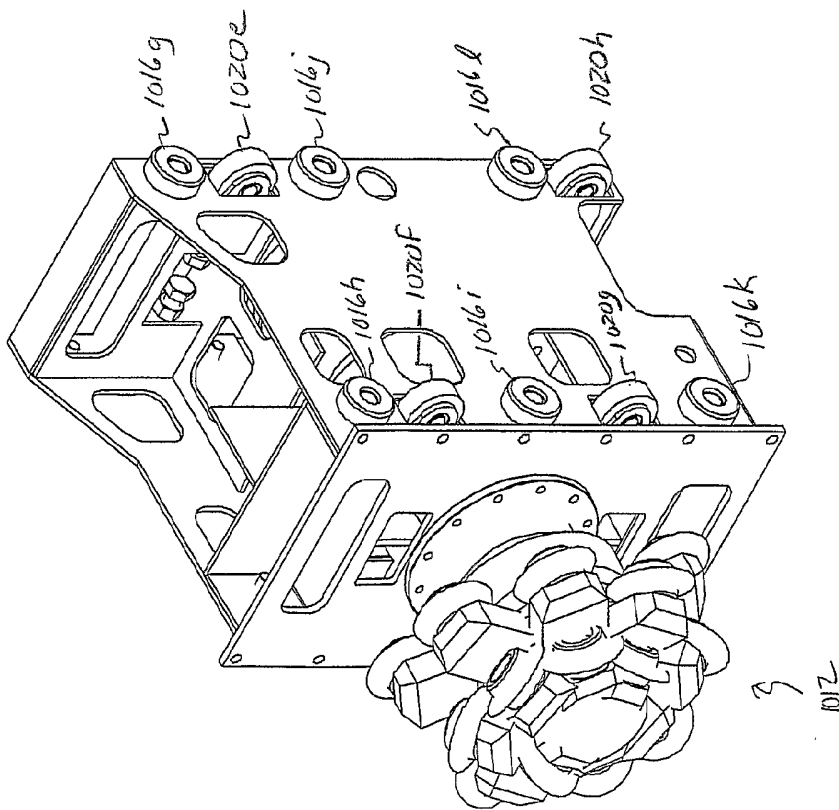
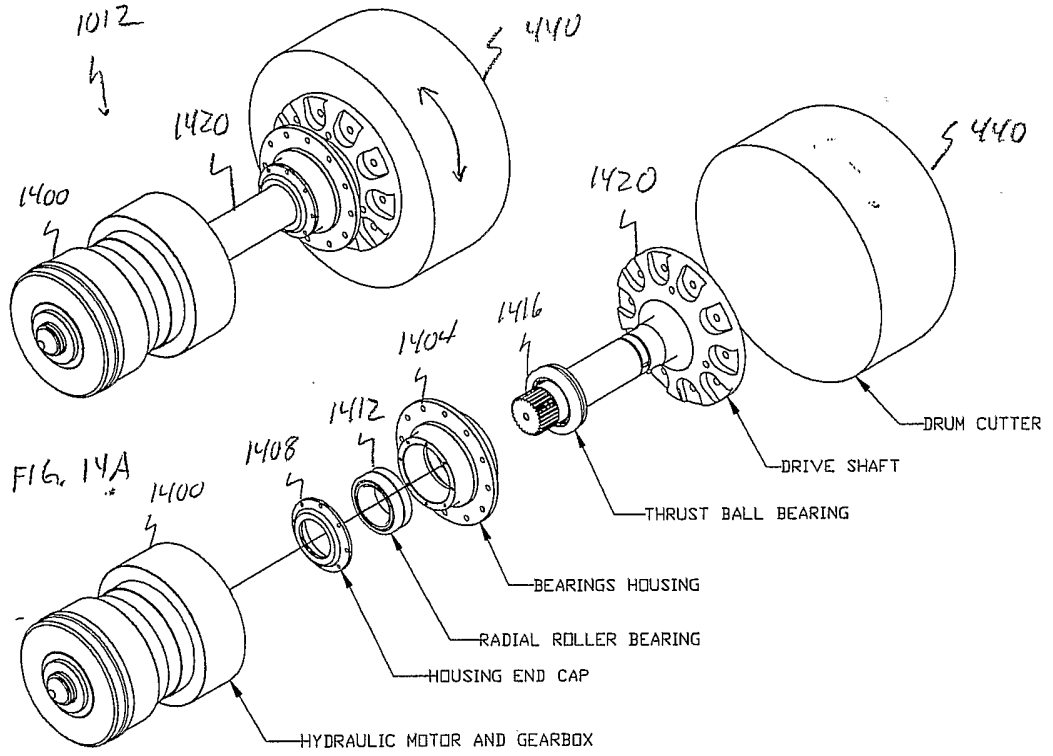
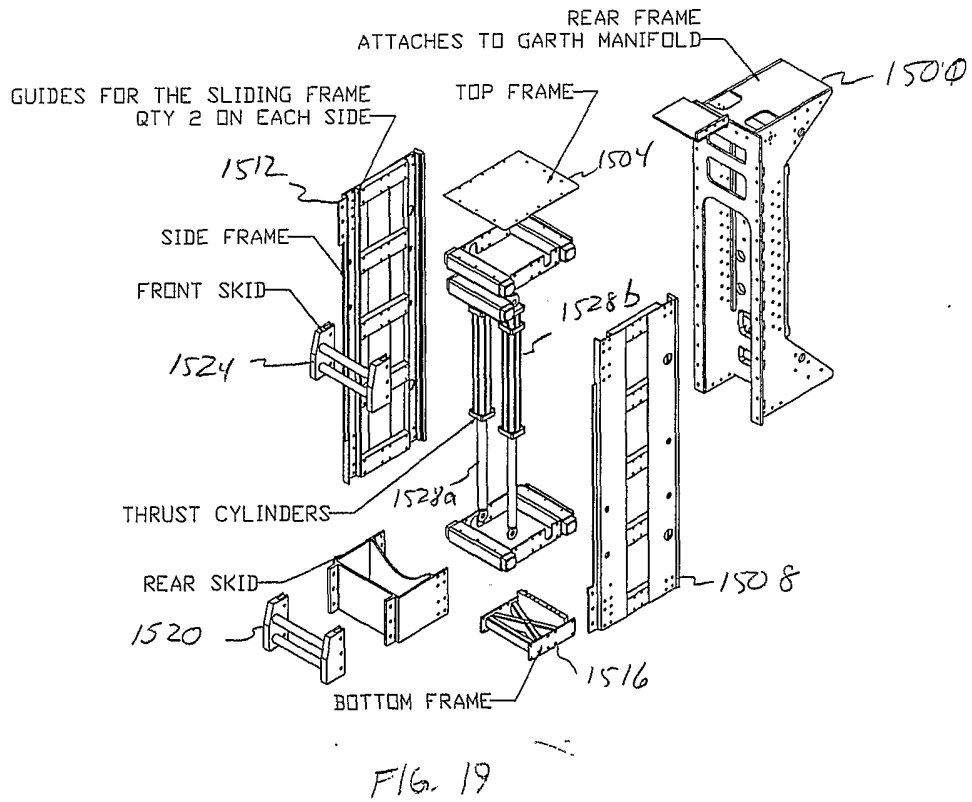
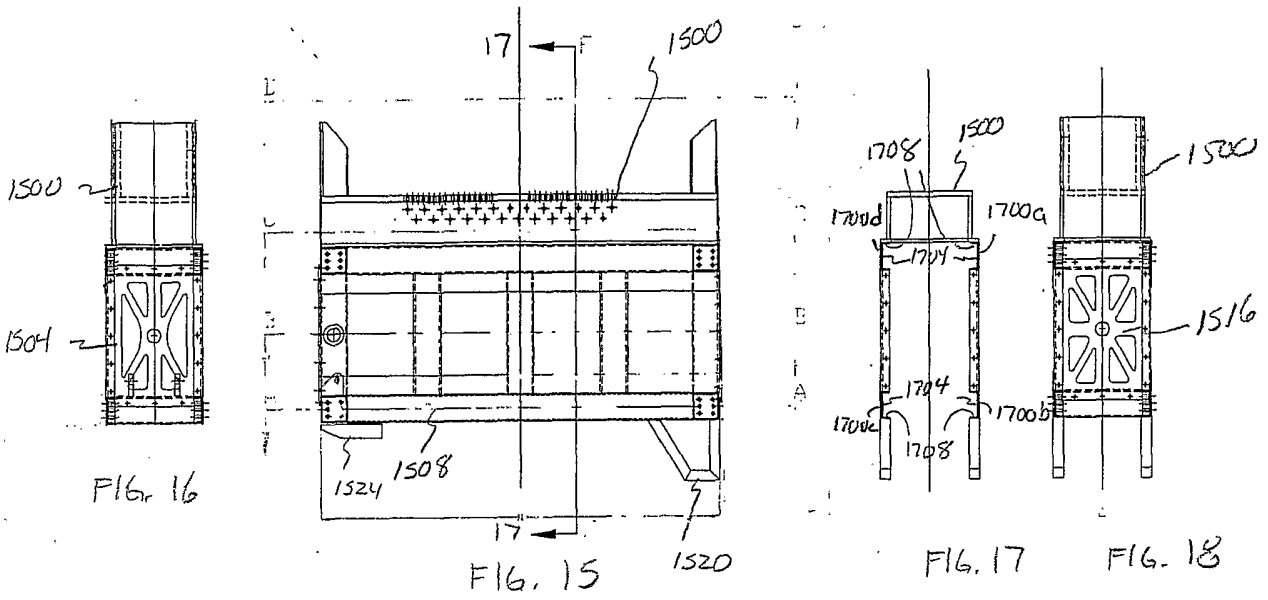

FIG. 12



1012

FIG. 14B



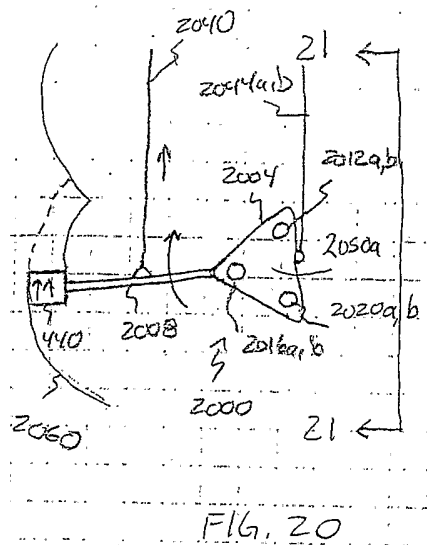

FIG. 20

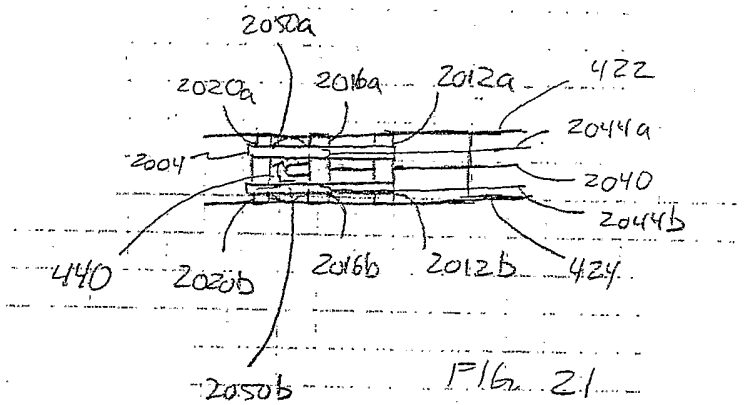

FIG. 21

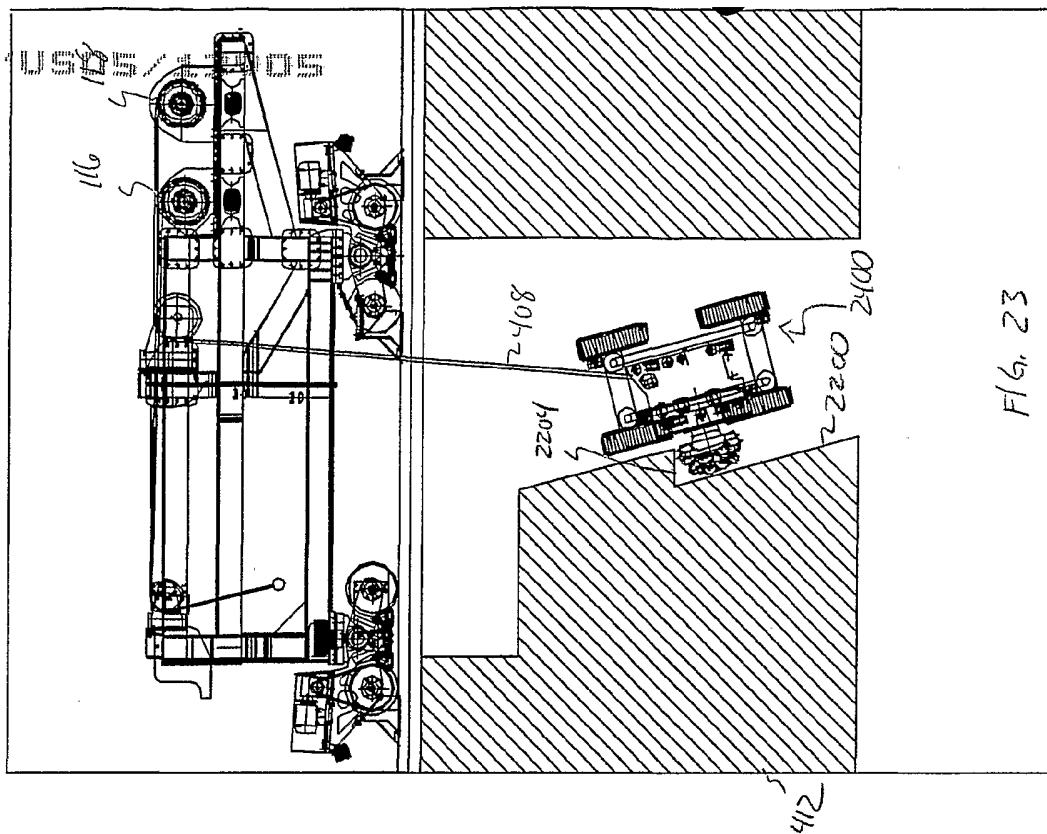

Fig. 23

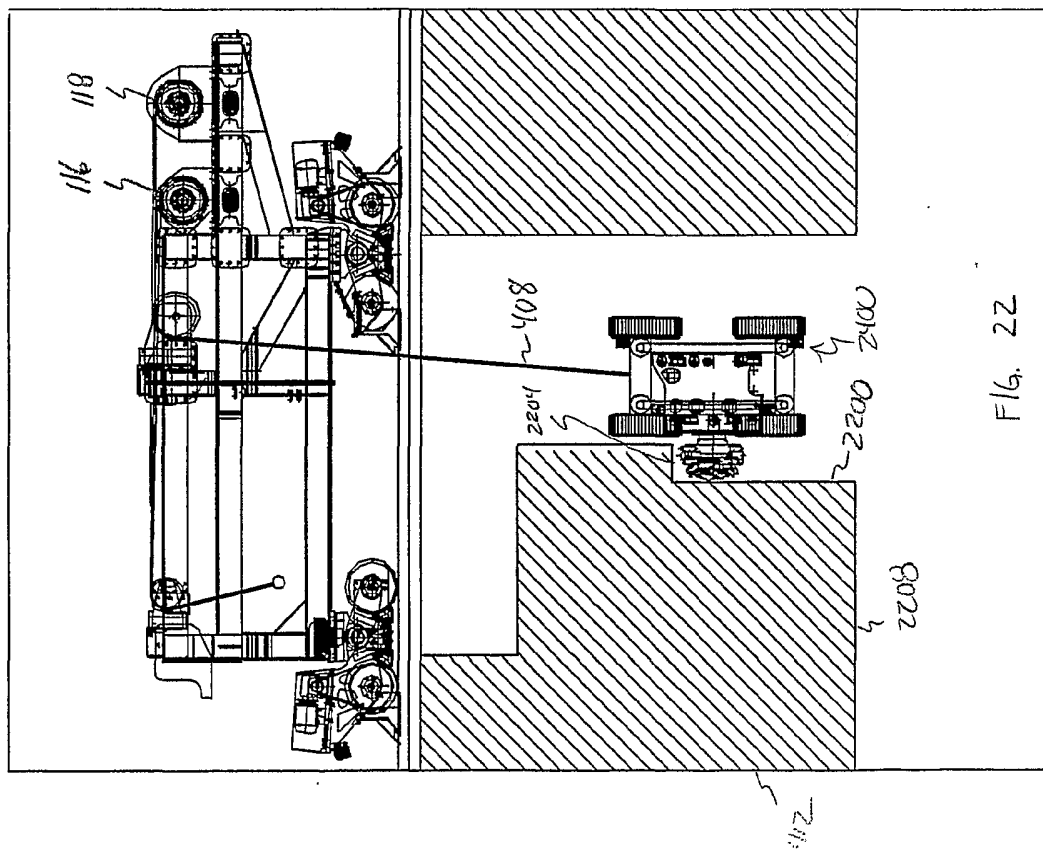
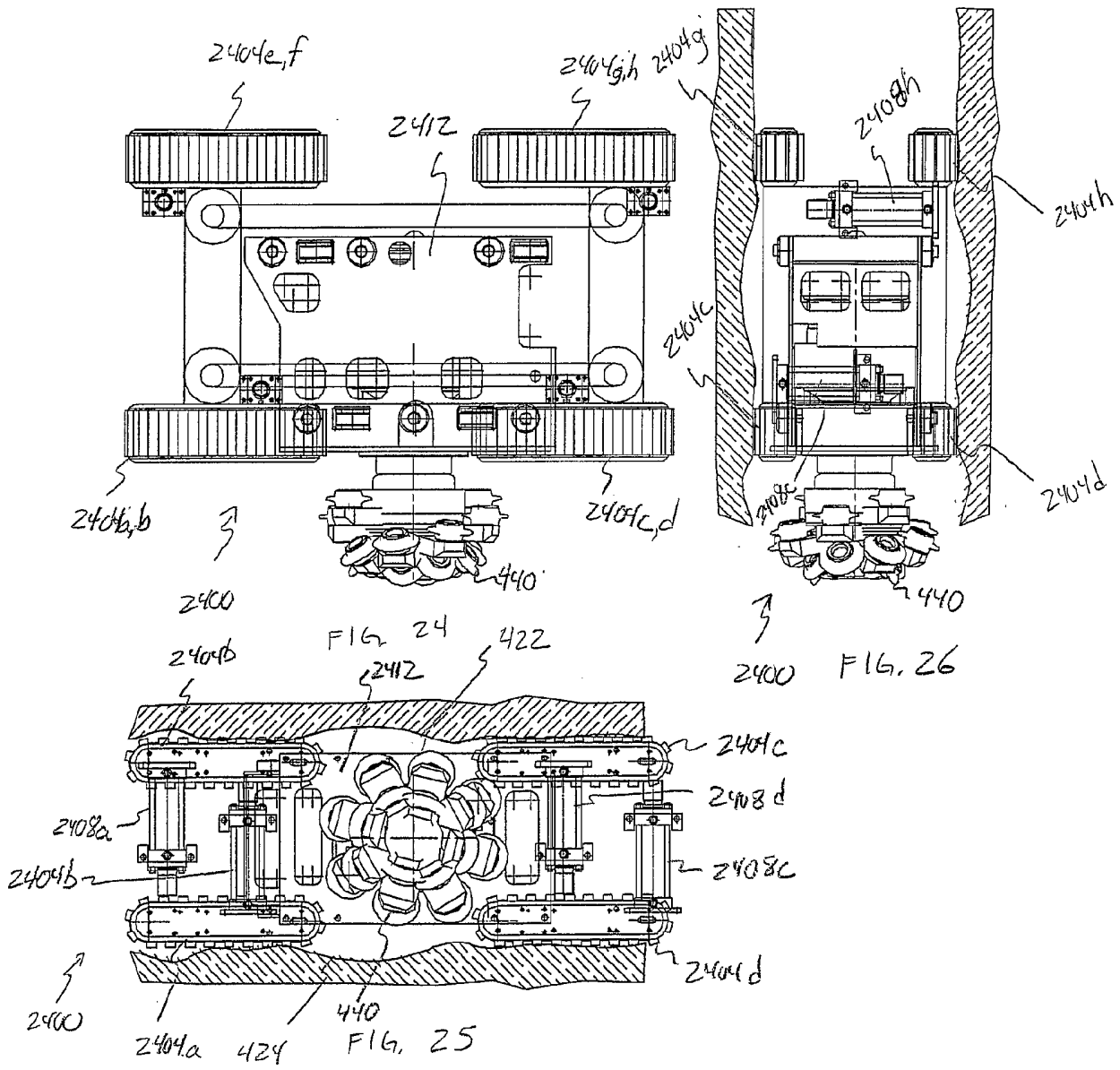

Fig. 22



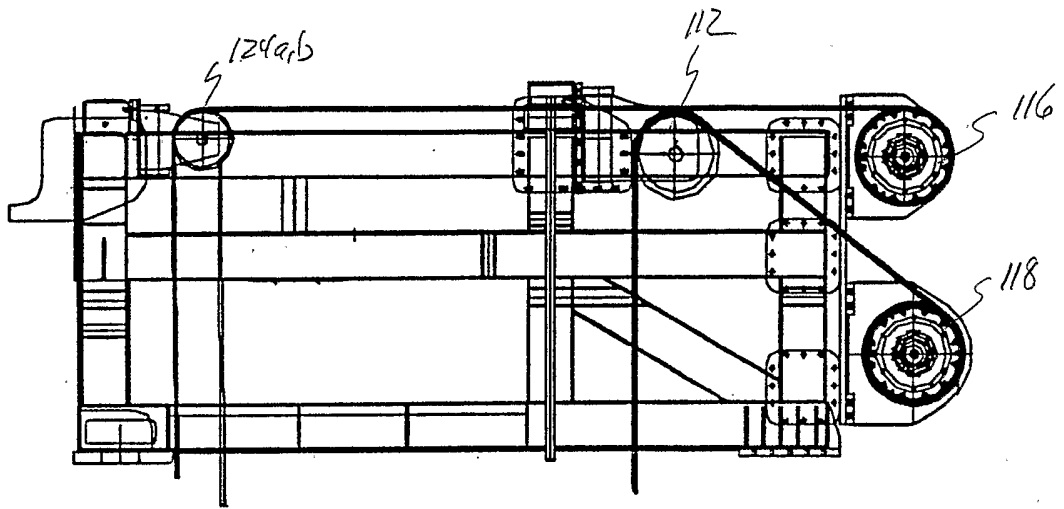

FIG. 27