

C. H. MASON.
Sewing-Machines.

No. 157,017.

Patented Nov. 17, 1874.

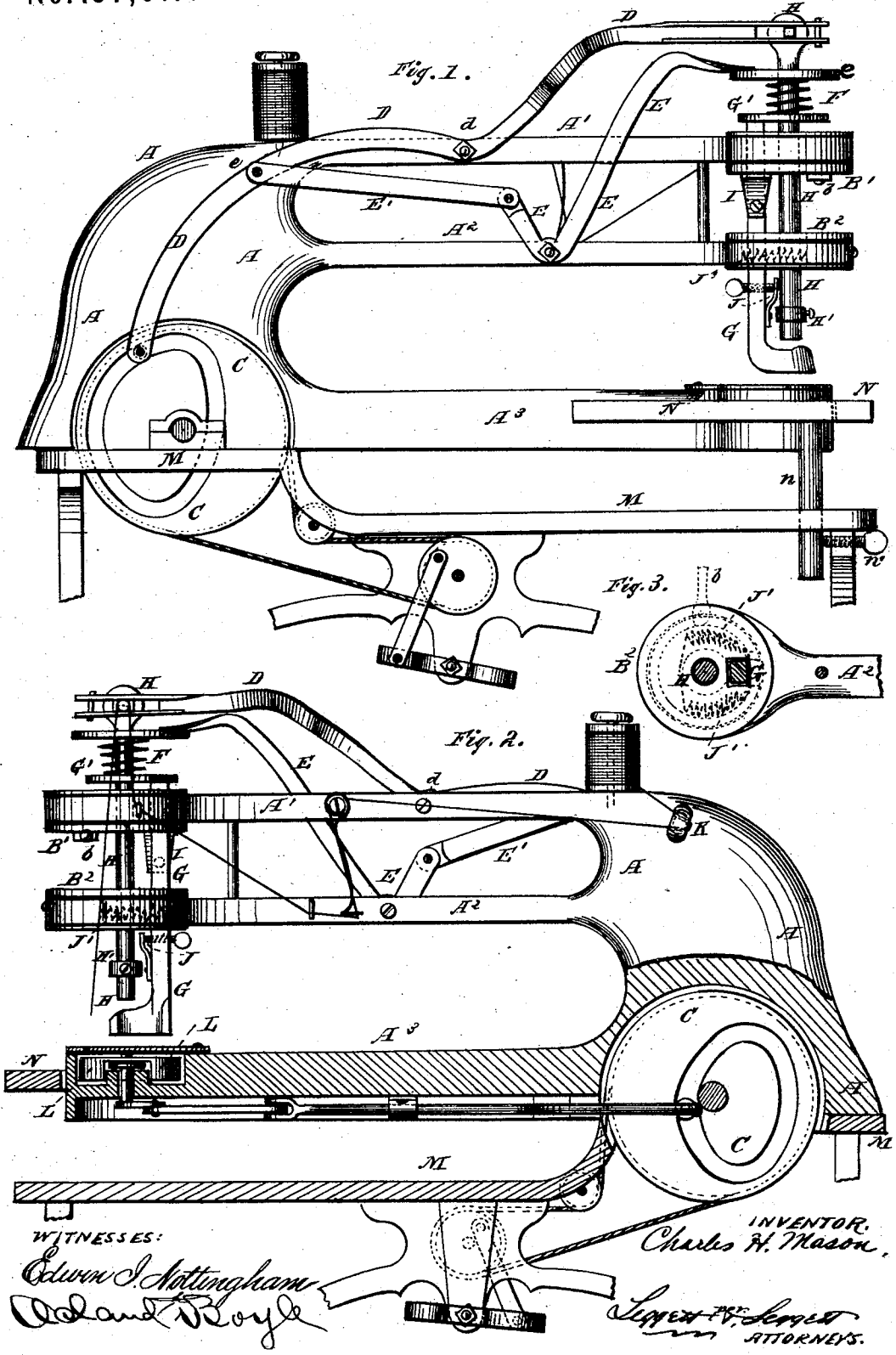

UNITED STATES PATENT OFFICE.

CHARLES H. MASON, OF SANDUSKY, OHIO, ASSIGNOR OF ONE-HALF HIS
RIGHT TO LAWRENCE CABLE.

IMPROVEMENT IN SEWING-MACHINES.

Specification forming part of Letters Patent No. **157,017**, dated November 17, 1874; application filed
August 28, 1874.

To all whom it may concern:

Be it known that I, CHARLES H. MASON, of Sandusky, in the county of Erie and State of Ohio, have invented certain new and useful Improvements in Machine for Sewing Leather; and I do hereby declare the following to be a full, clear, and exact description of the invention, such as will enable others skilled in the art to which it pertains to make and use it, reference being had to the accompanying drawings, which form part of this specification.

My invention relates to a machine for sewing leather; and consists in the combination of devices and appliances, as hereinafter set forth and claimed.

In the drawings, Figure 1 is a side elevation of my invention; Fig. 2, a simple elevation taken from the opposite side. Fig. 3 is a separate view of the end of the central arm, showing one of the perforated revolving plates.

A is a frame-work, made in a single casting, and provided with three arms, A¹, A², and A³. In the ends of the arms A¹ and A² are revolving circular plates B¹ and B², through which pass the needle-bar and the presser-foot bar. C is a wheel, provided with a cam upon each of its sides: that upon the outside operates the needle-bar and presser-foot bar; that upon the inside operates the shuttle. D is a lever, operated by the cam-wheel C. It is hinged to an upper arm, A¹, at *d*, and its other end is connected to the top of the needle-bar. At *e* on the arm D is hinged a link-bar, E', which is connected to the short arm of the lever E, which, in turn, is pivoted to the arm A² of the frame. The long arm of the lever E presses a spring, F, which spring presses upon the top of a plate, G', which encircles the needle-bar loosely, and is attached rigidly to the top of the presser-foot bar. It will thus be seen that as the cam-wheel C is revolving, the levers D and E are operated, and they in turn operate the presser-foot G and the needle-bar H. The presser-foot bar, it will be observed, has less travel than the end of the lever E. This causes the lever E to compress the spring F, thereby holding the presser-foot with a tension against the surface of the leather. I is

a spring that withdraws the presser-foot from the leather as the lever E recedes. By the arrangement of levers D and E and link E' the presser-foot G is forced down against the leather before the needle-bar comes down, and it is held down until after the needle-bar recedes. The presser-foot has two springs, between which the needle-bar passes. They serve to press the presser-foot against the seam before the needle enters. J is a spring and set-screw. J' is a spring that presses the presser-foot toward the needle-bar. The presser-foot being upon the leather and the needle-bar receding, the collar, or its equivalent, H', upon the needle-bar strikes against the spring J, thereby pressing aside the presser-foot and feeding the leather forward one stitch in the direction it happens to be from the needle-bar. The circular plates B¹ and B², which encircle the needle-bar, serve at the same time to hold the presser-foot bar in any desired place. A handle, *b*, is attached to one of the said disks, by which the disks are revolved, and in revolving they carry the presser-foot bar with them, giving it any desired position relative to the needle-bar, and as the machine always feeds from the needle-bar toward the presser-foot bar it is evident that the machine may be made to sew in any direction by simply operating the handle *b*. K is a thumb-screw tension, provided with two holes, through which the thread passes; but the tension device for the thread I do not claim to be of my invention. L is the shuttle-driver in the end of the arm A³, operated by an arm that is geared to the inside cam of the wheel C. M is the stand, beveled away from the rear to the front, so as to leave free space below the arm A³ of the frame A, so as to admit of a shoe or other article being slipped upon the arm A³. N is a table, arranged to be raised or lowered and adjusted to any desired position by a standard-rod, *n*, and set-screw *n'*.

This machine is provided with a suitable treadle, a walking-treadle being shown in the drawings, which treadle is suitably geared to the cam-wheel C. The end of the lever D is attached to the top of the needle-bar loosely,

so that while the bar D moves in the arc of a circle around the point *d*, the needle-bar will move directly up and down.

What I claim as new, and desire to secure by Letters Patent, is—

1. In combination with the needle-bar and presser-foot, the operating-levers D, operated by the cam-wheel C, pivoted to the upper arm A¹ at *d*, and bell-crank lever E, constructed or formed at its front end into the disk *e*, pivoted to the arm A², and connected to the lever D by a link-bar, E', all constructed and arranged as described, whereby the needle-bar and presser-foot are both operated and kept in their relative positions by the single cam C and lever D.

2. The combination and arrangement of frame-work A A¹ A² A³, disks B¹ B², operating compound levers D E, link E', presser-foot G G', needle-bar H, springs F I J, and single cam C, all constructed, arranged, and operating substantially as and for the purposes described.

In testimony that I claim the foregoing I have hereunto set my hand this 22d day of August, 1874.

CHARLES HENRY MASON.

Witnesses:

BENJAMIN F. LEE,
WILLIAM S. MCALPINE.