

(19)



Europäisches Patentamt
European Patent Office
Office européen des brevets



(11)

EP 0 609 966 B1

(12)

EUROPEAN PATENT SPECIFICATION

(45) Date of publication and mention
of the grant of the patent:
19.03.1997 Bulletin 1997/12

(51) Int Cl.⁶: **G03G 15/16**, G03G 15/01

(21) Application number: **94200966.3**

(22) Date of filing: **13.12.1990**

(54) Imaging system with intermediate transfer member

Bilderzeugungssystem mit Zwischenübertragungselement

Système de formation d'images avec un élément de transfert intermédiaire

(84) Designated Contracting States:
DE FR GB IT

(43) Date of publication of application:
10.08.1994 Bulletin 1994/32

(60) Divisional application: **96202488.1**

(62) Application number of earlier application in
accordance with Art. 76 EPC: **91901324.3**

(73) Proprietor: **INDIGO N.V.**
6229 GA Maastricht (NL)

(72) Inventors:
• **Lior, Ishaiau**
Ness Ziona 70400 (IL)

- **Landa, Benzion**
Edmonton, Alberta T5K 1Y8 (CA)
- **Lavon, Amiran**
Bat Yam 59576 (IL)
- **Pinhas, Hanna**
Holon 58331 (IL)

(74) Representative: **de Bruijn, Leendert C. et al**
Nederlandsch Octrooibureau
P.O. Box 29720
2502 LS Den Haag (NL)

(56) References cited:
WO-A-90/04216 **US-A- 4 690 539**

- **PATENT ABSTRACTS OF JAPAN vol. 8, no. 254**
(P-315) (1691) 21 November 1984 & JP-A-59 125
766.

EP 0 609 966 B1

Note: Within nine months from the publication of the mention of the grant of the European patent, any person may give notice to the European Patent Office of opposition to the European patent granted. Notice of opposition shall be filed in a written reasoned statement. It shall not be deemed to have been filed until the opposition fee has been paid. (Art. 99(1) European Patent Convention).

Description

FIELD OF THE INVENTION

The present invention relates to image transfer techniques and apparatus for use in electrophotography.

BACKGROUND OF THE INVENTION

Various prior publications deal with the transfer of single and multiple powder and liquid toner images from a photoreceptor on which they are formed to an intermediate transfer member for subsequent transfer to a final substrate.

U. S. Patent 3,838,919 to Takahashi describes a powder toner system in which color toner images are sequentially formed on an image forming member, individually transferred to an intermediate transfer member and transferred at one time to a recording member.

U. S. Patent 4,144,808 to Isawa et al. describes a method of printing on a metal plate utilizing powder toner and an intermediate transfer member where the plate is heated before transfer.

U. S. Patent 4,518,976 to Tarumi et al. describes a monochrome powder toner system in which a powder image is developed on a photoreceptor, and transferred electrostatically to an intermediate transfer member. Downstream this transfer, the intermediate transfer member and the image thereon are heated before transfer to a preheated substrate.

U. S. Patent 4,515,460 to Knechtel, describes a powder toner apparatus wherein separate toner images are sequentially developed on a photoreceptor and electrostatically transferred to an intermediate transfer member. After all of the individual images have been transferred to the intermediate transfer member, they are transferred electrostatically to the final substrate. No heating of the images or substrate is disclosed.

U. S. Patent 4,585,319 to Okamoto et al. describes a powder developer type, single color system, utilizing a temperature controlled photoreceptor, a heated intermediate transfer member and a heated transfer fixing roller which is heated to a temperature slightly higher than that of the intermediate transfer member.

U. S. Patent 4,690,539 to Raduleki et al. describes a liquid toner multi-color system in which a color image is developed on a photoreceptor and transferred to a belt type intermediate transfer member. The liquid carrier is removed from the toner image on the belt and a second image is transferred to the belt overlaying the first image. There is no mention of heating the intermediate transfer member or of the problem of back transfer.

U. S. Patent 4,708,460 to Langdon describes a single color liquid toner system in which a developed image is transferred from a photoreceptor to an intermediate transfer member, heated on the transfer member and then transferred to a final substrate.

U. S. Patent 3,847,478 to Young describes a duplex printing system, wherein a developed image is transferred from a photoconductor to an intermediate transfer member, a second image is developed on the photoconductor and both images are transferred electrostatically to opposite sides of a piece of paper passed between the intermediate transfer member and the photoreceptor.

U. S. Patent 4,684,238 describes intermediate transfer apparatus in which plurality of liquid images, which include a liquid carrier having toner particles dispersed therein, are attracted from a photoconductive member to an intermediate belt. Liquid carrier is removed from the intermediate belt by vacuum apparatus and the toner particles are compacted on the intermediate belt in image configuration. Thereafter, the toner particles are transferred from the intermediate belt to the copy sheet in image configuration by electrostatic attraction.

In U.S. Patents 3,318,212 and 3,893,761 there are described methods and devices in which a powder image being transported on a resiliently deformable intermediate support surface is softened and thus rendered sticky while present on that surface and then is transferred and fixed onto a paper receiving support under the influence of pressure.

U.S. Patent 4,015,027 describes an electrophotographic toner transfer and fusing method wherein a heated roller or belt is employed for pressure transfer of dry toner images from an intermediate transfer medium onto paper. At column 11, line 29 - column 12 line 38 there appears a detailed discussion of heating of images upon transfer thereof as proposed therein and as taught in the prior art including specifically U.S. Patent 3,591,276 to Byrne.

Reference is made to Figs. 5A - 5C, 6A - 6C, 7A and 7C of U.S. Patent 4,015,027. It is seen that in nearly all cases described, the toner is heated to at least its melting point during the transfer stage. In a technique proposed in U.S. Patent 4,015,027 and exemplified by Fig. 6(a), the toner is heated to at least its melting point prior to the transfer zone. In the transfer zone, the toner cools below its melting point during transfer and fusion.

A belt construction characterized in that it has a very low heat capacitance and a thickness of between 15 and about 200 microns is proposed in U.S. Patent 4,015,027. In one embodiment the belt comprises a 50 micron layer of aluminized Kapton having a 25 micron coating of silicon rubber. Another embodiment employs a 12.5 micron layer of stainless steel instead of the Kapton together with a silicon rubber coating. A reflecting layer is incorporated in the belt to reduce heating thereof.

U.S. Patent 4,796,048 describes a system for transferring a liquid toner image from a photoconductive member to an intermediate transfer member for subsequent transfer to a copy sheet. In several of the examples the liquid toner image is heated to remove solvent

associated with the toner image. The toner particles are melted to thermally offset the image to the copy sheet.

SUMMARY OF THE INVENTION

The present invention seeks to provide improved apparatus for image transfer.

It is an object of the present invention to provide a method and apparatus for the improved transfer of an image from an image bearing surface to an intermediate transfer member.

It is a further object of the present invention to provide a method and apparatus for the improved transfer of an image from an image bearing surface to an intermediate transfer member and subsequent transfer to a final substrate.

It is a further object of the present invention to provide a method and apparatus for the sequential transfer of a plurality of superimposed images to an intermediate transfer layer without back transfer.

There is thus provided a method of transferring a first liquid toner image from a first surface having a first temperature to a second surface having a second liquid toner image thereon to form multiple images on the second surface characterized in that it includes the steps of:

heating the second surface to a second temperature at transfer, which second temperature is higher than the first temperature; and transferring, preferably by electrophoresis, the first and second images to a final substrate from the second surface.

Preferably, the second temperature is lower than the temperature at which the second liquid toner image would transfer to the first surface from the second surface.

In a preferred embodiment of the invention the method includes:

forming the first liquid toner image on an image bearing surface using a liquid developer, comprising carrier liquid and charged toner particles; and transferring the first liquid toner image to the second surface.

Preferably, the step of forming the first liquid toner image includes the step of developing a latent electrostatic image on the image bearing surface.

In a preferred embodiment of the invention the method includes;

forming the first liquid toner image on the first surface using a liquid developer comprising carrier liquid and charged toner particles; transferring the first liquid toner image to the second surface at least partially superimposed on the second liquid toner image to form multiple images thereon.

eon.

Preferably, the step of forming the second liquid toner image includes the step of developing a latent electrostatic image on the first surface.

In a preferred embodiment of the invention during the step of transferring to the final substrate the multiple images are at a higher temperature than during the step of transferring the second liquid toner image to the second surface.

In a preferred embodiment of the invention, the step of transferring the first and second images to the final substrate comprises:

transferring the first and second images to a second intermediate transfer member; and transferring the first and second images to the final substrate.

Preferably, the method comprises the steps of:

forming at least one additional image on the first surface after transfer of the first and second images therefrom;

transferring the at least one additional image to the intermediate transfer member after the transfer of the first and second images from the intermediate transfer member to the second intermediate transfer member, but prior to their transfer to the final substrate; and

passing the final substrate through a nip formed between the intermediate transfer member and the second intermediate transfer member such that the first and second images are transferred to one side of the final substrate and the at least one additional image is transferred to the other side of the final substrate.

There is further provided imaging apparatus for printing multicolor images comprising:

means for forming a liquid toner image of a first color;

means for forming a second liquid toner image of a second color;

an intermediate transfer member;

first transfer means for sequentially transferring the first and second liquid toner images to the intermediate transfer member in mutual alignment to form a multicolor image thereon; and

second transfer means for transferring the multicolor image to a final substrate from the intermediate transfer member, characterized in that it includes:

first heating means for heating the formed images before completion of their respective transfers to the intermediate transfer member.

Preferably, the means for forming the first and second liquid toner images comprises means for developing an electrostatic latent image on a photoreceptor.

Preferably, the second transfer means includes a second intermediate transfer member adapted to receive images from the first intermediate transfer member prior to transfer of the images to the final substrate.

Preferably, the second transfer means includes a second intermediate transfer member adapted to receive images from the intermediate transfer member prior to transfer of the images to the final substrate.

In a preferred embodiment of the invention, the intermediate transfer member and the second intermediate transfer member are configured to form a nip therebetween and including means for passing the final substrate between the intermediate transfer member and the second intermediate transfer members carrying first and second multicolor images respectively such that said first and second images are transferred to opposite sides of the final substrate.

In accordance with a preferred embodiment of the invention the apparatus comprises:

second heating means for further heating of the developed first transferred image such that it is at a higher temperature during its transfer to the final substrate than during its transfer to the intermediate transfer member.

BRIEF DESCRIPTION OF THE DRAWINGS

The present invention will be understood and appreciated more fully from the following detailed description, taken in conjunction with the drawings in which:

Fig. 1 is a simplified sectional illustration of electrophotographic apparatus constructed and operative in accordance with a preferred embodiment of the present invention;

Fig. 2 is a simplified sectional illustration of electrophotographic apparatus constructed and operative in accordance with another preferred embodiment of the present invention;

Fig. 3 is a simplified sectional illustration of electrophotographic apparatus constructed and operative in accordance with yet another preferred embodiment of the present invention;

Fig. 4 is a simplified sectional illustration of a electrophotographic apparatus constructed and operative in accordance with yet another preferred embodiment of the present invention;

Fig. 5 is a simplified sectional illustration of electrophotographic apparatus constructed and operative in accordance with yet another preferred embodiment of the present invention;

Fig. 6 is a simplified sectional illustration of electrophotographic apparatus constructed and operative in accordance with yet another preferred embodiment of the present invention; and

Fig. 7 is a graphical illustration of the temperature variation along a low thermal mass intermediate transfer member in an arrangement such as that illustrated in Fig. 6.

DETAILED DESCRIPTION OF PREFERRED EMBODIMENTS

Reference is now made to Fig. 1 which illustrates electrophotographic imaging apparatus constructed and operative in accordance with a preferred embodiment of the present invention. This and other embodiments of the invention are described in the context of liquid developer systems with negatively charged toner particles and positively charged photoreceptors. Such systems operate in a "write-white" mode, for which areas which are not to be toned are exposed to light. The invention may be useful for other combinations of toner charge, photoreceptor charge as well as for other writing systems, such as "write-black" systems.

The apparatus of the invention is described using a liquid developer system. In accordance with a preferred embodiment of the invention the liquid developer of Example 1 of U. S. Patent 4,794,651 can be used, but other suitable developers may be used in the practice of the invention. Especially useful are liquid developers comprising toner particles which solvate the carrier liquid of the developer at elevated temperatures, above room temperature.

As in conventional electrophotographic systems, the apparatus of Fig. 1 comprises a drum 10 arranged for rotation about an axle 12 in a direction generally indicated by arrow 14. Drum 10 is formed with a cylindrical photoreceptor surface 16.

A corona discharge device 18 is operative to generally uniformly charge photoreceptor surface 16 with a positive charge. Continued rotation of drum 10 brings charged photoreceptor surface 16 into image receiving relationship with an exposure unit including a lens 20. Lens 20, focuses a desired image, which may be laser generated, onto charged photoreceptor surface 16, selectively discharging the photoreceptor surface, thus producing an electrostatic latent image thereon.

Continued rotation of drum 10 brings charged photoreceptor surface 16 bearing the electrostatic latent image into operative association with a development unit 22, operative to apply a liquid developer to develop the electrostatic latent image. For multicolor copying or printing, the development unit 22 can, for example, comprise a plurality of developers, one for each color, which are selectively engaged with the photoreceptor, as described, for example, in U.S. Patent 4,690,539, or a single development station where the liquid toner is changed between colors, or any other suitable development system. In general this development process takes place at a relatively low temperature, namely approximately the temperature of the environment of the system.

In accordance with a preferred embodiment of the invention, following application of toner thereto, photoreceptor surface 16 passes a typically positively charged rotating roller 26, preferably rotating in a direction indicated by an arrow 28. Roller 26 functions as a metering roller and reduces the thickness of liquid on photoreceptor surface 16. Typically the spatial separation of roller 26 from photoreceptor surface 16 is about 50 microns.

Preferably the voltage on roller 26 is intermediate the voltages of the latent image areas and of the background areas on the photoreceptor surface. Typical voltages are: roller 26: +200V, background area: +50V and latent image areas: up to about +1000V.

Liquid which passes roller 26 should be relatively free of pigmented particles except in the region of the latent image.

Downstream of roller 26 there is preferably provided a rigidizing roller 30. Rigidizing roller 30 is preferably formed of a resilient polymeric material, for example a slightly conductive resilient polymeric material as described in either or both of U.S. Patents 3,959,574 and 3,863,603. Roller 30 is preferably resiliently urged against photoconductive surface 16.

In a preferred embodiment of the invention, an electrically biased squeegee roller is used as roller 30. Roller 30 is negatively charged to a potential of at least several hundred and up to 2000 volts with the same sign as the charge on the pigmented toner particles, so that it repels similarly charged pigmented particles and causes them to more closely approach the image areas of the photoreceptor surface 16, thus compressing and rigidizing the image.

Downstream of rigidizing roller 30 there is provided an intermediate transfer member 40, which rotates in a direction opposite to that of photoreceptor surface 16, as shown by arrow 41, providing zero relative motion between their respective surfaces at the point of proximity. Intermediate transfer member 40 is operative for receiving the toner image from photoreceptor surface 16 and for transferring the toner image to a receiving substrate 42, such as paper. Disposed internally of intermediate transfer member 40 there may be provided a heater 46, to heat intermediate transfer member 40.

Various types of intermediate transfer members are known and are described, for example in U.S. Patent 4,684,238, PCT Publication WO 90/04216 and U. S. Patent 4,974,027.

Following the transfer of the toner image to intermediate transfer member 40, photoreceptor surface 16 engages a cleaning station 49. This station may be any conventional cleaning station, comprising a cleaning roller 50 which may comprise a suitable resilient material such as foam polyethylene or neoprene. Cleaning roller 50 may be wetted by clean lubricating cleaning liquid, which preferably comprises liquid developer from which all or nearly all of the toner particles have been removed. Cleaning roller 50 is driven so that its surface

moves opposite to surface 16 at their nip, to provide scrubbing action for removal of residual particles and carrier liquid from photoreceptor surface 16. A scraper 56 completes the removal of any residual toner which may not have been removed by cleaning station 49.

A lamp 58 completes the cycle by removing any residual charge, characteristic of the previous image, from semiconductor surface 16.

Transfer of the image to intermediate transfer member 40 is preferably aided by providing electrification of intermediate transfer member 40 to a voltage opposite that of the charged particles, thereby causing transfer by electrophoresis. It has been found by the inventors, that, at least for the preferred developer, raising the temperature of the developed toner image to a temperature higher than the development temperature and room temperature aids this first transfer, even when the transfer is by electrophoresis.

Subsequent final transfer of the image from intermediate transfer member 40 to substrate 42 is preferably aided by heat and pressure. A higher temperature than that used for first transfer is preferably utilized for this subsequent final transfer.

In the prior art a liquid toner image was first transferred to an intermediate transfer member. The toner image was heated during the interval between first and second transfer so as to aid in final transfer.

In the present invention the preferred first transfer step, i.e., the transfer of the liquid toner image to the intermediate transfer member includes the heating of the image either before or during first transfer. The preferred final transfer step, i.e., the transfer of the liquid toner image to the final substrate, includes the further heating of the image before and/or during second transfer. This further heating can be achieved by heating the image on intermediate transfer member 40, for example by heat transfer from intermediate transfer member 40 during the interval between first and final transfer and/or by external heating of the image. Preferably the image is heated to a temperature at which it solvates liquid to form a single phase, without evaporating substantial amounts of liquid carrier. Alternatively or additionally the further heating can be achieved by conduction heating of the image from the final substrate during final transfer.

These preferred first and second transfer steps improve the quality of the image on the final substrate both for single color and for multi-color images.

For multicolor systems it is useful to sequentially transfer the separate colors to the intermediate transfer member 40 in alignment with and generally superimposed and in registration with each other and then to transfer them together to paper or other substrate 42. It has then been found that for this configuration, there is a tendency for the heated images previously transferred to the intermediate transfer member at a lower temperature, to transfer back, in whole or in part, to photoreceptor surface 16, when the previously transferred image returns to the point of first transfer.

The embodiments of the invention described herein provide improved first and final transfer and for multi-color systems can solve the back transfer problem.

In general, some of the embodiments of the invention are characterized in that photoreceptor 16 is at a first, relatively low temperature; intermediate transfer member 40 is at a second, somewhat higher temperature, to provide for improved first transfer; and final substrate 42 is at a third, even higher temperature to provide for good transfer from intermediate transfer member 40 to substrate 42.

Alternatively or additionally, some of the embodiments can be characterized in that, when a toner image is transferred from photoreceptor surface 16 to intermediate transfer member 40, and then to final substrate 42, the toner image is hotter during transfer to the intermediate transfer member than it was on the photoreceptor surface and the image is hotter when it is transferred to the final substrate, than during the earlier transfer.

Alternatively or additionally, some of the embodiments can be characterized in that, when multiple toner images are transferred sequentially from photoreceptor surface 16 to intermediate transfer member 40, and then to final substrate 42 as a group, the composite, multi-color toner image is hotter when it is transferred to the final substrate than during any contact of earlier transferred images with the photoreceptor.

One embodiment of the invention can be characterized in that the image is transferred from a photoreceptor surface, at a first relatively low temperature to a first intermediate transfer member at a second intermediate temperature. The image is then transferred to a second intermediate transfer member. Final transfer takes place from the second intermediate transfer member to the final substrate at a third, higher temperature. Preferably, the image temperature during first transfer is higher than that of that portion of the photoreceptor surface not in contact with the intermediate transfer member.

Returning now to Fig. 1, intermediate transfer member 40 is heated to a temperature sufficient to enhance the electrophoretic transfer of toner particles from photoreceptor surface 16 to intermediate transfer member 40. The image is heated during transfer to intermediate transfer member 40, and the heating continues while the image is on intermediate transfer member 40 until the image is at the temperature of intermediate transfer member 40. Rotation of intermediate transfer member 40 brings the heated intermediate transfer member 40 into image transfer relationship with a final substrate 42, which is pressed against the intermediate transfer member by a heated backing roller 43. Heated backing roller 43 heats the paper and thereby heats the image in contact therewith by conduction from the paper, to a sufficient degree to ensure that complete or nearly complete final transfer of the image to the substrate, by heat and pressure, takes place.

While the invention has been described in a monochromatic version, where it gives improved transfer from

the photoreceptor to the intermediate transfer member and from the intermediate transfer member to the final substrate, the invention is particularly useful in a multi-color system, wherein images of different colors are sequentially formed on photoreceptor surface 16, and transferred one by one in mutual alignment to image transfer member 40 prior to a single transfer of all of the images, which form a multicolor image, to final substrate 42.

Final substrate 42 is brought into transfer engagement with intermediate transfer member 40 only when all of the colors have been transferred to intermediate transfer member 40, for final transfer of the multicolor image to substrate 42.

As noted above, it is appreciated that during first transfer of subsequent images from photoreceptor surface 16 to image transfer member 40, earlier transferred images return to the region of first transfer. Any back transfer of previously transferred images to photoreceptor surface 16 will result in undesirable artifacts in the final printed image.

Generally if the intermediate transfer member is heated to a temperature which is useful for good final transfer, then there is a tendency for the image to back transfer to the photoreceptor.

The arrangement of Fig. 1, with proper choice of temperatures for intermediate transfer member 40 at first transfer, and for final substrate 42 and the image at second transfer in accordance with the present invention, substantially eliminates the problem of back transfer to photoreceptor surface 16, by keeping the image temperature, when the image on the intermediate transfer member returns to the photoreceptor, low enough so that it is not tacky enough to stick to the photoreceptor.

Fig. 2 shows a second embodiment of the invention in which all of the parts and operation are generally the same as those of the apparatus of Fig. 1, except that heated backing roller 43 is replaced by an unheated backing roller 44, and final substrate 42 is preheated by a heating lamp 45. A combination of the embodiments of Figs. 1 and 2 is also useful, whereby paper 42 is preheated by lamp 45, and heated roller 43 is used.

A third embodiment of the apparatus of the invention is shown in Fig. 3. In this case intermediate transfer member 40 is heated to a first, moderate, temperature which is high enough to enhance first transfer, but not so high as to cause substantial back transfer of previously transferred images from intermediate transfer member 40 to photoreceptor surface 16. The images are transferred to a second intermediate transfer member 47 which is heated by an internal heater 48 to a higher temperature, sufficient to assure good final transfer to final substrate 42.

In a preferred embodiment of the invention, intermediate transfer member 40 is maintained at a first voltage (different from the voltage of the photoreceptor surface 16) to enhance transfer of the image thereto from photoreceptor surface 16, and second intermediate

transfer member 47 is electrified to a second voltage, different from the first voltage, to enhance transfer of the image thereto from intermediate transfer member 40.

Transfer to second intermediate transfer member 41 can occur sequentially for each of the images, or preferably the images are collected on first intermediate transfer member 40 and then the multicolor image is transferred as a whole to second intermediate transfer member 47 for final transfer to the final substrate 42.

A duplex embodiment of the invention, for printing two sides of a substrate at the same time is shown in Fig. 4. The separate color images which make up the multi-colored image to be printed on a first side of substrate 42 are first transferred sequentially to intermediate transfer member 40 and then are transferred, preferably as a group, to second intermediate transfer member 47. Second image transfer member 47 is preferably heated to a higher temperature than intermediate transfer member 40. The images to be printed on the other side of the page are subsequently transferred sequentially to intermediate transfer member 40, which is meanwhile kept out of transfer engagement with second intermediate transfer member 47.

Final substrate 42 is then passed between intermediate transfer member 40 and second intermediate transfer member 47, while pressing the two intermediate transfer members together to effect transfer of the images to both sides of the paper by heat and pressure. It is understood that preferably second intermediate transfer member 47 heats substrate 42 and the image to a suitable temperature to assure good transfer of the image on intermediate transfer member 40 to substrate 42. Alternatively or additionally, the paper may be heated before transfer as described above in connection with Fig. 2.

In some preferred embodiments of the invention intermediate transfer member 40 acts to heat the image to a first temperature during first transfer from photoreceptor 16 to intermediate transfer member 40, and to heat the image to a second higher temperature before second and final transfer from intermediate transfer member 40 to final substrate 42.

Exemplary embodiments include the apparatus shown in Fig. 5. This apparatus is generally the same as the apparatus of Fig. 1, except that a cooling station 60 is operatively associated with intermediate transfer member 40 just before it returns to make contact with photoreceptor surface 16. Intermediate transfer member 40 is cooled at cooling station 60 to locally reduce the temperature of intermediate transfer member 40 before and during contact with the image on the photoreceptor. This local cooling allows the liquid toner image to be hotter at the point of final transfer from intermediate transfer member 40 to final substrate 42 than it is at first transfer from photoreceptor surface 16 to intermediate transfer member 40.

Cooling station 60 may comprise, for example, apparatus for providing a stream of cool air to the surface

of the photoreceptor or a cooled roller in contact with the photoreceptor surface. Either or both cooling systems cool intermediate transfer member 40 to a temperature, higher than room temperature, but lower than the final transfer temperature.

In a multicolor system, if a roller cooler is used it is coated with a non-stick coating to avoid transfer of the image from intermediate transfer member 40 to the roller of cooling station 60.

Another exemplary embodiment of this type is illustrated in Fig. 6, which is essentially the same as Fig. 8 of WO 90/04216 previously referenced. Here an intermediate transfer member 140 is of low heat capacity, and is heated only after first transfer is completed. As shown in Fig. 7, which is the same as Fig. 9 of the above referenced application, the temperature at the first transfer is above room temperature in order to improve first transfer, and the temperature at second transfer is even higher to assure complete or nearly complete second transfer. For a multi-color system the temperatures and heat capacities are selected so that the first transfer takes place at a temperature low enough to avoid back transfer.

In the above embodiments, intermediate transfer members 40 and 47 have been described as having heaters placed internal to the core to heat each of them to its required temperature. Other methods of heating intermediate transfer members known in the art can also be used in the practice of the invention.

Examples

Colored liquid developer is prepared in the following manner:

Preparation of Black Liquid Developer

10 parts by weight of Elvax 5720 (E. I. Du Pont) and 5 parts by weight of Isopar L are mixed at low speed in a jacketed double planetary mixer connected to an oil heating unit for one hour, the heating unit being set at 130 degrees C.

A mixture of 2.5 parts by weight of Mogul L carbon black (Cabot) and 5 parts by weight of Isopar L are then added to the mix in the double planetary mixer and the resultant mixture is further mixed for one hour at high speed. 20 parts by weight of Isopar L preheated to 110 degrees C are added to the mixer and mixing is continued at high speed for one hour. The heating unit is then disconnected and mixing is continued until the temperature of the mixture drops to 40 degrees C.

The resulting mixture is transferred to an S-1 attritor device equipped with 3/16 inch carbon steel media, diluted with Isopar L to a 16% solids ratio and ground without cooling until the temperature rises to about 60 degrees C. Cooling, which reduces the temperature to about 30 degrees is then commenced and grinding is continued for a total of 24 hours. The mixture is removed

from the device and diluted with Isopar L to 1.5% by weight solids concentration. The particles in the resultant toner concentrate have an average diameter of 2.5 microns.

Charge director as known in the art, is added to give the final liquid developer. In a preferred embodiment of the invention the charge director of Example 1 of PCT publication WO 90/14617, is added to give the final liquid developer.

Preparation of Colored Developer

10 parts by weight of Elvax 5720 (E. I. Du Pont) and 5 parts by weight of Isopar L are mixed at low speed in a jacketed double planetary mixer connected to an oil heating unit for one hour, the heating unit being set at 130 degrees C.

Pre-heated Isopar L is then added to reduce the solids concentration to preferably 35% and mixing is continued at high speed for one hour. The heating unit is then disconnected and mixing is continued until the temperature of the mixture drops to 40 degrees C.

The mixture is then transferred to an S-1 attritor device equipped with 3/16 inch carbon steel media and pigment is added to the material in the attritor. The mixture is diluted with Isopar L to about a 12-16% solids ratio, depending on the viscosity of the material and is ground without cooling until the temperature rises to about 60 degrees C. Cooling, which reduces the temperature to about 30 degrees, is then commenced and grinding is continued for a total of 24 hours. The mixture is removed from the device and diluted with Isopar L to 1.5% by weight solids concentration. The particles in the resultant toner concentrate had an average diameter of 2.5 microns.

Charge director as known in the art, is added to give the final liquid developer. In a preferred embodiment of the invention the charge director of Example 1 the above referenced PCT publication WO 90/14617 is added to give the final liquid developer.

Appropriate colored pigments known in the art of liquid developer manufacture, for example the list given in U. S. Patent 4,794,651 can be used. Other suitable pigments are Sico Fast Yellow D1350 (BASF), Lithol Rubin D4576 (BASF), Lyonol Blue FG7351 (TOYO) and Lyonol Yellow 7G1310 (TOYO). in amounts and combinations depending on the color and intensity required. Optionally, Aluminum Stearate can be added in small amounts. For pigments which are discolored by steel, other grinding media such as zirconia may be used.

These developers are used to form the individual color liquid toner images on photoreceptor surface 16 which comprise a relatively high concentration of toner particles in carrier liquid.

Photoreceptor surface 16 is preferably formed of selenium. Intermediate transfer member 40 is preferably formed of a cylindrical aluminum core coated with a 1 mm thick layer of very soft polyurethane having a hard-

ness of 20-25 Shore A. This layer is covered by an offset printing blanket, preferably a KYNIO AIRTACK offset blanket, which is much harder than the polyurethane. A thin conducting layer of conducting acrylic covers this layer and is covered in turn by a 0.1 mm layer of polyurethane of shore A Hardness 20. This layer is overcoated by a thin layer of Syl-Off type 291 or 294 silicone release coating.

Liquid developer prepared in accordance with the method described above is used in the equipment of Fig. 1. Preferably the temperature of the intermediate transfer layer should be less than about 50 degrees C. For temperatures greater than about 50 degrees, there is a tendency for the previously transferred colors to back transfer to photoreceptor surface 16. Heating intermediate transfer member 40 improves image transfer to intermediate transfer member 40. Intermediate transfer member 40 is preferably heated to a temperature somewhat below that at which back transfer begins to occur.

It is believed that the improvement in first transfer when the intermediate transfer member is heated may be a consequence of partial solvation of carrier liquid by the pigmented toner particles in the image.

One characteristic of the liquid developers preferred in the practice of this invention is that the pigmented toner particles contained therein solvate the carrier liquid at elevated temperatures. It is believed that there is a partial solvation of the carrier liquid in the toner particles during first transfer to heated intermediate transfer member 40 which may cause the particles to partially coalesce and form a film during first transfer. Coalesced toner is believed to transfer better than uncoalesced toner particles.

Furthermore, when the toner material solvates some of the carrier liquid, the toner particles separate from the unsolvated carrier liquid. It is believed that this separated carrier liquid forms a film between the toner image and the photoreceptor which reduces the adhesion of the image to the photoreceptor, aiding complete transfer of the image to the intermediate transfer member.

It is to be understood that the heating of the image before and/or during final transfer insures the complete or nearly complete transfer of the image from the intermediate transfer member to the final substrate. Where this image heating comes solely by conduction from the paper, it has been found experimentally that the paper should be at a temperature of at least about 70 degrees C. Higher temperatures such as 80 or 90 degrees can also be used, but substantially lower temperatures do not tackify the image enough to assure complete transfer from intermediate transfer member 40 to paper 42.

The precise temperatures used for particular configurations and combinations are a function of the material properties of the toner particles and the carrier liquid as well as of the quality of the release layer on the intermediate transfer member. Back transfer occurs due to the tackiness of the image, but is also influenced by

the relative adhesion of the image to the release layer on the intermediate transfer member and to the photoreceptor. It would be possible to increase the temperature of the intermediate transfer member if the release properties of the surface of the intermediate transfer member were poorer. This however would also result in poorer transfer to the final substrate.

In particular representative, operating examples the following temperatures are used. In a first example, which is used for the transfer of single color images, the intermediate transfer member is heated to a surface temperature of 100 degrees C and the paper is not heated. Calculations show that the image is at a temperature of 52 to 63 degrees C during first transfer. During the interval between first and second transfer the image temperature rises to the intermediate transfer member's temperature of 100 degrees C, and the image is cooled during second, final transfer to paper to a temperature of 73 to 78 degrees C.

In a second, representative, operating example for sequential transfer of multiple images to the intermediate transfer member, the intermediate transfer member is heated to 50 degrees C and backing roller 43 is heated to 120 degrees C. The image temperature on first transfer is approximately 43 degrees C and on second transfer it is 75 to 78 degrees C.

The temperatures shown in figure 7 are also representative of values suitable for single image transfer. For multi-image transfer to intermediate transfer member 140, the first transfer temperature must be low enough to assure that no back transfer takes place.

It will be understood that certain features and sub-combinations of the invention are useful, and may be employed without other features and sub-combinations. It is noted that various changes may be made in details within the scope of the claims. It is therefore to be understood that the invention is not to be limited to the specific details shown and described.

Claims

1. A method of transferring a first liquid toner image from a first surface having a first temperature to a second surface having a second liquid toner image thereon to form multiple images on the second surface characterized in that it includes the steps of:

heating the second surface to a second temperature at transfer, which second temperature is higher than the first temperature; and transferring the first and second images to a final substrate from the second surface.

2. A method according to claim 1 wherein the second temperature is lower than the temperature at which the second liquid toner image would transfer to the first surface from the second surface.

3. A method according to claim 1 or claim 2 wherein the step of transferring is by electrophoresis.

4. A method according to any of the preceding claims and including the steps of:

forming the first liquid toner image on an image bearing surface using a liquid developer, comprising carrier liquid and charged toner particles; and transferring the first liquid toner image to the second surface.

5. A method according to claim 4 wherein the step of forming the first liquid toner image includes the step of developing a latent electrostatic image on the image bearing surface.

6. A method according to any of the preceding claims and including the steps of:

forming the first liquid toner image on the first surface using a liquid developer comprising carrier liquid and charged toner particles; transferring the first liquid toner image to the second surface at least partially superimposed on the second liquid toner image to form multiple images thereon.

7. A method according to claim 6 wherein the step of forming the second liquid toner image includes the step of developing a latent electrostatic image on the first surface.

8. A method according to any of the preceding claims wherein during the step of transferring to the final substrate the multiple images are at a higher temperature than during the step of transferring the second liquid toner image to the second surface.

9. A method according to any of the preceding claims wherein the step of transferring the first and second images to the final substrate comprises:

transferring the first and second images to a second intermediate transfer member; and transferring the first and second images to the final substrate.

10. A method according to claim 9 and including the steps of:

forming at least one additional image on the first surface after transfer of the first and second images therefrom; transferring the at least one additional image to the intermediate transfer member after the transfer of the first and second images from the

intermediate transfer member to the second intermediate transfer member, but prior to their transfer to the final substrate; and passing the final substrate through a nip formed between the intermediate transfer member and the second intermediate transfer member such that the first and second images are transferred to one side of the final substrate and the at least one additional image is transferred to the other side of the final substrate.

11. Imaging apparatus for printing multicolor images comprising:

means (20, 22) for forming a liquid toner image of a first color;
 means (20, 22) for forming a second liquid toner image of a second color;
 an intermediate transfer member (40);
 first transfer means for sequentially transferring the first and second liquid toner images to the intermediate transfer member in mutual alignment to form a multicolor image thereon; and
 second transfer means for transferring the multicolor image to a final substrate from the intermediate transfer member, characterized in that it includes:
 first heating means (46) for heating the formed images before completion of their respective transfers to the intermediate transfer member.

12. Apparatus according to claim 11 wherein the means for forming (20, 22) the first and second liquid toner images comprises means (22) for developing an electrostatic latent image on a photoreceptor.

13. Apparatus according to claim 11 or claim 12 wherein the second transfer means includes a second intermediate transfer member (47) adapted to receive images from the intermediate transfer member (40) prior to transfer of the images to the final substrate (42).

14. Apparatus according to claim 13 wherein the intermediate transfer member and the second intermediate transfer member are configured to form a nip therebetween and including means for passing the final substrate between the intermediate transfer member and the second intermediate transfer members carrying carry first and second multicolor images respectively, such that said first and second images are transferred to opposite sides of the final substrate.

15. Apparatus according to any of claims 11-14 and comprising:
 second heating means (45, 43, 46, 48, 114) for further heating of the developed first transferred

image such that it is at a higher temperature during its transfer to the final substrate than during its transfer to the intermediate transfer member.

Patentansprüche

1. Verfahren zum Übertragen eines ersten Flüssigtonerbildes von einer ersten Oberfläche mit einer ersten Temperatur auf eine zweite Oberfläche mit einem zweiten Flüssigtonerbild darauf, um auf der zweiten Oberfläche Mehrfachbilder zu erzeugen, dadurch gekennzeichnet, daß dieses die Schritte umfaßt:

Erwärmen der zweiten Oberfläche auf eine zweite Temperatur bei der Übertragung, wobei diese zweite Temperatur höher ist als die erste Temperatur; und
 Übertragen des ersten und zweiten Bildes von der zweiten Oberfläche auf ein Endsubstrat.

2. Verfahren nach Anspruch 1, in welchem die zweite Temperatur niedriger als die Temperatur ist, bei welcher das zweite Flüssigtonerbild von der zweiten Oberfläche auf die erste Oberfläche übertragen werden würde.

3. Verfahren nach Anspruch 1 oder 2, in welchem der Schritt des Übertragens durch Elektrophorese erfolgt.

4. Verfahren nach einem der vorstehenden Ansprüche und mit den Schritten:

Erzeugen des ersten Flüssigtonerbildes auf einer bildtragenden Oberfläche unter Verwendung eines Flüssigentwicklers, der eine Trägerflüssigkeit und geladene Tonerteilchen umfaßt; und
 Übertragen des ersten Flüssigtonerbildes auf die zweite Oberfläche.

5. Verfahren nach Anspruch 4, in welchem der Schritt des Erzeugens eines ersten Flüssigtonerbildes den Schritt des Entwickelns eines elektrostatischen Latentbildes auf der bildtragenden Oberfläche umfaßt.

6. Verfahren nach einem der vorstehenden Ansprüche und mit den Schritten:

Erzeugen des ersten Flüssigtonerbildes auf der ersten Oberfläche unter Verwendung eines Flüssigentwicklers, der eine Trägerflüssigkeit und geladene Tonerteilchen umfaßt;
 Übertragen des ersten Flüssigtonerbildes auf die zweite Oberfläche, wenigstens teilweise

das zweite Flüssigtonerbild überlagernd, um darauf Mehrfachbilder zu erzeugen.

7. Verfahren nach Anspruch 6, in welchem der Schritt des Erzeugens des zweiten Flüssigtonerbildes den Schritt des Entwickelns eines elektrostatischen Latentbildes auf der ersten Oberfläche umfaßt.

8. Verfahren nach einem der vorstehenden Ansprüche, in welchem sich während des Schrittes der Übertragung auf das Endsubstrat die Mehrfachbilder auf einer höheren Temperatur befinden als während des Schrittes der Übertragung des zweiten Flüssigtonerbildes auf die zweite Oberfläche.

9. Verfahren nach einem der vorstehenden Ansprüche, in welchem der Schritt des Übertragens des ersten und des zweiten Bildes auf das Endsubstrat umfaßt:

ein Übertragen des ersten und des zweiten Bildes auf ein zweites Zwischenübertragungselement; und
ein Übertragen des ersten und des zweiten Bildes auf das Endsubstrat.

10. Verfahren nach Anspruch 9 und mit den Schritten:

Erzeugen wenigstens eines zusätzlichen Bildes auf der ersten Oberfläche nach der Übertragung des ersten und des zweiten Bildes von dieser;

Übertragen des wenigstens einen zusätzlichen Bildes auf das Zwischenübertragungselement nach der Übertragung des ersten und zweiten Bildes von dem Zwischenübertragungselement auf das zweite Zwischenübertragungselement aber vor deren Übertragung auf das Endsubstrat; und

Hindurchführen des Endsubstrats durch einen zwischen dem Zwischenübertragungselement und dem zweiten Zwischenübertragungselement ausgebildeten Spalt, derart, daß das erste und das zweite Bild auf eine Seite des Endsubstrats übertragen wird und das wenigstens eine zusätzliche Bild auf die andere Seite des Endsubstrats übertragen wird.

11. Bilderzeugungsvorrichtung zum Drucken von Mehrfarbenbildern mit:

einer Einrichtung (20, 22) zum Erzeugen eines Flüssigtonerbildes einer ersten Farbe;
einer Einrichtung (20, 22) zum Erzeugen eines zweiten Flüssigtonerbildes einer zweiten Farbe;
einem Zwischenübertragungselement (40);
einer ersten Übertragungseinrichtung zum se-

quentiellen Übertragen des ersten und des zweiten Flüssigtonerbildes auf das Zwischenübertragungselement in gegenseitiger Ausrichtung, um darauf ein Mehrfarbenbild zu erzeugen; und

einer zweiten Übertragungseinrichtung zum Übertragen des Mehrfarbenbildes von dem Zwischenübertragungselement auf ein Endsubstrat, dadurch gekennzeichnet, daß diese umfaßt:

eine erste Heizeinrichtung (46) zum Erwärmen der erzeugten Bilder vor Beendigung ihrer jeweiligen Übertragungen auf das Zwischenübertragungselement.

12. Vorrichtung nach Anspruch 11, in welcher die Einrichtung (20, 22) zum Erzeugen des ersten und des zweiten Tonerbildes ein Mittel (22) zum Entwickeln eines elektrostatischen Latentbildes auf einem Photorezeptor umfaßt.

13. Vorrichtung nach Anspruch 11 oder Anspruch 12, in welcher die zweite Übertragungseinrichtung ein zweites Übertragungselement (47) umfaßt, das so angepaßt ist, daß es Bilder von dem Zwischenübertragungselement (40) vor einer Übertragung der Bilder auf das Endsubstrat (42) erhält.

14. Vorrichtung nach Anspruch 13, in welchem das Zwischenübertragungselement und das zweite Zwischenübertragungselement so ausgebildet sind, daß sie zwischen sich einen Spalt bilden, und mit einem Mittel zum Hindurchführen des Endsubstrats zwischen dem Zwischenübertragungselement und dem zweiten Zwischenübertragungselement, die ein erstes bzw. ein zweites Mehrfarbenbild tragen, derart, daß das erste und das zweite Bild auf entgegengesetzte Seiten des Endsubstrats übertragen werden.

15. Vorrichtung nach einem der Ansprüche 11-14 und mit:

einer zweiten Heizeinrichtung (45, 43, 46, 48, 114) zum weiteren Erwärmen des entwickelten, ersten übertragenen Bildes, derart, daß es sich während seiner Übertragung auf das Endsubstrat auf einer höheren Temperatur befindet als während seiner Übertragung auf das Zwischenübertragungselement.

Revendications

1. Procédé de transfert d'une première image de toner liquide d'une première surface se trouvant à une première température à une deuxième surface sur laquelle se trouve une deuxième image de toner liquide afin de former des images multiples sur la

deuxième surface, caractérisé en ce qu'il comprend les étapes de :

- chauffage de la deuxième surface à une deuxième température au niveau du transfert, laquelle deuxième température est plus élevée que la première température, et
 - transfert des première et deuxième images de la deuxième surface à un substrat final.
2. Procédé selon la revendication 1, dans lequel la deuxième température est inférieure à la température à laquelle la deuxième image de toner liquide serait transférée de la deuxième surface à la première surface.
3. Procédé selon la revendication 1 ou la revendication 2, dans lequel l'étape de transfert se fait par électrophorèse.
4. Procédé selon l'une quelconque des précédentes revendications et comprenant les étapes de :
- formation de la première image de toner liquide sur une surface de support d'image à l'aide d'un révélateur liquide comprenant un liquide porteur et des particules de toner chargées, et
 - transfert de la première image de toner liquide à la deuxième surface.
5. Procédé selon la revendication 4, dans lequel l'étape de formation de la première image de toner liquide comprend l'étape de révélation d'une image électrostatique latente sur la surface de support d'image.
6. Procédé selon l'une quelconque des précédentes revendications et comprenant les étapes de :
- formation de la première image de toner liquide sur la première surface à l'aide d'un révélateur liquide comprenant un liquide porteur et des particules de toner chargées, et
 - transfert de la première image de toner liquide à la deuxième surface en superposition au moins partielle avec la deuxième image de toner liquide pour y former des images multiples.
7. Procédé selon la revendication 6, dans lequel l'étape de formation de la deuxième image de toner liquide comprend l'étape de révélation d'une image électrostatique latente sur la première surface.
8. Procédé selon l'une quelconque des précédentes revendications, dans lequel pendant l'étape de transfert au substrat final les images multiples sont à une température plus élevée que pendant l'étape de transfert de la deuxième image de toner liquide

à la deuxième surface.

9. Procédé selon l'une quelconque des précédentes revendications, dans lequel l'étape de transfert des première et deuxième images au substrat final comprend :
- le transfert des première et deuxième images à un deuxième organe de transfert intermédiaire, et
 - le transfert des première et deuxième images au substrat final.
10. Procédé selon la revendication 9 et comprenant les étapes de :
- formation d'au moins une image supplémentaire sur la première surface après transfert depuis celle-ci des première et deuxième images, transfert de l'image supplémentaire au nombre d'au moins une à l'organe de transfert intermédiaire après le transfert des première et deuxième images de l'organe de transfert intermédiaire au deuxième organe de transfert intermédiaire mais avant leur transfert au substrat final, et
 - passage du substrat final par une zone de pincement formée entre l'organe de transfert intermédiaire et le deuxième organe de transfert intermédiaire de telle sorte que les première et deuxième images soient transférées sur une face du substrat final et que l'image supplémentaire au nombre d'au moins une soit transférée à l'autre face du substrat final.
11. Appareil de formation d'image servant à imprimer des images multicolores, comprenant :
- des moyens (20, 22) servant à former une image de toner liquide d'une première couleur,
 - des moyens (20, 22) servant à former une image de toner liquide d'une deuxième couleur,
 - un organe de transfert intermédiaire (40),
 - un premier moyen de transfert servant à transférer séquentiellement les première et deuxième images de toner liquide à l'organe de transfert intermédiaire en alignement mutuel pour y former une image multicolore, et
 - un deuxième moyen de transfert servant à transférer l'image multicolore de l'organe de transfert intermédiaire à un substrat final, caractérisé en ce qu'il comprend un premier moyen de chauffage (46) servant à chauffer les images formées avant que leur transfert respectif sur l'organe de transfert intermédiaire ne soit terminé.
12. Appareil selon la revendication 11, dans lequel les

moyens (20, 22) de formation des première et deuxième images de toner liquide comprennent un moyen (22) servant à révéler une image électrostatique latente sur un photorécepteur.

5

- 13.** Appareil selon la revendication 11 ou la revendication 12, dans lequel le deuxième moyen de transfert comprend un deuxième organe de transfert intermédiaire (47) apte à recevoir des images de l'organe de transfert intermédiaire (40) avant le transfert des images au substrat final (42). 10
- 14.** Appareil selon la revendication 13, dans lequel l'organe de transfert intermédiaire et le deuxième organe de transfert intermédiaire sont configurés pour former entre eux une zone de pincement et comprenant un moyen servant à faire passer le substrat final entre l'organe de transfert intermédiaire et le deuxième organe de transfert intermédiaire portant respectivement une première et une deuxième images multicolores, de sorte que lesdites première et deuxième images sont transférées sur les faces opposées du substrat final. 15
20
- 15.** Appareil selon l'une quelconque des revendications 11 à 14 et comprenant des deuxièmes moyens de chauffage (45, 43, 46, 48, 114) servant à chauffer davantage l'image révélée et transférée une première fois de façon à ce qu'elle soit à une température plus élevée pendant son transfert au substrat final que pendant son transfert à l'organe de transfert intermédiaire. 25
30

35

40

45

50

55

FIG. 1

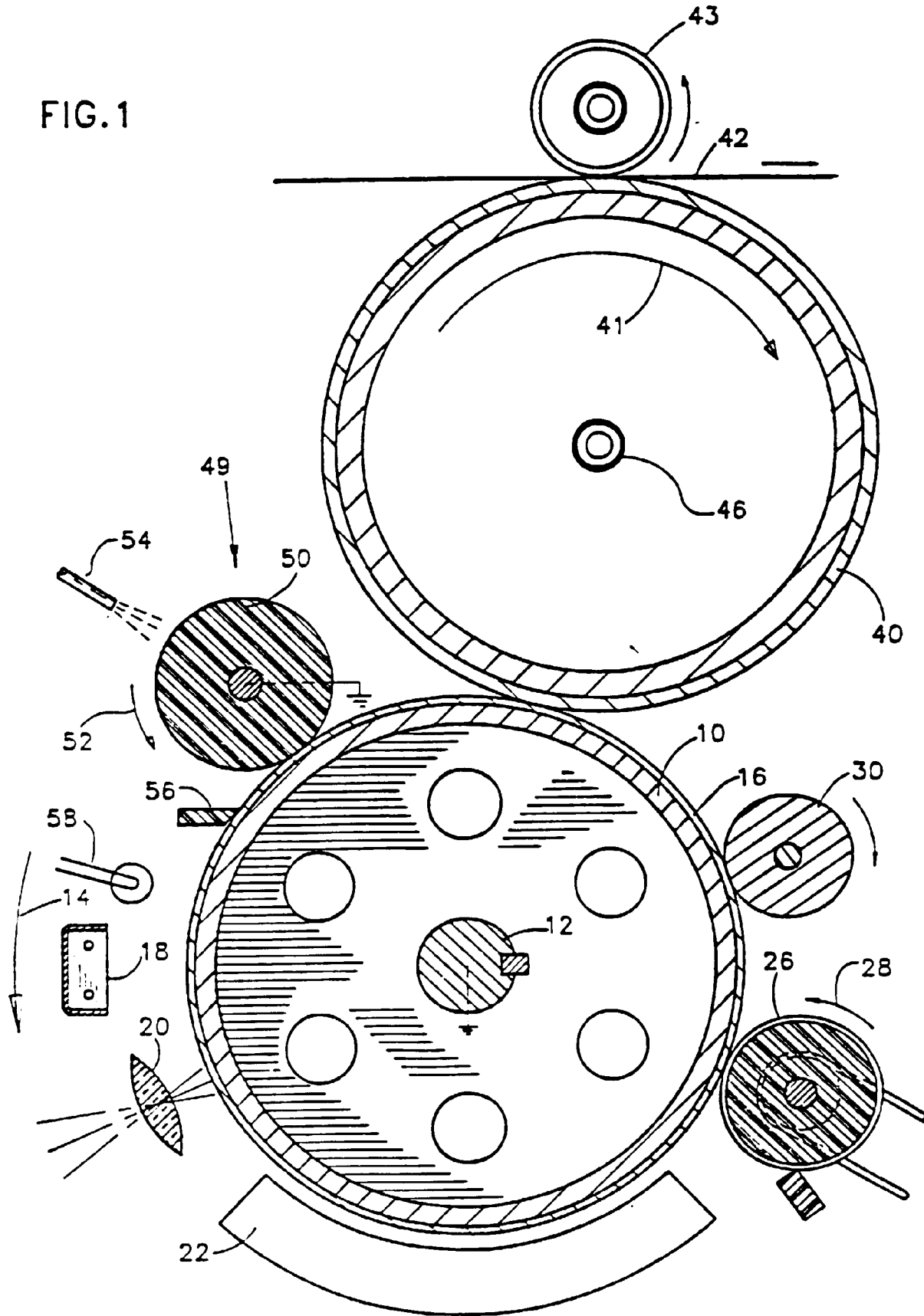
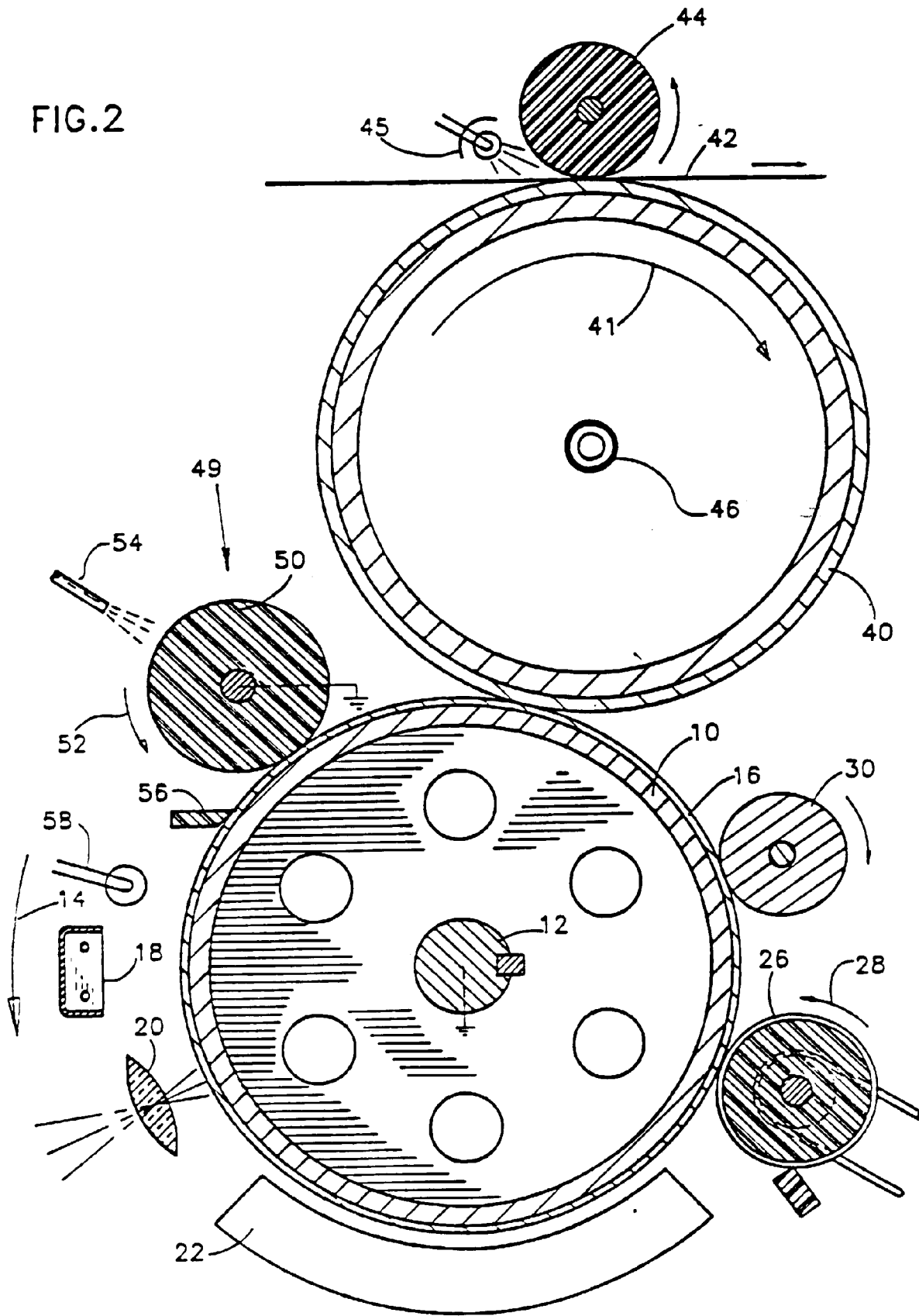

FIG.2



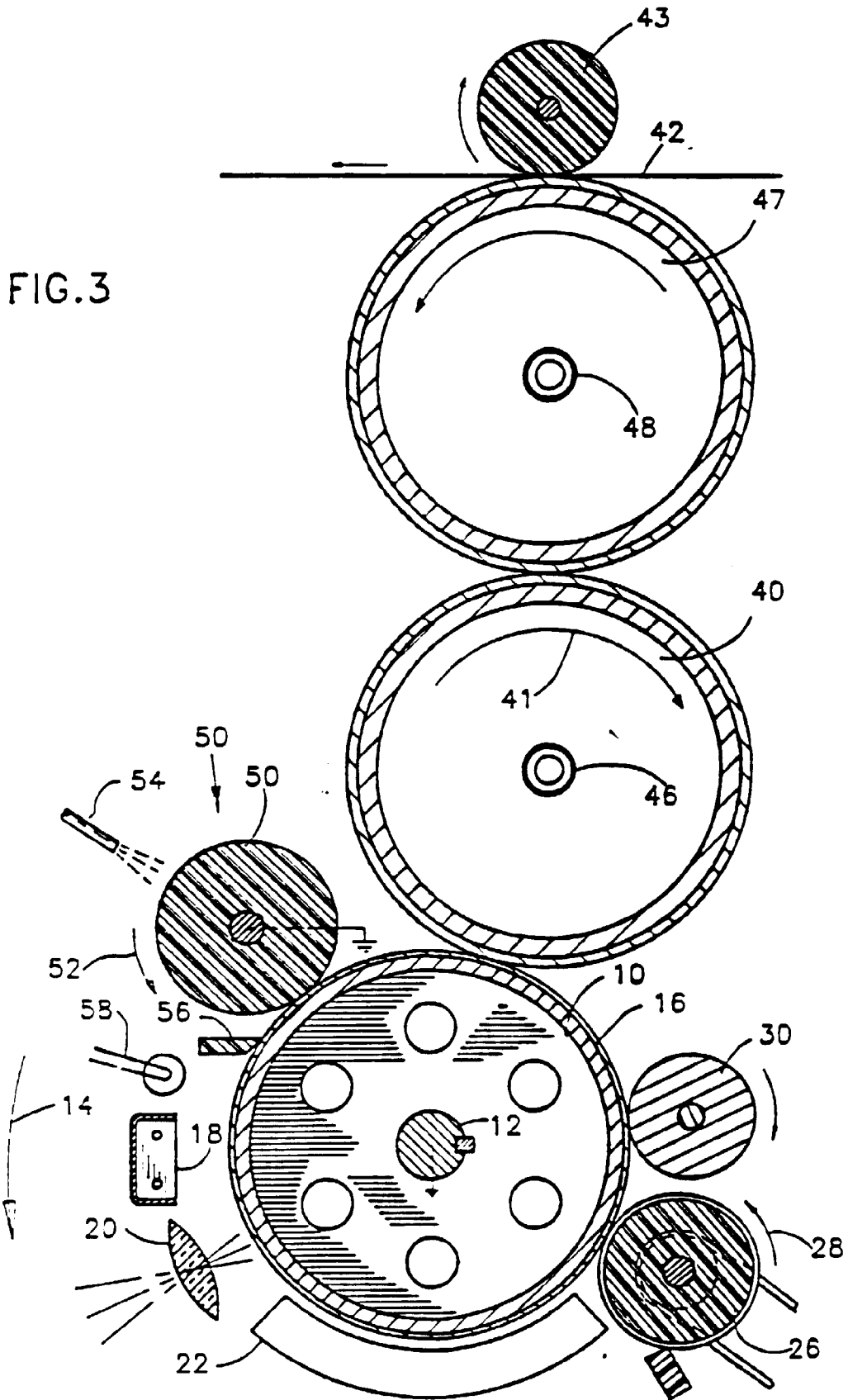

FIG. 4

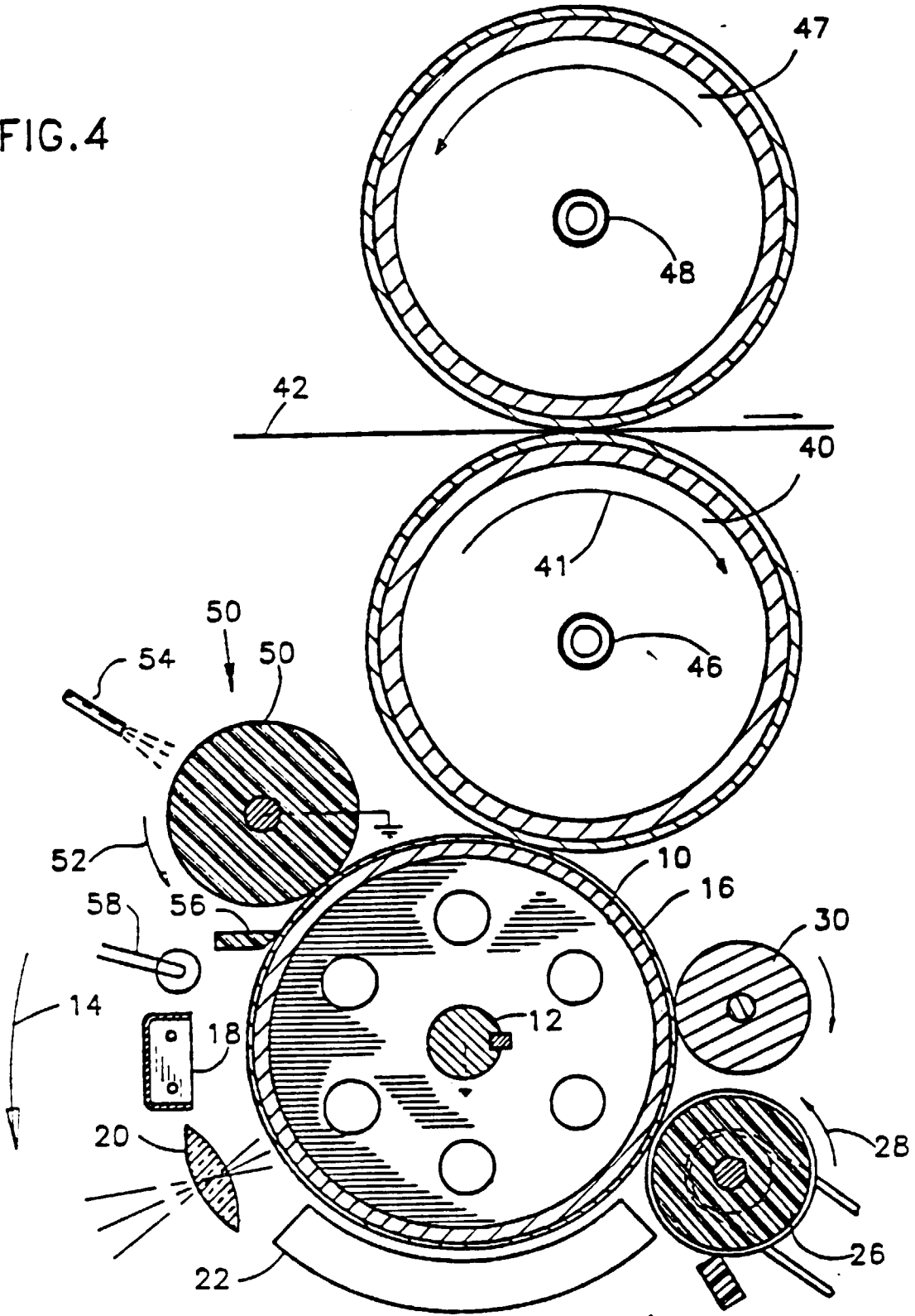
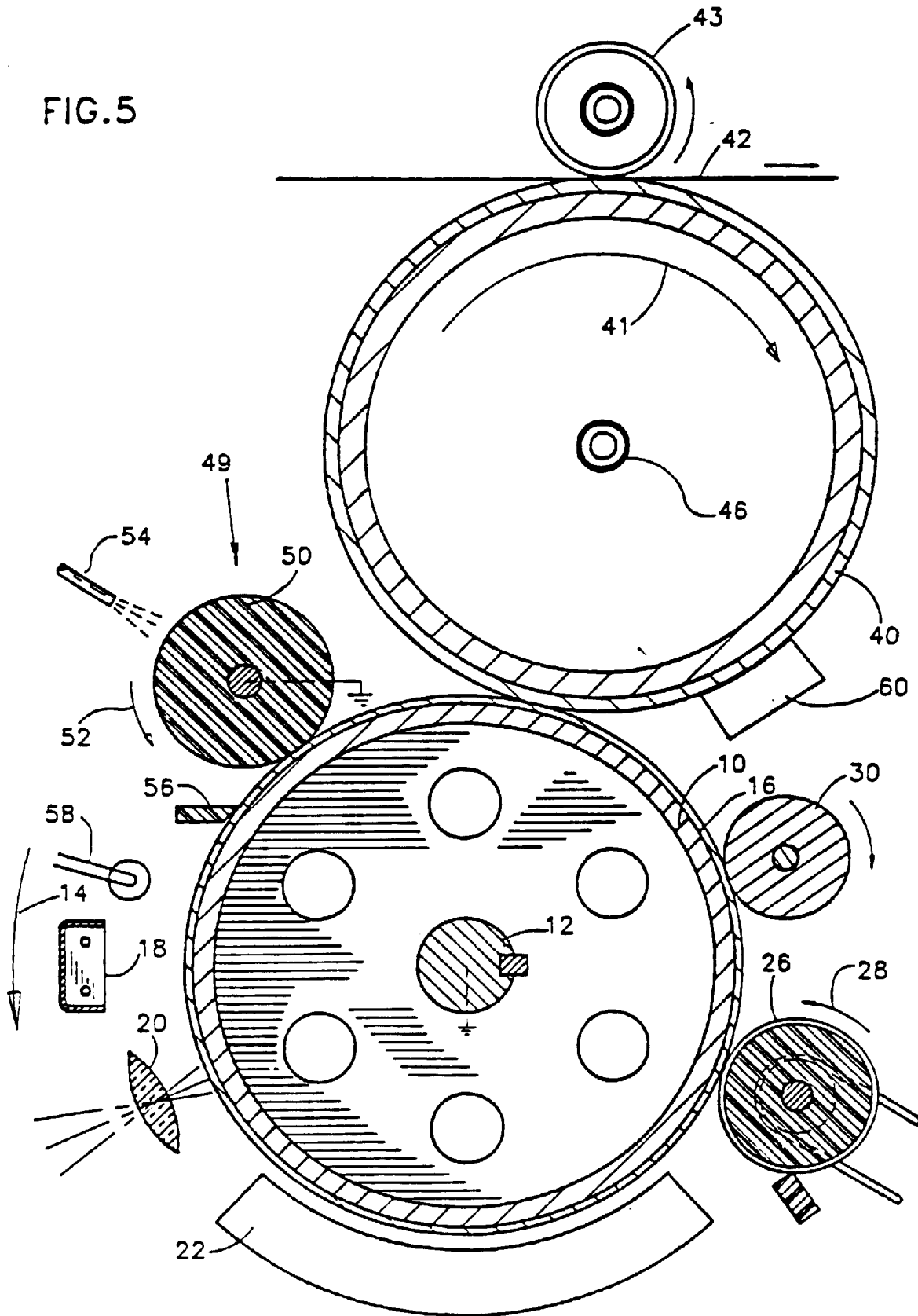

FIG. 5



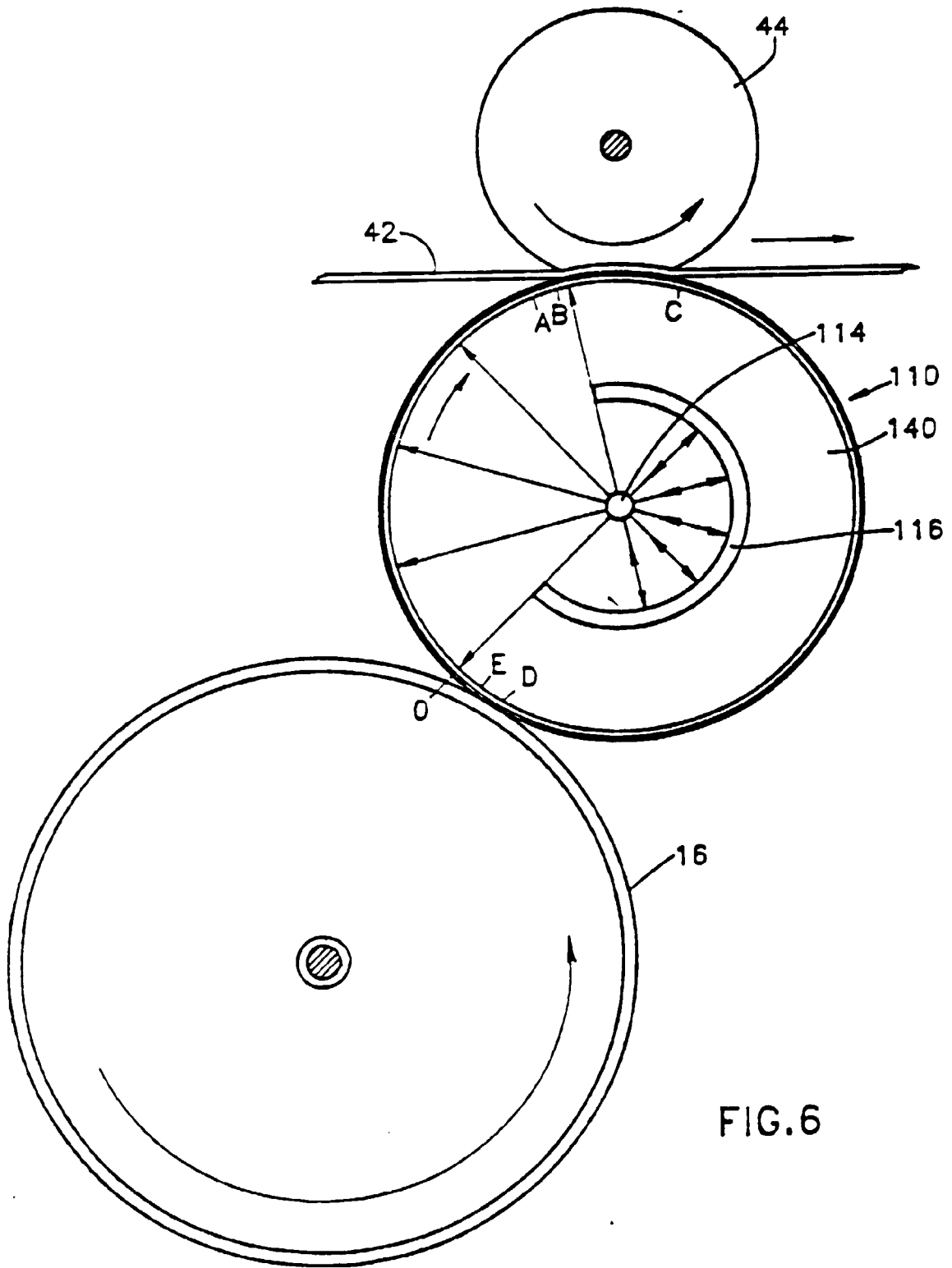

FIG.6

FIG.7

