



(19) **United States**

(12) **Patent Application Publication**
Gilman et al.

(10) **Pub. No.: US 2003/0110662 A1**

(43) **Pub. Date: Jun. 19, 2003**

(54) **ADHERENT ORTHOTIC PAD**

(52) **U.S. Cl.** 36/43; 36/140; 36/71; 36/93

(76) Inventors: **Thomas H. Gilman**, Spring Grove, IL (US); **Christopher T. Glaeser**, Grayslake, IL (US)

(57) **ABSTRACT**

An orthotic pad is disclosed for reducing pressure and shear stresses on dermal and muscle tissue in treatment areas extending over bony prominences. This pad includes a hydrocolloid-containing adhesive body having oppositely-facing non-parallel first, and second major surfaces. The pad is formed of a soft, deformable and shape-recoverable adhesive material in which particles of at least one moisture-absorbing and moisture-swelling hydrocolloid material are dispersed. The first surface of the pad is contoured to match that of the treatment area for adhesively engaging and covering such area, and the second surface has a developed shape for corrective redistribution of external forces exertable against the treatment area to prevent further damage from pressure or shear forces, promote the healing process and, in appropriate cases, provide orthopedic correction.

Correspondence Address:
MARSHALL, GERSTEIN & BORUN
6300 SEARS TOWER
233 SOUTH WACKER
CHICAGO, IL 60606-6357 (US)

(21) Appl. No.: **10/022,466**

(22) Filed: **Dec. 13, 2001**

Publication Classification

(51) **Int. Cl.⁷** **A43B 13/38; A43B 23/00**

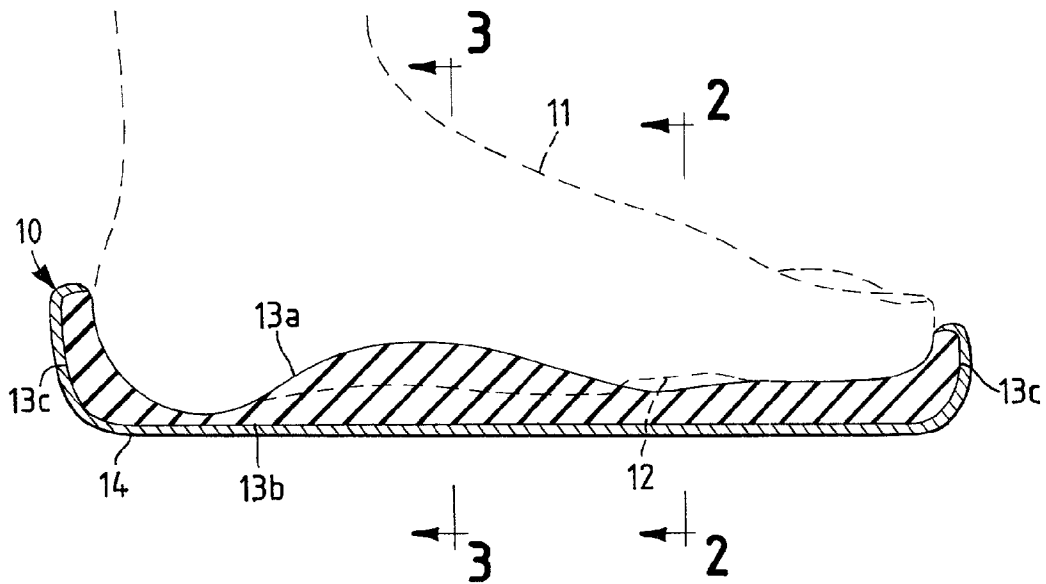

FIG. 1

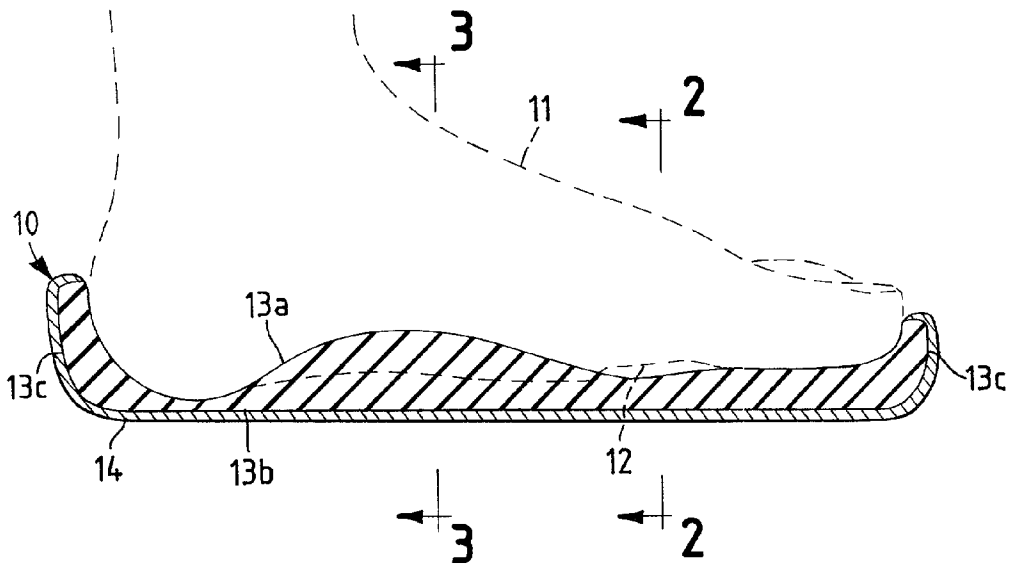

FIG. 2

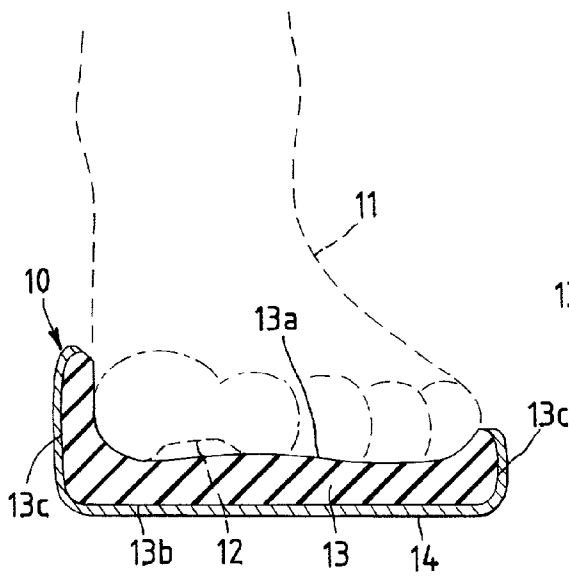
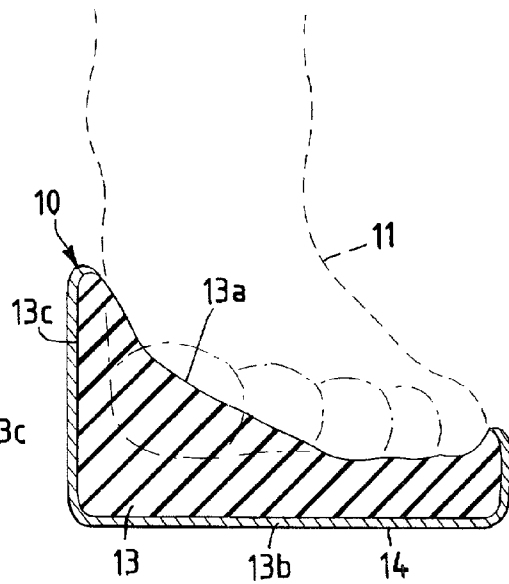

FIG. 3



ADHERENT ORTHOTIC PAD**BACKGROUND AND SUMMARY OF THE INVENTION**

[0001] Pressure ulcers are areas of skin death caused by excessive pressure or shear, either one of which will close off the flow of blood in the skin vessels. In general, the risk of tissue death is increased with higher levels of pressure or shear stress, and with longer duration of the pressure or shear insult.

[0002] Bony prominences are concentrators of pressure, and so skin over these areas on the body is especially at risk to pressure injury. Such areas where bone is not padded much by muscle also can be areas where high shear stresses in the skin are encountered, as a person sits, lies, or stands on a surface.

[0003] In healthy individuals, the body is constantly repositioned so as to relieve areas of excessive pressure and shear. Even in sleep, an individual senses the need to reposition the body to relieve pressure and shear, and does so many times throughout the night.

[0004] Certain individuals are impaired in their ability to either sense the need to reposition, or in their ability to do so. For example, an individual who is recovering from hip surgery may feel the need to move to another position as he/she lies bed, but may be unable to do so. Other individuals may be so critically ill that they are not aware of the need to reposition their bodies to relieve areas of the skin circulation that are compromised by pressure or shear stresses. Such patients are especially prone to developing ulcers in the sacrum, coccyx, and heel areas.

[0005] An extreme case is the individual that has no sensation in the skin at all, such as a paraplegic. These people cannot feel the skin that is in contact with a chair's surface, and so are very likely to develop pressure ulcers on the skin where they sit every day. They simply have no way of knowing when it is necessary to reposition themselves, or to know when the repositioning was effective. Such patients often develop pressure ulcers over the ischium.

[0006] Diabetic individuals have this same problem with their feet. Their disease results in peripheral neuropathy, where the nerves of the feet no longer function. Since their sensory nerves are not functioning, they cannot know when pressure or shear has become excessive in their feet. An object in the shoe that is causing a pressure ulcer is unnoticed. Excessive pressure over a metatarsal bone is unnoticed. Shear due to a certain pattern of walking, or due to an unfavorable shoe fit, is unnoticed.

[0007] The motor neurons in the feet of diabetics are also affected by the disease, and this can lead to muscle deformities. These muscle problems will alter the structure of the foot, so the foot is positioned in an abnormal way during walking. This leads to areas of the skin that see abnormally high pressure and shear as the person walks. The muscle abnormalities can also lead to an altered gait, or way of walking, so that both feet are affected by an abnormality developed in one foot.

[0008] To deal with these problems, diabetics are often given custom orthotics in the form of relatively rigid shoe inserts that are made to match the surface of the bottom of

the foot on one side. The other side of the orthotic is designed to contact the shoe surface in such a way as to help correct for the foot deformity and resulting gait abnormality. Using the orthotic in the shoe helps to normalize the way pressure and shear are distributed on the foot during walking. However, such custom orthotics are neither adhesive nor absorbent. As a result, the orthotics may easily become misaligned with the bottom of the foot to which they are custom designed to fit, thereby potentially compounding the problem.

[0009] Diabetics seem to be especially sensitive to shear damage. Their blood vessels are more fragile than those of normal individuals, so shear stress can cause bruising more easily in diabetics. This is a problem in the foot, because shear is a normal part of the walking process.

[0010] Once a pressure ulcer has developed, treatment will fail unless the pressure and shear issues are resolved. For example, in diabetics, if an ulcer is present on the plantar surface of the foot, this ulcer will not heal unless measures are taken to ensure that toe ulcer area is protected from pressure and shear damage during walking. Even very brief episodes of excessive pressure or shear can damage the very fragile tissue, and set the healing process back. It is not practical to ask a patient to refrain completely from walking for the months required to heal an ulcer. Orthotics can help, but even an evening trip to the bathroom in bare feet can cause significant damage to the wound site.

[0011] One strategy that has been tried with success in these situations is the total contact cast. A doctor encloses the foot in a plaster cast designed so that walking will not result in further damage to the wound area. This is, in a sense, an orthotic that is always in place, and in fact cannot be removed except by the doctor. There are some disadvantages to the total contact cast, however. One cannot reach the wound for dressing changes. One cannot inspect the wound, and the skin around the wound, for developing problems. The cast itself can cause pressure points if it is not optimally applied, and again this cannot be detected without removing and then reapplying the cast. Applying the cast is a time consuming process that requires some skill.

[0012] An important aspect of this invention therefore lies in providing an orthotic device that is particularly effective in eliminating or reducing pressure and shear stresses on dermal and muscle tissues in treatment areas extending over bony prominences. The device takes the form of an adhesive absorbent pad with a body-contacting surface contoured to conform with the skin surface in the area of treatment and with an opposite surface of a different shape determined by the surfaces or objects to be engaged and the deformities if any to be corrected. Specifically, the pad includes an adhesive body or layer of a soft, deformable and shape-recoverable, pressure-sensitive adhesive material in which particles of at least one moisture-absorbing and moisture-swallowable hydrocolloid material are dispersed. The oppositely-facing major surfaces of the pad are non-parallel, with an adhesive body-facing first surface being contoured to match the shape of the treatment area and the oppositely-facing second surface having a developed shape for corrective redistribution of external forces directed against the area of treatment. The second surface of the adhesive body is covered by a tough, durable protective layer which may be either flexible or rigid and may, if desired, be extended to cover the side edge surfaces of the adhesive body as well.

[0013] Other features, objects and advantages of the invention will become apparent from the specification and drawings.

DRAWING

[0014] FIG. 1 is a longitudinal sectional view of an adhesive foot orthotic embodying this invention.

[0015] FIG. 2 is a vertical sectional view taken along line 2-2 of FIG. 1.

[0016] FIG. 3 is a sectional view taken along line 3-3 of FIG. 1.

DETAILED DESCRIPTION OF A PREFERRED EMBODIMENT OF THE INVENTION

[0017] Referring to the drawings, FIGS. 1-3 depict an adherent orthotic pad 10 for treatment of a foot 11, and particularly for protective treatment of a wound 12, such as a pressure ulcer, along the plantar surface of the foot extending over a bony prominence at the metatarsal joint. While a foot orthosis is illustrated, it is to be understood that the invention is not limited to an orthotic pad for treatment of the foot. The drawings show only one embodiment of the invention, but other embodiments may include adherent orthotic pads for treatment areas where dermal and muscle tissue have developed pressure ulcers such as, for example, the sacrum, coccyx, elbow, or any other part of the body exposed to pressure or shear insult resulting from the concentration and extended duration of external pressures producing circulatory insufficiencies and tissue death.

[0018] The pad comprises a hydrocolloid-containing adhesive body 13 and a protective outer covering 14. The body is formed entirely of a soft, deformable, pressure-sensitive, hydrocolloid-containing adhesive composition, commonly referred to as a skin barrier composition, that is generally non-flowable, retains its integrity upon hydration, and has shape-recovering properties. It must be capable of adhering to the skin for extended periods, but the adherence must not be so aggressive as to risk skin injury or irritation during use and at the time of removal. It should also have sufficiently high cohesive strength to resist disintegration throughout its duration of use and to remain intact at the time of removal so that little or no residue remains adhered to the skin.

[0019] Such adhesive skin barrier compositions are known for use in ostomy and wound care and typically comprise a discontinuous phase composed of particles of one or more hydrocolloids dispersed throughout a continuous water-insoluble elastomeric adhesive phase. Initial tack, usually referred to as dry tack, is provided by the continuous phase but, because such a barrier material is occlusive or non-breathable, adherence to the skin would be disrupted by perspiration if it were not for the dispersed hydrocolloids which absorb fluids and thereby maintain and possibly enhance adhesive attachment to the skin. U.S. Pat. Nos. 5,492,943 and 4,551,490 disclose suitable water-absorbing and swellable hydrocolloid gums including sodium carboxymethylcellulose, pectin, gelatin, guar gum, locust bean gum, gum karaya, and mixtures thereof. The elastomers used in the continuous phase commonly include polyisobutylenes, which may be either of relatively low viscosity average molecular weight (about 36,000 to about 58,000) or

of higher molecular weight (for example 750,000 to 2,350,000). The elastomer phase may also contain a styrene block co-polymer component to help provide extensibility and recovery from modular strains. While proportions may vary, such skin barrier compositions generally have a hydrocolloid content within the range of about 35% to 70% by weight of the total composition and an elastomeric adhesive phase in the range of about 20% to 40% of that total. In addition, such a composition may include hydrocarbon plasticizers consisting of petrolatum or mineral oil, and suitable tackifying and antioxidant agents. For more detailed information concerning such skin barrier compositions, reference may be had to the abovementioned patents, the disclosures of which are incorporated by reference herein.

[0020] A characteristic aspect of an orthotic pad embodying this invention lies in the fact that the two major surfaces of the adhesive body 13 are of different shape or contour and are non-parallel, resulting in a body of differing thickness or depth throughout its outline area. A first or body-facing surface 13a is shaped to match the contour of the body part to which the adhesive orthotic pad is to be adhered, whereas the second or outwardly facing surface 13b is of a different shape designed for corrective redistribution of external forces exertable against the body part. If the adherent pad takes the form of a foot orthotic as shown, then the second surface 13b may be substantially planar, matching that of a floor or other planar support surface upon which the patient's foot may be placed. However, in the case of a patient having foot deformities that tend to produce abnormally high pressure and shear areas when the patient stands and walks, the outwardly facing surface 13b of the pad may be of developed shaped to help correct defects in the patient's gait. By redistributing external forces applied to the foot so that localized areas of excessive pressure or shear over bony prominences are avoided, the formation of pressure ulcers in such areas may be prevented and the healing of ulcers in such areas may be promoted.

[0021] Protective layer 14, also referred to herein as a protective layer 14, or simply a covering 14, covers the outer surface 13b of the adhesive layer and matches the shape or contour of that surface. In a preferred embodiment, the protective layer or cover also extends upwardly about the side edges or surfaces 13c of the adhesive layer as shown in the drawings. Covering 14 may be formed of any tough and durable material capable of withstanding contact with external objects and surfaces, and the covering can be flexible or rigid. A tough flexible polymeric film, such as one formed of a polyolefin, is believed suitable, but other materials, such as fabrics of natural and synthetic fibers, may be used. The protective covering layer 14 is of generally uniform thickness throughout its full extent, but its outwardly-facing surface may be patterned or textured to prevent slipping and provide traction upon engagement with a support surface. Preferably, the protective layer 14 is rigid and textured for foot orthotics, and rigid and smooth for orthotic pads intended for use elsewhere on the body.

[0022] Any of a number of methods may be used to form the foot orthotic 10 so that its body-facing surface 13 matches the contour of the full treatment area which the orthotic is to adhesively engage—in this case, the entire underside of a patient's foot. Such methods include making a plaster cast of the foot, using that cast to make a positive mold, and then molding the body of skin barrier material

about one side of the positive mold. Other methods include using a laser scanner combined with 3D CAD software to develop a positive mold that duplicates the treatment surface to be protected and then using that mold to produce an orthotic in which a surface of the adhesive body matches the surface to which the orthotic is to be adhered. While the term "matching" is used to describe the contour of the body-facing surface of the adhesive pad or device, ordinarily where the body surface to be treated has a wound with a substantial depression or cavity **12**, the surface of the adhesive pad is formed to span that depression or cavity (as shown in **FIGS. 1 and 2**) rather than project into the wound.

[0023] While in the foregoing, an embodiment of the invention has been disclosed in detail for purposes of illustration, it will be understood by those skilled in the art that many of these details may be varied without departing from the spirit and scope of the invention.

1. An orthotic pad for reducing pressure and shear stresses on dermal and muscle tissue in a selected treatment area extending over a bony prominence, comprising a hydrocolloid-containing adhesive body having oppositely-facing non-parallel first and second major surfaces and comprising a soft, deformable and shape-recoverable adhesive material in which particles of at least one moisture-absorbing and moisture-swallowable hydrocolloid material are dispersed;

said first surface being contoured to match the contour of said treatment area for adhesively engaging and covering said area;

said second surface having a selected shape different than said contour of said first surface;

and a protective layer covering said second surface.

2. The orthotic pad of claim **1** in which said protective layer is of substantially uniform thickness and conforms with said surface shape of said second surface.

3. The orthotic pad of claims **1** or **2** in which said protective layer is flexible.

4. The orthotic pad of claims **1** or **2** in which said protective layer is rigid.

5. The orthotic pad of claims **1** or **2** in which said second surface is generally planar.

6. The orthotic pad of claims **1** or **2** in which said second surface is non-planar and of a developed shape for corrective redistribution of external forces exertable against said treatment area.

7. A foot orthotic for reducing pressure and shear stresses on dermal and muscle tissue in and about a wound area of treatment, comprising a hydrocolloid-containing adhesive body having oppositely facing non-parallel first and second major surfaces and comprising a soft, deformable and shape-recoverable adhesive material in which particles of at least one moisture-absorbing and moisture-swallowable hydrocolloid material are dispersed;

said first surface being contoured to match the contour of said treatment area for adhesively engaging covering said area;

said second surface having a selected shape different than said contour of said first surface;

and a protective layer covering said second surface.

8. The foot orthotic of claim **7** in which said protective layer is of said substantially uniform thickness and conforms with said surface shape of said second surface.

9. The foot orthotic of claims **7** or **8** in which said second surface is generally planar.

10. The foot orthotic of claims **7** or **8** in which said second surface is non-planar and of a developed shape for corrective redistribution of external forces exertable against said treatment area.

* * * * *