

[54] APPARATUS FOR CENTRIFUGAL HYDROEXTRACTION COMBINED WITH OILING OF TEXTILE PIRNS

[75] Inventors: Shigeo Kitamura; Takatugu Nakamoto; Toshihiro Kaziura; Shuichi Kurata, all of Osaka, Japan

[73] Assignee: Kanebo Ltd., Tokyo, Japan

[22] Filed: June 14, 1972

[21] Appl. No.: 262,479

[30] Foreign Application Priority Data

June 26, 1971 Japan..... 46/46487

[52] U.S. Cl. 68/150, 8/155.1

[51] Int. Cl. B05c 8/02

[58] Field of Search 68/150, 1; 8/155.1

[56] References Cited

UNITED STATES PATENTS

1,564,503 12/1925 Wolfer..... 68/150

FOREIGN PATENTS OR APPLICATIONS

1,275,032 9/1961 France..... 68/150

Primary Examiner—William I. Price

Attorney—Allan Ratner

[57] ABSTRACT

Apparatus including a rotary upright spindle is placed within a chamber confined by an openable mantle casing in order to extract water or watery liquid from textile pirns mounted thereon by centrifugal effect caused by a high speed axial rotation thereof, subsequent rotation of the spindle at relatively lower speed in combination with a supply pump and a cross valve causing circulation of oiling agent through the textile pirns.

13 Claims, 4 Drawing Figures

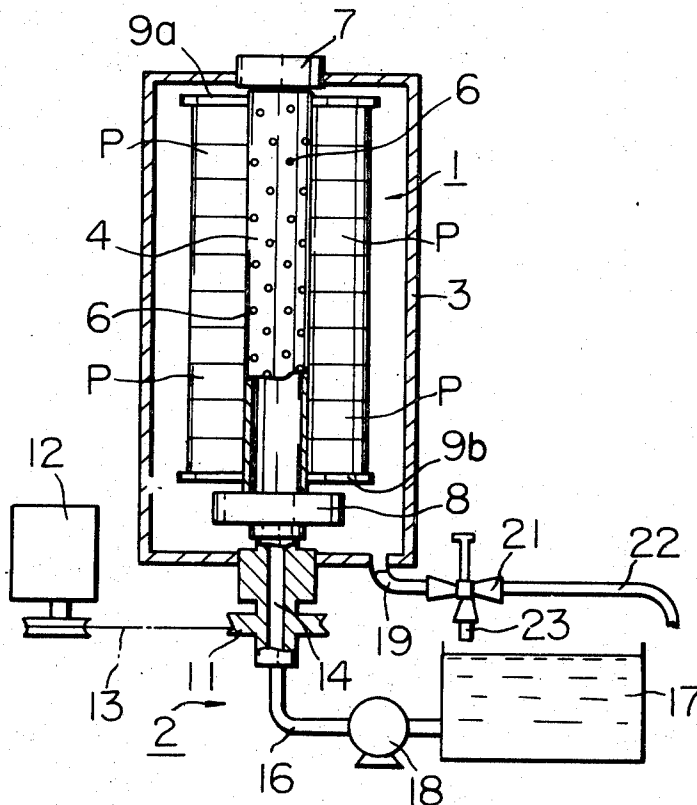

Fig. 1

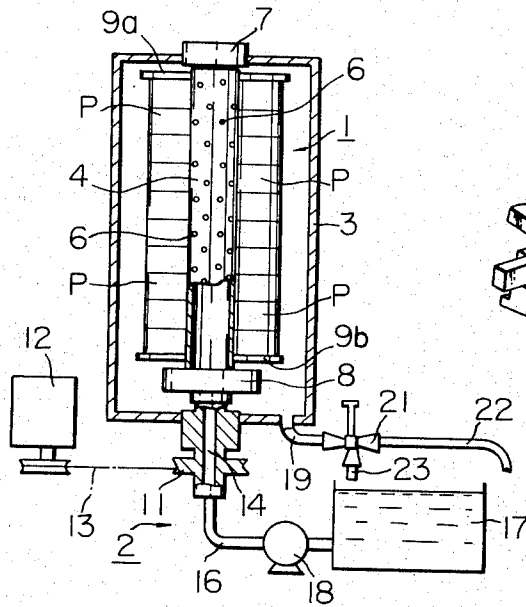

Fig. 3

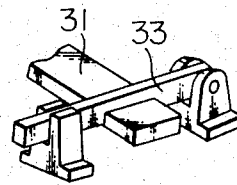
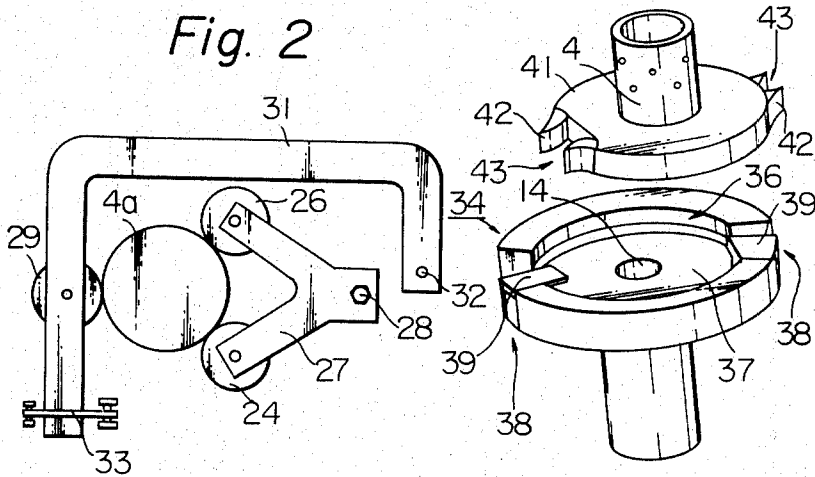

Fig. 4

Fig. 2



APPARATUS FOR CENTRIFUGAL HYDROEXTRACTION COMBINED WITH OILING OF TEXTILE PIRNS

The present invention relates to an improved apparatus for centrifugal hydroextraction combined with oiling of textile pirns, more particularly it relates to a centrifugal and vertical type apparatus whereon hydroextraction and subsequent oiling of textile pirns are carried out in direct succession utilizing axial rotation of a spindle bearing the textile pirns.

In the conventional system for dehydrating water or watery liquid off from textile pirns after dyeing, circulation of heated air through the pirns is employed so that water or watery liquid is removed from the interior of the pirns in a vaporized condition. When such vaporizing technique is utilized, removal of water or watery liquid can be desirably carried out with less or least damage on the shape of the pirns. However, such a system is accompanied by drawbacks such as high cost for installation and machine running, relatively long time necessary for one cycle operation and low efficiency in the operation. In addition, when hydroextraction is carried out in this system, a separate arrangement and separate operation are needed for oiling of textile pirns, which results in an increase in the manufacturing cost of the end products.

The object of the present invention is to provide an automatic apparatus of simple construction for effectively carrying out hydroextraction and subsequent oiling of textile pirns with reduced operational cost.

In order to attain this object, the apparatus includes an upright spindle mounted for an axial rotation in a chamber confined by a mantle casing. Centrifugal effect caused by the high speed rotation of the spindle drives water or watery liquid off from pirns mounted thereon. After completion of the hydroextraction, the spindle is rotated at a relatively lower speed and, thereby, the oiling agent supplied from a given oil bath is circulated through the bodies of the pirns for oiling of the pirns.

Further features, operations and advantages of the present invention may be made clearer from the ensuing description, reference being made to the accompanying drawings, in which;

FIG. 1 is a vertical plane view, partly in section, of a basic embodiment of the apparatus of the present invention,

FIG. 2 is a simplified top plane view of the upper carrier assembly used in the apparatus shown in FIG. 1,

FIG. 3 is a perspective plane view, partly omitted, of the part for locking the arrangement shown in FIG. 2,

FIG. 4 is a perspective plane view, partly omitted, of the lower carrier assembly and its related parts used in the apparatus shown in FIG. 1.

Referring to FIG. 1, an arrangement of a basic embodiment of the apparatus of the present invention is shown. The apparatus is comprised of two major functional parts, i.e. a hydroextractor part 1 and an oiling part 2 structurally combined with the former. The hydroextractor part 1 is spacedly contained within an upright cylindrical casing 3 and includes, as its major component, an upright spindle 4 which is cylindrical in shape and provided with numerous radial perforations 6. The spindle 4 is mounted for rotation between an upper carrier assembly 7 and a lower carrier assembly

8. Structure of both assemblies 7 and 8 will be further explained later on in more detail.

The spindle 4 is further provided with a pair of detachably mounted holder plates 9a and 9b which are vertically spaced from each other. In practical use, it is desirable that the holder plates 9a and 9b are so disposed to the spindle 4 that the spacing between them can be easily adjusted in accordance with the size and number of pirns to be inserted over the spindle 4 as later described.

The lower carrier assembly 8 is accompanied by a driven pulley 11 which is downwardly integral therewith and connected to a driver motor 12 for rotation of the spindle 4 via a belt 13. In practical use, it is desirable that electric motors of the speed variable type or speed shiftable type should be employed for this purpose.

A conduit 14, which directly communicates with the interior of the spindle 4, is formed almost vertically through the lower carrier assembly 8 and the driven pulley 11 and a pipe 16 leading to a given oil bath 17 via a supply pump 18 is connected to the downward opening of the conduit 14. Known sealing means for preventing accidental undesirable leakage of liquid is attached to the junction of the pipe 16 with the conduit 14.

Aside from this arrangement, the casing 3 is provided with a discharge pipe 19 which is communicated with the interior of the casing 3 through the bottom wall of same. The discharge pipe 19 is connected to a cross valve 21, located downstream, through which the extracted aqueous component, e.g. water and oily water, is discharged outside the system via a drain pipe 22 or into the oil bath 17 via another pipe 23, both pipes being connected to the cross valve 21.

The detail structure of the upper carrier assembly 7 is shown in FIG. 2, wherein a pair of freely rotatable contact rolls 24 and 26 are pivoted to ends of branches of a bracket 27 fixed to a stationary part of the assembly 7 by, for example, a set bolt 28. The rolls 24 and 26 are so mounted that they are placed in peripheral contact with the upper extension 4a of the spindle 4 when the latter is in position within the casing 3. On a side opposite to the rolls 24 and 26 with respect to the extension 4a, another contact roll 29 is carried, for free axial rotation, by a swingable arm 31 which is pivoted to a pin 32 fixed to the stationary part of the assembly 7. When the arm 31 comes to a position whereat the roll 29 is placed in a peripheral contact with the upper extension 4a of the spindle 4, the arm 31 can be locked to the position by a locker-bar 33 operable on the free end of the arm 31. In the case of the illustrated embodiment, the locker-bar 33 is swingable vertically like a railway crossing bar (see FIG. 3) and the underside cut-out of the bar 33 closely engages the stem of the arm 31 so as to firmly register the roll 29 at the position for the contact with the upper extension. However, any other locking mechanism known to persons skilled in the art may be employed for this purpose in the apparatus of the present invention.

The structure of the lower carrier assembly 8 is shown in detail in FIG. 4, wherein a flange 34 is provided with a central hollow 36 the bottom of which is covered by an elastic layer 37 leaving a center opening for the conduit 14 (see FIG. 1). The flange 34 is further provided with a pair of cut-outs 38 formed through the annular wall defining the central hollow 36. In each

cut-out 38, an L-shaped member 39 is disposed in an arrangement somewhat projecting into the central hollow 36, and the directions of the horizontal branches of the L-shaped members 39 in the respective cut-outs 38 are similar to each other along the peripheral direction of the flange 34.

On the other hand, the spindle 4 is provided with a circular disc 41 which can be received inside the central hollow 36 of the flange 34 when the spindle 4 is mounted on the lower carrier assembly 8. The disc 41 is provided with radial projections 42 for defining cut-outs 43 corresponding to the L-shaped members 39 of the flange 34. The dimension of the projections 42 is so selected that, when the disc 41 is pressed downward and combined with the flange 34, the projections 42 can be accommodated within gaps between the horizontal branches of the L-shaped member 39 and the bottom elastic layer 37.

At the time of the spindle mounting, the spindle 4 is mounted onto the flange 34 in such a manner that the cutouts 43 of the bottom disc 41 coincide the corresponding cutouts 38 of the flange 34. Next, locking of the upper carrier assembly 7 is performed as already explained in relation to FIGS. 2 and 3. Finally, the drive motor 12 (see FIG. 1) is energized for rotation of the flange 34 via elements 13 and 11 whereby, because the disc 41 with the spindle 4 does not instantly follow this rotation due to inertia, the radial projections 42 are compulsively received in the above-described gaps between the L-shaped members 39 and the bottom elastic layer 37. This compulsory insertion of the projections 42 into the gaps strongly presses the elastic layer 37 against the bottom face of the central hollow 36 resulting in an enhanced sealing effect during the oiling operation.

The hydroextraction and oiling of the pirns are carried out in the following sequence on the apparatus of the present invention having the above-described structural features.

After washing out in the dyeing operation, pirns P containing water or watery liquid are brought to the apparatus of the present invention and inserted over the spindle 4. After the prescribed number of wet pirns are mounted, the upper holder plate 9a is fixed in position, the upper carrier assembly 7 is locked as already explained and the drive motor 12 is switched on. At this stage of the operation, the cross valve 21 is so settled that the discharge pipe 19 is communicated with the drain pipe 22 but not with the pipe 23. The supply pump 18 is left inoperative.

By initial rotation of the drive motor 12, the spindle 4 now carrying the pirns P is wedged to the lower carrier assembly 8 as already explained in relation to FIG. 4. By further high speed rotation of the spindle 4 with pirns P, water or watery liquid contained in the pirns P is urged to move towards the periphery of the pirns P and, finally, is purged off from the pirns P towards the inner wall of the casing 3 due to the centrifugal force caused by the high speed rotation of the pirns P with the spindle 4. That is, the pirns are centrifugally dehydrated on the apparatus of the present invention. Water or watery liquid so extracted flows downwards towards the bottom of the casing 3 along the side wall thereof and is discharged from the system via the elements 19, 21 and 22.

It was experimentally confirmed by the inventors of the present invention that, when the spindle 4 was ro-

tated for 5 min at a speed of about 2,500 RPM, a pirn of hydrophobic yarn could be dehydrated to such an extent that the resultant moisture content of the pirn was lower than 10 percent. Further enhanced dehydrating effect can be obtained by escalation of the rotation speed of the spindle or by elongation of the operation time for the centrifugal rotation.

When there is no need of oiling the pirns, they may be dismounted from the apparatus of the present invention for next stage of operation after completion of the hydroextraction. However, in general, oiling of the pirns is desirably carried out subsequent to this hydroextraction.

For the oiling operation, the drive motor 12 is shifted to the low speed side, the cross valve 21 is so settled as to join the discharge pipe 19 with the pipe 23 but not with the drain pipe 22 and the supply pump 18 is started for operation. By this activation of the supply pump 18, the oiling agent in the oil bath 17 is transported into the cylindrical spindle 4 via the pipe 16 and the conduit 14, the oiling agent so introduced into the spindle 4 gradually permeates into the configuration of the pirns and moves outwards towards the periphery of the pirns due to the centrifugal force caused by the spindle rotation. The oiling agent so fed to the pirns is collected into the discharge pipe 19 as in the case of the hydroextraction and returned into the oil bath 17 via the elements 21 and 23 for the next recycling.

In one experiment conducted by the inventors of the present invention, after completion of the hydroextraction, the spindle was rotated for 5 min at 500 RPM speed with a pump exit pressure of 0.5 kg/cm². Next in succession, the pump was stopped and the spindle was further rotated for 10 min at 2,500 RPM speed. With the pirns so oiled, it was confirmed that there were no appreciable variances in the amount of oil both between pirns and within a pirn.

Through employment of the art of the present invention, hydroextraction and oiling of textile pirns can be carried out in considerably shortened time in a remarkably simplified process. Direct and successive combination of the oiling process with the dehydrating process greatly contributes to the desirable reduction in the manufacturing cost in the textile industry.

Although it is not illustrated in the drawing, the casing 3 for confining the chamber for accommodating the hydroextractor part is naturally provided with a detachable or openable surface part through which the pirns P can be brought into or taken out of the chamber in the usual manner.

What is claimed is:

1. An improved apparatus for centrifugal hydroextraction combined with oiling of textile pirns comprising, in combination, a stationary and openable hollow casing defining a chamber; an upright cylindrical spindle disposed, for axial rotation, within said chamber and provided with numerous radial perforations formed through the shell thereof; an upper carrier assembly mounted to the top of said casing and clamping the upper end part of said spindle; a lower carrier assembly disposed to the bottom of said casing and bearing said spindle for said axial rotation; means for mounting pirns on said spindle in a superimposed disposition; means for causing said axial rotation of said spindle and connected to said lower carrier assembly; means for discharging water or watery liquid off from said chamber; and means for circulating oil through

the interior of said spindle, said perforations of said spindle, said chamber and said discharging means.

2. An improved apparatus as claimed in claim 1 wherein said upper carrier assembly includes, in combination, a bracket fixed to a stationary part of the framework of the apparatus, one or more contact rolls pivoted to said bracket in an arrangement peripherally contactable with said spindle upper end part, a swingable arm pivoted to said stationary framework part at its one end and pivotally carrying at least one contact roll peripherally contactable with said spindle upper end part and means for locking said swingable arm to a position wherein said contact rolls cooperatively clamp said spindle upper end part.

3. An improved apparatus as claimed in claim 2 wherein said locking means includes a locker bar extending across said swingable arm and vertically turnable about a fixed pivot on its end and said locker bar restricts free swinging of said swingable arm in its lowered disposition.

4. An improved apparatus as claimed in claim 1 wherein said spindle is provided with a disc fixed to the bottom thereof, said lower carrier assembly includes a flange rotated by said rotation causing means and having a central hollow receptive of said bottom disc of said spindle and said disc is firmly joined with said flange by a means for wedging the two elements.

5. An improved apparatus as claimed in claim 4 wherein said wedging means includes one or more radial projections formed on the periphery of said disc and a corresponding number of L-shaped members disposed to cut-outs formed radially through the annular wall confining the central hollow of said flange, said L-shaped members slightly protruding into said central hollow.

6. An improved apparatus as claimed in claim 4 wherein the bottom of said central hollow of said flange is partly covered by an elastic surface.

7. An improved apparatus as claimed in claim 1 wherein said pin mounting means includes a pair of vertically spaced holder plates, the upper one being removably inserted over said spindle in a vertically adjustable arrangement and the lower one being fixedly inserted over said spindle.

8. An improved apparatus as claimed in claim 1 wherein said rotation causing means includes a drive motor, a driven pulley integral with a rotary part of said lower carrier assembly and a belt or the like for connecting said drive motor with said driven pulley.

9. An improved apparatus as claimed in claim 8 wherein said drive motor is of a speed variable type.

10. An improved apparatus as claimed in claim 8 wherein said drive motor is of a speed shiftable type.

11. An improved apparatus as claimed in claim 1 wherein said discharging means includes a discharge pipe opening at the bottom of said chamber and a drain pipe connected to this discharge pipe.

12. An improved apparatus as claimed in claim 1 wherein said compulsory oil circulating means includes an oil bath, a pipe leading from this oil bath to a conduit formed through said rotation causing means and lower carrier assembly opening into the interior of said spindle, a supply pump disposed to this pipe and a cross valve disposed to said discharging means and introducing the oiling water discharged from said chamber into said oil bath during the oiling process.

13. An improved apparatus as claimed in claim 12 further comprising means for sealing the junction of said pipe with said conduit.

* * * * *

40

45

50

55

60

65