



- (51) International Patent Classification:  
H02P 21/14 (2006.01)
- (21) International Application Number:  
PCT/US2014/047735
- (22) International Filing Date:  
23 July 2014 (23.07.2014)
- (25) Filing Language: English
- (26) Publication Language: English
- (30) Priority Data:  
13/948,330 23 July 2013 (23.07.2013) US
- (71) Applicant: **ATIEVA, INC.** [US/US]; 1100 Island Drive, Suite 103, Redwood City, California 94065 (US).
- (72) Inventor: **TANG, Yifan**; 1100 Island Drive, Suite 103, Redwood City, California 94065 (US).
- (74) Agent: **GENCARELLA, Michael**; Womble Carlyle Sandridge & Rice LLP, PO Box 7037, Atlanta, Georgia 30357 (US).
- (81) Designated States (unless otherwise indicated, for every kind of national protection available): AE, AG, AL, AM, AO, AT, AU, AZ, BA, BB, BG, BH, BN, BR, BW, BY, BZ, CA, CH, CL, CN, CO, CR, CU, CZ, DE, DK, DM, DO, DZ, EC, EE, EG, ES, FI, GB, GD, GE, GH, GM, GT, HN, HR, HU, ID, IL, IN, IR, IS, JP, KE, KG, KN, KP, KR, KZ, LA, LC, LK, LR, LS, LT, LU, LY, MA, MD, ME,

MG, MK, MN, MW, MX, MY, MZ, NA, NG, NI, NO, NZ, OM, PA, PE, PG, PH, PL, PT, QA, RO, RS, RU, RW, SA, SC, SD, SE, SG, SK, SL, SM, ST, SV, SY, TH, TJ, TM, TN, TR, TT, TZ, UA, UG, US, UZ, VC, VN, ZA, ZM, ZW.

- (84) Designated States (unless otherwise indicated, for every kind of regional protection available): ARIPO (BW, GH, GM, KE, LR, LS, MW, MZ, NA, RW, SD, SL, SZ, TZ, UG, ZM, ZW), Eurasian (AM, AZ, BY, KG, KZ, RU, TJ, TM), European (AL, AT, BE, BG, CH, CY, CZ, DE, DK, EE, ES, FI, FR, GB, GR, HR, HU, IE, IS, IT, LT, LU, LV, MC, MK, MT, NL, NO, PL, PT, RO, RS, SE, SI, SK, SM, TR), OAPI (BF, BJ, CF, CG, CI, CM, GA, GN, GQ, GW, KM, ML, MR, NE, SN, TD, TG).

**Declarations under Rule 4.17:**

- as to applicant's entitlement to apply for and be granted a patent (Rule 4.17(ii))
- as to the applicant's entitlement to claim the priority of the earlier application (Rule 4.17(iii))

**Published:**

- with international search report (Art. 21(3))
- before the expiration of the time limit for amending the claims and to be republished in the event of receipt of amendments (Rule 48.2(h))

(54) Title: INDUCTION MOTOR FLUX AND TORQUE CONTROL WITH ROTOR FLUX ESTIMATION

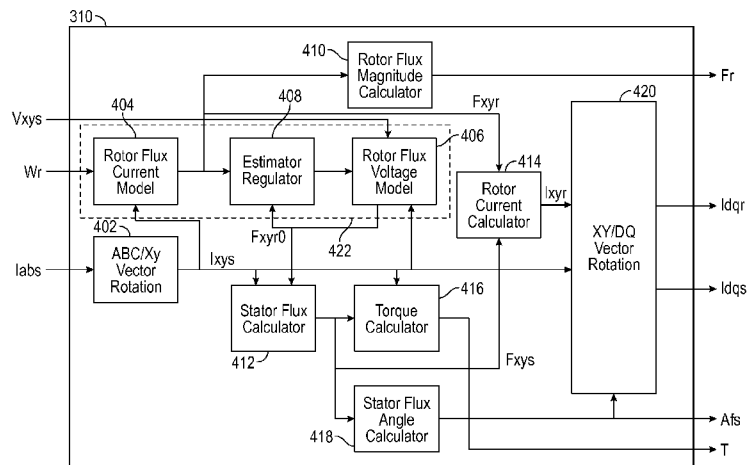

FIG. 4

(57) Abstract: A rotor flux estimator is provided. The rotor flux estimator includes an estimation module that generates a first rotor flux vector expressed in a phase voltage reference frame and a second rotor flux vector expressed in the phase voltage reference frame, from a stator voltage vector expressed in a phase voltage reference frame, a rotational speed of a rotor, and a stator current vector expressed in the phase voltage reference frame. The estimation module includes at least one processor and the estimation module includes a rotor flux current model and a rotor flux voltage model.

WO 2015/013361 A1

# INDUCTION MOTOR FLUX AND TORQUE CONTROL WITH ROTOR FLUX ESTIMATION

## BACKGROUND

5 [0001] In an induction motor, AC (alternating current) electrical power energizes windings of a stator, creating a rotating magnetic field that is characterized as having a stator flux. The stator flux induces electric current in windings of the rotor. The rotor experiences a torque, and rotates under load at a rate that is slower than the rotation speed of the stator flux. The difference between the rotation rate of the rotor and the rotation rate of the stator  
10 flux is the slip speed, and the difference between positions of the rotor and the stator flux is called the slip angle. The changing flux that the rotor sees as a result of difference in rotation speed from the stator flux is called the rotor flux.

[0002] Two popular types of induction motor controllers, and the algorithms which these use, are direct torque control (DTC) and field oriented control (FOC). In DTC, torque and  
15 stator flux are controlled using coordinates in a stator alpha and beta reference frame, i.e. coordinates relative to the a and b phases of the stator, with calculations in a stationary coordinate system. In FOC, rotor flux, torque current quadrature component and rotor flux direct component are controlled using coordinates in a rotor d and q reference frame, i.e.  
20 coordinates relative to the direct and quadrature axes of the rotor, with calculations in a rotating coordinate system that rotates synchronously with the rotor. Each type of induction motor controller has advantages and disadvantages. Therefore, there is a need in the art for a solution which overcomes the drawbacks of the systems described above.

## SUMMARY

25 [0003] In some embodiments, a rotor flux estimator is provided. The rotor flux estimator includes an estimation module that generates a first rotor flux vector expressed in a phase voltage reference frame and a second rotor flux vector expressed in the phase voltage reference frame, from a stator voltage vector expressed in a phase voltage reference frame, a rotational speed of a rotor, and a stator current vector expressed in the phase voltage  
30 reference frame. The estimation module includes at least one processor and the estimation module includes a rotor flux current model and a rotor flux voltage model.

[0004] In some embodiments, a rotor flux estimator is provided. The rotor flux estimator includes a first module that generates, via application of a rotor flux current model, a first rotor flux vector expressed in a phase voltage reference frame from a stator current vector expressed in the phase voltage reference frame and a rotational speed of a rotor. The rotor flux estimator includes a second module that generates, via application of a rotor flux voltage model, a second rotor flux vector expressed in the phase voltage reference frame from a stator voltage vector expressed in the phase voltage reference frame, the stator current vector expressed in the phase voltage reference frame, and an estimation correction factor. The rotor flux estimator includes an estimator regulator that generates the estimation correction factor from the first rotor flux vector expressed in the phase voltage reference frame and the second rotor flux vector expressed in the phase voltage reference frame, wherein at least the first module, the second module, or the estimator regulator, includes a processor.

[0005] In some embodiments, a method of estimating rotor flux is provided. The method includes producing a first rotor flux vector, expressed in a phase voltage reference frame, from a stator current vector expressed in the phase voltage reference frame and a rotational speed of a rotor, via application of a rotor flux current model. The method includes producing a second rotor flux vector, expressed in the phase voltage reference frame, from the stator current vector expressed in the phase voltage reference frame, a stator voltage vector expressed in the phase voltage reference frame, and an estimation correction factor, via application of a rotor flux voltage model. The method includes producing the estimation correction factor from a difference between the first rotor flux vector and the second rotor flux vector, wherein at least one method operation is executed through a processor.

[0006] Other aspects and advantages of the embodiments will become apparent from the following detailed description taken in conjunction with the accompanying drawings which illustrate, by way of example, the principles of the described embodiments.

## BRIEF DESCRIPTION OF THE DRAWINGS

[0007] The described embodiments and the advantages thereof may best be understood by reference to the following description taken in conjunction with the accompanying drawings. These drawings in no way limit any changes in form and detail that may be made to the described embodiments by one skilled in the art without departing from the spirit and scope of the described embodiments.

[0008] Fig. 1 is a schematic diagram of an induction motor controller in accordance with the present invention.

[0009] Fig. 2 is a vector diagram illustrating direct and quadrature (d and q) axes of a stator flux reference frame rotating with respect to x and y axes of a phase voltage reference frame, as referred to in the schematic diagram of Fig. 1.

[0010] Fig. 3 is a schematic diagram of an embodiment of the induction motor controller of Fig. 1.

[0011] Fig. 4 is a schematic diagram of an embodiment of the flux and torque estimator of Fig. 3.

10 [0012] Fig. 5 is a schematic diagram of an embodiment of the flux and torque limiter of Fig. 3.

[0013] Fig. 6 is a schematic diagram of an embodiment of the torque regulator of Figs. 1 and 3.

15 [0014] Fig. 7 is a schematic diagram of an embodiment of the flux regulator of Figs. 1 and 3.

[0015] Fig. 8 is a flow diagram of a method of estimating rotor flux, which can be practiced on embodiments of the induction motor controller of Figs. 1 and 3-7.

## DETAILED DESCRIPTION

20 [0016] An induction motor controller, embodiments of which are shown in Figs. 1-8 and described herein, has features and operation that differ from field oriented control (FOC) and direct torque control (DTC) induction motor controllers. The present induction motor controller performs rotor flux and torque control with a rotor flux regulator loop and a torque regulator loop, and operates in a stator flux reference frame and a phase voltage reference  
25 frame. The rotor flux and torque regulator loops are processed (at least partially) in the stator flux reference frame. This contrasts with DTC, which controls torque and stator flux, and performs calculations in a static (i.e., nonrotating) reference frame, and contrasts with FOC, which performs calculations in a reference frame aligned to the specific flux under control, among other differences. Controlling rotor flux as a regulated variable in a stator flux  
30 reference frame, in the present system, contrasts with other systems and methods which

control rotor flux as a regulated variable in a rotor flux reference frame or which control stator flux as a regulated variable in a stator flux reference frame. Embodiments of the present induction motor controller can operate without current regulation loops, in contrast with FOC controllers many (or all) of which require current control.

5 [0017] A torque regulator and a flux regulator, in the present induction motor controller, generate a commanded stator voltage vector, which is expressed in the stator flux reference frame. This vector is rotated and transformed to a vector in the phase voltage reference frame, from which AC (alternating current) power to the induction motor is derived. Additional modules provide feedback for the torque regulator loop and the rotor flux  
10 regulator loop, as will be further described below.

[0018] Detailed illustrative embodiments are disclosed herein. However, specific functional details disclosed herein are merely representative for purposes of describing embodiments. Embodiments may, however, be embodied in many alternate forms and should not be construed as limited to only the embodiments set forth herein.

15 [0019] It should be understood that although the terms first, second, etc. may be used herein to describe steps or calculations, these steps or calculations should not be limited by these terms. These terms are only used to distinguish one step or calculation from another. For example, a first calculation could be termed a second calculation, and, similarly, a second step could be termed a first step, without departing from the scope of this disclosure. As used  
20 herein, the term “and/or” and the “/” symbol includes any and all combinations of one or more of the associated listed items.

[0020] As used herein, the singular forms “a”, “an” and “the” are intended to include the plural forms as well, unless the context clearly indicates otherwise. It will be further understood that the terms “comprises”, “comprising”, “includes”, and/or “including”, when  
25 used herein, specify the presence of stated features, integers, steps, operations, elements, and/or components, but do not preclude the presence or addition of one or more other features, integers, steps, operations, elements, components, and/or groups thereof. Therefore, the terminology used herein is for the purpose of describing particular embodiments only and is not intended to be limiting.

30 [0021] It should also be noted that in some alternative implementations, the functions/acts noted may occur out of the order noted in the figures. For example, two figures shown in

succession may in fact be executed substantially concurrently or may sometimes be executed in the reverse order, depending upon the functionality/acts involved.

[0022] Fig. 1 shows an induction motor controller that operates in the stator flux reference frame and the phase voltage reference frame. The induction motor controller provides AC (alternating current) electrical power to an induction motor 106, for example three-phase electrical power to a three-phase induction motor. A torque regulator 108 operates a torque regulator loop 116, and uses this to generate a commanded stator voltage vector as projected onto the quadrature (q) axis in the stator flux reference frame, which vector projection or component is denoted  $V_{qsc}$ . A rotor flux regulator 110 operates a rotor flux regulator loop 114, and uses this to generate the commanded stator voltage vector as projected onto the direct (d) axis in the stator flux reference frame, which vector projection or component is denoted  $V_{dsc}$ . The stator flux reference frame 102 will be further discussed regarding Fig. 2. Quantities in the stator flux reference frame 102 are identified as “dq” if a vector, or “d” if a direct component of a vector and “q” if a quadrature component of a vector.

[0023] Thus, the torque regulator 108 and the rotor flux regulator 110 together generate the commanded stator voltage vector  $V_{dsc}$ ,  $V_{qsc}$ , expressed in the stator flux reference frame 102. Both the torque regulator 108 and the rotor flux regulator 110 operate in the stator flux reference frame 102. In the embodiment shown, the torque regulator 108 and flux regulator 110 are separate modules, but could be combined into a larger module. The commanded stator voltage vector  $V_{dsc}$ ,  $V_{qsc}$  represents the stator voltage that is commanded by the induction motor controller, as determined in order to regulate the torque and the rotor flux of the induction motor 106. The DQ/XY coordinate transformation module 112 transforms the commanded stator voltage vector  $V_{dsc}$ ,  $V_{qsc}$  from the stator flux reference frame 102 to the phase voltage reference frame 104, where the transformed vector  $V_{xsc}$ ,  $V_{ysc}$  is used to generate the AC power for the induction motor 106. In the embodiment shown, the induction motor 106 is a three-phase induction motor. The three phases are denoted a, b, c. Other numbers of phases and other denotations for the phases could be used.

[0024] Fig. 2 functions as a guide to understanding the reference frames, vectors, projections and embodiments of the induction motor controller as described herein. In Fig. 2, the x and y axes are orthogonal. The x and y axes are in the phase voltage reference frame. The x axis is aligned with one of the phase voltages of the stator of the induction motor, for example the phase voltage of the “A” winding of the stator. As AC power is applied to the

stator windings, the stator flux linkage (i.e., the total magnetic flux linked by the stator windings) rotates relative to the phase voltage reference frame. This is depicted in the vector diagram as the d or direct axis rotating at a rotational speed or rotational rate of  $\omega_s$ , the rotational speed of the stator flux. As is a common practice in the art, the term stator flux linkage is abbreviated to stator flux. The q or quadrature axis is perpendicular to the d axis. The q and d axes rotate together, which is symbolic of the stator flux reference frame rotating relative to the phase voltage reference frame. At any instant in time, the d axis is aligned with the stator flux and is angularly displaced from the x axis by a stator flux angle, denoted  $\theta_s$ . Equivalently, the stator flux angle  $\theta_s$  is the angle between the stator flux d axis and the x axis. At any instant in time, any vector quantity in either the stator flux space or the phase voltage space can be projected onto any of the axes. In the example shown, the rotor current, denoted  $i_r$ , is projected onto the d axis and onto the q axis.

[0025] In Fig. 3, an embodiment of the induction motor controller of Fig. 1 is further developed. The induction motor controller of Fig. 3 is intended for use in an electric or hybrid vehicle, which is propelled by the induction motor 106. Further embodiments of the induction motor controller could be used in other applications of induction motors besides vehicles, for example in industrial applications, electromechanical machines and robotics. An overview of the modules, operation and control loops of the induction motor controller is presented below, then followed by a more in-depth discussion of these. It should be appreciated that the various variables, coefficients, intermediate values, inputs and outputs can be adjusted for dimensional compatibility or normalized, depending upon implementation, and that in various embodiments, modules may be combined or split, or modules may contain additional modules.

[0026] A vehicle control unit 318, a torque command generator 316, and a flux command generator 314 cooperate to produce a commanded torque  $T_c$  and a commanded rotor flux  $F_{rc}$ . Generally, in an electric or hybrid vehicle, the commanded torque is based on input from a user, e.g., a driver of the electric vehicle or operator of an electromechanical device. More specifically, the commanded torque would be based on position of an accelerator pedal and position of a brake pedal in the vehicle. These would be based on other inputs in other systems.

[0027] The commanded torque  $T_c$  and the commanded rotor flux  $F_{rc}$  are input, along with loop variables, to the torque regulator 108 and the flux regulator 110. The torque regulator 108 and the flux regulator 110 together derive a commanded stator voltage vector,

expressed in the stator flux reference frame, via a rotor flux regulator loop 114 and a torque regulator loop 116. The rotor flux regulator loop 114 and the torque regulator loop 116 process at least partially in the stator flux reference frame.

[0028] A DQ/XY vector rotation module 302, a space vector modulation module 304,  
5 and a DC/AC (direct current to alternating current) inverter 306 process the commanded stator voltage vector to produce AC (alternating current) power for the induction motor 106. The DQ/XY vector rotation module 302, which is one embodiment of the DQ/XY coordinate transformation module 112 of Fig. 1, transforms the commanded stator voltage vector from the stator flux reference frame 102 (as  $V_{dsc}$ ,  $V_{qsc}$ ) to the phase voltage reference frame 104  
10 (as  $V_{xsc}$ ,  $V_{ysc}$ ), applying vector rotation according to the stator flux angle  $A_{fs}$ . The stator flux angle  $A_{fs}$  is estimated rather than sensed, and is generated in the flux and torque estimator 310.

[0029] The space vector modulation module 304 module generates pulse width modulation (PWM) switching controls for the DC/AC inverter 306 from the commanded  
15 stator voltage vector  $V_{xsc}$ ,  $V_{ysc}$  as transformed to the phase voltage reference frame 104. The DC/AC inverter 306 generates three-phase AC power for the induction motor 106 from the pulse width modulation switching controls received from the space vector modulation module 304. In a further embodiment, the DC/AC inverter 306 generates other numbers of phases for the AC power for the induction motor 106, depending upon the design for the  
20 inverter 306 and the induction motor 106.

[0030] The flux and torque estimator 310 produces an estimated torque  $T$ , the estimated stator flux angle  $A_{fs}$ , an estimated rotor flux magnitude  $F_r$ , an estimated stator current vector  $I_{dqs}$  expressed in the stator flux reference frame 102, and an estimated rotor current vector  $I_{dqr}$  expressed in the stator flux reference frame 102. It produces these from a stator voltage  
25 vector  $V_{xys}$  expressed in the phase voltage reference frame 104, a stator current  $I_{abs}$  of at least two phases, and a rotational speed  $W_r$  of the rotor of the induction motor. In the embodiment shown, the rotational speed  $W_r$  of the rotor is provided by a sensor such as a sensor associated with the induction motor 106. For example, the sensor could include or be part of a shaft encoder, a tachometer, a speedometer or other sensing device or assembly.  
30 The stator current could be provided as showing current in all three phases of the induction motor 106. However, as is well-known, providing values of the current of two phases allows deduction of the current in the third phase in a three-phase induction motor, since the vectors for these three currents add up to zero (with no net electrical charge buildup in, or loss from,

the motor). In one embodiment, the stator current  $I_{abs}$  is provided by sensors, i.e. is a measured value.

[0031] The estimated rotor flux magnitude  $F_r$  is coupled from the flux and torque estimator 310 to the flux regulator 110. The estimated torque  $T$  is coupled from the flux and torque estimator 310 to the torque regulator 108. The estimated stator flux angle  $A_{fs}$  is coupled from the flux and torque estimator 310 to the DQ/XY vector rotation module 302. The stator voltage vector  $V_{xys}$  expressed in the phase voltage reference frame 104 is produced by the space vector modulation module 304 from the commanded stator voltage vector  $V_{dsc}$ ,  $V_{qsc}$  expressed in the stator flux reference frame 102. The stator current  $I_{abs}$  of at least two phases is provided by the DC/AC inverter 306 and is coupled as an input to the flux and torque estimator 310.

[0032] In one embodiment, which will be further discussed regarding Fig. 4, the flux and torque estimator 310 applies a rotor flux current model and a rotor flux voltage model to generate the estimated rotor flux magnitude  $F_r$  and the estimated torque  $T$ . Referring back to Fig. 1, the rotor flux regulator loop 114 includes the estimated rotor flux magnitude  $F_r$  as an input to the flux regulator 110, and the torque regulator loop 116 includes the estimated torque  $T$  as an input to the torque regulator 108.

[0033] Continuing with Fig. 3, the flux and torque limiter 312 works with the flux command generator 314, the torque command generator 316 and the vehicle control unit 318. These modules cooperate to generate the commanded torque  $T_c$  and the commanded rotor flux  $F_{rc}$ , limiting the commanded torque  $T_c$  to less than or equal to a variable maximum commanded torque  $T_{cmax}$  and limiting the commanded rotor flux to greater than or equal to a variable minimum commanded rotor flux  $F_{rcmin}$  and less than or equal to a variable maximum commanded rotor flux  $F_{rcmax}$ . The commanded torque  $T_c$  is coupled from the torque command generator 316 as an input to the torque regulator 108. The commanded rotor flux  $F_{rc}$  is coupled from the flux command generator 314 as an input to both the torque regulator 108 and the flux regulator 110. An embodiment of the flux and torque limiter 312 will be further discussed regarding Fig. 5.

[0034] The discussion of the induction motor controller of Fig. 3 begins with the vehicle control unit 318 and proceeds clockwise (in the diagram) around the rotor flux regulator loop and the torque regulator loop. Conceptually, at high level, a command for torque of the induction motor 106 is given by a user through the vehicle control unit 318. The command

for torque is interpreted in terms of the state of the induction motor 106, more specifically in terms of the estimated rotor flux  $F_r$  and the estimated torque  $T$  of the induction motor 106. From the commanded torque  $T_c$ , the commanded rotor flux  $F_{rc}$  is derived, and these are used for calculations or processing in the stator flux reference frame 102. After transformation  
5 from the stator flux reference frame 102 to the phase voltage reference frame 104, AC power for the induction motor 106 is generated. Variables are fed back through the rotor flux regulator loop and the torque regulator loop and used in the calculations or processing in the stator flux reference frame 102, completing the loops. The various modules could be produced as hardware, software, firmware, or combinations thereof in various embodiments.  
10 For example, in one embodiment, one or more of the modules is implemented using software in a digital signal processor (DSP). Embodiments can include one or more processors, or combinations of one or more processors and hardware.

[0035] The vehicle control unit 318 produces an initial commanded torque  $T_{c0}$ , based upon user input. In one embodiment, the commanded torque  $T_{c0}$  is mapped from sensors  
15 coupled to the throttle and brake pedals of a vehicle. In further embodiments, the commanded torque  $T_{c0}$  is calculated, derived, or mapped from other sensors or modules. For example, an increased commanded torque  $T_{c0}$  is a result of a user requesting increased speed or acceleration of a vehicle, and a decreased commanded torque  $T_{c0}$  is a result of a user requesting decreased speed or acceleration of the vehicle. In some embodiments, the vehicle  
20 control unit applies hysteresis in mapping to the commanded torque  $T_{c0}$ .

[0036] The torque command generator 316 generates the commanded torque  $T_c$  from a variable maximum commanded torque  $T_{cmax}$  and the initial commanded torque  $T_{c0}$ . The variable maximum commanded torque  $T_{cmax}$  is applied to the initial commanded torque  $T_{c0}$  as a torque limit. This operation could be performed by a comparison and a mapping, which  
25 sends the initial commanded torque  $T_{c0}$  through as the commanded torque  $T_c$ , unless the initial commanded torque  $T_{c0}$  exceeds the variable maximum commanded torque  $T_{cmax}$ , in which case the variable maximum commanded torque  $T_{cmax}$  is sent through as the commanded torque  $T_c$ . In various embodiments, the torque command generator 316 runs at the same sampling rate as the main loop sampling rate, or a slower sampling rate as compared  
30 to the main loop sampling rate.

[0037] The flux command generator 314 generates the commanded rotor flux  $F_{rc}$  from the variable minimum commanded rotor flux  $F_{rcmin}$ , the variable maximum commanded rotor flux  $F_{rcmax}$ , the commanded torque  $T_c$  and the rotational speed  $W_r$  of the rotor. The

variable minimum commanded rotor flux  $F_{rmin}$  and the variable maximum commanded rotor flux  $F_{rmax}$  are applied to the commanded rotor flux  $F_{rc}$  as flux limits. In one embodiment, the flux command generator 314 generates an initial commanded rotor flux from the commanded torque  $T_c$ , using the relationship that the product of the rotational speed  $W_r$  of the rotor times the rotor flux is the back EMF (electromotive force), which is directly related to torque. It is possible for an induction motor to produce a same given torque by operating with a range of different rotor flux, where different rotor flux results in different operating performance of the motor such as different operating efficiency or different rotor electrical power loss. Through real-time calculation or table lookup operation, from the commanded torque  $T_c$  the initial commanded rotor flux  $F_{rc}$  can be obtained which optimizes a certain aspect of system operation (such as optimal motor efficiency). A comparison of the initial commanded rotor flux to the flux limits is then performed. The initial commanded rotor flux is sent through as the commanded rotor flux  $F_{rc}$ , unless the initial commanded rotor flux is less than the variable minimum commanded rotor flux  $F_{rmin}$ , in which case the variable minimum commanded rotor flux  $F_{rmin}$  is sent through as the commanded rotor flux  $F_{rc}$ . If the initial commanded rotor flux is greater than the variable maximum commanded rotor flux  $F_{rmax}$ , the variable maximum commanded rotor flux  $F_{rmax}$ , is sent through as the commanded rotor flux  $F_{rc}$ . In various embodiments, the flux command generator 314 runs at the same sampling rate as the main loop sampling rate, or a slower sampling rate as compared to the main loop sampling rate.

**[0038]** The torque regulator 108 processes a portion of the torque regulator loop and produces the projection of the commanded stator voltage vector  $V_{qsc}$  onto the quadrature axis in the stator flux reference frame 102. The torque regulator 108 processes in the stator flux reference frame 102. Specifically, the torque regulator 108 processes the commanded torque  $T_c$ , the estimated torque  $T$ , the commanded rotor flux  $F_{rc}$ , and the rotational speed  $W_r$  of the rotor of the induction motor 106, to produce the commanded stator voltage  $V_{qsc}$  as projected onto the quadrature axis in the stator flux reference frame 102. In one embodiment, the torque regulator 108 includes a PI (proportional-integral) controller. An embodiment of the torque regulator 108 will be further discussed with reference to Fig. 6.

**[0039]** The rotor flux regulator 110 processes a portion of the rotor flux regulator loop and produces a projection of the commanded stator voltage vector  $V_{dsc}$  onto the direct axis in the stator flux reference frame 102. The rotor flux regulator 110 processes in the stator flux reference frame 102. Specifically, the rotor flux regulator 110 processes the commanded

rotor flux  $F_{rc}$  and an estimated rotor flux magnitude  $F_r$ , to produce the commanded stator voltage  $V_{dsc}$  as projected onto the direct axis in the stator flux reference frame 102.

[0040] The DQ/XY vector rotation module 302 acts as a stator flux reference frame 102 to phase voltage reference frame 104 vector rotation module that applies the estimated stator flux angle  $A_{fs}$  to the commanded stator voltage vector  $V_{dsc}$ ,  $V_{qsc}$  as expressed in the stator flux reference frame 102. This application of the estimated stator flux angle  $A_{fs}$  transforms the commanded stator voltage, as projected onto the direct axis and the quadrature axis, from a first vector  $V_{dsc}$ ,  $V_{qsc}$  (i.e., the commanded stator voltage vector) in the stator flux reference frame 102 to a second vector  $V_{xsc}$ ,  $V_{ysc}$  (i.e., the commanded stator voltage vector) in the phase voltage reference frame 104. In one embodiment, this coordinate transformation applies an inverse Clarke transformation. In various embodiments, the coordinate transformation is performed using real-time calculation or a lookup table.

[0041] The space vector modulation module 304 generates pulse width modulation (PWM) switching controls. Further, the space vector modulation module 304 generates the stator voltage vector  $V_{xys}$  expressed in the phase voltage reference frame, as used by the flux and torque estimator 310. It generates these from the commanded stator voltage received as the second vector  $V_{xsc}$ ,  $V_{ysc}$  from the DQ/XY vector rotation module 302. In one embodiment, the PWM switching controls are normalized. In various embodiments, the stator voltage vector  $V_{xys}$  expressed in the phase voltage reference frame 104 is generated by multiplying a power supply voltage measurement  $V_{dc}$  and the commanded stator voltage vector  $V_{xsc}$ ,  $V_{ysc}$  expressed in the phase voltage reference frame 104, or the stator voltage vector  $V_{xys}$  expressed in the phase voltage reference frame 104 is measured (e.g., with a sensor) or estimated.

[0042] The DC bus 308 provides the power supply voltage measurement  $V_{dc}$  from a sensor. The DC bus in one embodiment is coupled to batteries or cells of the electric vehicle, which provide the DC power to the DC/AC inverter 306. In one embodiment, a sensor measures the voltage measurement  $V_{dc}$  of the DC bus 308.

[0043] The DC/AC inverter 306 generates three-phase AC power for the induction motor 106 from the PWM switching controls received from the space vector modulation module 304. In one embodiment, a sensor measures the inverter temperature  $T_i$ , which is sent to the flux and torque limiter 312. In one embodiment, sensors measure stator current  $I_{abs}$  of at least two of the phases of the stator, and send this to the flux and torque estimator 310.

[0044] In the embodiment shown, the induction motor 106 is equipped with sensors. One sensor measures the motor temperature  $T_m$ , and sends this to the flux and torque limiter 312. One sensor measures the rotational speed  $W_r$  of the rotor, and sends this to the flux and torque estimator 310, the flux and torque limiter 312, and the flux command generator 314.

5 [0045] The flux and torque estimator 310 generates the estimated stator flux angle  $A_{fs}$  for the DQ/XY vector rotation module 302, the estimated rotor flux  $F_r$  for the flux regulator 110, the estimated torque for the torque regulator 108, and the stator current vector  $I_{dqs}$  expressed in the stator flux reference frame 102 and the rotor current vector  $I_{dqr}$  expressed in the stator flux reference frame 102 for the flux and torque limiter 312. One embodiment of the flux and torque estimator 310 employs two distinct rotor flux models, as will be discussed regarding Fig. 4.

[0046] The flux and torque limiter 312 generates the variable minimum commanded rotor flux  $F_{rmin}$ , the variable maximum commanded rotor flux  $F_{rmax}$ , and the variable maximum commanded torque  $T_{rmax}$ . It generates these from the stator current vector  $I_{dqs}$  expressed in the stator flux reference frame 102, the estimated rotor current vector  $I_{dqr}$  expressed in the stator flux reference frame 102, the inverter temperature  $T_i$ , the motor temperature  $T_m$ , the rotational speed  $W_r$  of the rotor, and the measured DC voltage  $V_{dc}$  of the DC bus 308. The torque limit, namely the variable maximum commanded torque  $T_{rmax}$ , is sent from the flux and torque limiter 312 to the torque command generator 316. The lower and upper rotor flux limits, namely the variable minimum commanded rotor flux  $F_{rmin}$  and the variable maximum commanded rotor flux  $F_{rmax}$ , are sent from the flux and torque limiter 312 to the flux command generator 314.

[0047] Thus, the rotor flux regulator loop 114 and the torque regulator loop 116 are closed via the flux and torque estimator 310, the flux regulator 110 and the torque regulator 108, with limits imposed via the flux and torque limiter 312, the flux command generator 314 and the torque command generator 316. In order to close the loops, allowing feedbacks to cross from the phase voltage reference frame 104 back to the stator flux reference frame 102, one embodiment of the flux and torque estimator 310 includes a phase voltage reference frame to stator flux reference frame vector rotation module that transforms current vectors from the phase voltage reference frame 104 to the stator flux reference frame 102. An embodiment of the flux and torque limiter 312 will be further discussed regarding Fig. 5.

[0048] Fig. 4 shows an embodiment of the flux and torque estimator 310. Modules in the flux and torque estimator 310 are implemented in software, hardware, firmware, and various combinations thereof in various embodiments. For example, a module could be implemented as a software module executing in a DSP or other processor. In various embodiments, the rotor flux current model 404, the rotor flux voltage model 406, the rotor flux magnitude calculator 410, the rotor current calculator 414, the stator flux calculator 412, the torque calculator 416 and the stator flux angle calculator 418 are each lookup-table-based or real-time-calculation-based.

[0049] The ABC/XY vector rotation module 402 acts as a stator phase current reference frame to phase voltage reference frame 104 vector rotation module that transforms a stator current  $I_{abs}$  of at least two phases to a stator current vector  $I_{xys}$  expressed in the phase voltage reference frame 104. In one embodiment, this is performed using a Park's transformation or variation thereof.

[0050] In the embodiment of the flux and torque estimator 310 shown in Fig. 4, two rotor flux models cooperate with a regulator to form estimates of rotor flux vectors. The rotor flux current model 404 converges more quickly than does the rotor flux voltage model 406. Combining the two rotor flux models improves accuracy of the system in a wide range of operating condition, i.e., over a wide range of motor speed and over a wide range of motor torque. Also, combining the two rotor flux models allows the various estimated result to be based on voltage, current and speed rather than just two out of three of these variables.

[0051] The rotor flux current model 404 generates a fast-convergence estimated rotor flux vector  $F_{xyr}$  expressed in the phase voltage reference frame 104. It generates this from the stator current vector  $I_{xys}$ , expressed in the phase voltage reference frame 104, and the rotational speed of the rotor  $W_r$ .

[0052] The rotor flux voltage model 406 generates a slow-convergence estimated rotor flux vector  $F_{xyr0}$  expressed in the phase voltage reference frame 104. It generates this from the stator voltage vector  $V_{xys}$  expressed in the phase voltage reference frame 104, the stator current vector  $I_{xys}$  expressed in the phase voltage reference frame 104, and an estimation correction factor.

[0053] The estimator regulator 408 generates the estimation correction factor from the fast-convergence estimated rotor flux vector  $F_{xyr}$  expressed in the phase voltage reference frame 104 and the slow-convergence estimated rotor flux vector  $F_{xyr0}$  expressed in the phase

voltage reference frame 104. In one embodiment, the estimator regulator 408 includes a PI (proportional-integral) controller. The PI controller could form an error term from the difference between the fast-convergence estimated rotor flux vector  $F_{xyr}$  expressed in the phase voltage reference frame 104 and the slow-convergence estimated rotor flux vector  $F_{xyr0}$  expressed in the phase voltage reference frame 104. This error term could then be sent to a proportional module and an integral module, the outputs of which are summed to form the estimation correction factor. A PI controller is described with reference to Fig. 6 and an embodiment of the torque regulator 108.

[0054] Continuing with Fig. 4, four calculators in the flux and torque estimator 310 could be implemented using the calculating facilities of a DSP or other processor, or a hardware multiplier, or one or more lookup tables. The calculators could share a facility or each have a respective calculating facility. The rotor flux magnitude calculator 410 generates the estimated rotor flux magnitude  $F_r$  from the fast-convergence estimated rotor flux vector  $F_{xyr0}$  expressed in the phase voltage reference frame 104. The stator flux calculator 412 generates an estimated stator flux vector  $F_{xys}$  expressed in the phase voltage reference frame 104 from the slow-convergence estimated rotor flux vector  $F_{xyr0}$  expressed in the phase voltage reference frame 104 and the stator current vector  $I_{xys}$  expressed in the phase voltage reference frame 104. In one embodiment, the stator flux calculator 412 includes a model of inductances for windings of the stator of the induction motor. The rotor current calculator 414 generates an estimated rotor current vector  $I_{xyr}$  expressed in the phase voltage reference frame 104 from the fast-convergence estimated rotor flux vector  $F_{xyr}$  expressed in the phase voltage reference frame 104 and the estimated stator flux vector  $F_{xys}$  expressed in the phase voltage reference frame 104. The torque calculator 416 generates the estimated torque  $T$  from the stator current vector  $I_{xys}$  expressed in the phase voltage reference frame 104 and the estimated stator flux vector  $F_{xys}$  expressed in the phase voltage reference frame 104. The stator flux angle calculator 418 generates the estimated stator flux angle  $A_{fs}$  from the estimated stator flux vector  $F_{xys}$  expressed in the phase voltage reference frame 104.

[0055] The XY/DQ vector rotation module 420 acts as a phase voltage reference frame 104 to stator flux reference frame 102 vector rotation module that generates the estimated rotor current vector  $I_{dqr}$  expressed in the stator flux reference frame 102 and the stator current vector  $I_{dqS}$  expressed in the stator flux reference frame 102. It generates these from the estimated rotor current vector  $I_{xyr}$  expressed in the phase voltage reference frame 104, the stator current vector  $I_{xys}$  expressed in the phase voltage reference frame 104, and the

estimated stator flux angle  $A_{fs}$ . In one embodiment, the XY/DQ vector rotation module 420 employs a Clarke transformation.

[0056] Fig. 5 shows one embodiment of the flux and torque limiter 312. Some of the modules and the flux and torque limiter 312 have a calculator, which could be implemented similarly to the calculators in the flux and torque estimator 310. Modules in the flux and torque limiter 312 are implemented in software, hardware, firmware, and various combinations thereof in various embodiments. In various embodiments, each of the rotor current limiter, the field weakener, the stator current limiter, the low rotor flux limiter, the high rotor flux limiter, the stator-based torque limiter, and the rotor-based torque limiter is lookup-table-based or real-time-calculation-based. In various embodiments, the flux and torque limiter 312 runs at the same sampling rate as the main loop sampling rate, or a slower sampling rate as compared to the main loop sampling rate.

[0057] The rotor current limiter 502 generates a variable maximum rotor current  $I_{rmax}$  from the rotational speed  $W_r$  of the rotor, the estimated rotor current vector  $I_{dqr}$  expressed in the stator flux reference frame 102, and the motor temperature  $T_m$ . The motor temperature  $T_m$  is affected by the rotor current and the rotational speed  $W_r$  of the rotor. In one embodiment, the rotor current limiter 502 decreases the variable maximum rotor current  $I_{rmax}$  in response to an increased motor temperature  $T_m$ . This protects the rotor, and the induction motor 106, from overheating as a result of too much rotor current. In one embodiment, the rotor current limiter 502 includes a calculator.

[0058] The field weakener 504 generates a variable maximum stator flux  $F_{smax}$  from the rotational speed  $W_r$  of the rotor and the DC voltage  $V_{dc}$  of the DC bus 308 or other power source for the induction motor 106. In one embodiment, the field weakener 504 decreases the variable maximum stator flux  $F_{smax}$  in response to the rotational speed of the rotor  $W_r$  exceeding a base speed. The field weakener 504 further decreases the variable maximum stator flux  $F_{smax}$  in response to a decreasing DC voltage of the power source for the induction motor 106. Some motors become unstable for too high values of stator flux. For example, the induction motor could readily withstand a maximum stator flux up to a base speed of the motor, but become unstable at lesser values of stator flux for higher rotational speeds. In one embodiment, a lower DC voltage decreases the maximum available flux at higher RPMs of the rotor. As a further example, in some induction motors the maximum stator flux should be lowered for lower values of power supply voltage, past some base value of rotational speed of the rotor. Various maps are readily devised for the field weakener 504,

depending upon characteristics of a specified induction motor 106. In one embodiment, the field weakener 504 includes a calculator.

[0059] The stator current limiter 506 generates a variable maximum stator current  $I_{smax}$  from the rotational speed of the rotor  $W_r$ , the stator current vector  $I_{dq}$  expressed in the stator flux reference frame 102, and an inverter temperature  $T_i$ . The inverter temperature  $T_i$  is affected by the stator current and by the rotational speed of the rotor  $W_r$ . In one embodiment, the stator current limiter 506 decreases the variable maximum stator current  $I_{smax}$  in response to an increased inverter temperature  $T_i$ . This protects the stator and the induction motor 106 from overheating as a result of too high a stator current.

10 [0060] The low rotor flux limiter 508 generates a variable minimum commanded rotor flux  $F_{rmin}$  from the variable maximum rotor current  $I_{rmax}$  and the rotational speed of the rotor  $W_r$ . In one embodiment, the low rotor flux limiter 508 sets the variable minimum commanded rotor flux  $F_{rmin}$  consistent with readiness to accelerate the rotor. For example, because rotor current is induced in an induction motor, having too low a rotor flux results in a low rotor current, which will give slow responsiveness to commands to increase the torque of the induction motor. Another reason to set the variable minimum commanded rotor flux  $F_{rmin}$  is to maintain stability or robustness of the motor against sudden changes in shaft load as well as other disturbances. Setting a minimum commanded rotor flux prepares the induction motor to respond more quickly to a command to increase the torque and to maintain torque and speed despite disturbances. This minimum is dependent on motor design and also on operating situation, in some embodiments.

[0061] The high rotor flux limiter 510 generates the variable maximum commanded rotor flux  $F_{rmax}$  from the variable maximum stator flux  $F_{smax}$  and the variable maximum stator current  $I_{smax}$ . In one embodiment, the high rotor flux limiter 510 sets the variable maximum commanded rotor flux  $F_{rmax}$  based upon the variable maximum stator flux  $F_{smax}$  and the variable maximum stator current  $I_{smax}$ , so as to decrease the variable maximum commanded rotor flux  $F_{rmax}$  in response to either the variable maximum stator flux  $F_{smax}$  or the variable maximum stator current  $I_{smax}$  being decreased.

[0062] The stator-based torque limiter 512 generates a variable maximum stator-based commanded torque  $T_{cmax}$  from the variable maximum stator flux  $F_{smax}$  and the variable maximum stator current  $I_{smax}$ . In one embodiment, the stator-based torque limiter 512 sets the variable maximum stator-based commanded torque  $T_{cmax}$  based upon a product of the

variable maximum stator flux  $F_{smax}$  and the variable maximum stator current  $I_{smax}$ . In one embodiment, the stator-based torque limiter 512 includes a calculator.

[0063] The rotor-based torque limiter 514 generates a variable maximum rotor-based commanded torque  $T_{cmaxr}$  from the variable maximum rotor current  $I_{rmax}$  and the variable maximum commanded rotor flux  $F_{rcmax}$ . In one embodiment, the rotor-based torque limiter that sets the variable maximum rotor-based commanded torque  $T_{cmaxr}$  based upon a product of the variable maximum rotor current  $I_{rmax}$  and the variable maximum commanded rotor flux  $F_{rcmax}$ . In one embodiment, the rotor-based torque limiter 514 includes a calculator.

[0064] The final torque limiter 516 generates the variable maximum commanded torque  $T_{cmax}$  from the variable maximum rotor-based commanded torque  $T_{cmaxr}$  and the variable maximum stator-based commanded torque  $T_{cmaxs}$ . In one embodiment, the final torque limiter 516 sets the variable maximum commanded torque  $T_{cmax}$  by selecting the lesser of the variable maximum rotor-based commanded torque  $T_{cmaxr}$  and the variable maximum stator-based commanded torque  $T_{cmaxs}$ . For example, torque can be calculated by stator flux and stator current, or by rotor flux and rotor current. Comparing the two calculation results for torque and picking the lower one for a torque limit is a more conservative choice for stability purposes. In further embodiments, the greater of the two, an average of the two, or a weighted average of the two could be selected.

[0065] Fig. 6 shows an embodiment of the torque regulator 108 from Figs. 1 and 3. In this embodiment, the torque regulator 108 includes a proportional-integral (PI) controller 602. The PI controller 602 has a difference between the commanded torque  $T_c$  and the estimated torque  $T$  as an input. This difference, an error term in PI controller terminology, is shown as a summation 606 of the commanded torque  $T_c$ , as a positive input, and the estimated torque  $T$  as a negative input. The output of the summation 606 produces the torque error. The torque error is routed to a proportional module 614, which produces a factor that is proportional to the summation 606 output (i.e., proportional to the torque error), and an integral module 616, which produces a factor that is proportional to the integral of the summation 606 output (i.e., proportional to the integral of the torque error). The output of the proportional module 614 and the output of the integral module 616 are added by a summation 608 to produce the output of the PI controller 602.

[0066] In the embodiment shown in Fig. 6, the torque regulator 108 includes a feedforward module 604. The feedforward module 604 includes a summation 610 having as

inputs the output of the PI controller 602 and a product of the commanded rotor flux  $F_{rc}$  and the rotational speed of the rotor  $W_r$ . The feedforward summation 610 has as an output the commanded stator voltage  $V_{qsc}$  as projected onto the quadrature axis in the stator flux reference frame 102. In a further embodiment, the output summation 608 of the PI controller is combined with the feedforward summation 610 of the feedforward module 604, as a single summation with three inputs.

**[0067]** Fig. 7 shows an embodiment of the rotor flux regulator 110 from Figs. 1 and 3. In this embodiment, the rotor flux regulator 110 includes a proportional-integral-derivative (PID) controller 702 having as inputs the commanded rotor flux  $F_{rc}$  and the estimated rotor flux  $F_r$ , and having as an output the commanded stator voltage  $V_{dsc}$  projected onto the direct axis in the stator flux reference frame 102. The input summation 704 has the commanded rotor flux  $F_{rc}$  as a positive input and the estimated rotor flux  $F_r$  as a negative input. The output of the input summation 704 produces an error term, in PID controller terminology, in this case a flux error. The flux error is routed to a proportional module 708, which produces a term that is proportional to the summation 704 output (i.e., proportional to the flux error), an integral module 710, which produces a term that is proportional to the integral of the summation 704 output (i.e., proportional to the integral of the flux error), and a derivative module 712, which produces a term that is proportional to the derivative of the summation 704 output (i.e., proportional to the derivative of the flux error). The output of the proportional module 708, the output of the integral module 710, and the output of the derivative module 712, are added by an output summation 706 to produce the output of the PID controller 702, which is the commanded stator voltage  $V_{dsc}$  projected onto the direct axis in the stator flux reference frame 102.

**[0068]** Fig. 8 shows an embodiment of a method of estimating rotor flux. The method can be practiced on embodiments of the induction motor controller shown in Fig. 1 and Figs. 3-7. Particularly, the method can be practiced on the embodiment of the flux and torque estimator shown in Fig. 4, and variations thereof.

**[0069]** From a start point, a first rotor flux vector is generated, using a rotor flux current model, in an action 802. For example, the rotor flux current model of Fig. 4 could be used to generate the estimated rotor flux vector  $F_{xyr}$  expressed in the phase voltage reference frame, from the stator current vector  $I_{xys}$ , expressed in the phase voltage reference frame, and the rotational speed of the rotor  $W_r$ .

[0070] A second rotor flux vector is generated, using a rotor flux voltage model, in an action 804. For example, the rotor flux voltage model of Fig. 4 could be used to generate the estimated rotor flux vector  $F_{xyr0}$  expressed in the phase voltage reference frame, from the stator voltage vector  $V_{xys}$  expressed in the phase voltage reference frame, the stator current vector  $I_{xys}$  expressed in the phase voltage reference frame, and an estimation correction factor.

[0071] An estimation correction factor is generated, in an action 806. For example, the estimator regulator of Fig. 4 could be used to generate the estimation correction factor from the estimated rotor flux vector  $F_{xyr}$  expressed in the phase voltage reference frame and the estimated rotor flux vector  $F_{xyr0}$  expressed in the phase voltage reference frame. As a further example, a PI controller could be used to generate the estimation correction factor, as discussed above regarding the estimator regulator in Fig. 4. In one embodiment, the PI controller produces an integration of the difference between the first rotor flux vector and the second rotor flux vector. The PI controller sums a first term proportional to the difference between the first rotor flux vector and the second rotor flux vector, and a second term proportional to the integration of the difference between the first rotor flux vector and the second rotor flux vector. The estimation correction factor is produced as a result of the summing.

[0072] In an action 808, the estimation correction factor is applied to the generation of the second rotor flux vector. For example, the estimation correction factor could be included as an input to the rotor flux voltage model as shown in Fig. 4.

[0073] A rotor flux magnitude is generated, in an action 810. As an example, the rotor flux magnitude could be generated by the rotor flux magnitude calculator of Fig. 4, from the first rotor flux vector, i.e., the estimated rotor flux vector  $F_{xyr}$  expressed in the phase voltage reference frame.

[0074] A stator flux angle is generated, in an action 812. For example, the stator flux angle could be produced from the stator current vector  $I_{xys}$  expressed in the phase voltage reference frame and the second rotor flux vector  $F_{xyr0}$  expressed in the phase voltage reference frame, via the stator flux calculator and the stator flux angle calculator of Fig. 4.

[0075] A torque is generated, in an action 814. As an example, the torque could be produced from the stator current vector  $I_{xys}$  expressed in the phase voltage reference frame

and the second rotor flux vector  $F_{xyr0}$  expressed in the phase voltage reference frame, via the stator flux calculator and the torque calculator of Fig. 4.

[0076] A rotor current vector is generated, in an action 816. As an example, the estimated rotor current vector  $I_{xyr}$  expressed in the phase voltage reference frame could be produced from the first rotor flux vector  $F_{xyr}$  expressed in the phase voltage reference frame, the second rotor flux vector  $F_{xyr0}$  expressed in the phase voltage reference frame and the stator current vector  $I_{xys}$  expressed in the phase voltage reference frame, via the stator flux calculator and the rotor current calculator of Fig. 4. As a further example, the estimated rotor current vector  $I_{dqr}$  expressed in the stator flux reference frame could be produced from the estimated rotor current vector  $I_{xyr}$  expressed in the phase voltage reference frame, as produced above and rotated through the XY/DQ vector rotation module of Fig. 4.

[0077] After the action 816, an endpoint is reached. In variations, the method operates continuously, steps operate in parallel, or branching occurs, etc.

[0078] Various embodiments of the present induction motor controller, as described above with reference to Figs. 1-8, have some or all of the following characteristics and features. Rotor flux and torque control are performed with a rotor flux regulator loop and a torque regulator loop, without current regulation loops. The rotor flux and the torque regulator loops are processed in a stator flux reference frame. Quantities in the stator flux reference frame are identified as “dq”. Quantities in the stator stationary reference frame are identified as “xy”.

[0079] A flux and torque estimator is followed by a flux and torque limiter. The flux and torque estimator inputs are sensed motor phase currents, sensed or computed phase voltages, and sensed motor speed. The outputs are estimated rotor flux magnitude, torque magnitude, stator flux angle, and stator and rotor circuit currents in the “dq” reference frame. The stator flux angle, relative to the stator stationary frame, is used to perform vector rotation between “dq” and “xy”.

[0080] The flux and torque limiter runs in real-time at the same sampling rate (or slower sampling rate) compared to the main loop sampling rate. The flux and torque limiter determines a maximum torque command and a maximum and a minimum rotor flux magnitude. The basis of the design of this limiter block is a comprehensive motor physical model that defines the operating limits of the motor system as functions of battery bus voltage, sensed motor speed, and sensed inverter and motor operating temperatures.

[0081] One benefit of the flux and torque limiter is that the stator current and rotor current are individually limited. With the direct torque (in DTC) and rotor flux control (in FOC) regulators, neither the stator nor the rotor current is directly regulated.

[0082] Flux and torque command generators adaptively generate flux and torque commands in real-time, at the same or slower sampling rate as the main loop sampling rate.

[0083] One benefit of rotor flux regulation is that the rotor flux generally contains less harmonics than the stator flux and the airgap flux, resulting in improved control accuracy and reduced system jittering. In addition, the rotor flux slightly lags in phase the stator flux and the airgap flux, which may result in improved system stability and improved peak torque envelope limits.

[0084] One benefit of processing the main control loop in a reference frame aligned to the stator flux is that the stator flux angle computation can be more accurate and can converge faster, than computing a rotor flux angle.

[0085] With the above embodiments in mind, it should be understood that the embodiments might employ various computer-implemented operations involving data stored in computer systems. These operations are those requiring physical manipulation of physical quantities. Usually, though not necessarily, these quantities take the form of electrical or magnetic signals capable of being stored, transferred, combined, compared, and otherwise manipulated. Further, the manipulations performed are often referred to in terms, such as producing, identifying, determining, or comparing. Any of the operations described herein that form part of the embodiments are useful machine operations. The embodiments also relate to a device or an apparatus for performing these operations. The apparatus can be specially constructed for the required purpose, or the apparatus can be a general-purpose computer selectively activated or configured by a computer program stored in the computer. In particular, various general-purpose machines can be used with computer programs written in accordance with the teachings herein, or it may be more convenient to construct a more specialized apparatus to perform the required operations.

[0086] The embodiments can also be embodied as computer readable code on a computer readable medium. The computer readable medium is any data storage device that can store data, which can be thereafter read by a computer system. Examples of the computer readable medium include hard drives, network attached storage (NAS), read-only memory, random-access memory, CD-ROMs, CD-Rs, CD-RWs, magnetic tapes, and other optical and non-

optical data storage devices. The computer readable medium can also be distributed over a network coupled computer system so that the computer readable code is stored and executed in a distributed fashion. Embodiments described herein may be practiced with various computer system configurations including hand-held devices, tablets, microprocessor systems, microprocessor-based or programmable consumer electronics, minicomputers, mainframe computers and the like. The embodiments can also be practiced in distributed computing environments where tasks are performed by remote processing devices that are linked through a wire-based or wireless network.

**[0087]** Although the method operations were described in a specific order, it should be understood that other operations may be performed in between described operations, described operations may be adjusted so that they occur at slightly different times or the described operations may be distributed in a system which allows the occurrence of the processing operations at various intervals associated with the processing.

**[0088]** The foregoing description, for the purpose of explanation, has been described with reference to specific embodiments. However, the illustrative discussions above are not intended to be exhaustive or to limit the invention to the precise forms disclosed. Many modifications and variations are possible in view of the above teachings. The embodiments were chosen and described in order to best explain the principles of the embodiments and its practical applications, to thereby enable others skilled in the art to best utilize the embodiments and various modifications as may be suited to the particular use contemplated. Accordingly, the present embodiments are to be considered as illustrative and not restrictive, and the invention is not to be limited to the details given herein, but may be modified within the scope and equivalents of the appended claims.

## CLAIMS

What is claimed is:

1. A rotor flux estimator comprising:

5           an estimation module that generates a first rotor flux vector expressed in a phase voltage reference frame and a second rotor flux vector expressed in the phase voltage reference frame, from a stator voltage vector expressed in a phase voltage reference frame, a rotational speed of a rotor, and a stator current vector expressed in the phase voltage reference frame;

10           the estimation module including at least one processor; and

            the estimation module including a rotor flux current model and a rotor flux voltage model.

2. The rotor flux estimator of claim 1, further comprising:

15           a stator phase current reference frame to phase voltage reference frame vector rotation module that transforms a stator current of at least two phases to the stator current vector expressed in the phase voltage reference frame.

3. The rotor flux estimator of claim 1, further comprising:

20           a rotor flux magnitude calculator that calculates an estimated rotor flux magnitude from the first rotor flux vector.

4. The rotor flux estimator of claim 1, wherein applications of the rotor flux current model and the rotor flux voltage model are lookup-table-based.

25

5. The rotor flux estimator of claim 1, wherein applications of the rotor flux current model and the rotor flux voltage model are real-time-calculation-based.

6. The rotor flux estimator of claim 1, wherein:

a proportional-integral (PI) controller forms an error term from a difference between the first rotor flux vector and the second rotor flux vector; and

5 an output of the PI controller is applied as a correction factor to the rotor flux voltage model.

7. The rotor flux estimator of claim 1, wherein the rotor flux current model and the rotor flux voltage model are in cooperation with a regulator in production of the second rotor flux vector.

10

8. A rotor flux estimator, comprising:

a first module that generates, via application of a rotor flux current model, a first rotor flux vector expressed in a phase voltage reference frame from a stator current vector expressed in the phase voltage reference frame and a rotational speed of a rotor;

15 a second module that generates, via application of a rotor flux voltage model, a second rotor flux vector expressed in the phase voltage reference frame from a stator voltage vector expressed in the phase voltage reference frame, the stator current vector expressed in the phase voltage reference frame, and an estimation correction factor; and

20 an estimator regulator that generates the estimation correction factor from the first rotor flux vector expressed in the phase voltage reference frame and the second rotor flux vector expressed in the phase voltage reference frame, wherein at least one from a set consisting of: the first module, the second module, and the estimator regulator, includes a processor.

25 9. The rotor flux estimator of claim 8, wherein:

the estimator regulator includes a PI (proportional-integral) controller having as inputs the first rotor flux vector and the second rotor flux vector; and

the PI controller has as an output the estimation correction factor.

10. The rotor flux estimator of claim 8, wherein the estimator regulator includes:

a difference module that generates a difference between the first rotor flux vector and the second rotor flux vector;

5 a proportional module that generates a first term proportional to the difference between the first rotor flux vector and the second rotor flux vector;

an integral module that generates a second term proportional to an integral of the difference between the first rotor flux vector and the second rotor flux vector; and

a summation module that generates the estimation correction factor as a summation of the first term and the second term.

10

11. The rotor flux estimator of claim 8, further comprising:

a rotor flux magnitude calculator that receives the first rotor flux vector and generates an estimated rotor flux magnitude based upon a lookup table or a real-time calculation.

15 12. The rotor flux estimator of claim 8, further comprising:

a stator flux calculator that generates a stator flux vector expressed in the phase voltage reference frame from the second rotor flux vector expressed in the phase voltage reference frame and the stator current vector expressed in the phase voltage reference frame; and

20 a rotor current calculator that generates a rotor current vector expressed in the phase voltage reference frame from the first rotor flux vector expressed in the phase voltage reference frame and the stator flux vector expressed in the phase voltage reference frame.

13. The rotor flux estimator of claim 8, further comprising:

25 a stator flux calculator that generates a stator flux vector expressed in the phase voltage reference frame from the second rotor flux vector expressed in the phase voltage reference frame and the stator current vector expressed in the phase voltage reference frame, the stator flux calculator including a model of inductances for windings of an induction motor.

14. The rotor flux estimator of claim 8, further comprising:

a stator flux calculator that generates a stator flux vector expressed in the phase voltage reference frame from the second rotor flux vector expressed in the phase voltage reference frame and the stator current vector expressed in the phase voltage reference frame;  
5 and

a torque calculator that generates an estimated torque from the stator flux vector expressed in the phase voltage reference frame and the stator current vector expressed in the phase voltage reference frame.

10

15. The rotor flux estimator of claim 8, further comprising:

a stator flux calculator that generates a stator flux vector expressed in the phase voltage reference frame from the second rotor flux vector expressed in the phase voltage reference frame and the stator current vector expressed in the phase voltage reference frame;  
15 and

a stator flux angle calculator that generates an estimated stator flux angle from the stator flux vector expressed in the phase voltage reference frame.

16. A method of estimating rotor flux, comprising:

20 producing a first rotor flux vector, expressed in a phase voltage reference frame, from a stator current vector expressed in the phase voltage reference frame and a rotational speed of a rotor, via application of a rotor flux current model;

producing a second rotor flux vector, expressed in the phase voltage reference frame, from the stator current vector expressed in the phase voltage reference frame, a stator voltage vector expressed in the phase voltage reference frame, and an estimation correction factor,  
25 via application of a rotor flux voltage model; and

producing the estimation correction factor from a difference between the first rotor flux vector and the second rotor flux vector, wherein at least one method operation is executed through a processor.

30

17. The method of claim 16, wherein producing the estimation correction factor includes:

producing an integration of the difference between the first rotor flux vector and the second rotor flux vector; and

5 summing a first term proportional to the difference between the first rotor flux vector and the second rotor flux vector and a second term proportional to the integration of the difference between the first rotor flux vector and the second rotor flux vector.

18. The method of claim 16, further comprising:

producing a rotor flux magnitude from the first rotor flux vector; and

10 producing a stator flux angle from the stator current vector expressed in the phase voltage reference frame and the second rotor flux vector.

19. The method of claim 16, further comprising:

15 producing a torque from the stator current vector expressed in the phase voltage reference frame and the second rotor flux vector.

20. The method of claim 16, further comprising:

producing a rotor current vector from the stator current vector expressed in the phase voltage reference frame, the first rotor flux vector, and the second rotor flux vector.

20

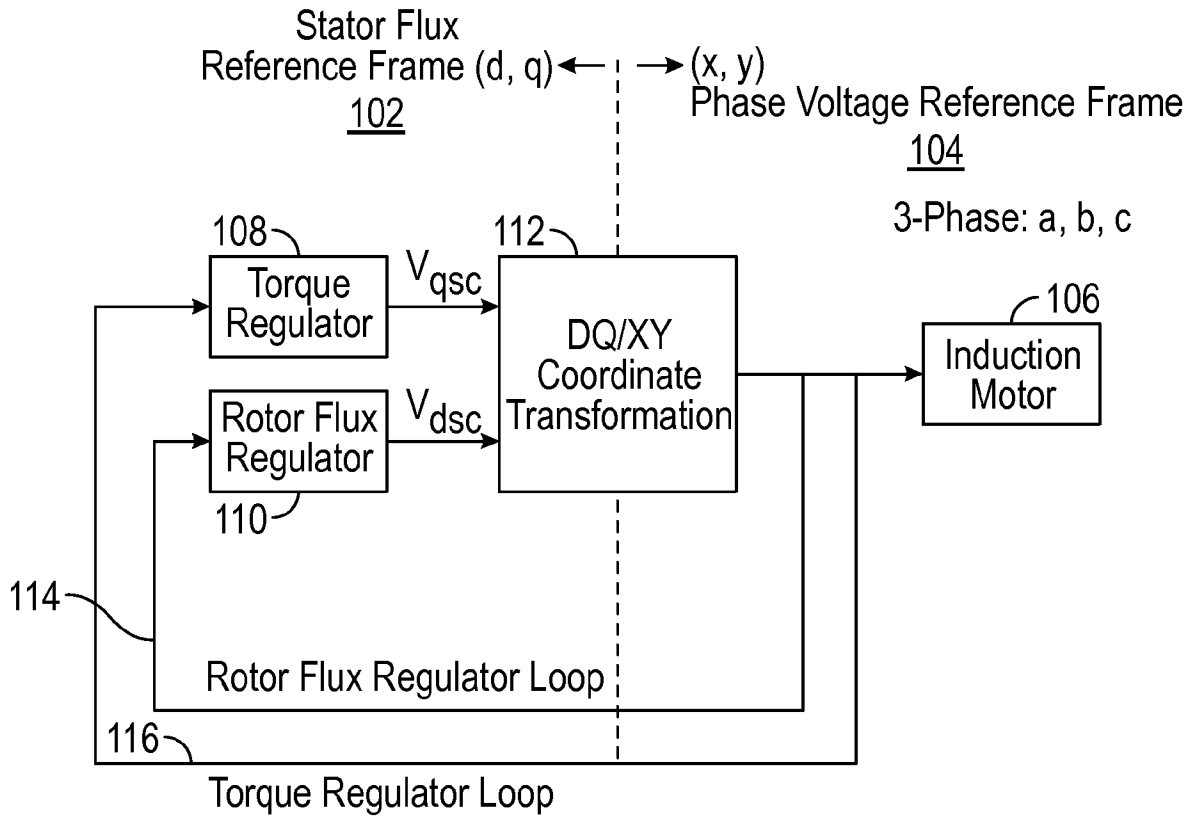

FIG. 1

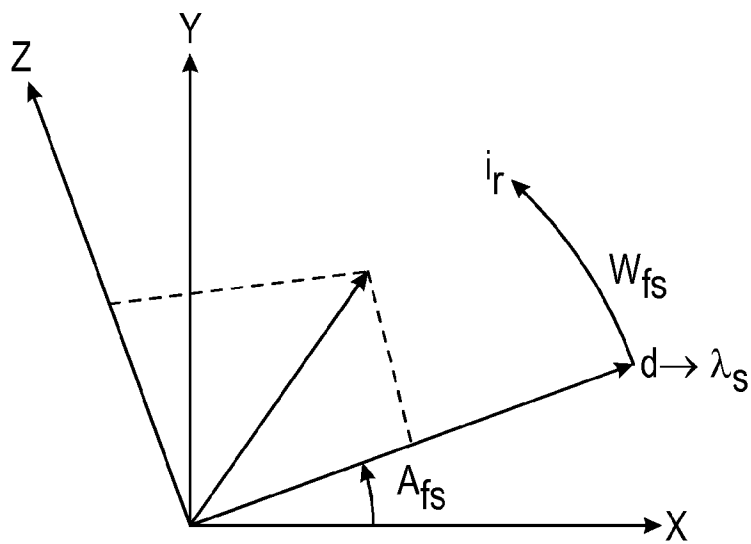

FIG. 2

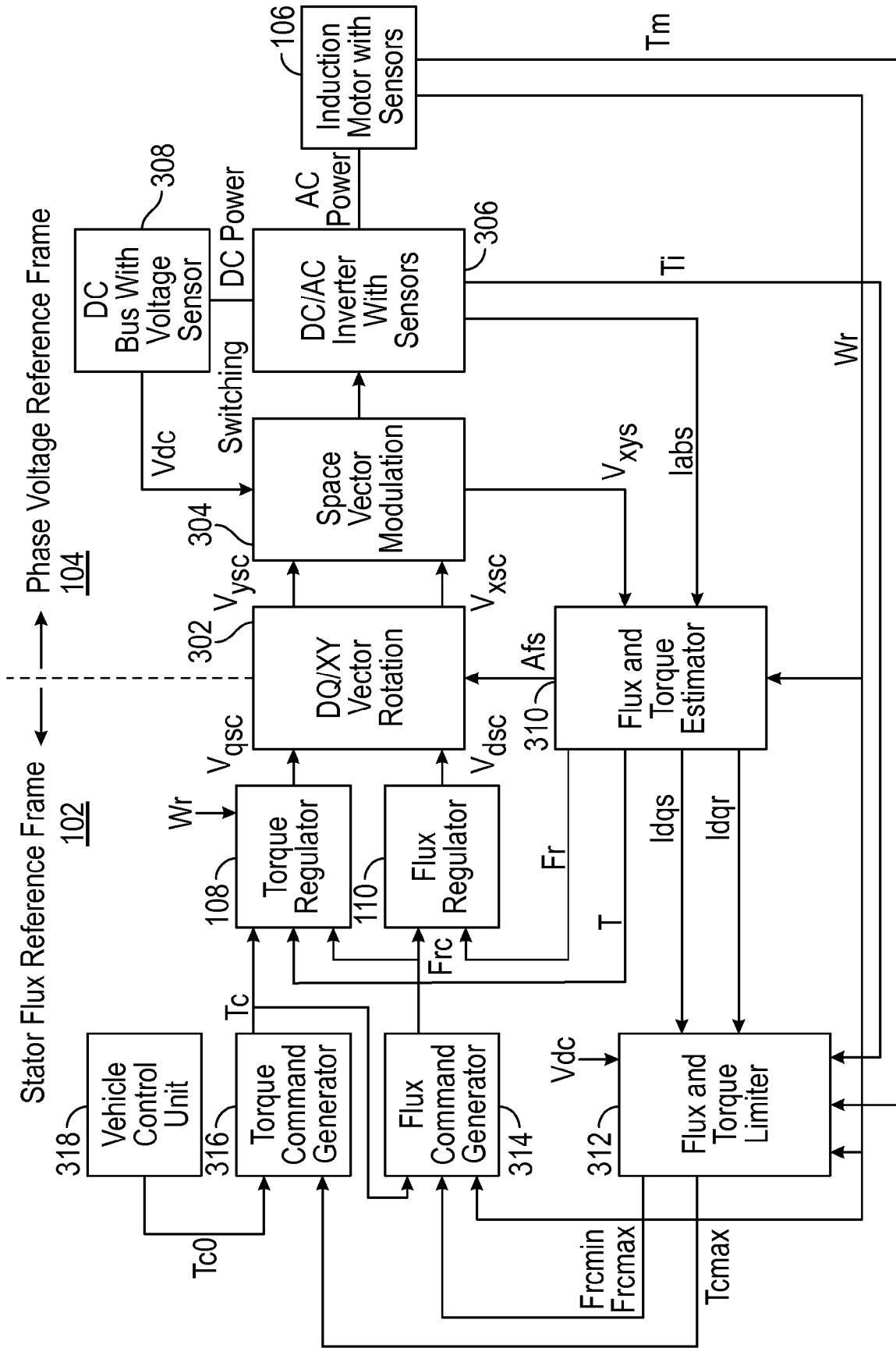

FIG. 3



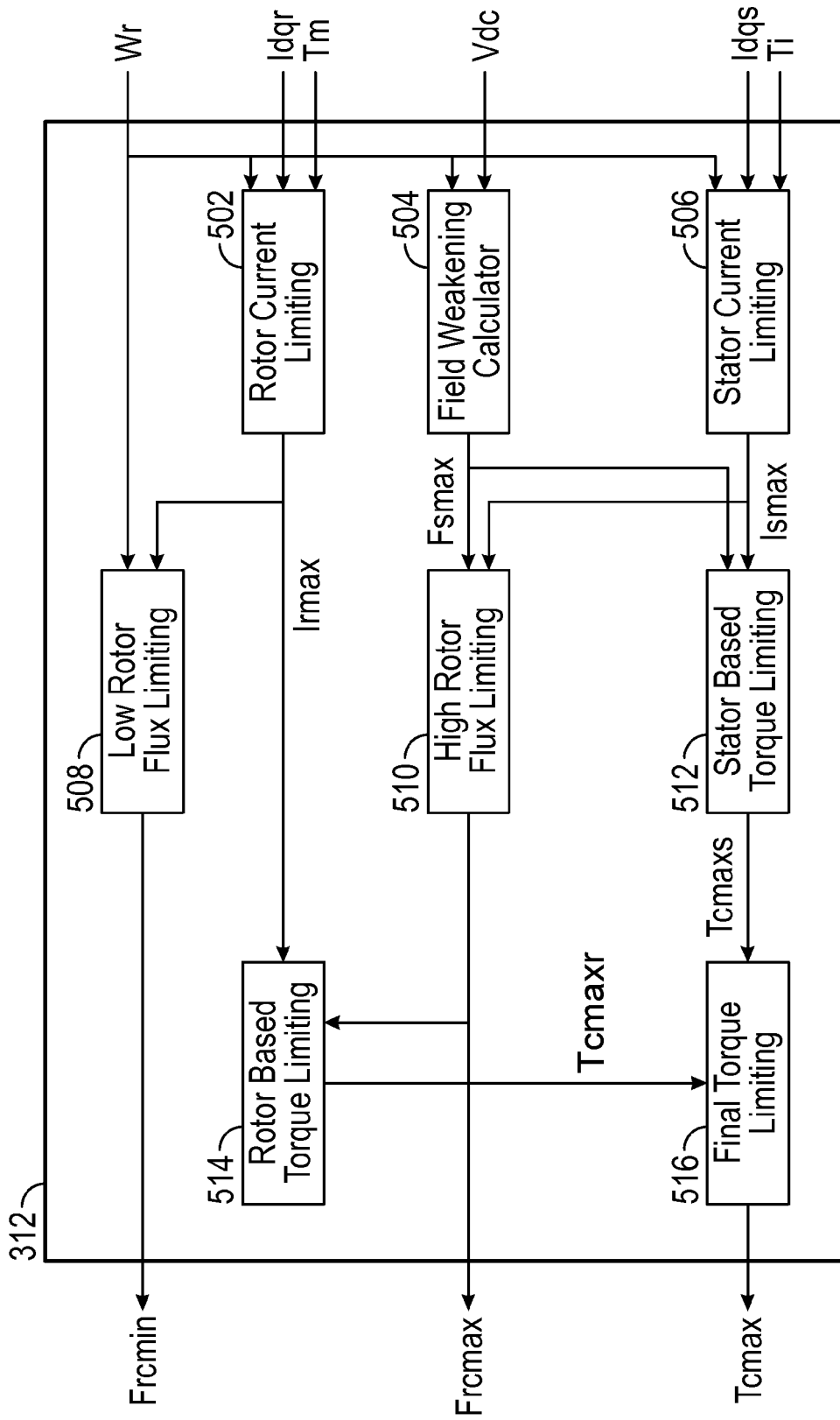

FIG. 5

5/6

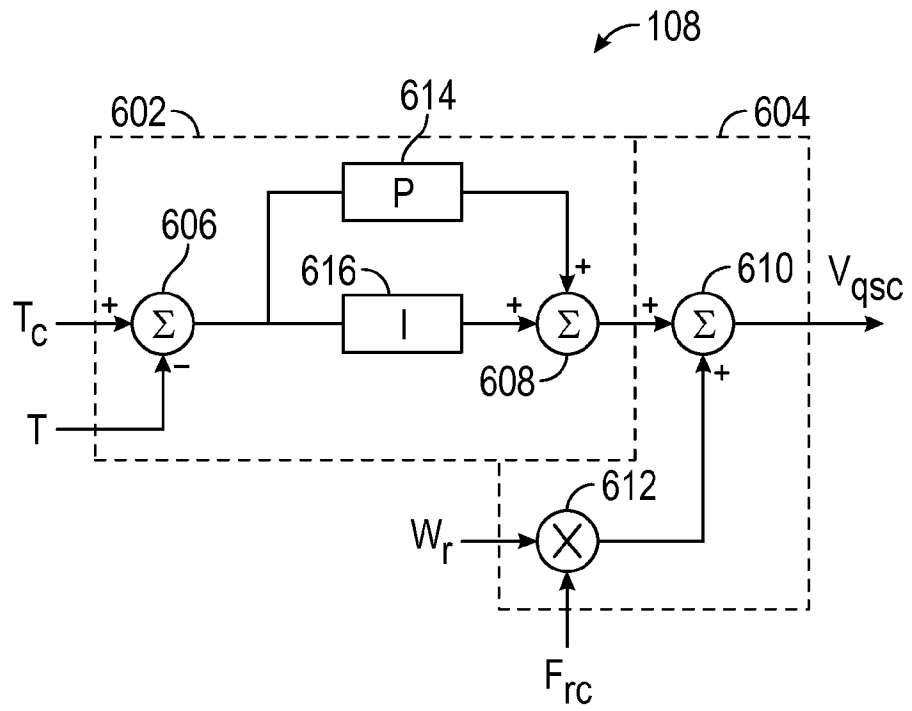

FIG. 6

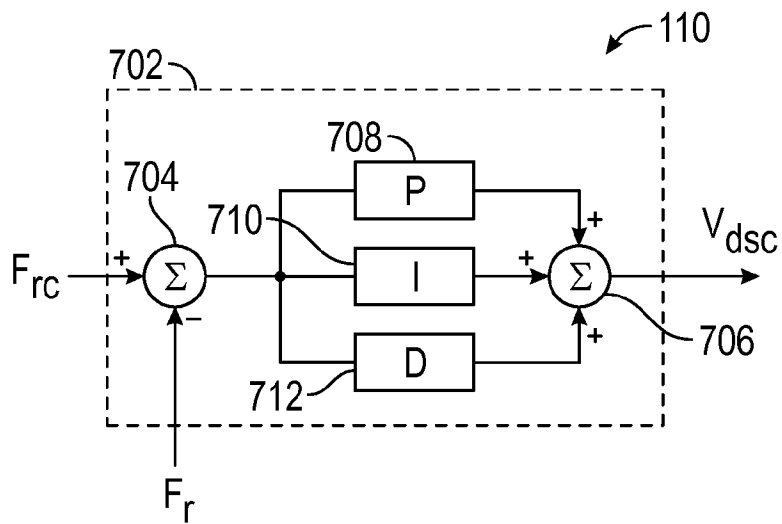

FIG. 7

6/6

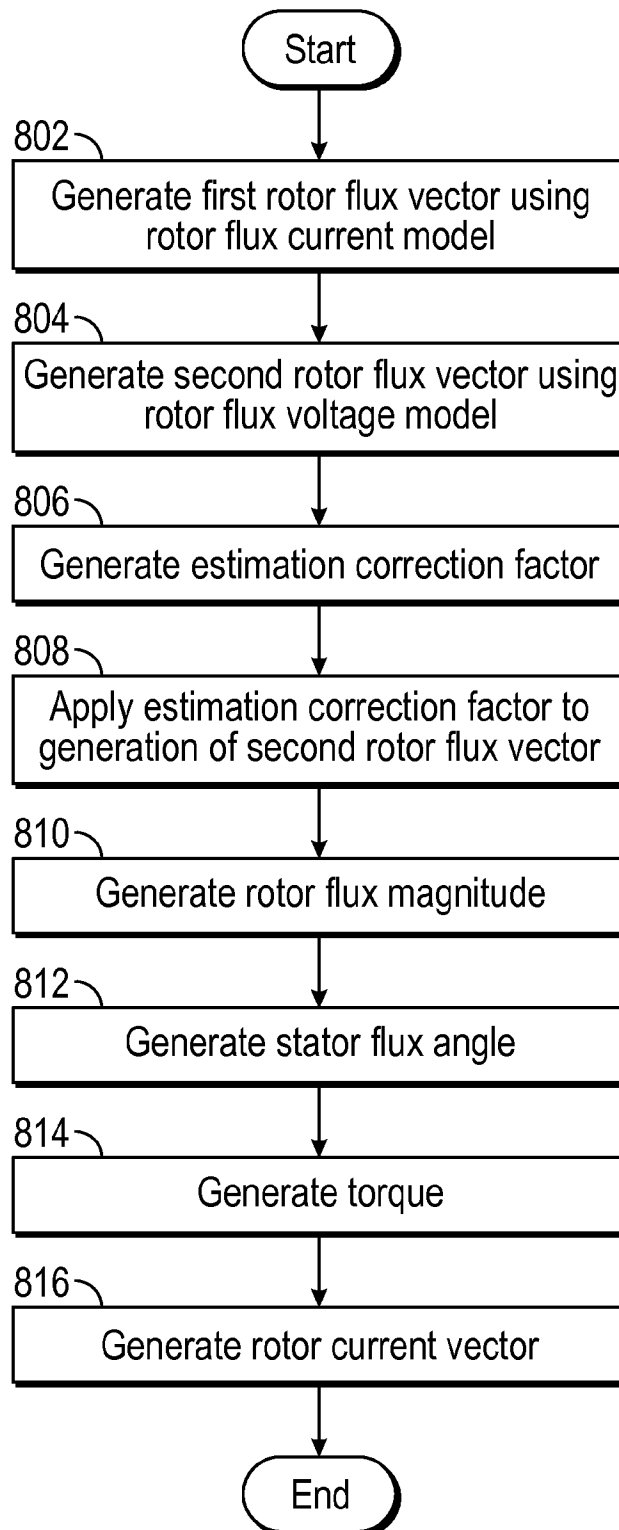

FIG. 8

## INTERNATIONAL SEARCH REPORT

International application No.

PCT/US 14/47735

| <b>A. CLASSIFICATION OF SUBJECT MATTER</b><br>IPC(8) - H02P 21/14 (2014.01)<br>CPC - H02P 21/141<br>According to International Patent Classification (IPC) or to both national classification and IPC   |  |  |
|---|--|--|
| <b>B. FIELDS SEARCHED</b><br>Minimum documentation searched (classification system followed by classification symbols)<br>IPC(8) - H02P 21/14 (2014.01)<br>CPC - H02P 21/141<br>Documentation searched other than minimum documentation to the extent that such documents are included in the fields searched<br>IPC(8)- H02P21/06, H02P21/14* (2014.01) CPC- H02P21/06, H02P21/08*, H02P21/10, H02P21/141, H02P21/145, H02P2207/01<br>USPC-318/727,818,821 (keyword delimited)<br>Electronic data base consulted during the international search (name of data base and, where practicable, search terms used)<br>Patbase, Proquest Dialog, Google Patents<br>Search terms used: rotor flux estimator, phase voltage reference frame, current model, voltage model, rotor flux vector, stator flux vector, stator flux angle, stationary frame |  |  |
| <b>C. DOCUMENTS CONSIDERED TO BE RELEVANT</b>   |  |  |
| Category*   | Citation of document, with indication, where appropriate, of the relevant passages   | Relevant to claim No.  |
| X<br>-<br>Y<br>-<br>A   | US 6,388,419 B1 (Chen et al.) 14 May 2002 (14.05.2002), Fig 2, 8, 10; col 3, ln 38-41; col 9, ln 1-15; col 10, ln 65-67; col 11, ln 2-9; col 4, ln 26-35 | 1, 2, 7, 8, 16, 19<br>-----<br>3-6, 9-11, 17<br>-----<br>12-15, 18, 20   |
| Y<br>-<br>A   | US 2012/0161685 A1 (Geyer et al.) 28 June 2012 (28.06.2012), para [0064],[0095]  | 3-5, 11<br>-----<br>18, 20   |
| Y   | US 6,137,258 A (Jansen) 24 October 2000 (24.10.2000), Fig 2; col 7, ln 28-40   | 6, 9, 10, 17   |
| A   | US 7,745,949 B2 (Yang et al.) 29 June 2010 (29.06.2010), abstract  | 12-15  |
| <input type="checkbox"/> Further documents are listed in the continuation of Box C. <input type="checkbox"/>  |  |  |
| * Special categories of cited documents:<br>"A" document defining the general state of the art which is not considered to be of particular relevance<br>"E" earlier application or patent but published on or after the international filing date<br>"L" document which may throw doubts on priority claim(s) or which is cited to establish the publication date of another citation or other special reason (as specified)<br>"O" document referring to an oral disclosure, use, exhibition or other means<br>"P" document published prior to the international filing date but later than the priority date claimed  |  | "T" later document published after the international filing date or priority date and not in conflict with the application but cited to understand the principle or theory underlying the invention<br>"X" document of particular relevance; the claimed invention cannot be considered novel or cannot be considered to involve an inventive step when the document is taken alone<br>"Y" document of particular relevance; the claimed invention cannot be considered to involve an inventive step when the document is combined with one or more other such documents, such combination being obvious to a person skilled in the art<br>"&" document member of the same patent family |
| Date of the actual completion of the international search<br>17 October 2014 (17.10.2014)   |  | Date of mailing of the international search report<br><b>21 NOV 2014</b>   |
| Name and mailing address of the ISA/US<br>Mail Stop PCT, Attn: ISA/US, Commissioner for Patents<br>P.O. Box 1450, Alexandria, Virginia 22313-1450<br>Facsimile No. 571-273-3201   |  | Authorized officer:<br>Lee W. Young<br>PCT Helpdesk: 571-272-4300<br>PCT OSP: 571-272-7774   |