

No. 892,902.

PATENTED JULY 7, 1908.

J. SCHUTZ.

PATTERN MECHANISM FOR STRAIGHT KNITTING MACHINES.

APPLICATION FILED JULY 6, 1907.

5 SHEETS—SHEET 1.

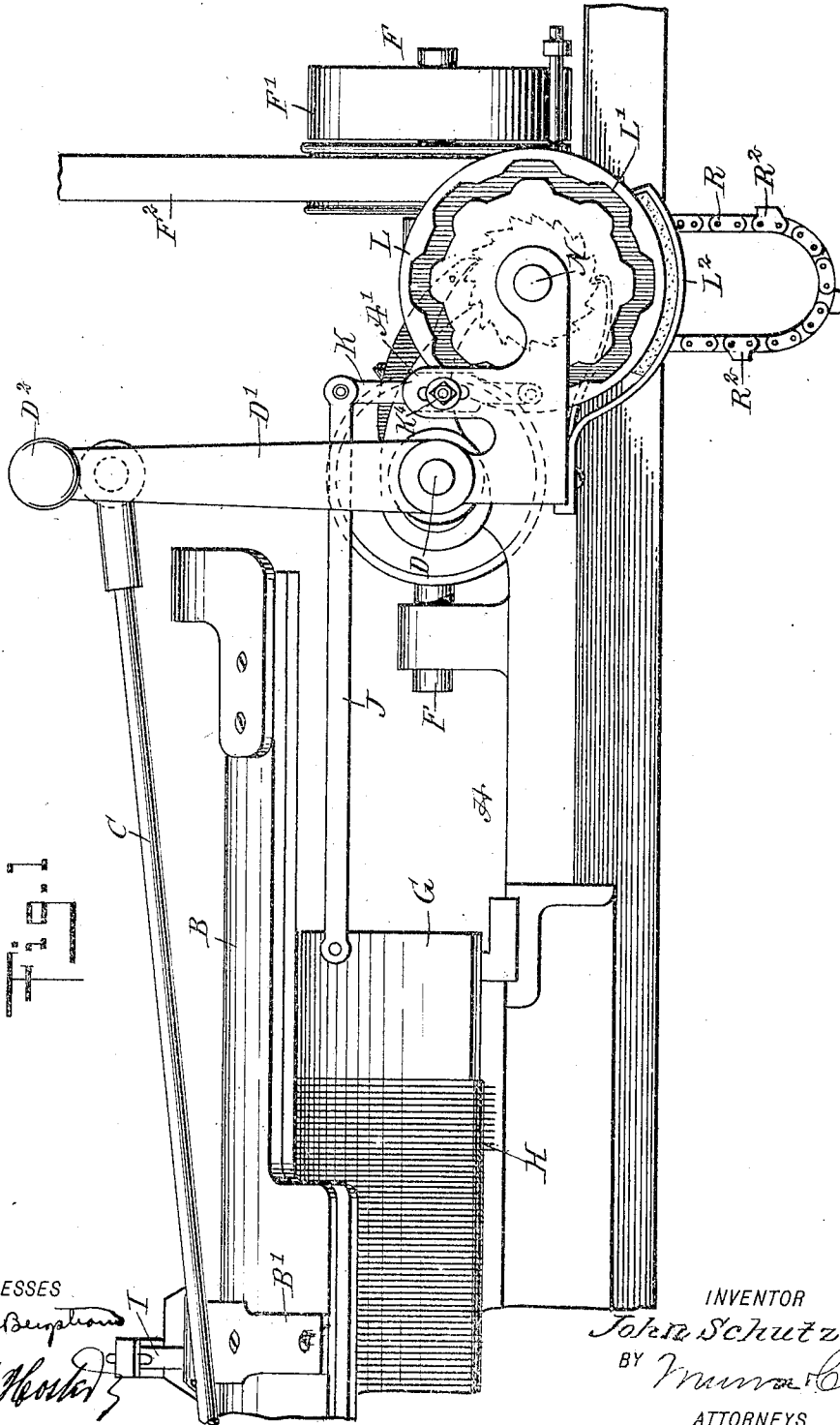

WITNESSES
John Beuphan
Reed Hoster

INVENTOR
John Schutz
BY *Munn & Co.*
ATTORNEYS

No. 892,902.

PATENTED JULY 7, 1908.

J. SCHUTZ.

PATTERN MECHANISM FOR STRAIGHT KNITTING MACHINES.

APPLICATION FILED JULY 5, 1907.

5 SHEETS—SHEET 2.

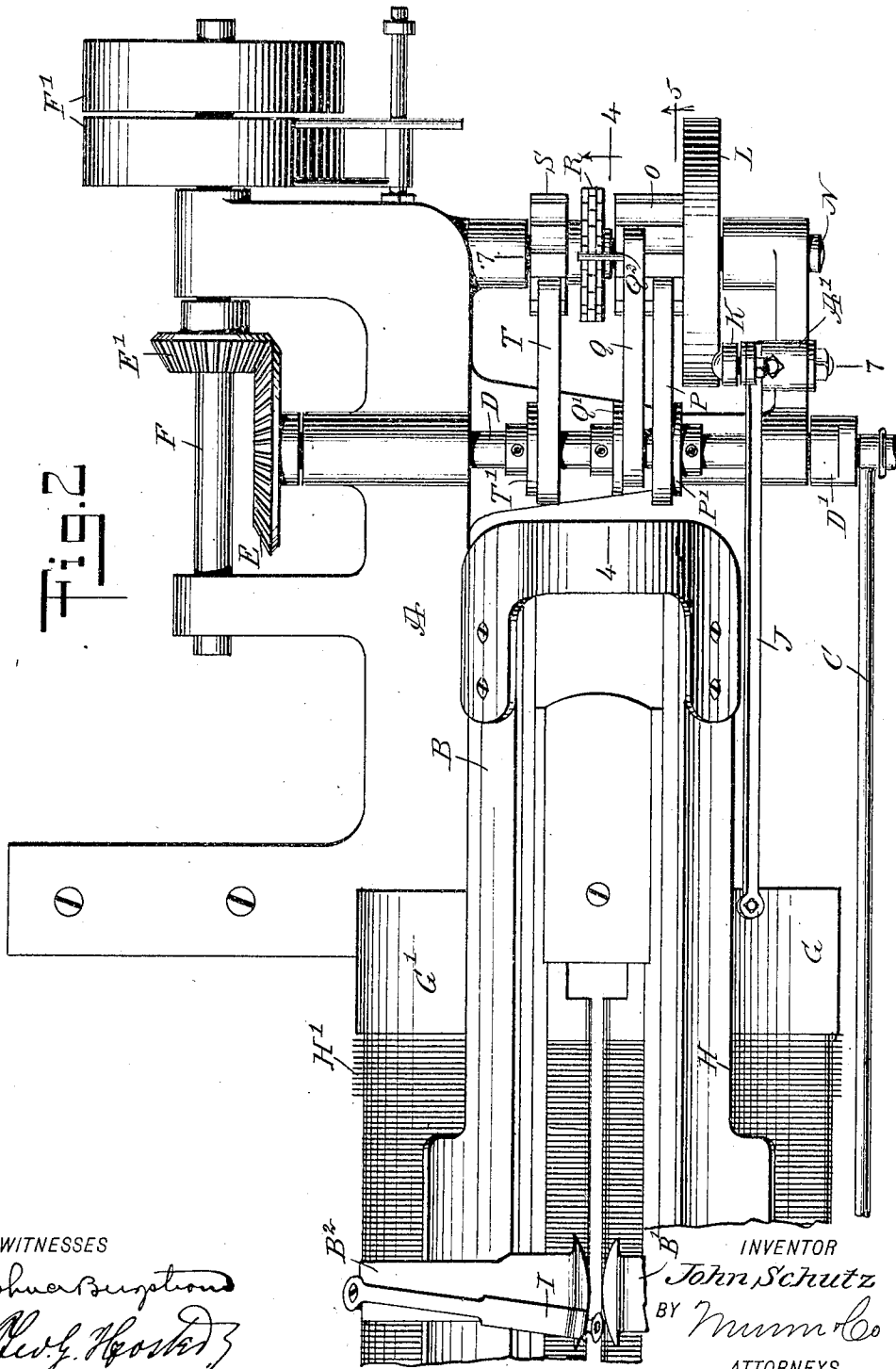

Fig. 2

WITNESSES
John Supton
Rev. H. Hooper

INVENTOR
John Schutz
BY *Munn Co*
ATTORNEYS

No. 892,902.

PATENTED JULY 7, 1908.

J. SCHUTZ.

PATTERN MECHANISM FOR STRAIGHT KNITTING MACHINES.

APPLICATION FILED JULY 5, 1907.

5 SHEETS—SHEET 3.

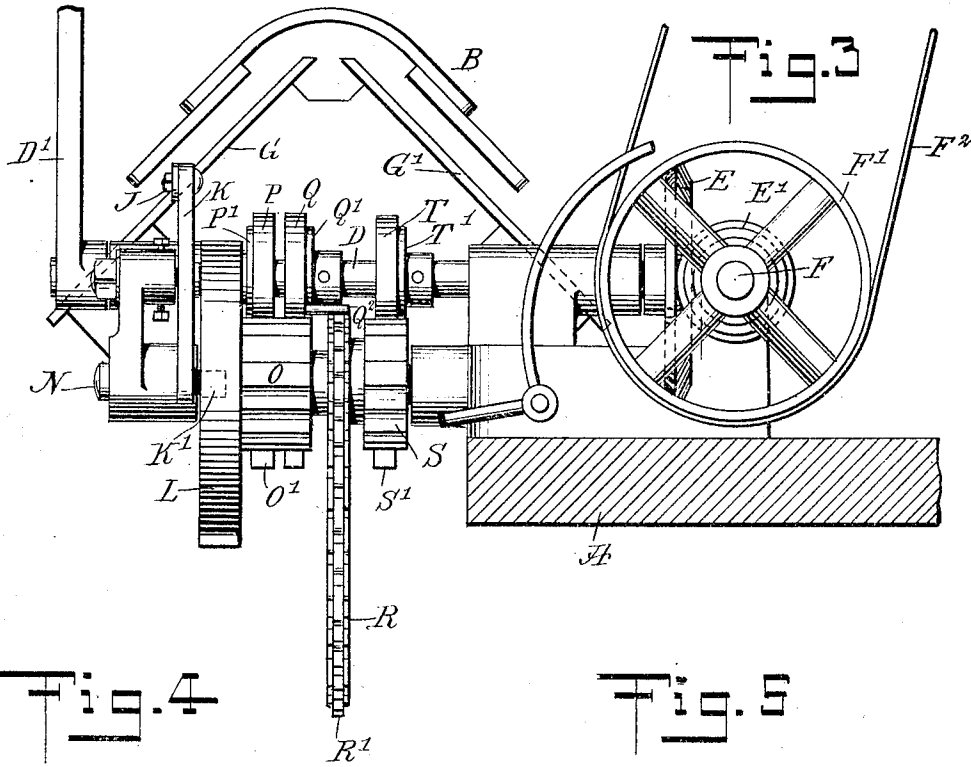
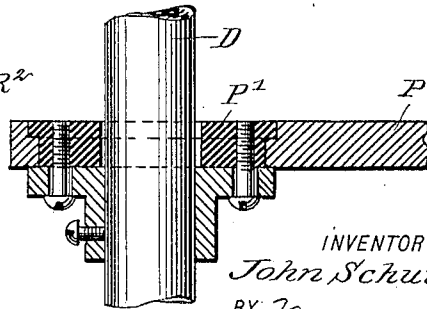
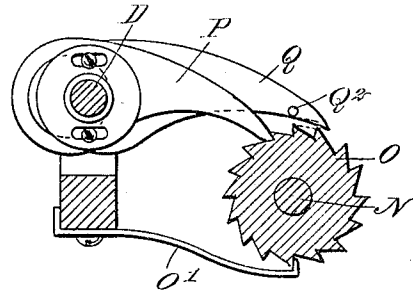
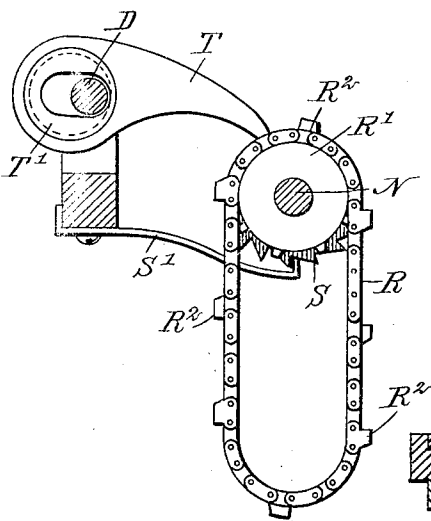

Fig. 4

Fig. 5



WITNESSES
John Bergeron
Wm. G. Koster

Fig. 6

INVENTOR
John Schutz
BY *Mum Co.*
ATTORNEYS

No. 892,902.

PATENTED JULY 7, 1908.

J. SCHUTZ.

PATTERN MECHANISM FOR STRAIGHT KNITTING MACHINES.

APPLICATION FILED JULY 5, 1907.

5 SHEETS—SHEET 4.

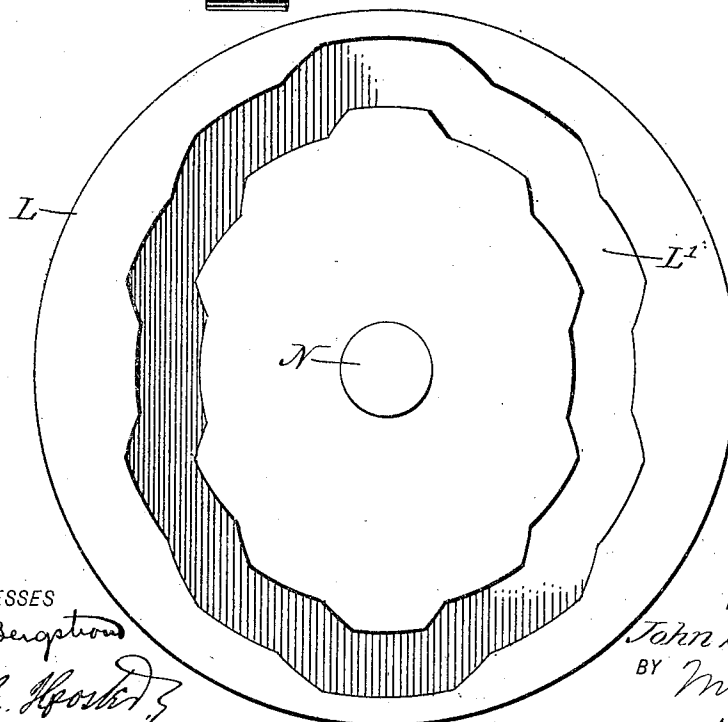
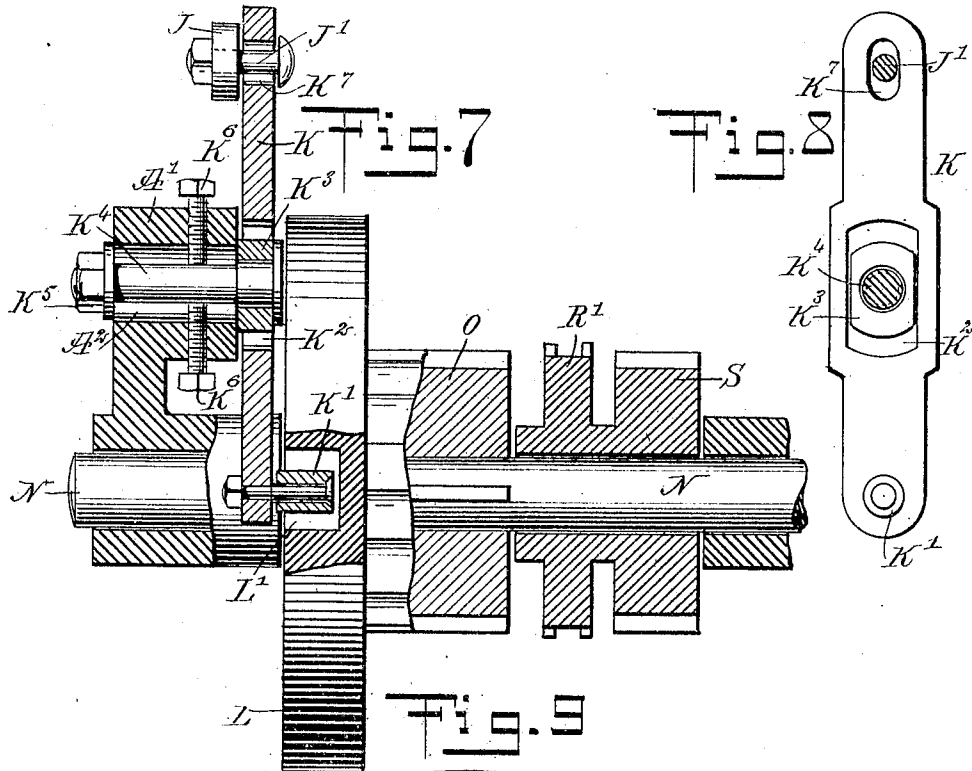

WITNESSES
John A. Bergstrom
Rev. J. H. Foster

INVENTOR
John Schutz
BY *Mumford & Co.*
ATTORNEYS

J. SCHUTZ.

PATTERN MECHANISM FOR STRAIGHT KNITTING MACHINES.

APPLICATION FILED JULY 5, 1907.

5 SHEETS—SHEET 5.

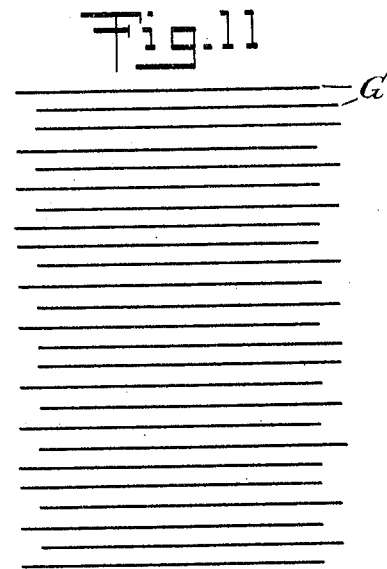
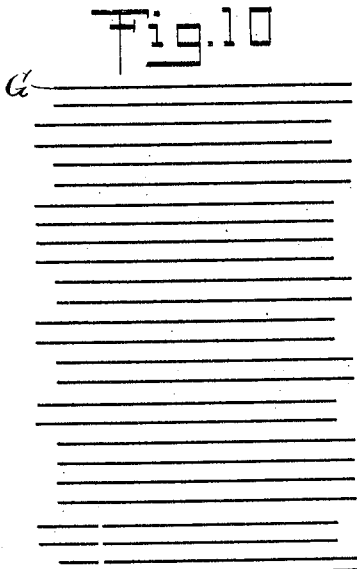
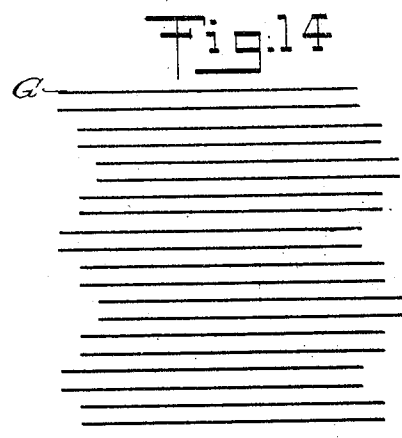
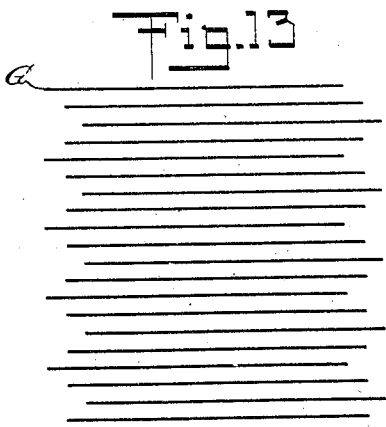
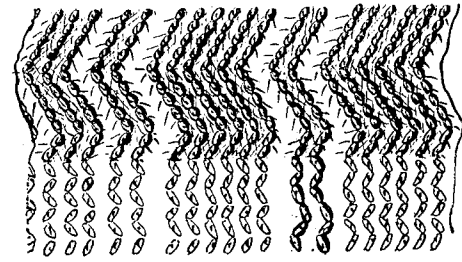

Fig. 12



WITNESSES
John S. ...
Rev. G. ...

INVENTOR
John Schutz
 BY *Mum & Co.*
 ATTORNEYS

UNITED STATES PATENT OFFICE.

JOHN SCHUTZ, OF NEW YORK, N. Y., ASSIGNOR OF ONE-THIRD TO THEODORE HAEBLER, OF NEW YORK, N. Y.

PATTERN MECHANISM FOR STRAIGHT-KNITTING MACHINES

No. 892,902.

Specification of Letters Patent.

Patented July 7, 1908.

Application filed July 5, 1907. Serial No. 382,377.

To all whom it may concern:

Be it known that I, JOHN SCHUTZ, a citizen of the United States, and a resident of the city of New York, borough of Brooklyn, in the county of Kings and State of New York, have invented a new and Improved Pattern Mechanism for Straight-Knitting Machines, of which the following is a full, clear, and exact description.

The invention relates to knitting machines having two straight rows of needles arranged on opposite sides; and its object is to provide a new and improved knitting machine arranged to automatically vary the relation of successive rows of stitches according to a predetermined design, for producing a fabric of a highly ornamental character.

The invention consists of novel features and parts and combinations of the same, which will be more fully described herein-after and then pointed out in the claims.

A practical embodiment of the invention is represented in the accompanying drawings forming a part of this specification, in which similar characters of reference indicate corresponding parts in all the views.

Figure 1 is a side elevation of the improvement; Fig. 2 is a plan view of the same; Fig. 3 is an end elevation of the same; Fig. 4 is a sectional side elevation of the improvement on the line 4—4 of Fig. 2; Fig. 5 is a similar view of the same on the line 5—5 of Fig. 2; Fig. 6 is an enlarged sectional plan view of one of the pawls, and the eccentric and shaft for imparting motion to the pawl; Fig. 7 is an enlarged transverse section of the improvement on the line 7—7 of Fig. 2; Fig. 8 is a face view of the cam lever and the means for adjusting the throw thereof, parts being shown in section; Fig. 9 is an enlarged face view of one of the interchangeable cams for knitting fabrics differently ornamented; Fig. 10 is a diagrammatic view showing the different positions of the movable needle plate for succeeding rows of stitches; Fig. 11 is a similar view of the same and showing different positions of the needle plate; Fig. 12 is an enlarged face view of a fabric knitted by the use of the change arrangement shown in Figs. 1 to 8; Fig. 13 is a diagrammatic view of the different positions of a movable needle plate for knitting fabrics having a different design, and Fig. 14 is a like view of the same showing a movable needle plate in

various positions for knitting a fabric of another design.

The knitting machine is mounted on a suitably constructed frame A on which reciprocates the carriage B connected by a pitman C with the crank arm D' of a crank shaft D extending transversely and journaled on the main frame A. The crank shaft B is connected by the bevel gear wheels E and E' with the main driving shaft F, extending longitudinally and journaled in suitable bearings on the main frame A. On the main driving shaft F are arranged fast and loose pulleys F' connected by a belt F² with other machinery, for imparting a continuous rotary motion to the shafts F and D, so that the crank arm D' and the pitman C impart a reciprocating motion to the carriage B. The crank arm D' is provided with a handle D² for conveniently turning the crank arm D' by hand, to permit the operator to shift the carriage B when starting the machine or in case of a break or the like.

The needle plates G, G' are inclined toward each other and are provided with suitable guideways for the two rows of needles H and H' to which the yarn or thread is passed from the oscillating yarn carrier I extending between the usual guide arms B', B² secured to the carriage B. The needles H, H' are actuated by the usual needle actuating devices held on the carriage B and moving with the same, so that further description of the same is not deemed necessary. The needle plate G' is fixed on one side of the main frame A, while the needle plate G is mounted to slide lengthwise on the other side of the main frame, and this slidable needle plate G receives an intermittent reciprocating motion to vary the rows of stitches, one relative to the other according to a predetermined design for making shogged or crossed stitch work. For the purpose mentioned the needle plate G is connected by a pitman J with the upper end of a lever K, carrying at its lower end a friction roller K' engaging a cam groove L' formed on a cam L, which is one of a series of interchangeable cams (see Figs. 1 and 9), either one of which may be removably secured on a cam shaft N extending transversely and journaled in suitable bearings on the main frame A.

In order to permit of using the same cam

L on one machine when using the interchangeable plates G, G' having more or less needles to the inch, it is necessary to adjust the throw of the lever K, and for this purpose the said lever K is provided at or near the middle with a vertical elongated slot K² into which fits a block K³ mounted to turn on a bolt K⁴ adjustably secured in a bearing A' of the main frame A (see Figs. 7 and 8). The bearing A' is provided with a vertical elongated slot A² for the passage of the bolt stud K⁴, to allow of moving the bolt stud K⁴ up or down, to vary the throw of the lever K according to the number of needles per inch in the needle plates G and G' used at a time in the machine. The bolt K⁴ after being adjusted up or down is locked in place on the bearing A' by its nut K⁵ and by adjusting screws K⁶ screwing in the top and bottom of the bearing A'. A pivot pin J' for connecting the pitman J with the lever K is adjustably secured in an elongated slot K⁷ formed in the upper end of the lever K, as plainly indicated in Figs. 7 and 8.

On the cam wheel L is secured or formed a ratchet wheel O of a width sufficient to accommodate two pawls P and Q, used for imparting a turning motion to the ratchet wheel O and consequently to the cam wheel L, so that the latter imparts a swinging motion to the lever K, which by the pitman J shifts the needle plate G in a longitudinal direction, and at the time the carriage B is at the end of either its forward or backward stroke. The pawls P and Q are actuated by eccentrics P' and Q' secured to the crank shaft D, and arranged in diametrical positions, one relative to the other, so as to actuate the pawls P and Q in opposite directions, that is, when the pawl P is on its active stroke and turns the ratchet wheel O, then the pawl Q is on the return or inactive stroke and glides over the ratchet wheel O and vice versa. Accidental return movement of the ratchet wheel O is prevented by a spring dog O' (see Fig. 5).

In order to vary the shifting of the needle plate G by the pawls P and Q, the pawl Q is periodically thrown out of engagement with the ratchet wheel O, so that only the pawl P remains active, and the needle plate G is shifted only when the carriage B is at the end of its stroke. For the purpose mentioned the following device is provided: The free end of the pawl Q is provided with a transversely extending pin Q² reaching over onto the top of a sprocket chain R hung on a sprocket wheel R', mounted to rotate loosely on the shaft N, and on the said sprocket wheel R' is secured or formed a ratchet wheel S engaged by a pawl T mounted on an eccentric T' attached to the crank shaft D, so that when the machine is running the crank shaft D and the eccentric T' impart motion to the pawl T, to intermittently turn the ratchet

wheel S and consequently the sprocket wheel R'. The movement given to the sprocket wheel R' causes an intermittent traveling of the sprocket chain R, which is provided at some of its links with projections R² adapted to engage and raise the pin Q² to swing the pawl Q out of engagement with the ratchet wheel O. Thus as long as the pawl Q is in its raised position it is rendered wholly inactive, relative to the ratchet wheel O, and consequently the latter is only intermittently turned by the pawl P, to shift the needle plate G only at the end of the forward stroke of the carriage B. As the sprocket chain R receives an intermittent traveling motion by the pawl P, it is evident that the projection R² in engagement with the pin Q² at the time, finally leaves the latter, so that the pawl Q swings downward back into engagement with the ratchet wheel O, to again assume its function, that is, to turn the ratchet wheel O and the cam L for shifting the needle plate G at the time the carriage B is at the rear end of its stroke. Now by varying the links in the sprocket chain R carrying the projections R², that is, by spacing the projections R² nearer to or farther apart, it is evident that the pawl Q is rendered inactive at different periods, to vary the design of the fabric. If desired the pawl Q may be completely thrown out of engagement with the ratchet wheel O by the operator for a certain kind of work, so that only the pawl P remains active. Return movement of the ratchet wheel S is prevented by a spring dog S' (see Fig. 4.) By using different sprocket chains R having projections R² nearer, toward or farther from each other, a great variety of differently ornamented fabrics can be knitted on the machine, and in a like manner the designs can be varied by using cams L having their cam grooves L' of various forms, as will be readily understood by comparison of Figs. 1 to 9.

It is understood that variations in the sprocket chains R and cams L produce a different shifting of the needle plate at different periods and different distances, and hence a corresponding variation in the successive rows of stitches in the fabric is produced.

Thus the needle plate G can be shifted alternately forward and backward at the end of each forward and backward stroke of the carriage B, or at alternate strokes of the carriage or at any number of strokes and in any desired sequence, as will be readily understood by reference to Figs. 10, 11, 13 and 14, which show some of the different positions into which the needle plate G can be shifted by the use of different cams L and chains R. The throw given to the needle plate G at a time corresponds to the distance between adjacent needles, but the needle plate can be intermittently shifted in various ways, for instance, stepwise, first in one

direction and then in the reverse direction (see Figs. 13 and 14), the needle plate remaining stationary in any one of its shifted positions for any desired number of rows of stitches.

Having thus described my invention, I claim as new and desire to secure by Letters Patent:

1. A knitting machine provided with needle plates, of which one is movable in the direction of its length, needles mounted on the needle plates, a reciprocating carriage for actuating the needles, and a shifting mechanism for the said movable needle plate to variably shift the latter whenever the carriage reaches the end of its stroke, and having a cam, means for intermittently rotating the cam, and means for retarding the speed of the cam at predetermined intervals.

2. A knitting machine provided with needle plates, of which one is movable in the direction of its length, needles mounted on the needle plates, a reciprocating carriage for actuating the needles, and a shifting mechanism for the said movable needle plate comprising a lever mounted with the said movable needle plate, a cam for imparting motion to the said lever, actuating means for turning the said cam, and means for varying the action of the said actuating means.

3. A knitting machine provided with needle plates, of which one is movable in the direction of its length, needles mounted on the needle plates, a reciprocating carriage for actuating the needles, and a shifting mechanism for the said movable needle plate, comprising a lever mounted with the said movable needle plate, a cam for imparting motion to the said lever, actuating means for turning the said cam, and a chain mechanism for controlling the said actuating means.

4. A knitting machine provided with needle plates, of which one is movable in the direction of its length, needles mounted on the needle plates, a reciprocating carriage for actuating the needles, and a shifting mechanism for the said movable needle plate, comprising a lever connected with the said movable needle plate, a cam for actuating the said lever, a double pawl and ratchet mechanism for turning the said cam, and a controlling device for throwing one of the pawls of the said mechanism in and out of gear.

5. A knitting machine provided with needle plates, of which one is movable in the direction of its length, needles mounted on the needle plates, a reciprocating carriage for actuating the needles, and a shifting mechanism for the said movable needle plate com-

prising a lever connected with the said movable needle plate, a cam for actuating the said lever, a double pawl and ratchet mechanism for turning the said cam, and a controlling device having an intermittently rotating sprocket wheel, and a chain passing over the said sprocket wheel, the chain having projections for throwing one of the pawls of the said mechanism in and out of gear.

6. A knitting machine provided with a shifting device for a needle plate, comprising a lever connected with the said needle plate, a cam engaging the said lever, a ratchet wheel rotating with the said cam, a pair of pawls for turning the said ratchet wheel, and means for throwing one of the said pawls periodically in and out of gear.

7. A knitting machine provided with a shifting device for a needle plate comprising a lever connected with the said needle plate, a cam engaging the said lever, a ratchet wheel rotating with the said cam, a pair of pawls for turning the said ratchet wheel, one of the pawls having a pin, means for actuating the pawls, a sprocket wheel, means for intermittently turning the said sprocket wheel, and a sprocket chain on the said sprocket wheel and having spaced projections for engagement with the said pin to throw the said pin pawl in and out of gear with the said ratchet wheel.

8. A knitting machine provided with needle plates, of which one is movable in the direction of its length, needles mounted on the needle plates, a reciprocating carriage for actuating the needles, and a shifting mechanism for the said movable needle plate, comprising a lever connected with the said movable needle plate, a cam for imparting motion to the said lever, actuating means for turning the said cam, controlling means for controlling the said actuating means, and means for adjusting the fulcrum of the said lever to vary the throw of the latter.

9. A knitting machine provided with a movable needle plate carrying a row of needles, a lever connected with the said needle plate, means for actuating the said lever, and means for adjusting the fulcrum of the said lever with respect to the lever to regulate the throw thereof.

In testimony whereof I have signed my name to this specification in the presence of two subscribing witnesses.

JOHN SCHUTZ.

Witnesses.

THEO. G. HOSTER,
JOHN P. DAVIS.