

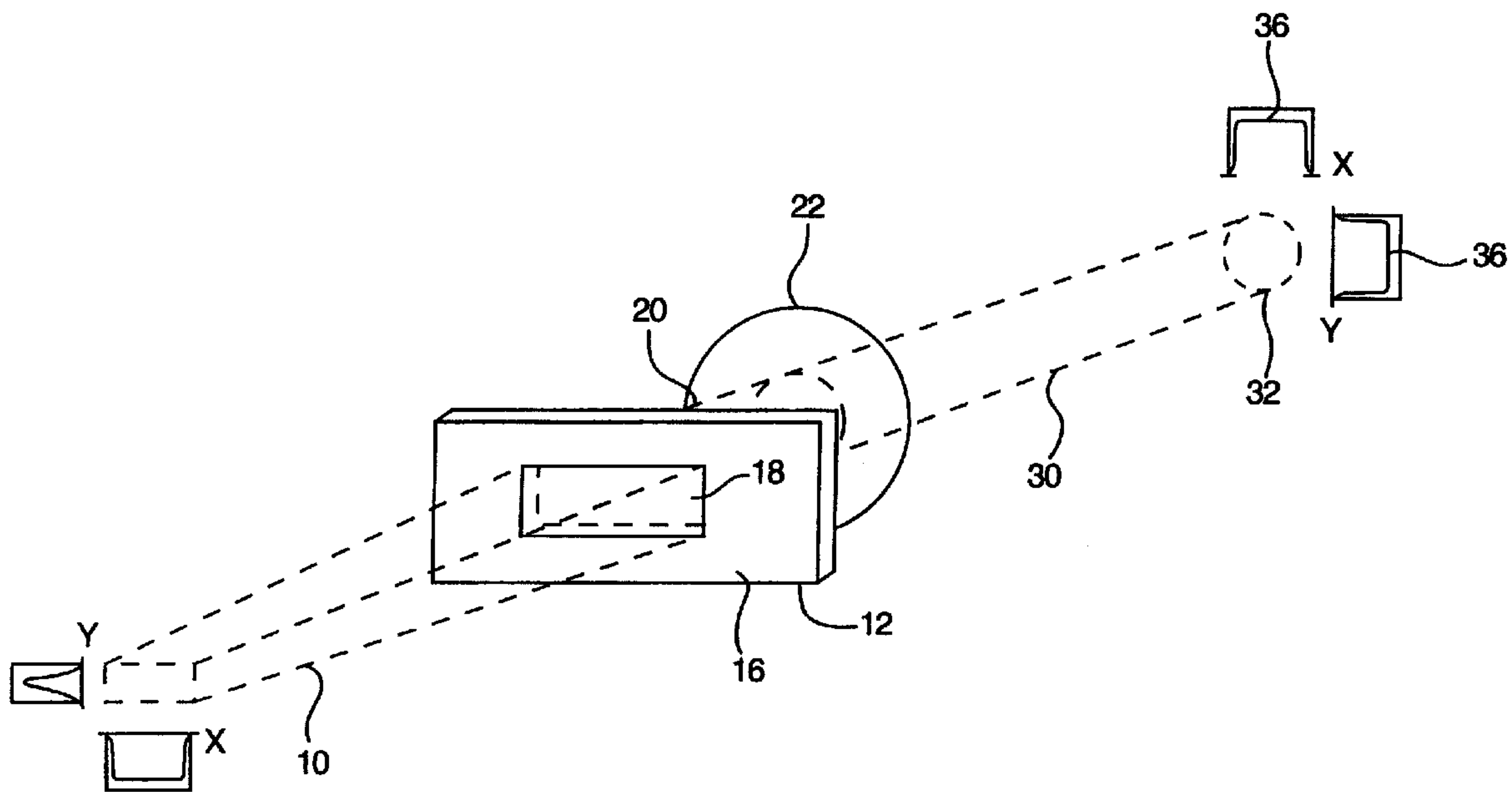

(86) Date de dépôt PCT/PCT Filing Date: 1999/01/20  
 (87) Date publication PCT/PCT Publication Date: 1999/08/05  
 (45) Date de délivrance/Issue Date: 2004/06/01  
 (85) Entrée phase nationale/National Entry: 2000/07/26  
 (86) N° demande PCT/PCT Application No.: US 1999/001281  
 (87) N° publication PCT/PCT Publication No.: 1999/039410  
 (30) Priorité/Priority: 1998/01/29 (09/015,841) US

(51) Cl.Int.<sup>6</sup>/Int.Cl.<sup>6</sup> H01S 3/08  
 (72) Inventeurs/Inventors:  
 CAUDLE, GEORGE, US;  
 LEMBERG, VLADIMIR, US  
 (73) Propriétaire/Owner:  
 VISX, INCORPORATED, US  
 (74) Agent: SMART & BIGGAR

(54) Titre : PROCÉDE ET SYSTÈME A DECHARGE PAR LASER AVEC INTEGRATION DE FAISCEAUX OPTIQUES A DIFFRACTION  
 (54) Title: LASER DELIVERY SYSTEM AND METHOD WITH DIFFRACTIVE OPTIC BEAM INTEGRATION



(57) **Abrégé/Abstract:**

A laser delivery system and method incorporate a diffractive optic beam integrator. The diffractive optic apparatus for modifying the spatial intensity distribution of an excimer laser beam (10) to generate a spatially integrated beam comprises a diffractive optic diffuser (12) and a converging lens (22). The diffractive optic diffuser (12) includes a diffractive grating pattern etched in a transparent medium for transforming the intensity profile of the excimer laser beam into a generally circular, substantially uniform spatial intensity distribution at a spatial integration plane. A variable aperture positioned about the spatial integration plane selectively passes the spatially integrated beam to an imaging lens. The imaging lens forms an image of the passed beam about a surface of a tissue to be ablated. A scanning element under computer control scans the imaged beam about the surface.

PCT

WORLD INTELLECTUAL PROPERTY ORGANIZATION  
International Bureau

## INTERNATIONAL APPLICATION PUBLISHED UNDER THE PATENT COOPERATION TREATY (PCT)-

<p>(51) International Patent Classification<sup>6</sup> : <b>H01S 3/08</b></p>	<p><b>A1</b></p>	<p>(11) International Publication Number: <b>WO 99/39410</b></p> <p>(43) International Publication Date: 5 August 1999 (05.08.99)</p>
<p>(21) International Application Number: PCT/US99/01281</p> <p>(22) International Filing Date: 20 January 1999 (20.01.99)</p> <p>(30) Priority Data: 09/015,841 29 January 1998 (29.01.98) US</p> <p>(63) Related by Continuation (CON) or Continuation-in-Part (CIP) to Earlier Application US 09/015,841 (CON) Filed on 29 January 1998 (29.01.98)</p> <p>(71) Applicant (for all designated States except US): VISX, INCORPORATED [US/US]; 3400 Central Expressway, Santa Clara, CA 95051 (US).</p> <p>(72) Inventors; and (75) Inventors/Applicants (for US only): CAUDLE, George [US/US]; 1260 Montmorency Drive, San Jose, CA 95118 (US). LEMBERG, Vladimir [IL/US]; 2545 Carlmont Drive #4, Belmont, CA 94002 (US).</p> <p>(74) Agents: BARRISH, Mark, D. et al.; Townsend and Townsend and Crew LLP, 8th floor, Two Embarcadero Center, San Francisco, CA 94111-3834 (US).</p>		<p>(81) Designated States: AL, AM, AT, AU, AZ, BA, BB, BG, BR, BY, CA, CH, CN, CU, CZ, DE, DK, EE, ES, FI, GB, GD, GE, GH, GM, HR, HU, ID, IL, IN, IS, JP, KE, KG, KP, KR, KZ, LC, LK, LR, LS, LT, LU, LV, MD, MG, MK, MN, MW, MX, NO, NZ, PL, PT, RO, RU, SD, SE, SG, SI, SK, SL, TJ, TM, TR, TT, UA, UG, US, UZ, VN, YU, ZW, ARIPO patent (GH, GM, KE, LS, MW, SD, SZ, UG, ZW), Eurasian patent (AM, AZ, BY, KG, KZ, MD, RU, TJ, TM), European patent (AT, BE, CH, CY, DE, DK, ES, FI, FR, GB, GR, IE, IT, LU, MC, NL, PT, SE), OAPI patent (BF, BJ, CF, CG, CI, CM, GA, GN, GW, ML, MR, NE, SN, TD, TG).</p> <p><b>Published</b> With international search report.</p>

(54) Title: LASER DELIVERY SYSTEM AND METHOD WITH DIFFRACTIVE OPTIC BEAM INTEGRATION

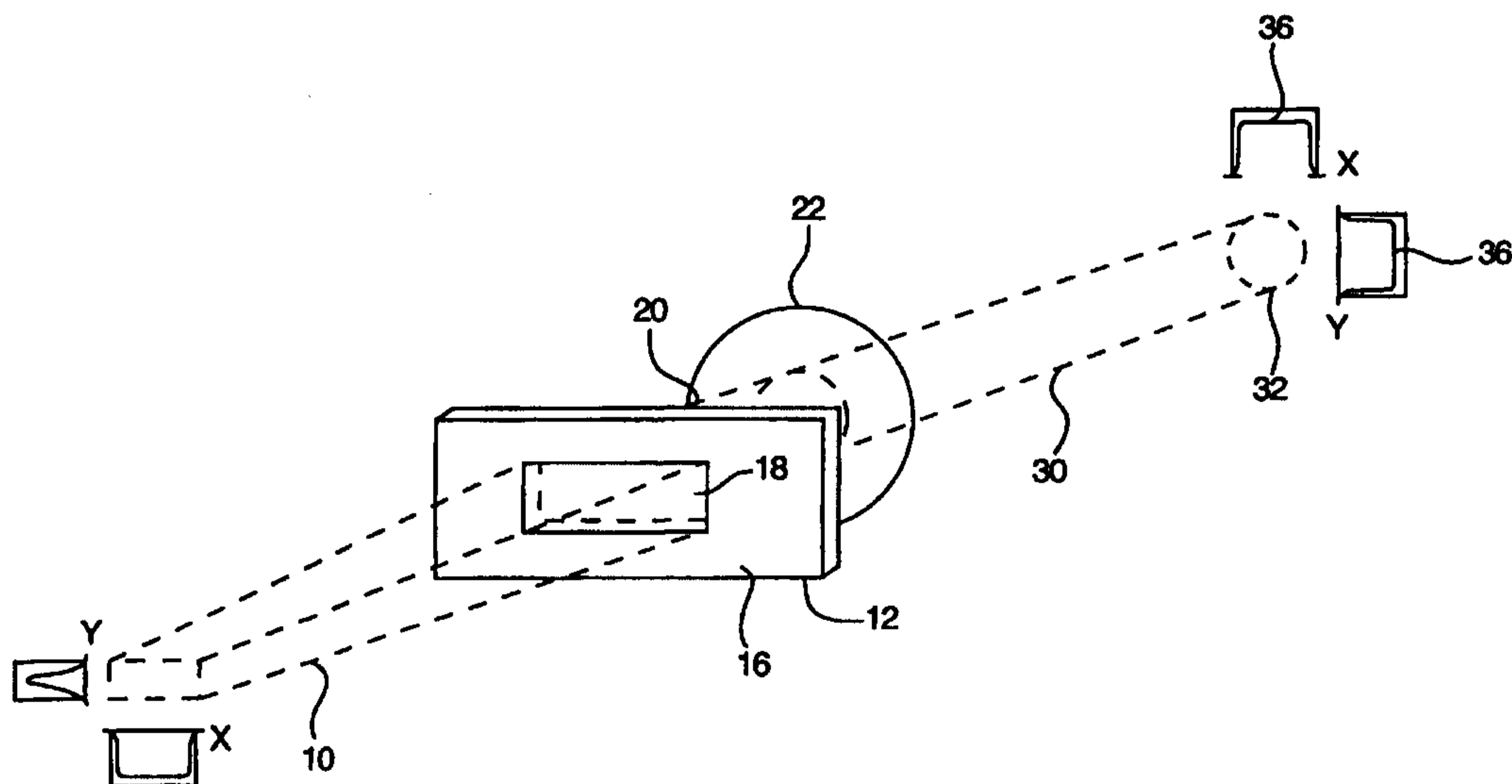

## (57) Abstract

A laser delivery system and method incorporate a diffractive optic beam integrator. The diffractive optic apparatus for modifying the spatial intensity distribution of an excimer laser beam (10) to generate a spatially integrated beam comprises a diffractive optic diffuser (12) and a converging lens (22). The diffractive optic diffuser (12) includes a diffractive grating pattern etched in a transparent medium for transforming the intensity profile of the excimer laser beam into a generally circular, substantially uniform spatial intensity distribution at a spatial integration plane. A variable aperture positioned about the spatial integration plane selectively passes the spatially integrated beam to an imaging lens. The imaging lens forms an image of the passed beam about a surface of a tissue to be ablated. A scanning element under computer control scans the imaged beam about the surface.

LASER DELIVERY SYSTEM AND METHOD  
WITH DIFFRACTIVE OPTIC BEAM INTEGRATION

FIELD OF THE INVENTION

5 This invention relates generally to light beam  
systems for modifying the spatial intensity distribution of a  
beam, and more particularly to a light beam system for  
modifying the spatial and/or temporal intensity distribution  
of an excimer laser beam to produce a beam of substantially  
10 uniform intensity for tissue ablation.

BACKGROUND OF THE INVENTION

Excimer lasers have been used for various  
applications, including tissue ablation such as corneal  
15 ablation and other surgical procedures. The cross-section of  
the intensity profile of a typical excimer laser beam is  
typically not spatially uniform. In general, the beam has a  
generally rectangular cross-section. The intensity along the  
long axis of the rectangular beam is substantially constant  
20 over the central portion of the beam. The intensity along the  
short axis of the beam is substantially gaussian. Therefore,  
the divergence of the excimer laser beam is different along  
the two axes. As a result, the beam changes shape as it is  
emitted and travels away from the excimer laser.

25 Producing a laser beam with a substantially uniform  
intensity is important in many surgical procedures such as  
tissue ablation, particularly in corneal ablation for  
refractive correction or therapeutic purposes. In addition,  
the laser beam should maintain the shape required by the  
30 ablation algorithm throughout the ablation procedure.

Various methods have been used to modify the spatial  
exposure or intensity distribution of laser beams. To  
generate a beam with more uniform intensity over the beam  
cross-section at the plane in which the ablation takes place,  
35 researchers have modified the laser discharge volume and the  
resonator optics to increase uniformity and reduce divergence  
in the beam. An aperture in a mask selects a nearly uniform  
portion of the beam by truncating the remaining portion of the

64157-599

2

beam. The aperture is imaged about an ablation plane such as the corneal plane. Alternatively, if the beam divergence is sufficiently low, the beam selected by the aperture may be projected directly to the corneal plane.

5 Another method of improving beam intensity employs complex optical systems such as a set of mirrors, prisms, or lenses to break the beam into a series of beamlets. The beamlets are overlapped in a manner to produce a uniform intensity through an aperture of a mask. The aperture is  
10 imaged onto the corneal plane.

Still another method employs a rotatable mask formed with one or more apertures having a geometric spiral shape to modify the spatial intensity distribution of a beam, as disclosed in U.S. Patent No. 5,651,784 issued to Klopotek for  
15 "ROTATABLE APERTURE APPARATUS AND METHODS FOR SELECTIVE PHOTOABLATION OF SURFACE". Temporal beam integrators, such as a rotating dove prism or k-mirror have been used to modify the laser beam to improve the average uniformity of several laser pulses over a time interval.

20 U.S. Patent No. 5,646,791 to Glockler for "METHOD AND APPARATUS FOR TEMPORAL AND SPATIAL BEAM INTEGRATION", employs a spatial beam integrator for improving the spatial uniformity of a laser beam intensity profile and a separate  
25 rotating temporal beam integrator for maintaining the uniformity of the laser beam intensity over the laser pulse time interval. The spatial beam integrator includes a plurality of prisms distributed about a hollow center. The outlet face of each prism is precisely angled with respect to  
30 the body axis of the spatial beam integrator to refract the beam towards the center. The spatial beam integrator may be stationary or rotated to generate a stationary or rotated beam with respect to the spatial beam integrator. The temporal beam integrator includes a pair of rotating cylindrical lenses  
35 spaced along the beam axis by a distance substantially equal to the sum of the focal lengths of both lenses.

U.S. Patent 5,610,733 to Feldman for "BEAM-HOMOGENIZER," and U.S. Patent 4,547,037 to Case for

64157-599

3

"HOLOGRAPHIC METHOD FOR PRODUCING DESIRED WAVEFRONT TRANSFORMATION", employ diffractive optics for changing the energy distribution of laser beams. A diffractive optical element is placed in the laser beam path at a first plane. By suitably constructing a plurality of grating patterns at the first plane, a desired output energy is generated at a second plane.

#### SUMMARY OF THE INVENTION

The prior methods of ablating tissue employ complicated and expensive apparatus to improve uniformity of the laser beam. There is a need for a simple and inexpensive apparatus capable of transforming a beam of nonuniform intensity emitted from a pulsed laser to a laser beam with substantially uniform intensity over a large portion of the cross-section of the beam. Further, embodiments of the invention provide temporal integration of the laser beam by providing means for moving the beam transforming apparatus between laser pulses.

In accordance with one aspect of the present invention, an excimer laser system for tissue ablation comprises an argon fluoride excimer laser for generating a nonuniform beam of pulsed laser energy along a path. The nonuniform beam has a nonuniform spatial intensity distribution. A diffractive optic diffuser is spaced from the laser and includes a transparent etched pattern disposed along the path of the beam for transforming the nonuniform beam into a spatially integrated beam having a substantially uniform spatial intensity distribution. A positive lens is placed about the diffractive optic diffuser for focusing the spatially integrated beam to a desired spatial intensity distribution at a spatial integration plane.

This invention employs a diffractive grating technique to modify the spatial intensity distribution of an excimer laser beam. Conventional diffractive gratings include a repetitive array of diffracting elements, with apertures or obstacles, that have the effect of producing periodic

alterations in the phase, amplitude, or both of an emergent wave such as a laser beam. One simple arrangement is an obstacle with a series of slits evenly spaced from each other. A more common diffractive grating device is a clear glass plate with ordered or random parallel notches scratched or ruled into the surface of the flat glass plate. The notches each serve as a source of scattered light and combine to form a regular array of parallel line sources. When the grating is totally transparent with negligible amplitude modulation, the regular variations in the optical thickness across the grating yield a modulation in phase. In that case, the diffractive grating device performs as transmission phase grating. In the present invention, a diffractive grating pattern etched in a transparent medium transforms an excimer laser beam into an output beam with a substantially uniform spatial intensity distribution.

Another aspect of the invention is an apparatus for spatially integrating a nonuniform argon fluoride excimer laser beam of pulsed laser energy projected along a beam axis capable of producing photoablation for tissue ablation. The apparatus comprises means disposed in the path of the nonuniform excimer beam aligned with the beam axis for diffractively diffusing the nonuniform excimer beam to generate a spatially integrated beam. The spatially integrated beam has a substantially uniform intensity distribution over the entire beam cross section. A converging lens is placed about the diffusing means and disposed in the path of the laser beam emerging from the diffusing means aligned with the beam axis. The converging lens focuses the spatially integrated beam to a desired size and spatial intensity distribution at a spatial integration plane.

Another aspect of this invention is a method of spatially integrating the nonuniform spatial intensity distribution of a nonuniform argon fluoride excimer laser beam capable of producing photoablation for ablating tissue. The method comprises the step of diffractively diffusing the nonuniform beam to obtain a diffused beam with a substantially uniform spatial intensity distribution. The diffused beam is

converged onto a spatial integration plane. The converged beam is imaged from the spatial integration plane to a plane about the tissue.

5 A further aspect of this invention is a method of spatially integrating the nonuniform spatial intensity distribution of a nonuniform argon fluoride excimer laser beam capable of producing photoablation for ablating tissue. The method comprises the step of diffractively diffusing the nonuniform beam to obtain a diffused beam with a substantially  
10 uniform spatial intensity distribution. The diffused beam is converged onto a spatial integration plane. A variable aperture positioned about the spatial integration plane selectively passes the beam. The passed beam is imaged from the spatial integration plane to a plane about the tissue.

15 A yet further aspect of this invention is a method of spatially and temporally integrating the nonuniform spatial intensity distribution of a nonuniform argon fluoride excimer laser beam capable of producing photoablation for ablating tissue. The method comprises the step of diffractively  
20 diffusing the nonuniform beam to obtain a diffused beam with a substantially uniform spatial intensity distribution. The diffused beam is converged onto a spatial integration plane. A variable aperture positioned about the spatial integration plane selectively passes the beam. The passed beam is imaged  
25 from the spatial integration plane to a plane about the tissue. Between laser pulses, a step of moving moves a diffractive element to provide temporal integration of subsequent laser pulses.

30 In accordance with another aspect of the present invention, a method of tissue ablation at a surgical plane using a nonuniform argon fluoride excimer laser beam comprises the step of diffracting the nonuniform beam to obtain a spatially integrated beam having a substantially top-hat spatial intensity distribution with a uniform portion. The  
35 spatially integrated beam is focused onto a spatially integrated plane disposed in the path of the spatially integrated beam. The size and shape of the uniform portion of the spatially integrated beam is adjusted by an aperture

positioned about the spatial integration plane. The adjusted uniform portion of the spatially integrated beam is imaged onto a plane about the surgical plane.

5 Yet another aspect of this invention is a method of spatially integrating the nonuniform intensity distribution of a nonuniform argon fluoride excimer laser beam capable of producing photoablation for ablating tissue. The comprises the step of diffractively diffusing the nonuniform beam to obtain a diffused beam with a substantially round-top spatial  
10 intensity distribution. The diffused beam is converged onto a spatial integration plane. The converged beam is imaged from the spatial integration plane to a plane about the tissue.

#### BRIEF DESCRIPTION OF THE DRAWINGS

15 Figure 1 is a perspective view schematically illustrating a diffractive optic apparatus in accordance with an embodiment of the present invention.

Figure 2 is a front elevational view schematically illustrating the diffractive optic apparatus of Figure 1.

20 Figure 3 is a perspective view schematically illustrating an embodiment of a laser beam optical delivery system incorporating the diffractive optic apparatus of Figure 1.

25 Figure 4 is a perspective view schematically illustrating another embodiment of a laser beam optical delivery system incorporating the diffractive optic apparatus of Figure 1.

Figure 5 is a block diagram of an ophthalmological surgery system for incorporating the invention.

30 Figure 6 is a plan view illustrating a scanning embodiment of the invention.

35 Figure 7 is a perspective view illustrating another embodiment of a beam profile having round-top spatial intensity distribution generated by the diffractive optic apparatus.

Figure 8 is a plan view of an embodiment with a lens ground on one surface of a diffractive element.

DESCRIPTION OF THE PREFERRED EMBODIMENT

Referring to Figures 1 and 2, a generally rectangular excimer laser beam 10 is projected along the beam axis 11 toward a diffractive element 12. The intensity along the long axis (x-axis) of the beam 10 is generally uniform, while the intensity along the short axis (y-axis) is substantially gaussian. The diffractive element 12 has a generally planar body 16 that includes a transparent portion 18 which receives and diffractively transforms the laser beam 10. The diffracted beam 20 emerging from the diffractive element 12 travels along the beam axis 11 through a positive or converging lens 22 which converges the diffracted beam 20. The converged beam 30 travels along the beam axis 11 and has a transformed pattern at a spatial integration plane 32.

Diffractive Optic Apparatus

Referring to Figure 1, the transparent portion 18 has a generally rectangular shape sized for receiving the entire rectangular beam 10. However, for beams which are not rectangular, transparent portion 18 may desirably be circular, square, or other appropriate shapes which match beam 10. The transparent portion 18 of the diffractive element 12 has a diffractive pattern etched in a transparent medium. The transparent medium may be a glass-like silica material. The transparent medium desirably is substantially non-absorbent and non-reflective to the excimer laser beam 10. For instance, the transparent medium may include fused silica, quartz, magnesium fluoride, calcium fluoride, lithium fluoride, or sapphire.

The diffractive pattern on the transparent medium forms a diffractive grating that is configured to transform the nonuniform excimer laser beam 10 to a spatially integrated excimer beam 20 with a spatial intensity distribution that is substantially uniform across the cross-section of the beam. The cross-sectional shape of the converged beam 30 may be circular or rectangular. For ophthalmological surgery such as corneal ablation, the spatial intensity distribution advantageously has a top-hat shape with a circular central

region that is substantially uniform and covers a large portion of the cross-section of the converged beam 30 (see the illustrated spatial intensity distribution at the spatial integration plane 32 of Figure 1). Other spatial intensity distributions are possible using different diffractive gratings.

The configuration of the diffractive pattern depends largely on the shape and spatial intensity distribution of the desired converged beam 30, and also on the characteristics of the incoming beam 10 such as its wavelength and spatial intensity distribution. The diffractive pattern may include a plurality of properly spaced etched regions such as lines, spots, or the like. For excimer lasers with short wavelengths in the neighborhood of about 193 nanometers (nm), the spacings of the etched regions in the diffractive pattern are advantageously small and precise. Known etching techniques such as dry etching may be used to etch the diffractive pattern on the transparent portion 18.

As illustrated in Figures 1 and 2, the converging lens 22 converges or focuses the diffracted beam 20 as the converged beam 30 to the spatial integration plane 32. The cross-section of the converged beam 30 at the spatial integration plane 32 is substantially circular and has a spatial intensity distribution with a top-hat profile. The uniform central region 36 of the intensity distribution desirably covers at least about 70%, more desirably close to 85%, of the cross-section of the beam 30. The size of the cross-section of the beam 30 at the spatial integration plane 32 is advantageously sized to correspond to the largest area ablated with a single laser pulse. For instance, a dimension across the cross-section of the beam 30 at the spatial integration plane 32 may typically range from 3 to 12 mm. Figures 1 and 2 show a planar convex lens 22, but other types of converging lenses 22 may be selected based on focal length to minimize aberration. An anti-reflective coating may be applied to prevent or minimize reflection of the beam 20 from the positive lens 22.

In operation, the laser beam 10 is directed along the beam axis 11 through the transparent portion 18 of the diffractive element 12 which is aligned with the laser beam 10 to receive the entire laser beam 10. The etched diffractive pattern of the transparent portion 18 serves as a diffractive control angle diffuser for altering the spatial intensity distribution of the laser beam 10. The transparent portion 18 transforms the generally rectangular gaussian laser beam 10 to the generally circular beam 20 with a substantially uniform intensity distribution. The positive lens 22 is aligned with the beam axis 11 and converges the spatially integrated beam 20 to a desired size. The cross-section of the converged beam 30 at the spatial integration plane 32 is substantially circular and uniform in spatial intensity, which is desirable for surgical procedures such as corneal ablation.

The diffractive element 12 and converging lens 22 spatially integrate the rectangular beam 10 to form the beam 30 having a substantially uniform intensity profile at the spatial integration plane. The cross-section of the beam 30 may be circular or rectangular, or may have other shapes. For corneal ablation, the beam 30 desirably has the uniform intensity central region 36 that covers at least about 85% of the area of the cross-section of the beam 30. The uniform intensity central region 36 includes a significant portion of the total energy of the rectangular beam 10 because there is no significant loss of energy through the diffractive optic apparatus. This renders the apparatus highly efficient.

An embodiment has been experimentally tested with satisfactory results using a 193 nm excimer laser. A binary diffractive optic 12 positioned approximately 15 mm from the converging lens 22 of 250 mm focal length produced a uniform circular beam of approximately 12 mm at the spatial integration plane 32. The binary optic employed was designed by Digital Optics Corporation of Charlotte, North Carolina. Other companies skilled in the art of diffractive optic design can produce similar gratings. The size of the spatially integrated beam at the spatial integration plane may be varied by varying the focal length of the lens 22.

Alternate embodiments of the diffractive element 12 may be employed which do not require the use of the lens 22. For example, a diffractive lens may be superimposed on the diffractive grating of the diffractive element 12. Such a diffractive element will produce a spatially integrated converted beam at the spatial integration plane 32. Alternatively, converging lens 22 may be ground on one surface of diffractive element 12, such as shown in Figure 8. In an exemplary embodiment, diffractive element 12 may be rotated between pulses to provide temporal integration of the beam.

#### Application in Ophthalmological Laser Surgery

Figure 3 illustrates the application of the invention to an ophthalmological laser surgery optical system 100 and the relative orientation of the components in the system 100. The particular components and configurations described below are merely for illustrative purposes. As discussed above, the diffractive optic apparatus can be used with a variety of different excimer laser systems.

As seen in Figure 3, a beam 102 is generated from a suitable laser source 104, such as an argon fluoride (ArF) excimer laser beam source for generating a laser beam in the far ultraviolet range with a wavelength of about 193 nm. The wavelength typically ranges from about 192.5 to about 194 nm. The laser beam 102 is directed to a beam splitter 106. A portion of the beam 102 is reflected onto an energy detector 108, while the remaining portion is transmitted through the beam splitter 106 and reflected by a mirror 110 onto a rotating temporal beam integrator 112. Another type of temporal beam integrator may be used. The rotated beam emerging from the temporal integrator 112 is directed to the diffractive optic apparatus. In a preferred embodiment, the diffractive element 12 is rotated with the beam 102. In an exemplary embodiment, the diffractive element 12 is rotated at substantially the same rate as the beam 102. The beam passes through the diffractive element 12 and positive lens 22 and emerges as the converged beam 30. The converged beam 30 travels to the spatial integration plane 32 at which a

variable aperture 116 is disposed. The spatial integration plane 32 is disposed near the focal point of the positive lens 22. An apertured beam 120 emerges from the variable aperture 116. The variable aperture 116 is desirably a variable diameter iris combined with a variable width slit (not shown) used to tailor the size and profile of the beam 30 to a particular ophthalmological surgery procedure, such as photorefractive keratectomy (PRK) and phototherapeutic keratectomy (PTK).

The apertured beam 120 is directed onto an imaging lens 122, which may be a biconvex singlet lens with a focal length of about 125 mm. The imaged beam 126 emerging from the imaging lens 122 is reflected by a mirror/beam splitter 130 onto the surgical plane 132. The apex of the cornea of the patient is typically positioned at the surgical plane 132. Imaging lens 122 may be moved transverse to the beam to offset the imaged beam in order to scan the imaged beam about the surgical plane 132. A treatment energy detector 136 senses the transmitted portion of the beam energy at the mirror/beam splitter 130. A beam splitter 138 and a microscope objective lens 140 form part of the observation optics. If desired, a beam splitter may be installed in the optical path of the beam 134 emanating from the microscope objective lens. The beam splitter is optically coupled to a video camera to assist in viewing or recording the surgical procedure. Similarly, a heads-up display may also be inserted in the optical path of the microscope objective lens 140 to provide an additional observational capability. Other ancillary components of the laser optical system 100 which are not necessary to an understanding of the invention such as the movable mechanical components driven by an astigmatism motor and an astigmatism angle motor, have been omitted to avoid prolixity.

The diffractive optic apparatus which comprises the diffractive element 12 and positive lens 22 may be used for different laser systems, including scanning laser and large area laser ablation systems. An example is the "VISX STAR Excimer Laser System", which is commercially available from VISX, Incorporated of Santa Clara, California. This system

produces an output of 193.0 nm, operates at a frequency of 6.0 Hz, and is adjusted to deliver uniform fluence of 160.0 millijoules/cm<sup>2</sup> with a 6.0 mm diameter ablation zone. Other laser systems include the T-PRK<sup>R</sup> scanning and tracking laser from Autonomous Technologies Corporation, the SVS Apex laser from Summit Technology Inc., the Keracor" 117 scanning laser system from Chiron Vision, and the like.

In an alternate embodiment, the converged beam 30 may produce a central region with a round-top spatial intensity distribution 37 at the spatial integration plane 32, as shown in Figure 7. This round-top distribution 37 may be created by varying the separation among the converging lens 22, diffractive element 12, and spatial integration plane 32. Alternatively, a different diffractive pattern on the diffractive element 12 may be employed.

The spatially integrated beam 30 may desirably be exceptionally uniform over nearly 85% of the area of the cross-section of the beam 30 during the laser pulse time interval of the beam 30. For such a spatially integrated beam 30, the temporal beam integrator 112 may be eliminated without adverse effects on the characteristics of the beam 30 and operation of the laser system 100. In that case, the diffractive optic apparatus comprising the diffractive element 12 and positive lens 22 serves as the spatial beam integrator and does not require the temporal beam integrator. Figure 4 illustrates an embodiment of the laser optic system 100 without the rotating temporal beam integrator 112 of Figure 3.

The diffractive optic apparatus is simple and inexpensive, and does not require rotation by a machine such as a motor. The diffractive element 12 and positive lens 22 can be easily aligned with the beam axis 11. The simple diffractive optic apparatus is easy to use and maintain. In an exemplary embodiment, however, the diffractive optic apparatus may be rotated to provide both spatial and temporal beam integration. The diffractive optic apparatus may be adapted for different excimer laser systems.

The ophthalmological laser surgery optical system 100 may employ the ultraviolet laser beam in corneal ablation

64157-599

13

procedures to ablate corneal tissue in a photodecomposition that does not cause thermal damage to adjacent and underlying tissue. Molecules at the irradiated surface are broken into smaller volatile fragments without heating the remaining substrate; the mechanism of the ablation is photochemical, i.e. the direct breaking of intermolecular bonds. The ablation removes a layer of the stroma to change its contour for various purposes, such as correcting myopia, hyperopia, and astigmatism. Such systems and methods are disclosed in the following U.S. patents: U.S. Pat. No. 4,665,913

issued May 19, 1987 for "METHOD FOR OPHTHALMOLOGICAL SURGERY"; U.S. Pat. No. 4,669,466 issued June 2, 1987 for "METHOD AND APPARATUS FOR ANALYSIS AND CORRECTION OF ABNORMAL REFRACTIVE ERRORS OF THE EYE"; U.S. Pat. No. 4,732,148 issued March 22, 1988 for "METHOD FOR PERFORMING OPHTHALMIC LASER SURGERY"; U.S. Pat. No. 4,770,172 issued September 13, 1988 for "METHOD OF LASER-SCULPTURE OF THE OPTICALLY USED PORTION OF THE CORNEA"; U.S. Pat. No. 4,773,414 issued September 27, 1988 for "METHOD OF LASER-SCULPTURE OF THE OPTICALLY USED PORTION OF THE CORNEA"; U.S. Patent Application Serial No. 109,812 filed October 16, 1987 for "LASER SURGERY METHOD AND APPARATUS"; U.S. Patent No. 5,163,934 issued November 17, 1992 for "PHOTOREFRACTIVE KERATECTOMY"; U.S. Patent No. 5,556,395 issued September 17, 1996 for "METHOD AND SYSTEM FOR LASER TREATMENT OF REFRACTIVE ERROR USING AN OFFSET IMAGE OF A ROTATABLE MASK"; U.S. Patent No. 5,713,892 issued February 3, 1998 for "METHOD AND APPARATUS FOR COMBINED CYLINDRICAL AND SPHERICAL EYE CORRECTIONS"; and U.S. Patent No. 6,203,539 issued March 20, 2001 for "METHOD AND SYSTEM FOR LASER TREATMENT OF REFRACTIVE ERRORS USING OFFSET IMAGING".

The block diagram of Figure 5 illustrates an ophthalmological surgery system 200 for incorporating the invention that includes a personal computer (PC) work station

202 coupled to a single board computer 204 of the laser surgery system 200 by means of a first bus connection 208. The PC work station 202 and the subcomponents of the laser surgery unit 200 are known components and may comprise the elements of the VISX TWENTY/TWENTY EXCIMER LASER SYSTEM or the VISX STAR Excimer Laser System", which are available from Visx, Incorporated of Santa Clara, California. The laser surgery system 200 includes a plurality of sensors generally designated with reference numeral 210 which produce feedback signals from the movable mechanical and optical components in the ophthalmological laser surgery optical system 100 of Figure 3 or Figure 4. The movable mechanical and optical components include, for example, the elements driven by an iris motor 216, an image rotator 218, and astigmatism width motor 220, and an astigmatism angle motor 222. For scanning treatments where an ablation from an individual laser pulse is variably offset from the treatment center, scanning motor 1 (212) and scanning motor 2 (214) are provided. The moving lens 122 transverse to the beam 120 will provide this variable offset. The feedback signals from the sensors 210 are provided via appropriate signal conductors to the single board computer 204, which is desirably an STD bus compatible single board computer using a type 8031 microprocessor. The single board computer 204 controls the operation of the motor drivers generally designated with reference numerals 226 for operating the elements 216, 218, 220, and 222. In addition, the single board computer 204 controls the operation of the excimer laser 104, which is desirably an ArF laser with a 193 nanometer wavelength output designed to provide feedback stabilized fluence of 160 milliJoules per  $\text{cm}^2$  at the cornea of the patient's eye 230 via the delivery system optics 100 of Figure 3 or Figure 4. Other ancillary components of the laser surgery system 200 which are not necessary to an understanding of the invention, such as a high resolution microscope, a video monitor for the microscope, a patient eye retention system, and an ablation effluent evacuator/filter, as well as the gas delivery system, have been omitted to avoid prolixity. Similarly, the keyboard, display, and conventional PC

subsystem components, such as flexible and hard disk drives, memory boards and the like, have been omitted from the depiction of the PC work station 202.

The laser surgery system 200 may be used for procedures such as photorefractive keratectomy (PRK) and phototherapeutic keratectomy (PTK). Using PC workstation 202, an operator enters at least one patient treatment parameter such as the desired change in patient refraction. The above treatment parameter corresponds to an improved change corneal shape. The PC workstation 202 may then calculate treatment table 260 containing the positions of the laser elements during laser treatment. The laser elements typically varied during treatment include variable aperture 116 and the position of the lens 112. In PRK, for instance, the laser surgery system 200 is used to ablate the tissue of the cornea after removal of the epithelium. To correct for myopia, the circular laser beam 30 is adjusted to a circular spot registered with the treatment area on the cornea using the adjustable aperture 116. The circular spot is typically a 0.5-6 mm circle. The correction for myopia reduces the radius of curvature of the cornea. This requires removal of more tissue in the center of the cornea and less tissue toward the peripheral treatment area. A first pulse of the apertured beam 120 can ablate away tissue from the entire treatment area, but successive pulses are reduced in diameter by the variable aperture 116 so that the pulses become successively smaller. In another embodiment, successive pulses are incrementally increased from a small to large diameter covering the treatment area. This removes more tissue from the central region and brings the cornea to the desired contour having a decreased curvature. After the photorefractive keratectomy procedure, the epithelium rapidly regrows over the shaped area, producing a new anterior surface of the cornea. Alternatively, the epithelium is not removed but is partially severed and moved to the side for surgery and returned to its original position after the PRK.

In an alternate embodiment shown in Figure 6, the treatment area 300 of the cornea comprises a plurality of

smaller areas ablated with individual laser pulses, such as the offset imaged apertured beam 126. The positions and sizes of the smaller ablated areas correspond to the values calculated in the treatment table 260. The decrease in curvature is accomplished by the scanning beam 126 about the cornea. As shown in Figure 6, the offset position 312 of the lens 122 is varied about the central position 310. This scanning produces an offset imaged apertured beam 126 with an outer portion 308. Desirably, the beam 126 covers the center 302 of the treatment area 300 during a portion of the scanning treatment. Optionally, a dimension of the variable aperture 116 may be varied during scanning to vary the size of the beam 126. In a preferred embodiment, the diffractive optic 12 is moved so as to rotate between pulses. In an exemplary embodiment, the beam rotator 112 and diffractive optic 12 are rotated between pulses. The successive pulses of the scanning beam contour the desired decreased curvature according to the treatment table 260.

For correcting hyperopia, the apertured beam 120 of Figure 3 or Figure 4 scans over a treatment area of the cornea. As shown in Figure 6, the treatment area 300 of the cornea comprises a plurality of smaller areas ablated with individual laser pulses, such as the offset imaged apertured beam 126. The positions and sizes of the smaller ablated areas correspond to the values calculated in the treatment table 260. More tissue must be removed from the periphery of the treatment area than from the center. This increases the radius of curvature of the cornea. The increase in curvature is accomplished by scanning the beam 126 about the cornea. As shown in Figure 6, the offset position 312 of the lens 122 is varied about the central position 310. This scanning produces an offset images apertured beam 126 with an outer portion 308. Desirably, the beam 126 does not cover the center 302 of the treatment area 300 during a portion of the scanning treatment. Optionally, a dimension of variable aperture 116 may be varied during scanning to vary the size of the beam 126. In a preferred embodiment, the diffractive optic 12 is moved so as to rotate between pulses. In an exemplary embodiment, the

beam rotator 112 and diffractive optic 12 are rotated between pulses. Successive pulses of the scanning beam contour the cornea to the desired increased curvature according to the treatment table 260.

5 For correcting astigmatic properties of the cornea, the variable width slit (not shown) diametrically spans the treatment area of the cornea which is generally rectangular. The first pulse of the imaged apertured beam 126 ablates away a generally rectangular area of corneal tissue. Successive  
10 pulses are directed with varying width of the generally rectangular spot of the imaged apertured beam 126 which are symmetrically positioned with respect to the optical center. The astigmatism correcting change is effected by volumetric removal of the corneal tissue.

15 While the above provides a full and complete disclosure of the preferred embodiments of the invention, various modifications, alternate constructions and equivalents may be employed as desired. For example, while the beam passed through the variable aperture 116 is offset by  
20 transverse motion of the imaging lens 122 in the preferred embodiment, other scanning elements such as rotating mirrors and prisms may be employed if desired. Further, lasers of appropriate wavelengths other than the laser 104 may be used, if desired and effective. Also, laser beam systems which  
25 operate on the principle of thermal ablations, such as lasers having wavelengths lying in the infrared portion of the electromagnetic spectrum, may be used to implement the invention. Therefore, the above description and illustrations should not be construed as limiting the invention, which is  
30 defined by the appended claims.

WHAT IS CLAIMED IS:

- 1           1.    An excimer laser system for tissue ablation  
2 comprising:  
3            an ArF excimer laser for generating a nonuniform  
4 beam of pulsed laser energy along a path, the nonuniform  
5 beam having a nonuniform spatial intensity distribution;  
6            a diffractive optic diffuser spaced from the laser  
7 and including a transparent diffractive pattern disposed  
8 along the path of the beam for transforming the  
9 nonuniform beam into a spatially integrated beam having a  
10 substantially uniform spatial intensity distribution; and  
11            a positive lens positioned about the diffractive  
12 optic diffuser for focusing the spatially integrated beam  
13 onto a spatial integration plane.
- 1           2.    The excimer laser system of Claim 1, wherein  
2 the nonuniform beam has a wavelength of about 193 nm.
- 1           3.    The excimer laser system of Claim 1, wherein  
2 the nonuniform beam is generally rectangular with a  
3 substantially gaussian spatial intensity distribution along  
4 one axis.
- 1           4.    The excimer laser system of Claim 1, wherein  
2 the spatially integrated beam has a substantially rectangular  
3 uniform pattern across a cross-section of the spatially  
4 integrated beam.
- 1           5.    The excimer laser system of Claim 1, wherein  
2 the spatially integrated beam has a substantially circular  
3 uniform pattern across the cross-section of the spatially  
4 integrated beam.
- 1           6.    The excimer laser system of Claim 5, wherein  
2 the circular uniform pattern has a top-hat profile with a  
3 uniform central region.

1           7. The excimer laser system of Claim 6, wherein  
2 the uniform central region covers at least about 70% of the  
3 cross-section of the spatially integrated beam.

1           8. The excimer laser system of Claim 7, wherein  
2 the spatially integrated central region covers nearly 85% of  
3 the cross-section of the spatially integrated beam over a  
4 laser pulse time interval.

1           9. The excimer laser system of Claim 1, wherein  
2 the transparent diffractive pattern includes a transparent  
3 portion with a plurality of spaced etched areas.

1           10. The excimer laser system of Claim 9, wherein  
2 the plurality of spaced etched areas comprise a plurality of  
3 spaced etched lines.

1           11. The excimer laser system of Claim 9, wherein  
2 the transparent portion is generally rectangular.

1           12. The excimer laser system of Claim 9, wherein  
2 the transparent portion includes a transparent material.

1           13. The excimer laser system of Claim 12, wherein  
2 the transparent material is selected from the group consisting  
3 of quartz, fused silica, magnesium fluoride, calcium fluoride,  
4 lithium fluoride, and sapphire.

1           14. The excimer laser system of Claim 1, wherein  
2 the positive lens is ground on one surface of the diffractive  
3 optic diffuser.

1           15. The excimer laser system of Claim 1, wherein  
2 the spatial integration plane is disposed about the focal  
3 point of the positive lens.

1           16. An apparatus for spatially integrating a  
2 nonuniform ArF excimer laser beam of pulsed laser energy

3 projected along a beam axis capable of producing photoablation  
4 for tissue ablation, the apparatus comprising:

5 means disposed in the path of the nonuniform excimer  
6 beam aligned with the beam axis for diffractively  
7 diffusing the nonuniform excimer beam to generate a  
8 spatially integrated excimer beam with a substantially  
9 uniform intensity distribution over the spatially  
10 integrated excimer beam; and

11 a converging lens positioned about the diffusing  
12 means and disposed in the path of the excimer beam and  
13 aligned with the beam axis, the converging lens focusing  
14 the excimer beam to a spatial integration plane.

1 17. The apparatus of Claim 16, wherein the  
2 diffusing means comprises a diffractive optic diffuser having  
3 a diffractive grating pattern.

1 18. The apparatus of Claim 17, wherein the  
2 diffractive grating pattern comprises a plurality of spaced  
3 regions etched in a transparent medium that is substantially  
4 non-absorbent and non-reflective of the nonuniform excimer  
5 beam.

1 19. The apparatus of Claim 17, wherein the  
2 transparent medium comprises silica.

1 20. The apparatus of Claim 17, wherein the  
2 plurality of spaced regions comprise closely spaced lines.

1 21. The apparatus of Claim 17, wherein the  
2 diffractive optic diffuser transforms the intensity  
3 distribution of the nonuniform excimer beam from a generally  
4 rectangular beam with a gaussian intensity along one axis to a  
5 substantially circular beam with a uniform intensity over the  
6 cross-section of the spatially integrated excimer beam.

1 22. The apparatus of Claim 16, wherein the  
2 substantially uniform intensity distribution has a uniform

3 central region covering at least about 70% of the cross-  
4 section of the spatially integrated excimer beam.

1 23. The apparatus of Claim 22, wherein the uniform  
2 central region covers nearly 85% of the cross-section of the  
3 spatially integrated excimer beam over a laser pulse time  
4 interval.

1 24. A method of spatially integrating the  
2 nonuniform spatial intensity distribution of a nonuniform ArF  
3 excimer laser beam capable of producing photoablation for  
4 ablating a tissue, the method comprising the steps of:

5 diffractionally diffusing the nonuniform beam to  
6 obtain a diffused beam with a substantially uniform  
7 spatial intensity distribution;

8 converging the diffused beam to a desired spatial  
9 integration at a first plane; and

10 imaging the converged beam from the first plane to a  
11 second plane about the tissue.

1 25. The method of Claim 24, wherein the step of  
2 diffusing includes directing the nonuniform beam through a  
3 transparent diffractive pattern.

1 26. The method of Claim 25, wherein the transparent  
2 diffractive pattern includes a plurality of spaced portions  
3 etched in a substantially non-absorbent transparent medium.

1 27. The method of Claim 24, wherein the  
2 substantially uniform spatial intensity distribution includes  
3 a top-hat pattern having a uniform central portion over at  
4 least about 85% of the cross-section of the uniform beam.

1 28. The method of Claim 27, wherein the uniform  
2 central portion covers about 85% of the cross-section of the  
3 diffused beam.

1           29. The method of Claim 24, further comprising the  
2 step of passing the converged beam through a variable aperture  
3 imaged about the tissue.

1           30. A method of tissue ablation at a surgical plane  
2 using a nonuniform ArF excimer laser beam comprising the steps  
3 of:

4           diffracting the nonuniform beam to obtain a  
5 spatially integrated beam having a substantially top-hat  
6 spatial intensity distribution with a uniform portion;  
7           focusing the spatially integrated beam onto a first  
8 plane disposed in the path of the spatially integrated  
9 beam;

10          adjusting a dimension of the uniform portion of the  
11 spatially integrated beam; and

12          imaging the adjusted uniform portion of the  
13 spatially integrated beam to a second plane about the  
14 surgical plane.

1           31. The method of Claim 30, wherein the step of  
2 diffracting comprises diffractively diffusing the nonuniform  
3 beam with a diffractive grating.

1           32. The method of Claim 31, wherein the diffractive  
2 grating includes a plurality of lines etched in a transparent  
3 medium.

1           33. The method of Claim 32, wherein the transparent  
2 medium includes a substantially non-reflective and non-  
3 absorbent silica material.

1           34. The method of Claim 30, wherein the step of  
2 focusing comprises directing the beam through a converging  
3 lens.

1           35. The method of Claim 34, wherein the first plane  
2 is disposed about the focal point of the converging lens.

1           36. The method of Claim 30, wherein the step of  
2 adjusting comprises directing the spatially integrated beam  
3 with the uniform portion through an adjustable aperture having  
4 a maximum size approximately equal to the size of the uniform  
5 portion.

1           37. The method of Claim 30, wherein the step of  
2 adjusting comprises directing the spatially integrated beam  
3 with the uniform portion through an adjustable aperture  
4 defining a slit.

1           38. The method of Claim 30, wherein the uniform  
2 portion of the substantially top-hat distribution covers at  
3 least about 85% of the cross-section of the spatially  
4 integrated beam.

1           39. The method of Claim 38, wherein the uniform  
2 portion of the substantially top-hat distribution covers about  
3 85% of the cross-section of the spatially integrated beam.

1           40. A laser system for reshaping the cornea of an  
2 eye, the system comprising:  
3           a pulsed laser for generating a nonuniform beam of  
4 pulsed laser energy along a path, the nonuniform beam  
5 having a nonuniform spatial intensity distribution;  
6           a diffractive optic disposed along the path of the  
7 beam for profiling the nonuniform beam into a spatially  
8 integrated beam having a desired spatial intensity  
9 distribution at a first plane;  
10           an aperture spaced from the diffractive optic about  
11 the first plane for passing an area of the profiled beam;  
12 and  
13           a positive lens spaced from the aperture to form an  
14 image of the passed beam at a second plane about the  
15 cornea.

1           41. The laser system of Claim 40, wherein the  
2 nonuniform beam has a wavelength of about 193 nm.

1           42. The laser system of Claim 40, wherein the  
2 pulsed laser is an excimer laser.

1           43. The laser system of Claim 40, wherein the  
2 nonuniform beam has a generally rectangular gaussian spatial  
3 intensity distribution and the spatially integrated beam has a  
4 substantially circular uniform pattern across the cross-  
5 section of the spatially integrated beam.

1           44. The laser system of Claim 40, further  
2 comprising a scanning element for displacing the image of the  
3 passed beam.

1           45. The laser system of Claim 44, wherein the  
2 scanning element displaces the image according to a treatment  
3 table.

1           46. The laser system of Claim 45, wherein the  
2 diffractive optic moves between laser pulses.

1           47. The laser system of Claim 46, wherein the  
2 movement of the diffractive optic comprises rotation.

1           48. The laser system of Claim 47, wherein a  
2 dimension of the aperture varies between laser pulses.

1           49. The laser system of Claim 48, wherein the  
2 pulsed laser is an excimer laser.

1           50. The laser system of Claim 49, wherein the  
2 excimer laser has a wavelength of about 193 nm.

1           51. A method of reshaping a cornea of an eye from  
2 an initial shape to an improved shape, the method comprising  
3 the steps of:

4           inputting at least one parameter relating to the  
5 improved shape of the eye;

6           calculating a treatment table corresponding to the  
7           improved shape;  
8           pulsing a laser to produce a laser beam;  
9           diffracting the pulsed laser beam to produce a  
10          spatially integrated beam;  
11          passing the diffracted beam through an aperture  
12          about a spatial integration plane;  
13          imaging the passed beam; and  
14          offsetting the imaged beam about a central position  
15          to produce an ablation corresponding to the treatment  
16          table.

1           52. The method of Claim 51, wherein the step of  
2           pulsing produces ultraviolet light.

1           53. The method of Claim 52, wherein the step of  
2           passing further comprises changing a dimension of the  
3           aperture.

1           54. The method of Claim 53, further comprising the  
2           step of viewing the cornea through an operating microscope  
3           objective lens.

1           55. The method of Claim 54, wherein the step of  
2           diffracting further comprises rotating the pulsed laser beam  
3           to provide temporal integration.

1           56. The method of Claim 51, wherein the step of  
2           diffracting further comprises producing a spatially integrated  
3           beam with a substantially top-hat spatial intensity  
4           distribution.

1           57. The method of Claim 51, wherein the step of  
2           diffracting further comprises producing a spatially integrated  
3           beam with a substantially round-top spatial intensity  
4           distribution.

1           58. A laser system for reshaping the cornea of an  
2 eye, the system comprising:

3           a pulsed laser for generating a nonuniform beam of  
4 pulsed laser energy along a path, the nonuniform beam  
5 having a nonuniform spatial intensity distribution;

6           a diffractive optic disposed along the path of the  
7 beam for profiling the nonuniform beam into a spatially  
8 integrated beam having a substantially round-top spatial  
9 intensity distribution at a first plane;

10          an aperture spaced from the diffractive optic about  
11 the first plane for passing an area of the profiled beam;  
12 and

13          a positive lens spaced from the aperture to form an  
14 image of the passed beam at a second plane about the  
15 cornea.

1           59. The laser system of Claim 58, wherein the  
2 nonuniform beam has a wavelength of about 193 nm.

1           60. The laser system of Claim 59, wherein the  
2 pulsed laser is an excimer laser.

1           61. The laser system of Claim 60, further  
2 comprising a scanning element for displacing the image of the  
3 passed beam.

1           62. The laser system of Claim 61, wherein the  
2 scanning element displaces the image according to a treatment  
3 table.

1           63. The laser system of Claim 60, wherein the  
2 diffractive optic moves between laser pulses.

1           64. The laser system of Claim 63, wherein the  
2 movement of the diffractive optic comprises rotation.

1           65. The laser system of Claim 64, wherein a  
2 dimension of the aperture varies between laser pulses.

1           66. The laser system of Claim 60, further  
2 comprising a second lens positioned about the diffractive  
3 optic for converging the spatially integrated beam to a  
4 desired size at the spatial integration plane.

1           67. The laser system of Claim 66, wherein the  
2 second lens is ground on one surface of the diffractive optic.

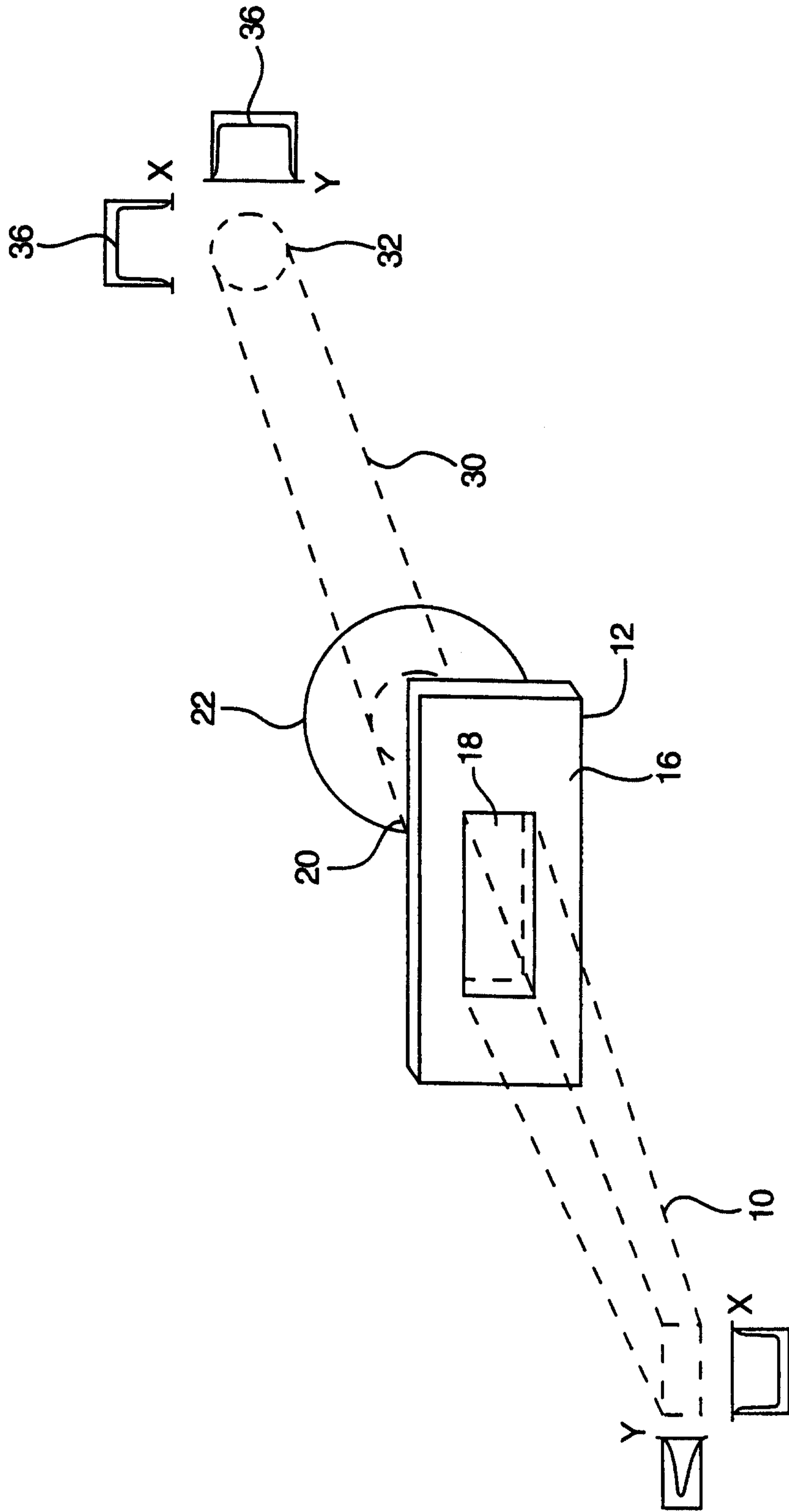

FIG. 1

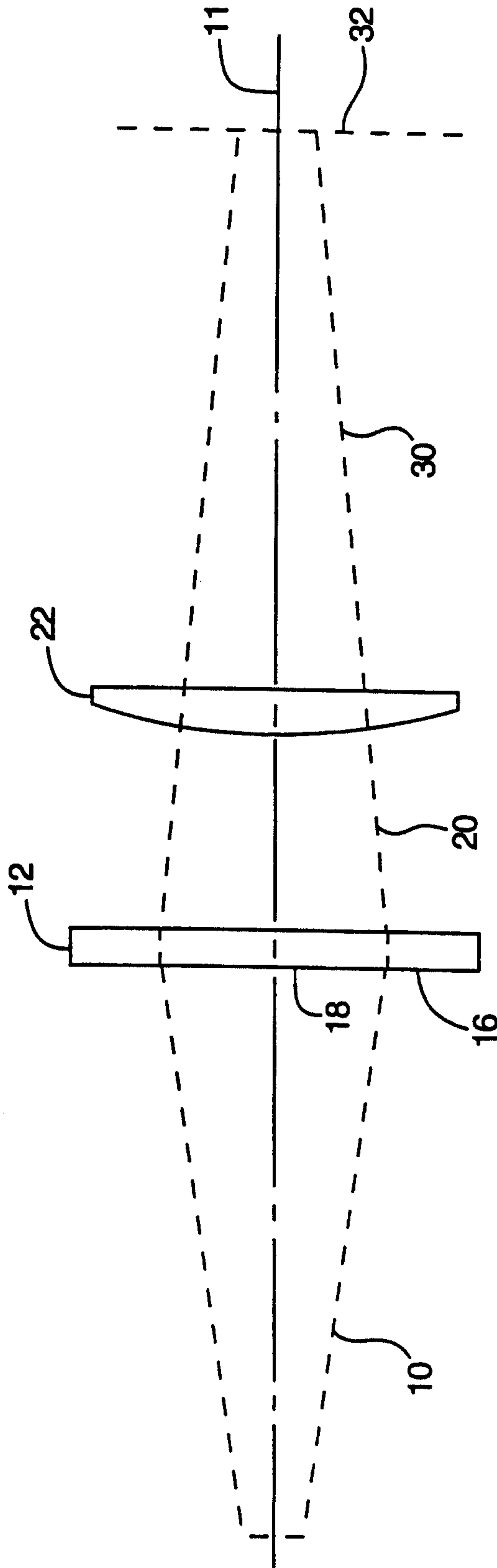

FIG. 2

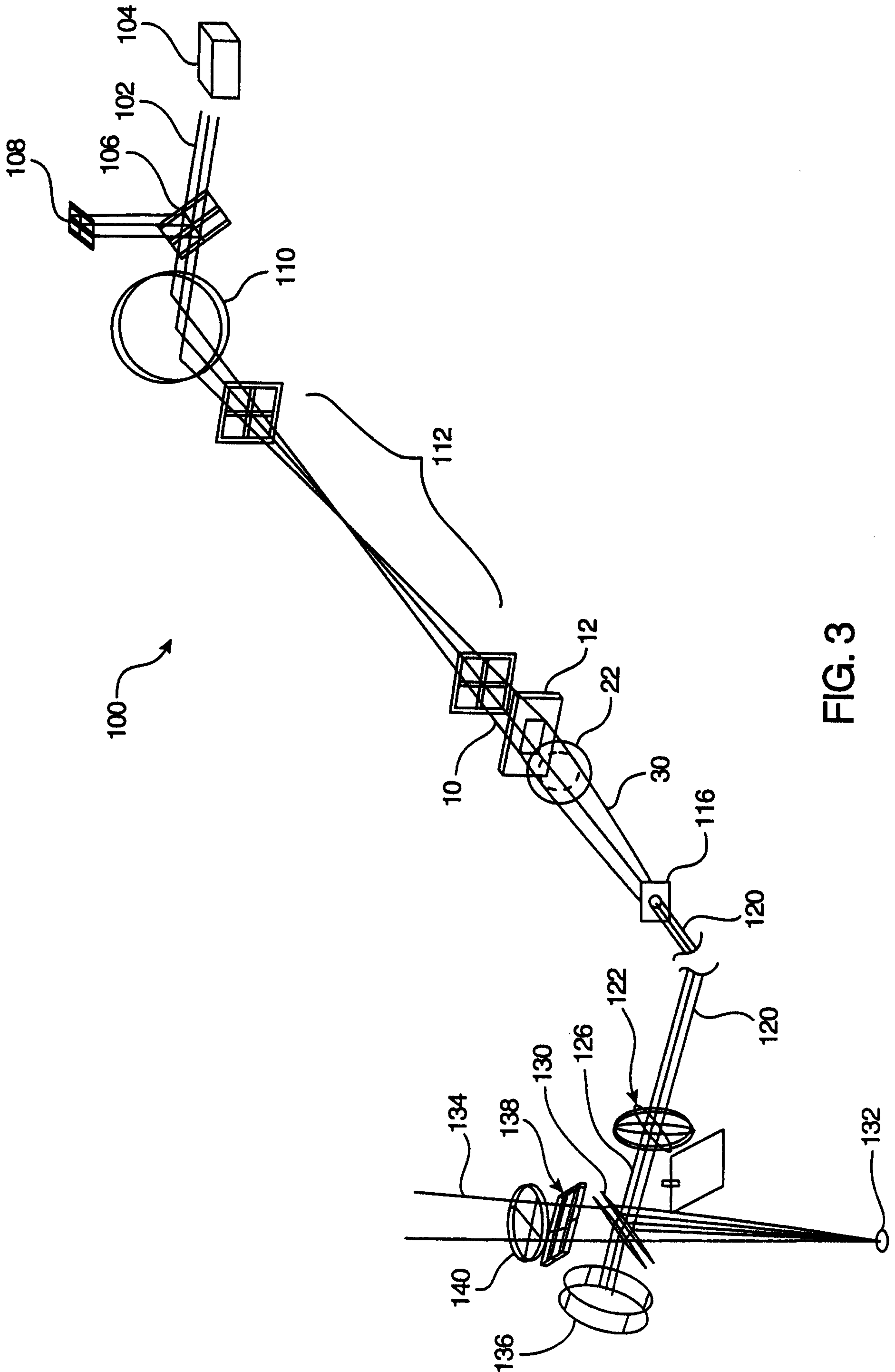

FIG. 3

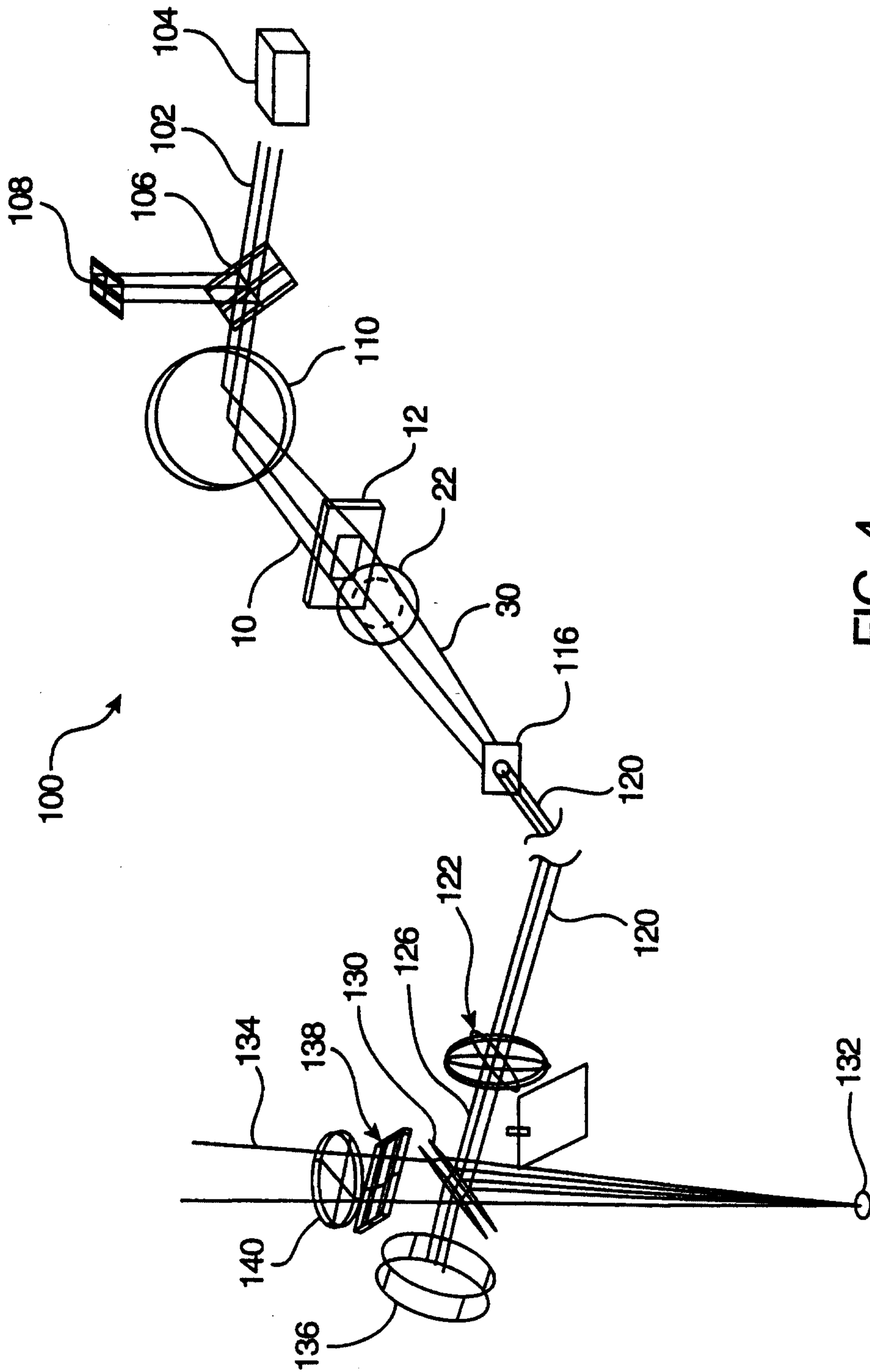

FIG. 4

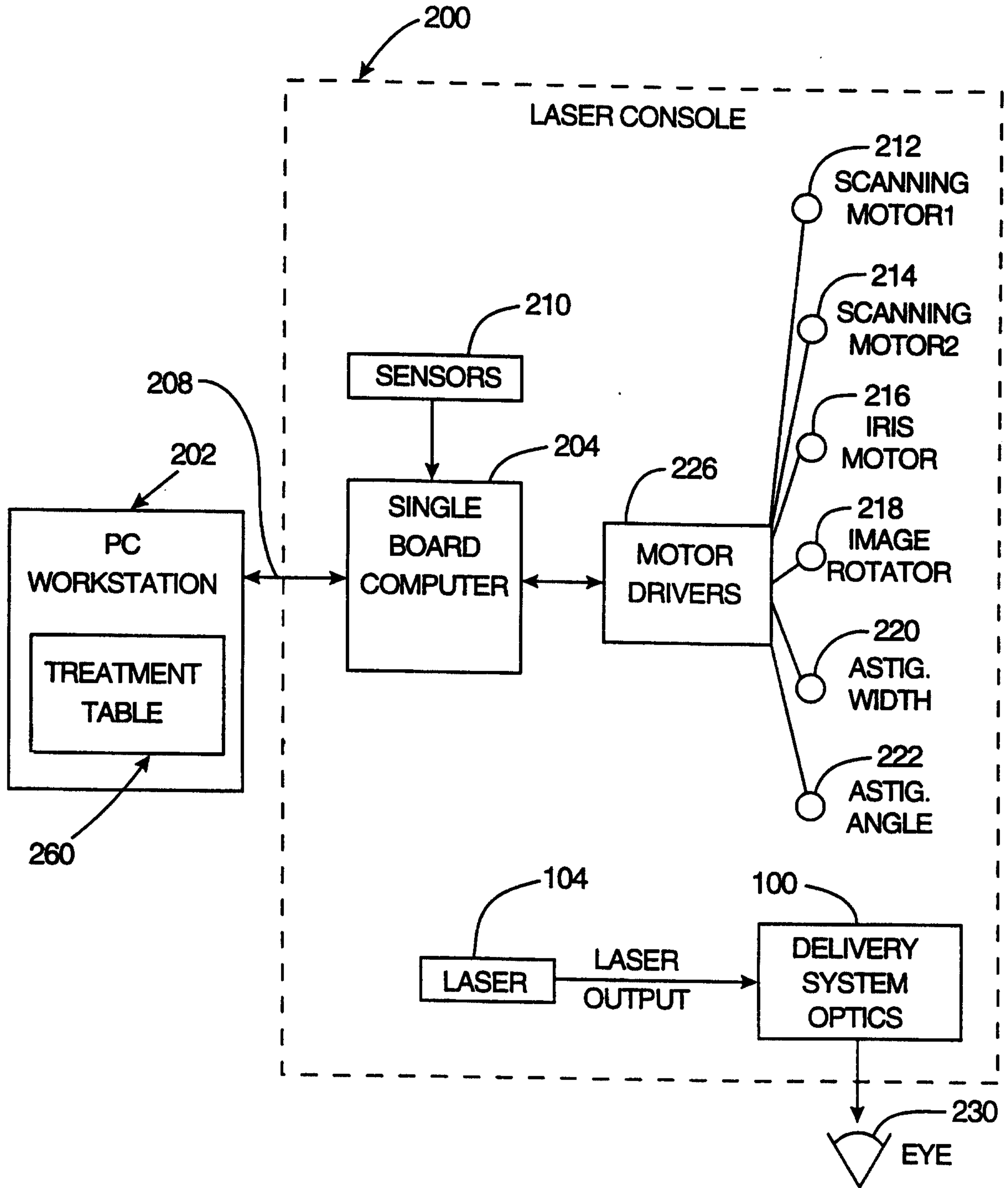

FIG. 5

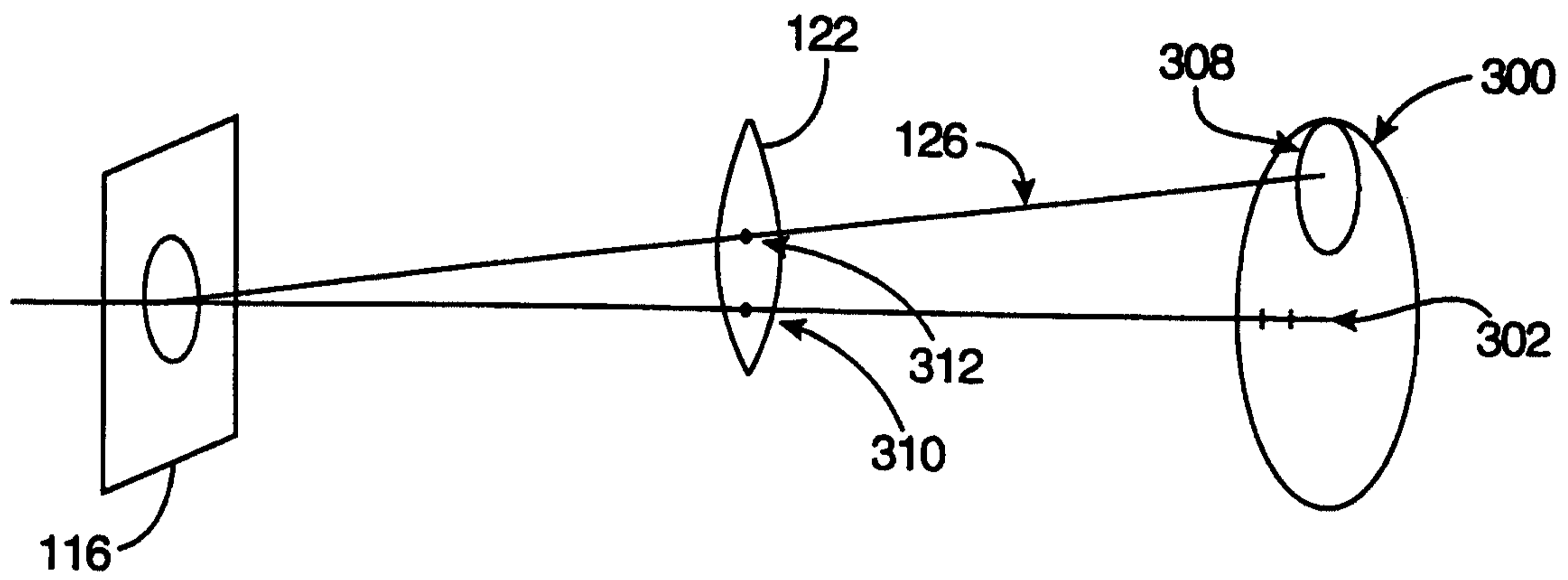

FIG. 6

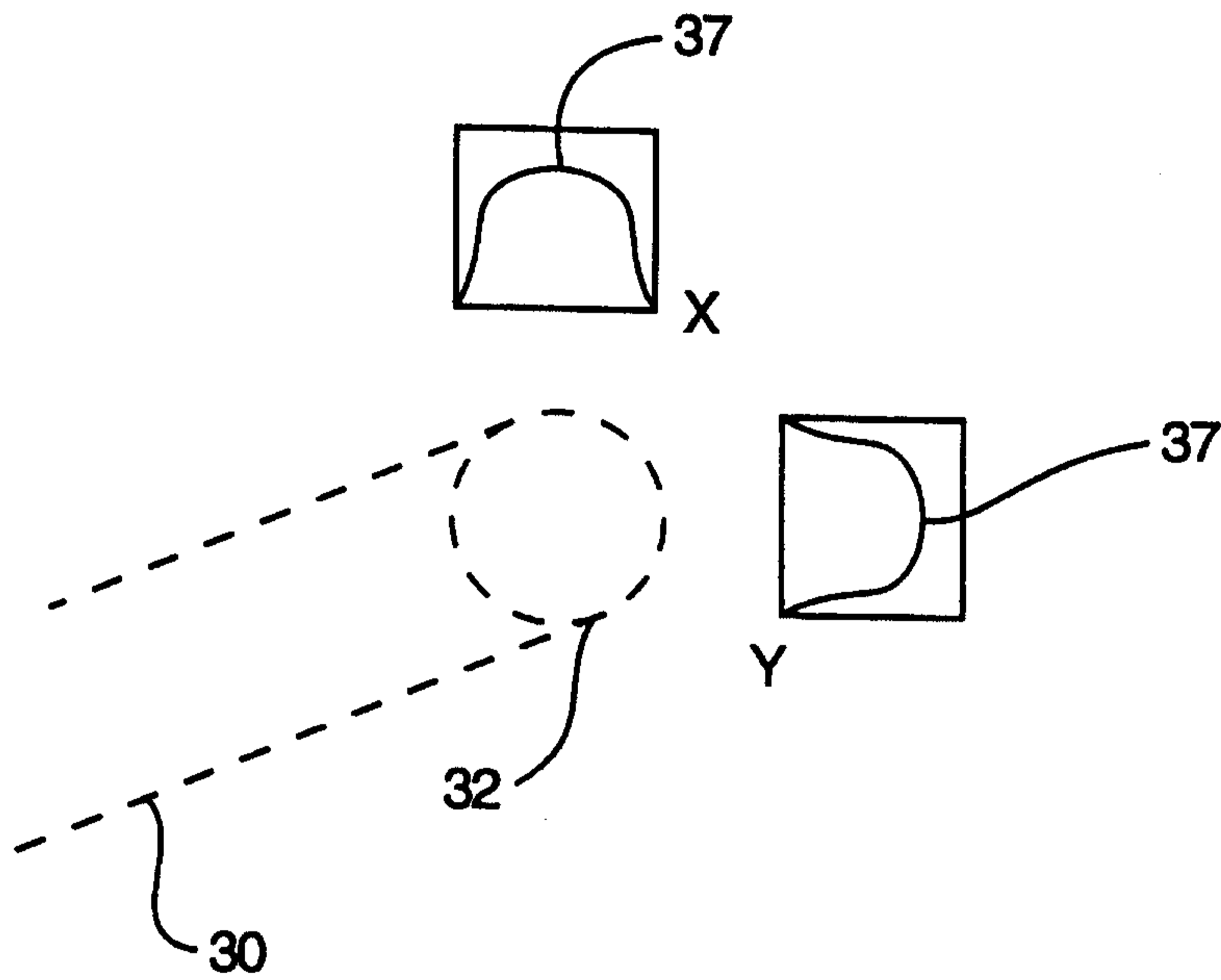

FIG. 7

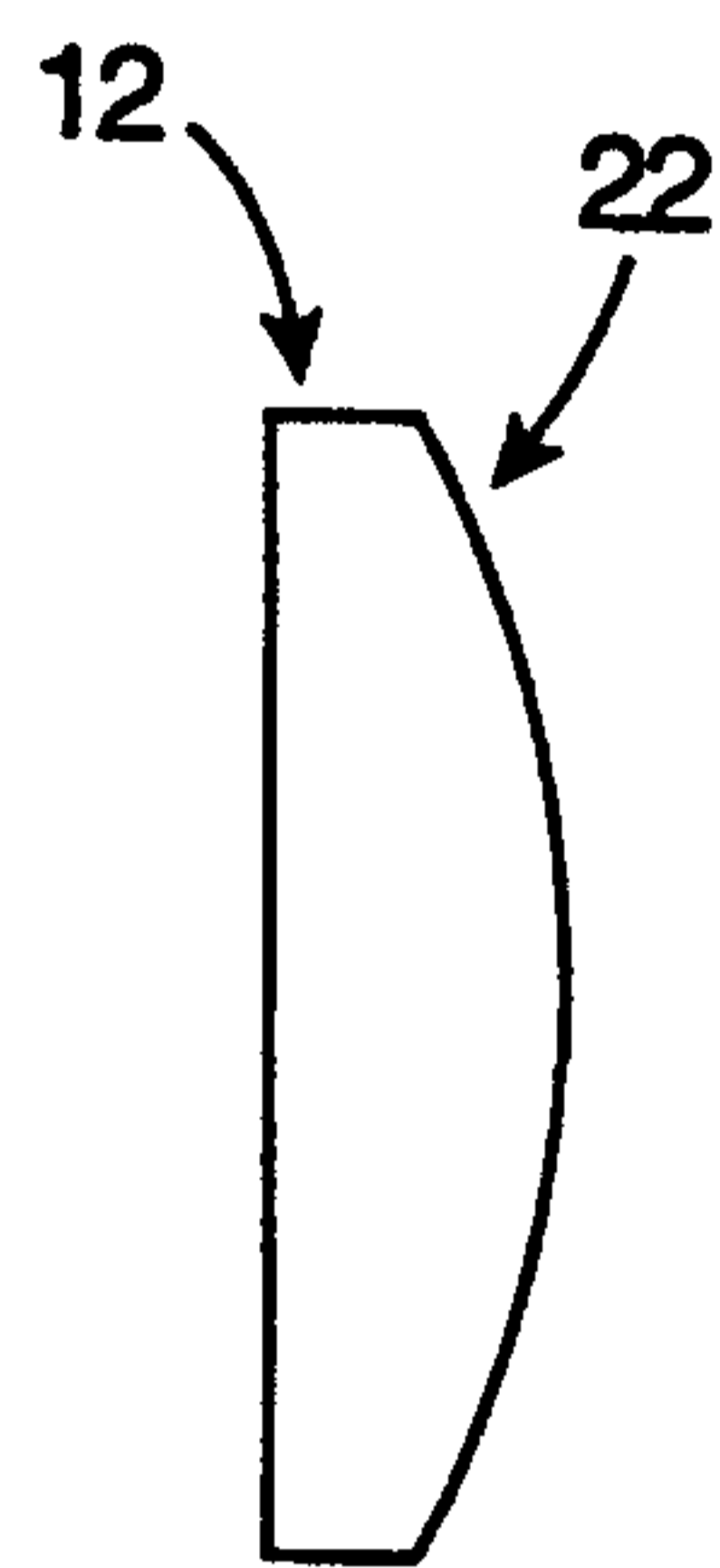

FIG. 8

