



(19) **United States**

(12) **Patent Application Publication**
Lochtman et al.

(10) **Pub. No.: US 2009/0178930 A1**

(43) **Pub. Date: Jul. 16, 2009**

(54) **ELECTROPLATING DEVICE AND METHOD**

Publication Classification

(75) Inventors: **Rene Lochtman**, Mannheim (DE);
Jürgen Kaczun, Wachenheim (DE);
Norbert Schneider, Altrip (DE);
Jürgen Pfister, Speyer (DE);
Gert Pohl, Sindelfingen (DE);
Norbert Wagner, Mutterstadt (DE)

(51) **Int. Cl.**
C25D 5/00 (2006.01)
C25D 17/00 (2006.01)
(52) **U.S. Cl.** **205/80; 204/212**

Correspondence Address:
CONNOLLY BOVE LODGE & HUTZ, LLP
P O BOX 2207
WILMINGTON, DE 19899 (US)

(57) **ABSTRACT**

The invention relates to a device for the electrolytic coating of at least one electrically conductive substrate or a structured or full-surface electrically conductive surface on a nonconductive substrate, which comprises at least one bath, one anode and one cathode, the bath containing an electrolyte solution containing at least one metal salt, from which metal ions are deposited on electrically conductive surfaces of the substrate to form a metal layer while the cathode is brought in contact with the substrate's surface to be coated and the substrate is transported through the bath, wherein the cathode comprises at least two disks (2, 4, 10) mounted on a respective shaft (1, 5, 14) so that they can rotate, the disks (2, 4, 10) engaging in one another. The invention furthermore relates to a method for the electrolytic coating of at least one substrate, which is carried out in a device according to the invention. Lastly, the invention also relates to a use of the device according to the invention for the electrolytic coating of electrically conductive structures on an electrically nonconductive support.

(73) Assignee: **BASF SE**, Ludwigshafen (DE)

(21) Appl. No.: **12/297,330**

(22) PCT Filed: **Apr. 5, 2007**

(86) PCT No.: **PCT/EP2007/053401**

§ 371 (c)(1),
(2), (4) Date: **Oct. 16, 2008**

(30) **Foreign Application Priority Data**

Apr. 18, 2006 (EP) 06112724.7

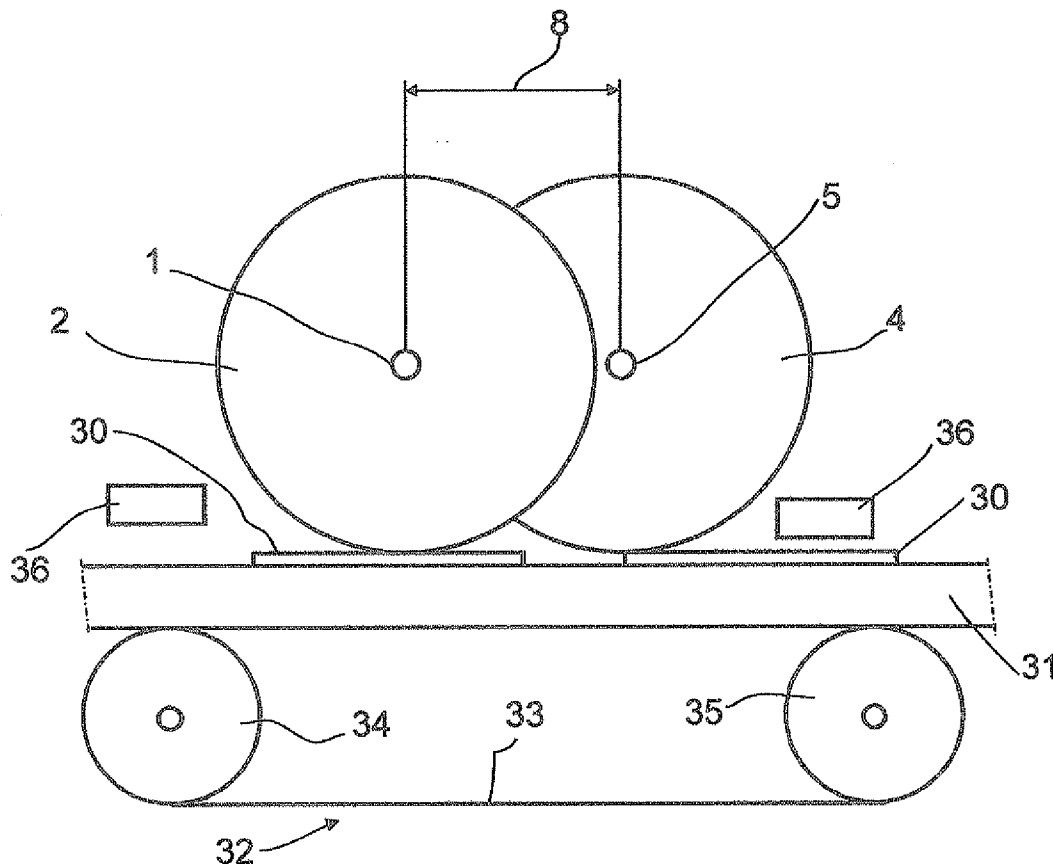

FIG. 1

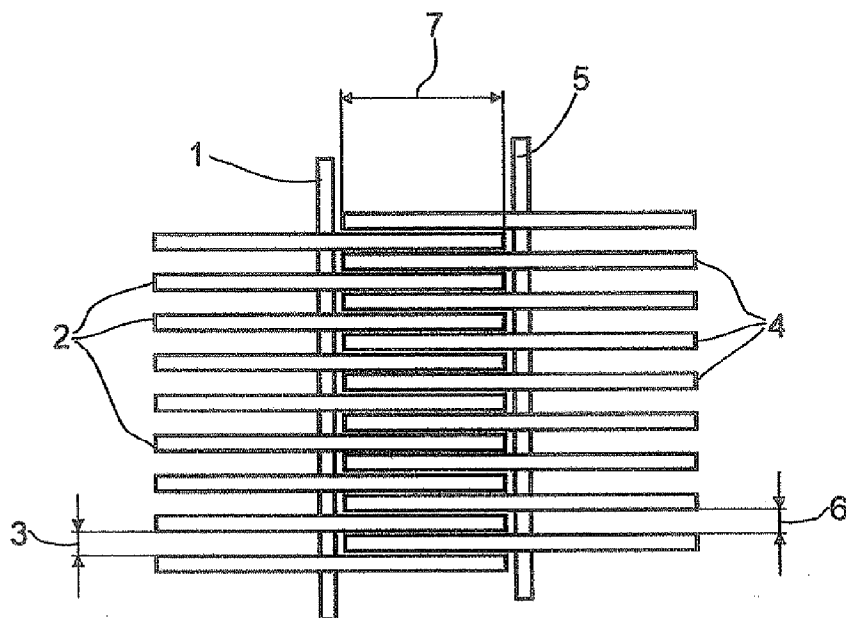

FIG. 2

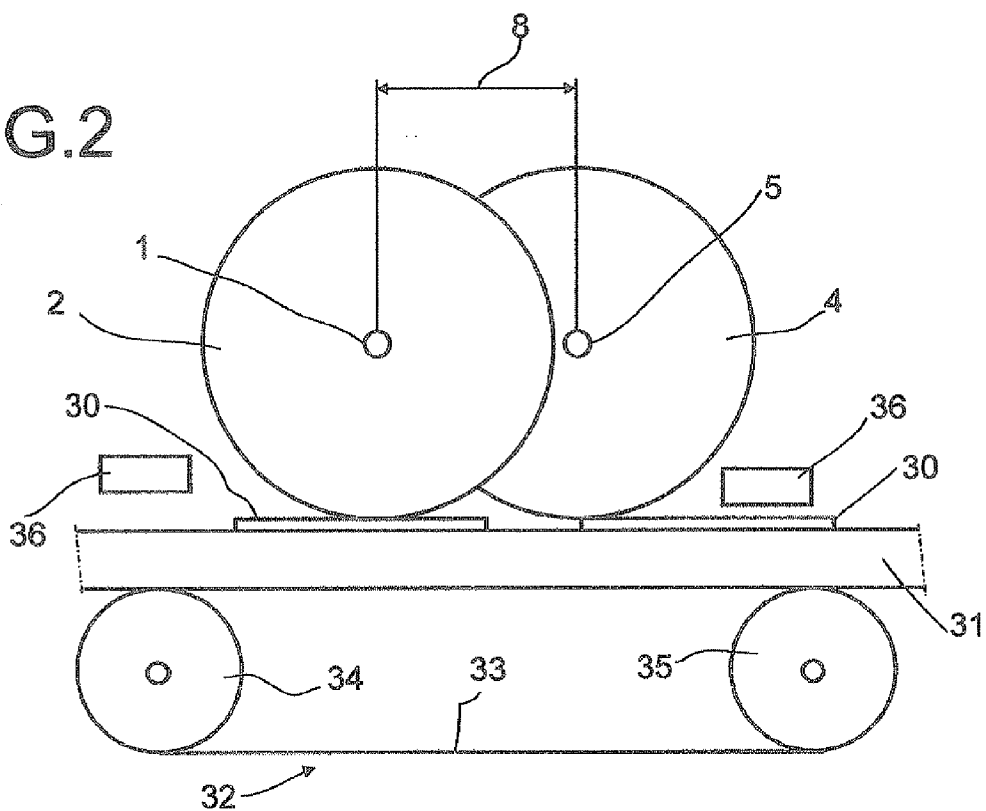

FIG. 3

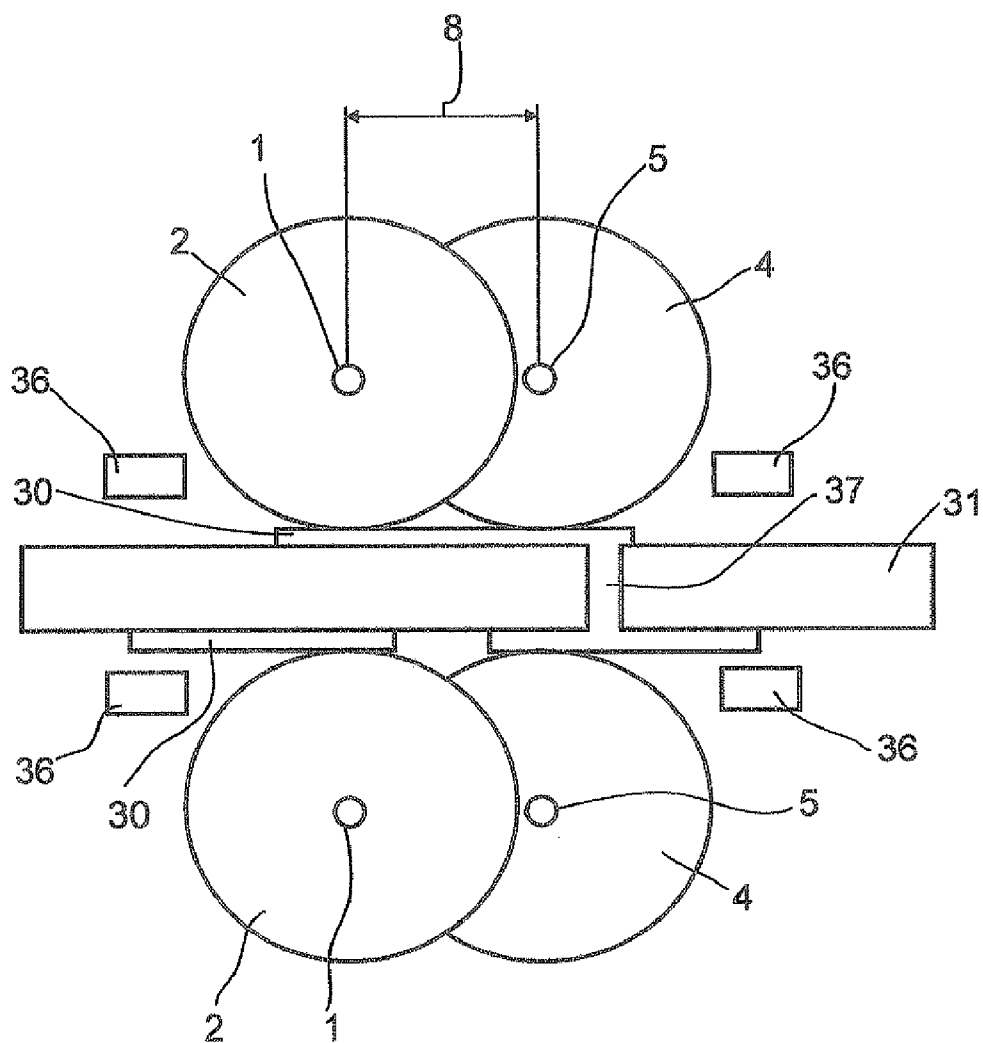

FIG.4

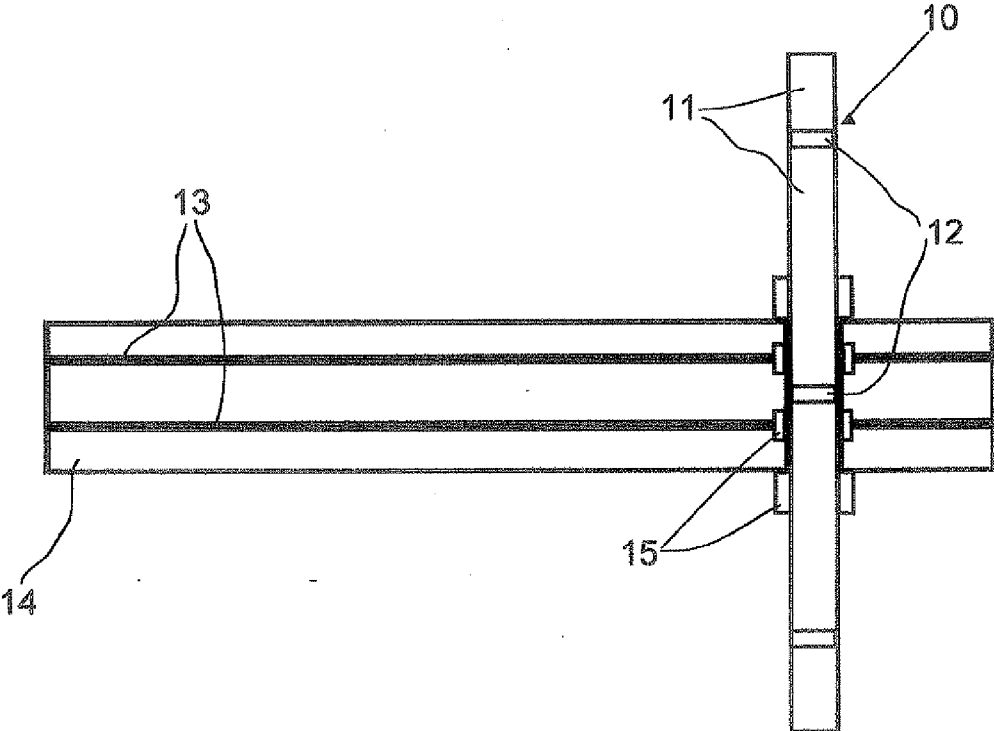

FIG.5

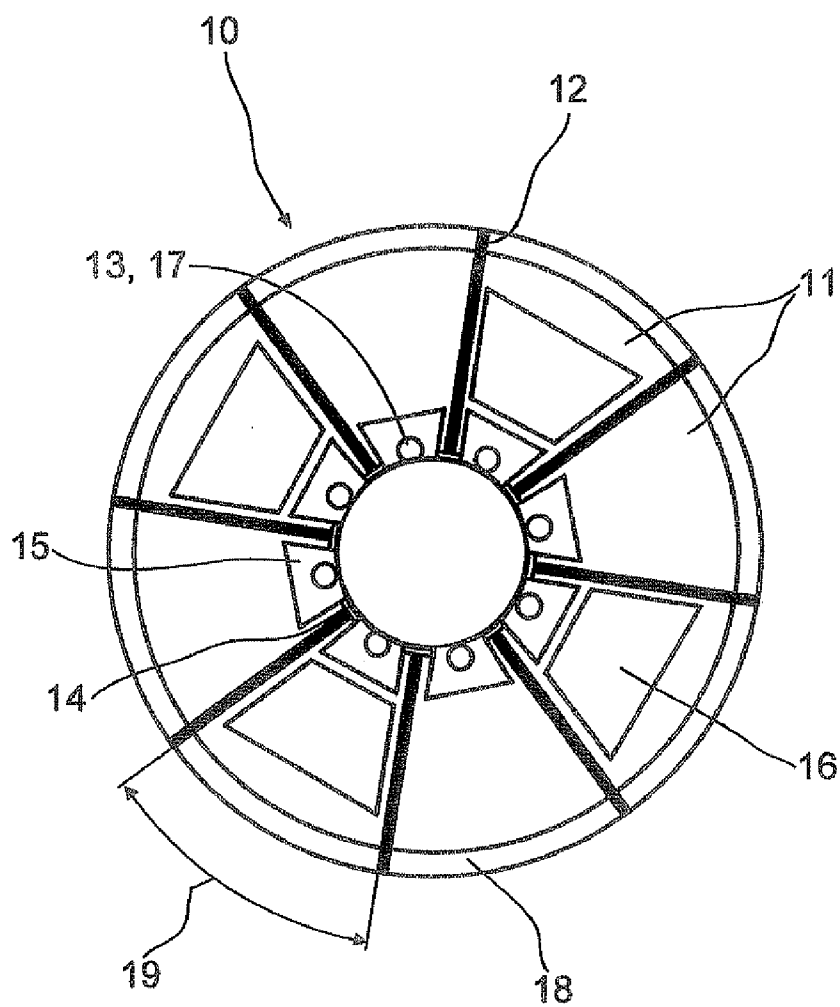
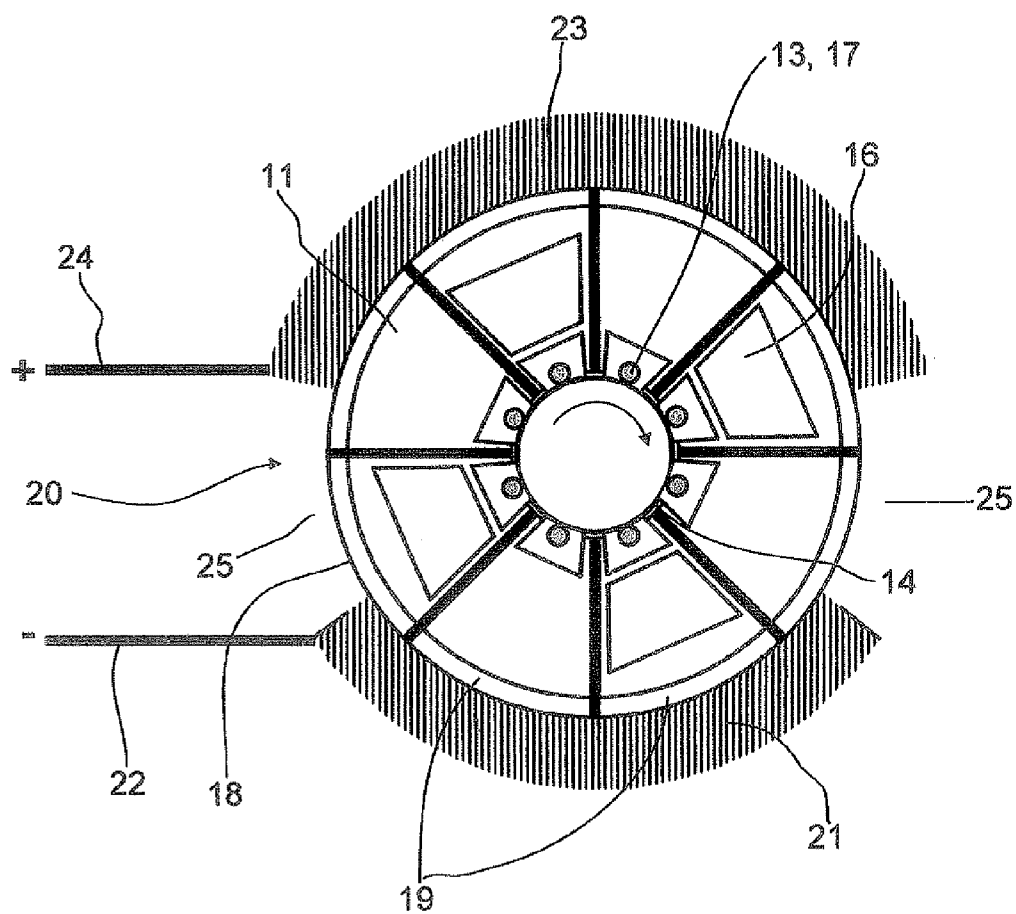

FIG.6



ELECTROPLATING DEVICE AND METHOD

[0001] The invention relates to a device for the electrolytic coating of at least one electrically conductive substrate or a structured or full-surface electrically conductive surface on a nonconductive substrate, which comprises at least one bath, one anode and one cathode, the bath containing at least one electrolyte solution containing a metal salt, from which metal ions are deposited on electrically conductive surfaces of the substrate to form a metal layer.

[0002] The invention furthermore relates to a method for the electrolytic coating of at least one substrate, which is carried out in a device designed according to the invention.

[0003] Electrolytic coating methods are used, for example, in order to coat electrically conductive substrates or structured or full-surface electrically conductive surfaces on a nonconductive substrate. For example, these methods can produce conductor tracks on printed circuit boards, RFID antennas, flat cables, thin metal foils, conductor tracks on solar cells, and can electrolytically coat other products such as two- or three-dimensional objects, for example shaped plastic parts.

[0004] DE-B 103 42 512 discloses a device and a method for the electrolytic treatment of electrically conductive structures electrically insulated from one another on surfaces of a strip-shaped object to be treated. Here, the object to be treated is transported on a conveyor belt and continuously in a transport direction, the object to be treated being contacted with a contacting electrode arranged outside an electrolysis region so that a negative voltage is applied to the electrically conductive structures. In the electrolysis region, metal ions from the treatment liquid then deposit on the electrically conductive structures to form a metal layer. Since metal is deposited on the electrically conductive structures only so long as they are contacted by the contact electrode, it is only possible to coat structures which are so largely dimensioned that the electrically conductive structure to be coated lies in the electrolysis region while being simultaneously contacted outside the electrolysis region.

[0005] A galvanizing apparatus in which the contacting unit is arranged in the electrolyte bath is disclosed, for example, in DE-A 102 34 705. The galvanizing apparatus described here is suitable for coating structures arranged on a strip-shaped support, which are already conductively formed. The contacting is in this case carried out via rolls which are in contact with the conductively formed structures. Since the rolls lie in the electrolyte bath, metal from the electrolyte bath likewise deposits on them. In order to be able to remove the metal again, the rolls are constructed from individual segments which are cathodically connected so long as they are in contact with the structures to be coated, and anodically connected when there is no contact between the rolls and the electrically conductive structure. A disadvantage of this arrangement, however, is that a voltage is applied only for a short time on structures which are short as seen in the transport direction, while a voltage is applied over a substantially longer period of time on structures which are long, likewise as seen in the transport direction. The layer which is deposited on long structures is therefore substantially larger than the layer which is deposited on short structures.

[0006] A disadvantage of the methods known from the prior art is that they cannot be used to coat structures which are very short—especially as seen in the transport direction of

the substrate. Another disadvantage is that many rolls connected in series are required in order to produce sufficiently long contact times, so that a very long device is needed.

[0007] It is an object of the invention to provide a device which ensures a sufficiently long contact time even for short structures, so that even short structures can be provided with a sufficiently thick and homogeneous metal layer. The device is furthermore intended to require less space.

[0008] The object is achieved by a device for the electrolytic coating of at least one electrically conductive substrate or a structured or full-surface electrically conductive surface on a nonconductive substrate, which comprises at least one bath, one anode and one cathode, the bath containing an electrolyte solution containing at least one metal salt, from which metal ions are deposited on electrically conductive surfaces of the substrate to form a metal layer while the cathode is brought in contact with the substrate's surface to be coated and the substrate is transported through the bath, wherein the cathode comprises at least two disks mounted on a respective shaft so that they can rotate, the disks engaging in one another.

[0009] Compared to the electrolytic coating devices which are known from the prior art, the device according to the invention with inter-engaging disks as the cathode makes it possible even for substrates with short electrically conductive structures, especially as seen in the transport direction of the substrate, to be provided with a sufficiently thick and homogeneous coating. This is made possible by the fact that a smaller spacing of the contact points of the disks with the electrically conductive structures can be produced by the inter-engaging disks than is the case with rolls arranged in series.

[0010] The disks are configured with a cross section matched to the respective substrate. The disks preferably have a circular cross section. The shafts may have any cross section. The shafts are preferably designed cylindrically.

[0011] In order to be able to coat structures which are wider than two adjacent disks, a plurality of disks are arranged next to one another on each shaft as a function of the width of the substrate. A sufficient distance is respectively provided between the individual disks, into which the disks of the subsequent shaft can engage. In a preferred embodiment, the distance between two disks on a shaft corresponds at least to the width of a disk. This makes it possible for a disk of a further shaft to engage into the distance between two disks on a shaft.

[0012] So that it is also possible to coat regions of the electrically conductive structure on which the cathode configured as disks or disk sections bears for contacting, at least four shafts with disks may be arranged offset pairwise in series. The arrangement is preferably such that the second shaft pair, arranged offset with respect to the first shaft pair, contacts the electrically conductive structure in the region on which the metal was deposited when contacting with the first shaft pair. In order to achieve a larger thickness of the coating, preferably more than two shaft pairs are connected in series. The engagement distances may furthermore be varied as desired. It is also possible to vary the spacings of the individual shaft pairs as desired.

[0013] The number of disks arranged next to one another on the at least one shaft depends on the width of the substrate. When the substrate to be coated is wider, commensurately more disks must be arranged next to one another. Here, care should be taken that a free gap respectively remains between

the disks, in which the metal can be deposited on the electrically conductive substrate, or the structured or full-surface electrically conductive surface of the substrate, and a disk of the shaft lying behind can engage.

[0014] The size of the disks which are used as the cathode depends on the size of the structures which are to be electrolytically coated. For example, structures whose length as seen in the transport direction is greater than or equal to the spacing, with which the disks offset in series touch the substrate, will be coated sufficiently when their width and position on the substrate are such that they are also touched by the successively offset rolls. In order to coat electrically conductive structures which are as small as possible, narrow disks with a small diameter are therefore used. An advantage of narrow disks with small mutual spacings is that the contacting probability of extremely small structures is thereby greater than with a smaller number of wide disks. Since the contact area of the disk hinders the deposition by covering the structures directly under the disk, it is advantageous to minimize this covering effect by narrow disks. At the same time, the electrolyte throughput over the surface to be coated is more uniform owing to a multiplicity of smaller surface accesses than with few surface accesses, as there are with a small number of wide disks.

[0015] The least possible disk width, and the smallest possible diameter with which the disks can be made, depend on the one hand on the available fabrication method and, on the other hand, on the disk being mechanically stable during operation i.e. the disk does not warp or bend during operation.

[0016] The distance between two inter-engaging disks depends on whether the disks have the same or different polarities. With the same polarity it is possible for the inter-engaging disks to touch, for example, while with different polarities it is necessary to provide a distance between the disks in order to avoid a short circuit. Furthermore, it is also necessary to ensure a sufficient flow of the electrolyte solution through the intermediate spaces between the disks and the space bounded by the substrate's surface to be coated.

[0017] In a preferred embodiment, the disks are supplied with voltage via the shaft. To this end, for example, it is possible to connect the shaft to a voltage source outside the bath. This connection is generally carried out via a slipping. Nevertheless, any other connection with which a voltage transmission is transmitted from a stationary voltage source to a rotating element is possible. Besides the voltage supply via the shaft, it is also possible to supply the contact disks with current via their outer circumference. For example, sliding contacts such as brushes may lie in contact with the contact disks on the other side from the substrate.

[0018] In order to supply the disks with current via the shafts, for example, the shafts and the disks in a preferred exemplary embodiment are made at least partly of an electrically conductive material. Besides this, however, it is also possible to make the shafts from an electrically insulating material and for the current supply to the individual disks to be produced for example through electrical conductors, for example wires. In this case, the individual wires are then respectively connected to the contact disks so that the contact disks are supplied with voltage.

[0019] When the disks are made of an electrically conductive material only on their outer circumference, then it is necessary to provide an electrical conductor which connects the shaft to the outer circumference of the disk. To this end, for example, an electrical conductor may be accommodated

inside the disk. The current supply may also be produced via a fastening means, for example a screw, by which the disk is fastened on the shaft.

[0020] In order to produce a uniform electrolyte supply, in a preferred embodiment apertures are formed in the disks. The electrolyte solution can be transported to the substrate through the apertures. At the same time, the mixing of the electrolyte is improved owing to the rotation of the disks compared to an embodiment with closed disks. Electrolyte solution can also be delivered to the substrate more rapidly through the perforated disks than would be possible if the electrolyte solution could flow only through the gaps between the individual disks.

[0021] Instead of apertures in solid disks, it is also possible to provide disks in which a ring is fastened on the shaft by spokes. In order to permit electrolytic coating, it is necessary for the ring to be made of an electrically conductive material on its outer circumference. In a preferred embodiment, the entire ring is made of an electrically conductive material. The spokes, by which the ring is fastened on the shaft, may for example be made of an electrically conductive material or an electrically insulating material. When the spokes are made of an electrically conductive material, it is preferable for the voltage supply of the ring to take place via the shaft and the spokes. When the spokes are made of an electrically insulating material, for example, it is possible to provide a spoke which is electrically conductive so that the voltage can be transmitted from the shaft to the ring. Besides this, with spokes made of an electrically insulating material, it is also possible to connect the ring to the current-carrying shaft via a current conductor, for example a cable. With electrically insulating spokes, it is also possible to apply the voltage directly to the ring surface. To this end, for example, the ring surface is contacted with a sliding contact such as a brush.

[0022] In order to be able to carry out electrolytic coating of the substrate with metal ions from the electrolyte solution to form a metal layer, the disks are respectively connected cathodically in the aforementioned exemplary embodiments. Owing to the cathodic connection of the disks, metal also deposits on them. It is therefore necessary to connect the disks anodically in order to remove the deposited metal, i.e. demetallize them. This may, for example, be done in production pauses. In order to be able to carry out demetallization during operation, in a preferred embodiment the disks can be raised from the substrate and lowered onto it. The disks which are lowered onto the substrate may in this case be connected cathodically, while the disks which are raised from the substrate are connected anodically. Through the cathodically connected disks which are lowered onto the substrate, the electrically conductive structures on the substrate are cathodically contacted and therefore coated. At the same time, by the anodic connection of the disks which do not touch the substrate, the metal previously deposited on them is removed again.

[0023] It is possible, for example, respectively to keep a shaft with its disks lowered onto the substrate and alternately have a shaft with its disks raised from the substrate. Preferably, however, at least two successive shafts with their inter-engaging disks are respectively lowered onto the substrate, in order to avoid failing to coat electrically conductive substrates which are passed through a gap between two disks without cathodic contacting. As soon as two successive shafts with their inter-engaging disks touch the substrate, these substrates which are passed through a gap between two disks are

contacted by the subsequent disk which engages in this gap. Coating of these electrically conductive structures is therefore also ensured.

[0024] In a preferred embodiment the disks have individual sections, electrically insulated from one another, distributed over the circumference. The sections electrically insulated from one another can preferably be connected both cathodically and anodically. It is thereby possible for a section which is in contact with the substrate to be connected cathodically and, as soon as it is no longer in contact with the substrate, connected anodically. In this way, metal deposited on the section during the cathodic connection is removed again during the anodic connection. The voltage supply of the individual segments generally takes place via the shaft. When a plurality of disks are arranged next to one another on a shaft, they are preferably aligned so that the individual sections electrically insulated from one another are arranged flush in the axial direction. It is in this way possible for individual sections electrically insulated from one another, which lie flush in the axial direction, to be respectively contacted with a common line. Furthermore, it is likewise possible to construct the shaft in individual segments, which are electrically insulated from one another, correspondingly as the segments of the individual disks. In this case, the individual segments can then be used for the current supply to the disks. The shaft is preferably contacted outside the bath. Contacting is possible, for example, through poling reversal disks or contact disks, which are brought in contact with the shaft. When individual lines which contact the disks' individual sections electrically insulated from one another are respectively provided, these lines may be positioned either inside or on the outer circumference of the shaft.

[0025] Other cleaning variants are also possible besides removing the metal deposited on the shaft and the disks by reversing the polarity of the shafts, for example chemical or mechanical cleaning.

[0026] The material from which the electrically conductive parts of the disks are made is preferably an electrically conductive material which does not pass into the electrolyte solution during operation of the device. Suitable materials are for example metals, graphite, conductive polymers such as polythiophenes or metal/plastic composite materials. Stainless steel and/or titanium are preferred materials.

[0027] So that the disks do not dissolve when they are connected anodically in order to remove the metal deposited on them, the material which is conventional for insoluble anodes and is known to the person skilled in the art is preferably used for the disks and the shafts. For example, titanium coated with a conductive mixture of metal oxides is such a suitable material.

[0028] In a further embodiment, the electrolytic coating device furthermore comprises a device with which the substrate can be rotated. By rotation, electrically conductive structures which are initially wide and short as seen in the transport direction of the substrate can be aligned so that they are narrow and long—as seen in the transport direction—after rotation. The rotation compensates for different coating times which are due to the fact that coating of the electrically conductive structure already takes place upon the first contact with the cathodically connected disk.

[0029] After rotation, the substrate passes either through the device for a second time or through a second corresponding device. The angle through which the substrate is rotated preferably lies in the range of from 10° to 170°, more prefer-

ably in the range of from 50° to 140°, in particular in the range of from 80° to 100°, and more particularly preferably the angle through which the substrate is rotated is essentially 90°. Essentially 90° means that the angle through which the substrate is rotated does not differ by more than 5° from 90°. The device for rotating the substrate may be arranged inside or outside the bath. In order to coat the same side of the substrate again, for example so as to achieve a greater layer thickness of the metal layer, the rotation axis is aligned perpendicularly to the surface to be coated.

[0030] When another surface of the substrate is intended to be coated, the rotation axis is arranged so that after rotation the substrate is positioned in such a way that the surfaced intended to be coated next points in the direction of the cathode.

[0031] The layer thickness of the metal layer deposited on the electrically conductive structure by the method according to the invention depends on the contact time, which is given by the speed of the substrate through the device and the number of shafts positioned in series with inter-engaging disks arranged on them, as well as the current strength with which the device is operated. A longer contact time may be achieved, for example, by connecting a plurality of devices according to the invention in series in at least one bath.

[0032] In one embodiment, a plurality of devices according to the invention are connected in series respectively in individual baths. It is therefore possible to hold a different electrolyte solution in each bath, so as to deposit different metals successively on the electrically conductive structures. This is advantageous, for example, in decorative applications or for the production of gold contacts. Here again, the respective layer thicknesses can be adjusted by selecting the throughput speed and the number of devices with the same electrolyte solution.

[0033] In order to allow simultaneous coating of the upper and lower sides of the substrate, in one embodiment of the invention two shafts with disks mounted on them are respectively arranged so that the substrate to be coated can be moved through between them. According to the invention, two shafts with inter-engaging disks held on them are respectively provided both on the upper side and the lower side of the substrate. In general, the structure is then such that a plane in which the substrate is guided serves as a mirror plane. When the intention is to coat foils whose length exceeds the length of the bath—so-called endless foils which are first unwound from a roll, guided through the electrolytic coating device and then wound up again—they may for example also be guided through the bath in a zigzag shape or in the form of a meander around a plurality of electrolytic coating devices according to the invention, which for example may then also be arranged above one another or next to one another.

[0034] With the device according to the invention and the method according to the invention, it is furthermore possible to coat through-holes contained in the substrate, for instance bores or slots, or even indentations such as blind holes. In the case of through-holes of shallow depth, the coating is carried out in that the metal layers deposited on the upper side and the lower side grow together in the hole. In holes which are too deep for the metal layers to grow together, a conductive hole wall is at least partially provided which is coated by the method according to the invention. In this way, it is then also possible to coat the entire wall of a hole. If not all of the hole wall is electrically conductive, here again the entire hole wall is coated by the metal layers growing together.

[0035] When only one side of the substrate is intended to be coated, the substrate may either rest on the inter-engaging disks, in which case the lower side of the substrate is coated, or be guided along the lower side of the disks, in which case the upper side of the substrate is coated. When the substrate rests on the disks, the disks may be simultaneously used for transporting the substrate. Sufficient contact of the inter-engaging disks with the substrate is achieved by pressing the substrate onto the inter-engaging disks, preferably by a pressure device. Pressure rolls or belts, which are guided around shafts and pressed against the substrate, are for example suitable as a pressure device.

[0036] When the substrate is guided along the lower side of the disks, it is necessary to provide a transport device by which the substrate is brought in contact with the disks. Such a transport device is for example a belt or rolls, on which the substrate runs. The substrate may then be pressed with a predetermined application force either against the transport device by means of the electrolytic coating device, or against the electrolytic coating device by means of the transport device.

[0037] When the substrate is coated simultaneously on its upper side and its lower side, the inter-engaging disks connected as the cathode, which contact the substrate, may be used simultaneously for transporting the substrate through the bath.

[0038] Either individual shafts or all the shafts may be driven in order to transport the substrate. They are preferably driven outside the bath. When a transport device independent of the cathodically connected disks is provided, the shafts and the disks fitted on them may be set in rotation by the substrate so that the circumferential speed of the disks corresponds to the speed at which the substrate is transported.

[0039] So that a uniform circumferential speed of all the shafts or disks is achieved, it is preferable for all the shafts to be driven via a common drive unit. The drive unit is preferably an electric motor. The shafts are preferably connected to the drive unit via a chain or belt transmission. It is nevertheless also possible to provide the shafts respectively with gearwheels which engage in one another and via which the shafts are driven. Besides the possibilities described here, it is also possible to use any other suitable drive known to the person skilled in the art for driving the shafts.

[0040] On the one hand, with different poling of shafts, disks or the disks' sections insulated from one another, the anodically connected shafts, disks or the disks' sections insulated from one another may be used as anodes, and on the other hand it is possible to provide additional anodes in the bath. When only cathodically connected shafts and disks are provided, it is necessary to arrange additional anodes in the bath. The anodes are then preferably arranged as close as possible to the structure to be coated. For example, the anodes may respectively be arranged before the first shaft and behind the last shaft with inter-engaging disks. When the substrate is coated only on one side, it is for example also possible to arrange the cathode on the side of the substrate where the electrolytic coating is intended to take place and the anode—without it touching the substrate—on the other side of the substrate. On the one hand any material known to the person skilled in the art for insoluble anodes is suitable as a material for the anodes. Stainless steel, graphite, platinum, titanium or metal/plastic composite materials, for example, are preferred here. On the other hand, soluble anodes may also be provided. These then preferably contain the metal which is electrolyti-

cally deposited on the electrically conductive structures. The anodes may then assume any desired shape known to the person skilled in the art. For example, it is possible to use flat rods which are at a minimal distance from the substrate surface during operation of the device as the anodes. It is also possible to use flat metal or elastic wires, for example spiral wires, as the anodes.

[0041] In order to coat a flexible circuit support, which is preferably in the form of a strip, this is unwound from a roll lying before the bath and wound onto a new roll after passing through the bath.

[0042] With the device according to the invention, it is possible to coat all electrically conductive surfaces irrespective of whether the intention is to coat mutually insulated electrically conductive structures on a nonconductive substrate or a full surface. The device is preferably used for coating electrically conductive structures on an electrically nonconductive support, for example reinforced or unreinforced polymers such as those conventionally used for circuit boards, ceramic materials, glass, silicon, textiles etc. The electrolytically coated electrically conductive structures produced in this way are, for example, conductor tracks. The electrically conductive structures to be coated may, for example, be made of an electrically conductive material printed on the circuit board. The electrically conductive structure preferably either contains particles of any geometry made of an electrically conductive material in a suitable matrix, or consists essentially of the electrically conductive material. Suitable electrically conductive materials are, for example, carbon or graphite, metals, preferably aluminum, iron, gold, copper, nickel, silver and/or alloys or metal mixtures which contain at least one of these metals, electrically conductive metal complexes, conductive organic compounds or conductive polymers.

[0043] A pretreatment may possibly be necessary first, in order to make the structures electrically conductive. This may, for example, involve a chemical or mechanical pretreatment such as suitable cleaning. In this way, for example, the oxide layer which is disruptive for electrolytic coating is previously removed from metals. The electrically conductive structures to be coated may, however, also be applied on the circuit boards by any other method known to the person skilled in the art.

[0044] Such circuit boards are, for example, installed in products such as computers, telephones, televisions, electrical parts for automobiles, keyboards, radios, video, CD, CD-ROM and DVD players, game consoles, measuring and control equipment, sensors, electrical kitchen equipment, electronic toys etc.

[0045] Electrically conductive structures on flexible circuit supports may also be coated with the device according to the invention. Such flexible circuit supports are, for example, polymer films such as polyimide films, PET films or polyolefin films, on which electrically conductive structures are printed. The device according to the invention and the method according to the invention are furthermore suitable for the production of RFID antennas, transponder antennas or other forms of antenna, chip card modules, flat cables, seat heaters, foil conductors, conductor tracks in solar cells or in LCD/plasma display screens or for the production of electrolytically coated products in any form, for example thin metal foils, polymer supports metal-clad on one or two sides with a defined layer thickness, 3D-molded interconnect devices or else for the production of decorative or functional surfaces on

products, which are used for example for shielding electromagnetic radiation, for thermal conduction or as packaging. It is furthermore possible to produce contact sites or contact pads or interconnections on an integrated electronic component.

[0046] After leaving the electrolytic coating device, the substrate may be further processed according to all steps known to the person skilled in the art. For example, remaining electrolyte residues may be removed from the substrate by washing and/or the substrate may be dried.

[0047] The device according to the invention for the electrolytic coating of electrically conductive substrates or electrically conductive structures on electrically nonconductive substrates may, according to requirements, be equipped with any auxiliary device known to the person skilled in the art. Such auxiliary devices are, for example, pumps, filters, supply instruments for chemicals, winding and unwinding instruments etc.

[0048] All methods of treating the electrolyte solution known to the person skilled in the art may be used in order to shorten the maintenance intervals. Such treatment methods, for example, are also systems in which the electrolyte solution self-regenerates.

[0049] The device according to the invention may also be operated, for example, in the pulse method known from Werner Jillek, Gustl Keller, Handbuch der Leiterplattentechnik [handbook of printed circuit technology], Eugen G. Leuze Verlag, 2003, volume 4, pages 192, 260, 349, 351, 352, 359.

[0050] The electrolytic coating device can be used for any conventional metal coating. The composition of the electrolyte solution, which is used for the coating, in this case depends on the metal with which the electrically conductive structures on the substrate are intended to be coated. Conventional metals which are deposited on electrically conductive surfaces by electrolytic coating are, for example, gold, nickel, palladium, platinum, silver, tin, copper or chromium.

[0051] Suitable electrolyte solutions, which can be used for the electrolytic coating of electrically conductive structures, are known to the person skilled in the art for example from Werner Jillek, Gustl Keller, Handbuch der Leiterplattentechnik [handbook of printed circuit technology], Eugen G. Leuze Verlag, 2003, volume 4, pages 332 to 352.

[0052] The advantage of the device according to the invention and the method according to the invention is that the inter-engaging disks provide a greater contact area and therefore a longer contact time per unit area than is the case with rolls such as those known from the prior art. It is therefore possible to produce shorter paths with greater metal buildup and more homogeneous layer thicknesses. The installations can also be made shorter, which allows a greater throughput with lower operating costs. Another essential advantage is that now even very short structures, for example those desired in the production of circuit boards, can be produced more rapidly, with greater control and above all more reproducibly and with homogeneous layer thicknesses than is possible with the roll systems known from the prior art.

[0053] The invention will be explained in more detail below with the aid of the drawings. The figures respectively show only one possible embodiment by way of example. Other than in the embodiments mentioned, the invention may naturally also be implemented in further embodiments or in a combination of these embodiments.

[0054] FIG. 1 shows a plan view of a device designed according to the invention,

[0055] FIG. 2 shows a side view of a device designed according to the invention,

[0056] FIG. 3 shows a side view of a device designed according to the invention in a second embodiment,

[0057] FIG. 4 shows a shaft with a single disk mounted on it,

[0058] FIG. 5 shows a disk designed according to the invention with individual sections electrically insulated from one another distributed over the circumference,

[0059] FIG. 6 shows a contact disk for the current supply.

[0060] FIG. 1 represents a plan view of a device designed according to the invention. A number of first disks 2 are arranged on a first shaft 1. The disks 2 are respectively mounted on the shaft 1 with a spacing 3. The spacing 3 is selected so that disks 4 which are fastened on a second shaft 5 can engage in it. The spacing 6 of the second disks 4 is selected so that a first disk 2 can respectively engage between two second disks 4.

[0061] In the embodiment represented in FIG. 1, the first disks 2 which are mounted on the first shaft 1 and the second disks 4 which are mounted on the second shaft 5 respectively have the same width. It is nevertheless also possible to provide disks with different widths. In this case, disks of equal width may respectively be provided on one shaft, while disks with a width which differs from the width of the disks on the first shaft are provided on the second shaft, or disks with different widths are mounted on one shaft. When disks with different widths are mounted on one shaft, it is necessary for the distances between two disks on the second shaft, which engage between two disks on the first shaft, to be selected accordingly so that the differently wide disks can engage in the spacings.

[0062] Preferably, at least two shaft pairs with inter-engaging disks may also be connected in series. The shaft pairs may then be aligned mutually offset. It is also possible for the disks of the front shaft of the rear pair to engage in the spacings between the disks of the rear shaft of the front pair.

[0063] The distance 3 between two first disks 2 is at least as great as the width of a second disk 4. The spacing 6 of the second disks 4 is likewise at least as great as the width of a first disk 2. The distance 3, 6 between two disks 2, 4 is preferably greater than the width of the disks 2, 4 respectively engaging in this spacing, so that electrolyte solution can flow through this spacing in the direction of the substrate to be coated. The engagement depth 7, with which the second disks 4 engage in the first disks 2, depends on the spacing with which the first disks 2 and the second disks 4 are intended to contact the substrate. For instance, it is possible for the disks 2, 4 to engage with one another precisely in the edge region, or for the first disks 2 to engage between the second disks 4 so widely that the first disks 2 just touch the second shaft 5. With an equal diameter of the first disks 2 and the second disks 4, in this case the second disks 4 also touch the first shaft 1. It is, however, not necessary for the first disks 2 and the second disks 4 to be configured with the same diameter. It is equally well possible for the diameters of the first disks 2 and the second disks 4 to be different.

[0064] FIG. 2 shows a side view of a device designed according to the invention.

[0065] FIG. 2 shows the way in which the first disks 2 engage in the second disks 4. The contact of the disks 2, 4 with the electrically conductive structures 30 to be coated on the substrate 31 takes place with the spacing of the axial mid-points of the first shaft 1 and the second shaft 5. The closer

together the axial mid-points of the first shaft **1** and the second shaft **5** lie, the closer together the contact points of the first disks **2** and the second disks **4** with the substrate lie. The spacing with which the first disks **2** and the second disks **4** touch the substrate is denoted by reference numeral **8**.

[0066] In the embodiment represented here, the substrate **31** is transported through the bath of electrolyte solution by means of a transport device **32**. The transport device **32** in the embodiment represented here comprises an endless belt **33** which runs around two shafts **34, 35**. The distance between the belt **33** and the disks **2, 4** is selected so that the substrate **31** with the electrically conductive structures **30** is pressed onto the disks **2, 4** with a defined application force. The electrically conductive structures **30** may optionally be pressed onto the disks **2, 4** by mounting the transport device **32** fixed and, for example, pressing the disks **2, 4** with a predetermined application force onto the substrate **31** with the electrically conductive structures **30**, to which end the shafts **1, 5** of the disks **2, 4** may be resiliently mounted. Alternatively, the axles **1, 5** of the disks **2, 4** may be mounted fixed and a predetermined application pressure may be exerted on the substrate **31** by the transport device **32**. To this end, the shafts **34, 35** of the transport device **32** are preferably mounted resiliently. Instead of a transport device **32** as represented in FIG. 2, a plurality of individual shafts arranged next to one another may also be used as a transport device. Instead of the transport device **32**, it is also possible to provide a second device according to the invention which comprises at least two axles with inter-engaging disks arranged on them.

[0067] In order to ensure the transport, it is possible to drive either the axles **1, 5** on which the disks **2, 4** are fastened or the shafts **34, 35** with the endless belt **33**. It is also possible to drive both the axles **1, 5** with the disks **2, 4** arranged on them and the shafts **34, 35**. The drive of the shafts **1, 5** and **34, 35** is preferably arranged outside the bath. On the one hand each shaft **1, 5, 34, 35** may be driven individually, although preferably the shafts **1** and **5** are driven by a first drive and the shafts **34** and **35** are driven by a second drive, or all the shafts **1, 5, 34, 35** are driven by a common drive. The individual shafts **1, 5** and/or **34, 35**, for example, connected together via gearwheels or chain or belt transmissions.

[0068] So that a current can flow in the electrolyte solution and electrolytic coating of the electrically conductive structures **30** is therefore made possible, anodes **36** are furthermore provided in the bath. The anodes **36** may for example, as represented here, be configured in the form of flat rods. The anodes **36** are preferably arranged in the vicinity of the electrically conductive structure **30** to be coated. In this case, care should be taken that the anodes **36** do not touch the electrically conductive structure **30** since otherwise the metal already deposited on it would be removed again. Besides the embodiment of the anodes **36** in the form of flat rods, the anodes **36** may also be configured as flat metal or as elastic wires, for example spiral wires. It is also possible to use other anode forms known to the person skilled in the art. The anodes may be both insoluble and soluble.

[0069] The material for insoluble anodes **36** is known to the person skilled in the art. For soluble anodes **36**, it is preferable to use the metal which is deposited on the electrically conductive structures **30**.

[0070] FIG. 3 shows a side view of a device designed according to the invention in a further embodiment.

[0071] In contrast to the embodiment represented in FIG. 2, with the device shown in FIG. 3 it is possible to coat electri-

cally conductive structures **30** simultaneously on the upper side and the lower side of the substrate **31**. It is also possible to electrolytically coat holes **37** in the substrate and thus obtain an electrically conductive connection between the electrically conductive structure **30** on the upper side and the electrically conductive structure **30** on the lower side of the substrate **31**. To this end, respectively, a device which comprises at least two shafts **1, 5** with inter-engaging disks **2, 4** arranged on them is arranged on the upper side of the substrate **31**, and a device which comprises at least two shafts **1, 5** with inter-engaging disks **2, 4** arranged on them is arranged on the lower side of the substrate **31**. The substrate is guided through between the devices. The substrate is preferably transported by the disks **2, 4**, which contact the electrically conductive structures **30**. To this end either all the shafts **1, 5** on which the disks **2, 4** are arranged are driven, or only individual shafts **1, 5** are driven while the other shafts are mounted so that they are set in rotation by the substrate **31** when the substrate is contacted by the disks **2, 4** on these shafts.

[0072] FIG. 4 shows a shaft designed according to the invention with a disk mounted on it.

[0073] A disk **10** as represented in FIG. 4 comprises individual sections **11**. The sections **11** are respectively insulated electrically from one another by an insulation **12**. This, for example, makes it possible for sections **11** lying next to one another to be connected differently. For example, one section **11** may be connected cathodically while the adjacent section **11** is connected anodically. The advantage of this embodiment is that metal which deposits on the section **11** while it is connected cathodically is removed again from this section **11** when it is connected anodically. This removal of the metal deposited on the individual sections **11** is possible during operation of the coating device. So that sections **11** lying next to one another can be connected differently, either its own current supply **13** is provided separately for each section **11** on each individual disk **10** or, since the neighboring sections **11** of disks **10** lying next to one another can respectively be connected in the same way, a continuous current supply **13** is provided with which the respectively adjacent sections **11** of the adjacent disks **10** are contacted. An insulated cable which is fastened on the outer circumference of the rolls, for example, is suitable as the current supply **13**. Instead of on the outer circumference of the shaft **14**, the insulated cable may also extend inside the shaft **14**. To this end, for example, it is necessary for the shaft **14** to be designed as a hollow shaft.

[0074] Besides the current supply via an insulated cable, the current supply may also take place directly via the shaft. To this end, for disks **10** which are constructed in individual sections **11** electrically insulated from one another, the shaft **14** is likewise constructed in individual sections electrically insulated from one another. The current supply may then respectively take place via the individual electrically conductive sections of the shaft **14**. To this end, the sections **11** of the disk **10** are respectively connected to an electrically conductive section of the shaft **14**.

[0075] When the current supply to the individual sections **11** of the disk **10** respectively takes place via a current supply **13** in the form of an insulated cable, the individual sections **11** are for example respectively connected to the current supply **13** by cable connections **15**. The cable connection **15** may—as represented in FIG. 4—be arranged on the outside of the disk **10**, although it is also possible to provide the cable connections **15** on the end of the individual segments **11**

facing the shaft 14, in order avoid any lateral broadening of the disks 10. This may, for example, be done using a pin which is inserted into an insulated cable serving as the current supply 13.

[0076] FIG. 5 shows a side view of a disk according to FIG. 4.

[0077] In the embodiment represented here, the current supply of the individual segments 11 of the disk 10 takes place via individual insulated cables which are arranged on the outer circumference of the shaft 14. When a plurality of disks 10 are arranged next to one another on the same shaft 14, openings through which the cables 17 can be guided are preferably formed in the individual segments 11 on the side facing the shaft 14. The individual segments 11 are connected to the cable 14 via contact connections 15.

[0078] In order to improve the electrolyte supply to the substrate to be coated, recesses 16 may be formed in the segments 11. In this case, the electrolyte solution can flow through the recesses 16. The recesses 16 may respectively be formed only in individual segments 11 of the disk 10 or in all segments 11 of the disk 10. Furthermore, instead of the recesses 16 in the disk 10, it is also possible to configure the disk 10 in the form of a wheel in which an electrically conductive ring with individual spokes is fitted on the shaft 14. In order to permit electrolytic coating of a substrate, it is necessary for the disk 10 to be electrically conductive on its outer circumference. To this end, for example, it is possible to provide the disk 10 with an annular contacting region 18 which is provided on the outer circumference of the disk 10. The conventional material known to the person skilled in the art, which is currently used for insoluble anodes, is for example suitable as a material for the annular contacting region 18. This may, for example, be titanium coated with a conductive mixture of metal oxides.

[0079] When only the annular contacting region 18 is configured to be electrically conductive, the individual segments 11 may be made of an electrically insulating material in the region between the annular contacting region 18 and the shaft 14. In this case, it is merely necessary to provide a current conductor either through the electrically conductive material or on the surface of the individual segments, by which the voltage from the current supply 13, which in the embodiment represented here is configured as cables 17 that rest on the outer circumference of the shaft, can be carried to the annular contacting region 18. When only the annular contacting region 18 is configured to be electrically conductive, in order to permit anodic and cathodic connection alternately it is sufficient for the insulation 12 to be provided respectively between individual segments 19 of the annular contacting region 18. Directly by means of this, the segments 19 of the annular contacting region 18 are electrically insulated from one another sufficiently in order to avoid a short circuit between an anodically connected segment 19 and a cathodically connected segment 19.

[0080] FIG. 6 shows an embodiment of a current supply of a device designed according to the invention.

[0081] The current supply to a shaft 14 with disks 10 arranged on it may, for example, take place via a further disk 20 arranged outside the bath of electrolyte solution. The further disk 20 is, for example, constructed like a disk 10 with which the substrate to be coated is contacted. To this end, the further disk 20 likewise comprises an annular contacting region 18 which is divided into individual segments 19. Instead of an annular contacting region 18, it is also possible

for the individual segments 11 of the further disk 20 to be respectively made entirely of an electrically conductive material. To reduce weight, it is possible to provide recesses 16 in the individual segments 11 for the further disk 20 as well. The recesses 16 may be formed in each segment 11 or only in individual segments 11. The individual segments 19 of the annular contacting region 18 are electrically connected to the current supply 13 which, in the embodiment represented in FIG. 6, is likewise designed in the form of cables 17 that are arranged on the outer circumference of the shaft 14.

[0082] When the entire sections 11 are made of an electrically conductive material, it is preferable for the further disk 20 to be provided with an electrical insulation on its end faces so that there is an electrically conductive surface only on the outer circumference. This can prevent injury from occurring as a result of inadvertently touching the disk 20.

[0083] In order to supply the annular contacting region 18 with voltage, in the embodiment represented here a cathodic sliding contact 21 which is connected to a cathodic current supply 22, and an anodic sliding contact 23 which is connected to an anodic current supply 24 are provided. Any sliding contact known to the person skilled in the art may be used as a cathodic sliding contact 21 and as an anodic sliding contact 23.

[0084] When the shaft is constructed from individual electrically conductive segments which are separated from one another by an insulation, the current supply may also take place directly to the shaft via sliding contacts. A further disk 20 is not necessary in this case.

[0085] In order to avoid a short circuit, sufficiently large distances 25 should respectively be provided between the anodic sliding contact 23 and the cathodic sliding contact 21. The distance 25 between the anodic sliding contact 23 and the cathodic sliding contact 21 must be greater than the width of a segment 19. If the width of a section 25 is less than or equal to the width of a segment 19, a short circuit will take place each time the segment 19 simultaneously touches the cathodic sliding contact 21 and the anodic sliding contact 23.

[0086] So that all the metal which deposits on the disks 10 while they are connected cathodically can be removed from them again, the anodically contact region is preferably larger than the cathodic contact region. This means that preferably more segments are connected anodically than are connected cathodically. The maximum number of cathodically connected segments 19 corresponds to the number of anodically connected segments 19.

[0087] In the case of cables 17 extending radially on the shaft 14, with the embodiment represented in FIG. 5 the substrate to be coated should be guided along the lower side of the disks 10. If the substrate is to be guided along the upper side of the disks 10 so that the lower side of the substrate is coated, the cathodic sliding contact must be arranged on the upper side of the further disk 20 and the anodic sliding contact on the lower side of the further disk 20.

[0088] In order to be able to coat a substrate simultaneously on its upper side and its lower side, it is possible to arrange two electrolytic coating devices above one another or next to one another, the substrate being guided through between the devices so that it is contacted simultaneously on its upper side and its lower side by the disks 10.

[0089] So long as the segments with which cathodic contacting of the substrate takes place lie inside the electrolyte solution, the substrate can be guided along the individual devices at any desired angle. It is not necessary for the sub-

strate to be transported through the bath horizontally, i.e. parallel to the liquid surface. If the substrate to be coated is held firmly enough, for example, it is even possible for it to be guided perpendicularly to the liquid surface along the disks **10** for contacting.

LIST OF REFERENCES

[0090]	1 first shaft
[0091]	2 first disk
[0092]	3 spacing of the first disks
[0093]	4 second disk
[0094]	5 second shaft
[0095]	6 spacing of the second disks
[0096]	7 engagement depth
[0097]	8 spacing of the contact points
[0098]	10 disk
[0099]	11 section
[0100]	12 insulation
[0101]	13 current supply
[0102]	14 shaft
[0103]	15 cable connection
[0104]	16 recess
[0105]	17 cable
[0106]	18 annular contacting region
[0107]	19 segment
[0108]	20 further disk
[0109]	21 cathodic sliding contact
[0110]	22 cathodic current supply
[0111]	23 anodic sliding contact
[0112]	24 anodic current supply
[0113]	25 spacing
[0114]	30 electrically conductive structure
[0115]	31 substrate
[0116]	32 transport device
[0117]	33 endless belt
[0118]	34 shafts
[0119]	35 shafts
[0120]	36 anode
[0121]	37 hole in the substrate 31

1.-24. (canceled)

25. A device for the electrolytic coating an electrically conductive surface, the device comprising:

a bath of an electrolyte solution containing at least one metal salt;

an anode in contact with the bath; and

a cathode comprising at least two disks, each mounted on respective shafts, the disks being rotatable on the shafts and engaging one another, wherein while the electrically conductive surface is transported through the bath and the cathode is brought in contact with the electrically conductive surface, metal ions from the metal salt are deposited on the electrically conductive surface.

26. The device as claimed in claim **25**, wherein the cathode further comprises a plurality of disks, with several of the disks being arranged next to one another on each shaft.

27. The device as claimed in claim **26**, wherein the distance between adjacent disks on one of the shafts is at least to the width of one of the disks.

28. The device as claimed in claim **25**, wherein the shafts include conductors to supply the disks with voltage.

29. The device as claimed in claim **28**, wherein the shaft and the disks are made at least partly of an electrically conductive material which does not pass into the electrolyte solution during operation.

30. The device as claimed in claim **25**, wherein recesses are formed in the disks.

31. The device as claimed in claim **25**, wherein at least one disk comprises a ring which is fastened on the respective axle by spokes.

32. The device as claimed in claim **25**, wherein at least one disk includes a plurality of sections, electrically insulated from one another, distributed over the circumference.

33. The device as claimed in claim **32**, wherein the sections are adapted to be connected both cathodically and anodically.

34. The device as claimed in claim **32**, wherein the shafts are constructed from a plurality of electrically conductive segments which are respectively separated from one another by nonconductive segments, the electrically conductive segments being adapted to be connected both cathodically and anodically and the conductive segments of the shaft respectively contacting one of the sections of at least one of the disks.

35. The device as claimed in claim **25**, wherein the disks are adapted to be raised from the electrically conductive surface and lowered onto it.

36. The device as claimed in claim **25**, further comprising an apparatus adapted to rotate the electrically conductive surface, the apparatus being disposed either inside or outside the bath.

37. The device as claimed in claim **25**, further comprising a second cathode a cathode comprising at least two disks, each mounted on respective shafts, the disks being rotatable on the shafts and engaging one another, wherein the electrically conductive surface is passed between the two cathodes to deposit metal ions on both sides of the electrically conductive surface.

38. The device as claimed in claim **25**, wherein in order to coat flexible supports which are unwound from a first roll and wound onto a second roll, a plurality of devices, respectively having at least two shafts with inter-engaged disks arranged thereon, are arranged above one another or next to one another, the flexible support passing through the devices in a meandering fashion.

39. The device as claimed in claim **25**, wherein the electrically conductive surface comprises a substrate.

40. The device as claimed in claim **25**, wherein the electrically conductive surface comprises at least one of a structured or full-surface electrically conductive surface on a non-conductive substrate.

41. A method for the electrolytic coating of an electrically conductive surface, the method comprising:

transporting the electrically conductive surface through a bath of an electrolyte solution containing at least one metal salt;

placing an anode in contact with the bath;

placing a cathode in contact with the electrically conductive surface, wherein the cathode comprises at least two disks, each mounted on respective shafts, the disks engaging one another and rotating while at least one of the disks contacts the electrically conductive surface to deposit metal ions from the metal salt onto the electrically conductive surface.

42. The method as claimed in claim **41**, further comprising cathodically connecting disks which touch the electrically conductive surface and anodically connecting disks which are not in contact with the electrically conductive surface.

43. The method as claimed in claim **41**, further comprising cathodically connecting sections of the disks which are in contact with the electrically conductive surface and anodi-

cally connecting sections of the disks which are not in contact with the electrically conductive surface.

44. The method as claimed in claim **41**, further comprising supplying the disks with voltage via the shafts.

45. The method as claimed in claim **41**, further comprising connecting the shafts anodically for demetallization.

* * * * *