

(19) World Intellectual Property Organization
International Bureau



(43) International Publication Date
16 November 2006 (16.11.2006)

PCT

(10) International Publication Number
WO 2006/121949 A1

- (51) **International Patent Classification:**
G01R 33/36 (2006.01) G01R 33/345 (2006.01)
- (21) **International Application Number:**
PCT/US2006/017576
- (22) **International Filing Date:** 5 May 2006 (05.05.2006)
- (25) **Filing Language:** English
- (26) **Publication Language:** English
- (30) **Priority Data:**
60/678,759 6 May 2005 (06.05.2005) US
- (71) **Applicant (for all designated States except US):** **REGENTS OF THE UNIVERSITY OF MINNESOTA** [US/US]; 450 Mcnamara Alumni Center, 200 Oak Street Southeast, Minneapolis, MN 55455 (US).
- (72) **Inventor; and**
- (75) **Inventor/Applicant (for US only):** **VAUGHAN, J., Thomas** [US/US]; 504 South 5th Street, Stillwater, MN 55082 (US).
- (74) **Agents:** **MCCRACKIN, Ann, M.** et al.; Schwegman, Lundberg, Woessner & Kluth, PA, P.O. Box 2938, Minneapolis, MN 55402 (US).

- (81) **Designated States (unless otherwise indicated, for every kind of national protection available):** AE, AG, AL, AM, AT, AU, AZ, BA, BB, BG, BR, BW, BY, BZ, CA, CH, CN, CO, CR, CU, CZ, DE, DK, DM, DZ, EC, EE, EG, ES, FI, GB, GD, GE, GH, GM, HR, HU, ID, IL, IN, IS, JP, KE, KG, KM, KN, KP, KR, KZ, LC, LK, LR, LS, LT, LU, LV, LY, MA, MD, MG, MK, MN, MW, MX, MZ, NA, NG, NI, NO, NZ, OM, PG, PH, PL, PT, RO, RU, SC, SD, SE, SG, SK, SL, SM, SY, TJ, TM, TN, TR, TT, TZ, UA, UG, US, UZ, VC, VN, YU, ZA, ZM, ZW.
- (84) **Designated States (unless otherwise indicated, for every kind of regional protection available):** ARIPO (BW, GH, GM, KE, LS, MW, MZ, NA, SD, SL, SZ, TZ, UG, ZM, ZW), Eurasian (AM, AZ, BY, KG, KZ, MD, RU, TJ, TM), European (AT, BE, BG, CH, CY, CZ, DE, DK, EE, ES, FI, FR, GB, GR, HU, IE, IS, IT, LT, LU, LV, MC, NL, PL, PT, RO, SE, SI, SK, TR), OAPI (BF, BJ, CF, CG, CI, CM, GA, GN, GQ, GW, ML, MR, NE, SN, TD, TG).

Published:
— with international search report

For two-letter codes and other abbreviations, refer to the "Guidance Notes on Codes and Abbreviations" appearing at the beginning of each regular issue of the PCT Gazette.

(54) **Title:** WIRELESSLY COUPLED MAGNETIC RESONANCE COIL

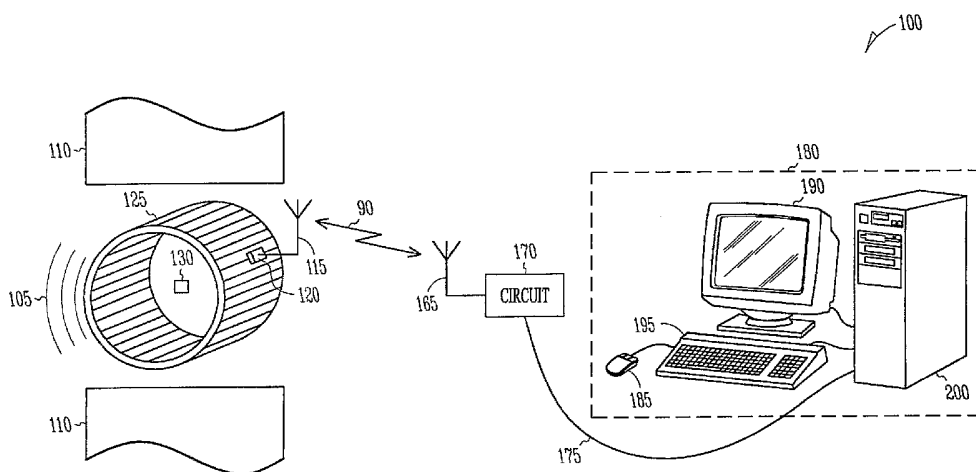

(57) **Abstract:** This document discloses a radio frequency magnetic coil (125) coupled to a wireless communication circuit (120). The wireless communication circuit allows control or monitoring of individual channels or other functions of a coil. In particular, the coil includes transmission lines.

WO 2006/121949 A1

WIRELESSLY COUPLED MAGNETIC RESONANCE COIL

Cross-Reference to Related Patent Documents

This patent application claims the benefit of priority, under 35 U.S.C. Section 119(e), to Vaughan U.S. Provisional Patent Application Serial Number 60/678,759, entitled "WIRELESSLY COUPLED MAGNETIC RESONANCE COIL," filed on May 6, 2005 (Attorney Docket No. 600.650PRV), and is incorporated herein by reference.

Technical Field

This document pertains generally to magnetic resonance, and more particularly, but not by way of limitation, to a wirelessly coupled magnetic resonance coil.

Background

Magnetic resonance (MR) coils are used for biomedical and other applications. The coils are used in magnetic resonance imaging (MRI) as well as magnetic resonance spectroscopy (MRS), electron paramagnetic resonance (EPR) and electron spin resonance (ESR), functional MRI (fMRI) and other magnetic resonance modalities.

Some magnetic resonance coils, such as a multi-channel parallel imaging coil, have 96 or more discrete channels some of which include multiple RF signal lines, power supply lines, control lines, physiological monitoring lines, communication lines, physiological stimuli lines and other electrically conductive or optically conductive lines and cables.

Each channel of a multi-channel radio frequency (RF) coils used for MR applications is electrically connected to a driver circuit, receiver circuit, or both a driver and receiver circuit. In addition, multiple cables, power lines and control lines combine to make an unwieldy bundle of cables that can impair the medical procedure. In particular, with a large number of cables, the ease of use, flexibility, versatility, quality of performance and ergonomics of the coil are reduced. Signal losses are also a problem with the long cables required.

Brief Description of the Drawings

In the drawings, which are not necessarily drawn to scale, like numerals describe substantially similar components throughout the several views. Like numerals having different letter suffixes represent different instances of
5 substantially similar components. The drawings illustrate generally, by way of example, but not by way of limitation, various embodiments discussed in the present document.

FIG. 1 schematically illustrates a magnetic resonance system having a wirelessly coupled coil.

10 FIG. 2 illustrates a garment configured with a wireless coil.

FIG. 3 illustrates an exemplary current element.

FIG. 4 illustrates an example of a passive coil.

Detailed Description

15 The following detailed description includes references to the accompanying drawings, which form a part of the detailed description. The drawings show, by way of illustration, specific embodiments in which the present subject matter may be practiced. These embodiments, which are also referred to herein as "examples," are described in enough detail to enable those
20 skilled in the art to practice the present subject matter. The embodiments may be combined, other embodiments may be utilized, or structural, logical and electrical changes may be made without departing from the scope of the present subject matter. The following detailed description is, therefore, not to be taken in a limiting sense, and the scope of the present subject matter is defined by the
25 appended claims and their equivalents.

In this document, the terms "a" or "an" are used, as is common in patent documents, to include one or more than one. In this document, the term "or" is used to refer to a nonexclusive or, unless otherwise indicated. Furthermore, all publications, patents, and patent documents referred to in this document are
30 incorporated by reference herein in their entirety, as though individually incorporated by reference. In the event of inconsistent usages between this document and those documents so incorporated by reference, the usage in the incorporated reference(s) should be considered supplementary to that of this

document; for irreconcilable inconsistencies, the usage in this document controls.

An embodiment of the present subject matter includes a magnetic resonance coil configured for wireless communication with a remote transceiver element coupled to a magnetic resonance system. A coil includes one or more
5 wireless links which provide an electrical connection for such lines as RF signal, power, control, sensor and physiological monitoring and other conductive and fiber optic lines.

Fig. 1 includes an illustration of system 100. System 100 includes main
10 magnet 110 which generates a B_0 magnetic field 105 for imaging or spectroscopy. Disposed within magnetic field 105 is radio frequency coil 125. In the example illustrated, coil 125 is a volume coil configured for imaging a specimen within region of interest 130. Coil 125 is illustrated as a transverse electro-magnetic (TEM) coil, however other types of coils can also be used,
15 including for example, birdcage structures and Helmholtz coils and phased array and parallel arrays. Coil 125 includes a number of parallel current elements, each of which is coupled to wireless circuit 120. Wireless circuit 120 is coupled to antenna 115. In various examples, circuit 120 includes a transmitter, a receiver or a transceiver.

20 As used herein, the coil can include a plurality of current elements where each current element includes a segment of a transmission line. As such, the current element can include a pair of conductors separated by a dielectric, a waveguide, a coaxial conductor segment or other transmission line.

Circuit 170 includes a wireless communication circuit which, in various
25 examples, include a transmitter, a receiver or a transceiver. Circuit 170 is coupled to antenna 165 which is in wireless communication with antenna 115 via link 90. Link 90, in one example include an optical coupling such as an infrared channel.

Circuit 170 is coupled to computer system 180 by wired connection 175.
30 Computer system 180 includes monitor 190, processor 200 and user input devices including mouse 185 and keyboard 195. Computer system 180, in one example, is coupled to a communication network (not shown) which facilitate remote operation.

In various examples, the RF coil includes an on-board transmitter, receiver or transceiver which communicates with the MR system by a wireless communication protocol.

The coil can be configured for placement on a patient while in an examining room or dressing room and worn, or carried on the body, into the MR magnet for an MR scan. In one example, wireless nanotechnology is used to introduce or implant one or more biocompatible coils into body cavities, blood vessels, orifices or into organs, tissues, or tumors without requiring a connection by means of a wire, cable or an optical fiber. The coil, in one example, includes an adhesive coated surface that bonds to a skin surface. Individual elements of the coil can be fabricated on a flexible substrate using semiconductor fabrication technology. In one example, the present subject matter includes a wireless coil in the form of a bandage.

Fig. 2 illustrates a garment configured according to the present subject matter. In the figure, system 205 includes garment 210 having coil 245 affixed thereon. Coil 245 is illustrated as a surface coil having four TEM segments 215 arranged in a planar configuration. Other coils are also contemplated, including, for example, a volume coil or phased array. Each coil segment 215 is coupled to wireless circuit 225 by connector bundle 220. Each coil segment can have its own dedicated nanotech transmitter or receiver. Wireless circuit 225 is coupled to antenna 230. Antenna 230 is also affixed to the garment. Circuit 225 can be powered by a battery or by passive excitation. The coil, or coil segments, can be affixed to the garment by stitching, adhesives, mechanical fasteners, or other means. In one example, the garment includes a fabric structure configured to be worn on a body.

FIG. 3 illustrates a portion of current element 300 according to one example of the present subject matter. In the figure, current element 300 includes first conductive member 310, dielectric 320 and second conductive member 330. A transverse electromagnetic wave resonates in current element 300 based on various parameters including the dimensions and physical properties of the structure and can be controlled by various methods.

FIG. 4 illustrates apparatus 400 according to the present subject matter. In the figure, power supply 420 is illustrated in the form of a passive

interdigitated element. In other examples, power supply 420 includes a battery, such as a rechargeable battery. Current elements 420 are disposed about a region and can be in the form of a volume, surface or other type of coil. In addition to TEM coils, other types are also contemplated, including bird cage coils. Wireless communication module 440 allows apparatus 400 to communicate with an interface coupled to a magnetic resonance system. Enclosure 410, in various examples, includes a bio-compatible housing or structure. In various examples, enclosure 410 includes a pill configured for ingestion or implantation using a surgical procedure.

10 In one example, a wireless RF coil facilitates signal and communication links from multiple components of an MR system or from multiple MR systems which may be nearby or in a remote location. For example, an adhesive-attached coil affixed to a particular patient can be used to generate a first image using a first magnetic resonance system and at a later time, a second image can be generated using a second magnetic resonance system. The adhesive-attached coil can remain affixed to a skin surface for an extended period of time amounting to days, weeks, months or years. In one example, a coil can be implanted or disposed in a body cavity for an extended period of time where the coil is passively powered or battery powered.

20 The present subject matter can be configured for use in clinical or research systems as well as animal, chemical, pharmaceutical, food processing and down hole oil well logging and other markets.

Wireless protocols used in the telecommunication industry can be adapted for use with the present subject matter. Examples of protocols include those established by standards and regulatory bodies such as the Federal Communications Commission (FCC), Mobile IP (a proposed standard protocol), Internet Engineering Task Force (IETF) and the Internet Engineering Steering Group (IESG), Pacific Telecommunications Council (PTC), International Standards Organization (ISO), International Telecommunication Union (ITU) and the National Telecommunications and Information Administration (NTIA). Specific examples of protocols include 3G (third generation), Bluetooth, Groupe Spécial Mobile (GSM), General Packet Radio Service (GPRS), Enhanced Data rates for GSM Evolution (EDGE) and third generation GSM services (3GSM*),

Universal Mobile Telecommunications System (UMTS), Code Division Multiple Access (CDMA), wideband CDMA (WCDMA), Institute of Electrical and Electronics Engineers, Inc (IEEE) 802.11 and Ultra wideband (UWB).

Wireless communication can be conducted using any of a variety of portions of the electromagnetic spectrum. For example, in addition to radio frequency communication, the present subject matter can be configured for operation using various types of radiation including infrared, visible or ultrasonic signaling.

Multi-channel radio frequency coils for MRI applications require multiple RF signal and control cables, typically to every channel in a multiple channel coil and MR system. This multiplicity of cables, power lines, and control lines often makes an unwieldy bundle limiting the overall ease of use, flexibility, versatility, quality of performance, and ergonomics of an RF coil for biomedical or other MR applications.

The present subject matter provides a means to replace hard wired (connected) RF signal lines, power lines, control lines, physiological monitoring lines, and other conductive and fiber optic lines.

The coil includes a transmitter, receiver, or transceiver in wireless communication with the MR system to eliminate some or all wires and cables connecting the coil to the system. This allows, for example, a coil to be conveniently placed on a patient in an examining or dressing room, and then “worn” into the vicinity of the MR magnet for an MR scan. Additionally, wireless nanotechnologies allows introduction or implantation of sterile coils into body cavities, blood vessels, orifices, or into organs, tissues, or tumors without the need to connect it to outside of the body by means of wire, cable, or optic fiber.

The present subject matter can be used for biomedical MR imaging, MR spectroscopy, echo planar imaging (EPI), electron spin resonance (ESR), functional MR imaging (fMRI) as well as other magnetic resonance modalities.

Certain MR techniques and technology, such as parallel imaging using multiple channels (sometimes 96 channels or more) require that an RF coil be connected to an MR system by multiple RF signal lines, power supply lines, control lines, physiological monitoring lines, communications lines,

physiological stimuli lines, and other possible conductive (wire) or optical lines and cables.

A wireless connection between the coil and the MR system allows multiple channels without the encumbrances, constraints, and problems associated with multiple hard wired connections. In addition, a wireless coil facilitates signal and communication links with the RF coil from multiple components of an MR system or multiple MR systems, nearby or remotely sited.

In one example, selected elements of the telecommunications industry are adapted for use with the present subject matter.

For example, a wireless link can include one or more infrared communication channels or Bluetooth communication channels. Bluetooth refers to a relatively short range wireless protocol using an unlicensed industrial/scientific/medicine (ISM) frequency band.

15 **Additional Examples**

In one example, the coil of the present subject matter is affixed to a garment by a stitch, mechanical fastener, adhesive or other means. The coil can be inserted into a pocket or hem of the garment or affixed in a removable manner.

In one example, the coil of the present subject matter is configured to communicate with more than one magnetic resonance system. In such a configuration, the coil is operable with any of a plurality of wireless interfaces, each coupled to a different magnetic resonance system.

In one example, a wireless interface is coupled to a magnetic resonance system and the interface provides interoperability with a plurality of wireless coils, some of which operate according to different protocols or communication modes. In one example, the magnetic resonance system is configured to allow the user to select one of a plurality of coils worn by a particular patient where each coil is in wireless communication with the system.

In one example, the coil is operable at a plurality of resonant frequencies where the frequency is manually selectable or selectable by wireless control. For example, a signal from the wireless interface allows selection of one of a

plurality of frequencies. In addition, other examples provide that a phase, a current, or a voltage of a signal can be selected manually or wirelessly.

In addition to controlling one or more selected operating parameters, one example provides that a voltage, a current, a phase or a frequency in the coil can
5 be monitored wirelessly.

In one example, a signal in the coil can be turned off or on wirelessly based on a signal received from the wireless interface and coupled to a magnetic resonance system. In one example, a coil can be detuned by means of a signal sent from the wireless interface.

10 An example of the present subject matter includes a coil controlled by a feedback signal based on monitoring of timing, phase, frequency, voltage or current.

In one example, the present subject matter includes a coil that at least partially encircles a sample or region of interest. In one example the coil is
15 disposed inside of a sample in a manner that encloses or surrounds the coil. As such, a coil can be configured for insertion in a body cavity or vessel or implantation where the coil is placed by a needle, forceps or other insertion means. Exemplary coils include those that can be deployed in a catheter, in an orally administered pill, by a minimally invasive surgical procedure (such as
20 laparoscopy) or by a needle. In various examples, the present subject matter includes a surface mounted wireless coil or a disposable wireless coil.

In one example, the present subject matter includes a wireless coil that can be fitted to a patient and used with any number of different magnetic resonance systems. For example, a coil can be placed surgically in the tissue of
25 a patient and over the course of years, magnetic resonance images can be generated for the patient using any number of different magnetic resonance systems. The coil can be worn by the patient or implanted in the patient.

It is to be understood that the above description is intended to be illustrative, and not restrictive. For example, the above-described embodiments
30 (and/or aspects thereof) may be used in combination with each other. Many other embodiments will be apparent to those of skill in the art upon reviewing the above description. The scope of the subject matter should, therefore, be determined with reference to the appended claims, along with the full scope of

equivalents to which such claims are entitled. In the appended claims, the terms “including” and “in which” are used as the plain-English equivalents of the respective terms “comprising” and “wherein.” Also, in the following claims, the terms “including” and “comprising” are open-ended, that is, a system, device,
5 article, or process that includes elements in addition to those listed after such a term in a claim are still deemed to fall within the scope of that claim. Moreover, in the following claims, the terms “first,” “second,” and “third,” etc. are used merely as labels, and are not intended to impose numerical requirements on their objects.

10 The Abstract of the Disclosure is provided to comply with 37 C.F.R. §1.72(b), requiring an abstract that will allow the reader to quickly ascertain the nature of the technical disclosure. It is submitted with the understanding that it will not be used to interpret or limit the scope or meaning of the claims. In addition, in the foregoing Detailed Description, various features may be grouped
15 together to streamline the disclosure. This method of disclosure is not to be interpreted as reflecting an intention that the claimed embodiments require more features than are expressly recited in each claim. Rather, as the following claims reflect, inventive subject matter may lie in less than all features of a single disclosed embodiment. Thus the following claims are hereby incorporated into
20 the Detailed Description, with each claim standing on its own as a separate embodiment.

What is claimed is:

1. A radio frequency magnetic resonance coil comprising:
at least one current element; and
a wireless communication circuit coupled to the at least one current element.
2. The coil of claim 1 wherein the wireless communication circuit includes at least one of a transmitter, a receiver, and a transceiver.
3. The coil of claim 1 wherein the at least one current element includes a transmission line.
4. The coil of claim 1 wherein the at least one current element is configured as a volume coil or a surface coil.
5. The coil of claim 1 wherein the at least one current element is configured for receiving a radio frequency signal from a region of interest.
6. The coil of claim 1 wherein the at least one current element is configured for transmitting a radio frequency signal to a region of interest.
7. The coil of claim 1 wherein the wireless communication circuit is configured to communicate with at least one magnetic resonance system.
8. The coil of claim 1 wherein the at least one current element is configured for resonance at a frequency that is selected based on a signal received from the wireless communication circuit.
9. The coil of claim 1 wherein a parameter corresponding to a transverse electromagnetic signal in the at least one current element is selected based on a control signal received from the wireless communication circuit.

10. The coil of claim 9 wherein the parameter includes at least one of a phase, a current, and a voltage.
11. The coil of claim 9 wherein the transverse electromagnetic signal can be detuned based on the control signal received from the wireless communication circuit.
12. The coil of claim 1 wherein a parameter corresponding to a transverse electromagnetic signal in the at least one current element is monitored based on a control signal received from the wireless communication circuit.
13. The coil of claim 12 wherein the parameter includes at least one of a current, a voltage, a frequency, and a phase.
14. The coil of claim 1 wherein a transverse electromagnetic signal in the at least one current element is determined based on a feedback signal generated as a function of a monitored parameter.
15. The coil of claim 1 wherein the at least one current element and the wireless communication circuit are configured for at least one of implantation and ingestion.
16. The coil of claim 1 wherein the at least one current element and the wireless communication circuit are configured for deployment in at least one of a catheter and a needle.
17. The coil of claim 1 wherein the at least one current element and the wireless communication circuit are configured for insertion using minimally invasive means.
18. The coil of claim 1 further including a surface mount substrate coupled to the at least one current element and the wireless communication circuit.

19. The coil of claim 18 wherein the substrate includes a flexible material.
20. The coil of claim 1 wherein the at least one current element and the wireless communication circuit are disposable.
21. The coil of claim 1 further including a bandage coupled to the at least one current element and the wireless communication circuit.
22. The coil of claim 1 further including an adhesive coupled to the at least one current element and the wireless communication circuit.
23. A method comprising:
 - arranging a radio frequency magnetic resonance coil having a current element disposed about a region of interest; and
 - communicating with the coil using a wireless communication protocol.
24. The method of claim 23 wherein communicating includes receiving a radio frequency signal based on a current in the coil.
25. The method of claim 23 wherein communicating includes transmitting a radio frequency signal corresponding to a current in the coil.
26. An apparatus comprising:
 - a coil configured for use with a magnetic resonance system;
 - a wireless interface coupled to the coil; and
 - a garment coupled to the coil.
27. The apparatus of claim 26 wherein the garment includes a fabric structure configured to be worn on a body.
28. The apparatus of claim 26 wherein the coil includes a plurality of transmission line segments.

29. The apparatus of claim 28 wherein the wireless interface is coupled to each transmission line segment.

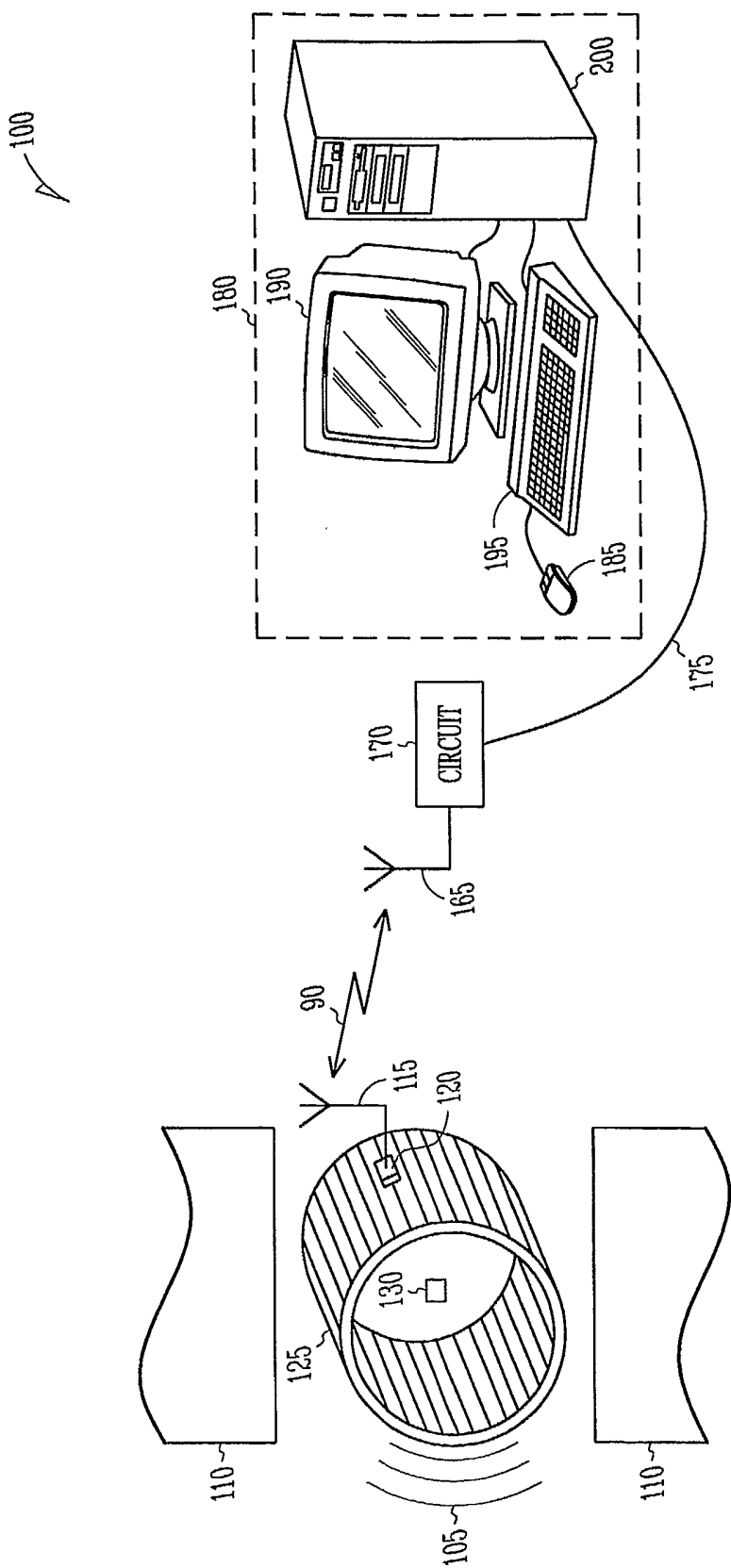

FIG. 1

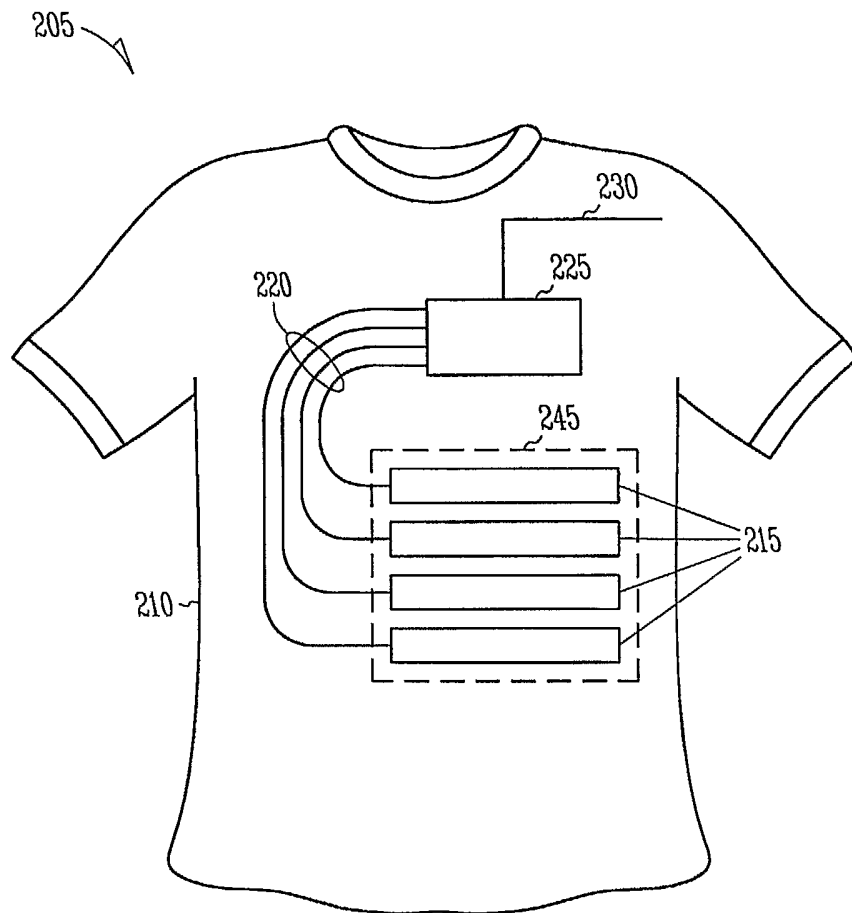

FIG. 2

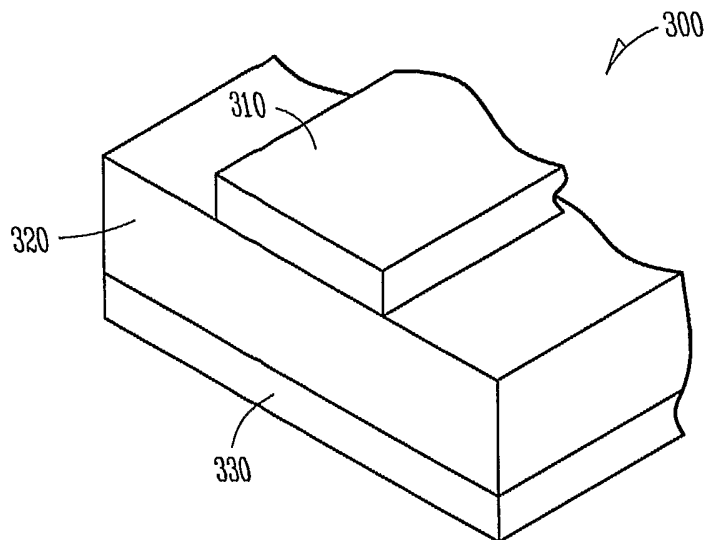

FIG. 3

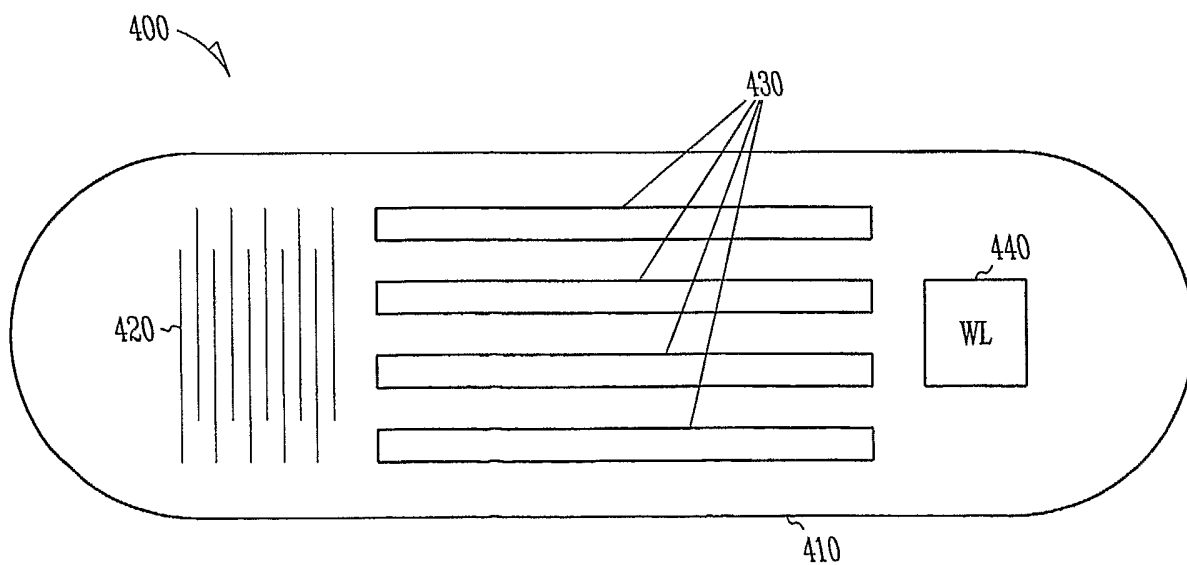

FIG. 4

INTERNATIONAL SEARCH REPORT

International application No
PCT/US2006/017576

<p>A. CLASSIFICATION OF SUBJECT MATTER INV. G01R33/36 ADD. G01R33/345</p>		
<p>According to International Patent Classification (IPC) or to both national classification and IPC</p>		
<p>B. FIELDS SEARCHED</p>		
<p>Minimum documentation searched (classification system followed by classification symbols) G01R A61B G01N</p>		
<p>Documentation searched other than minimum documentation to the extent that such documents are included in the fields searched</p>		
<p>Electronic data base consulted during the international search (name of data base and, where practical, search terms used) EPO-Internal, INSPEC, EMBASE, BIOSIS, WPI Data, PAJ, MEDLINE, COMPENDEX</p>		
<p>C. DOCUMENTS CONSIDERED TO BE RELEVANT</p>		
Category*	Citation of document, with indication, where appropriate, of the relevant passages	Relevant to claim No.
X	US 5 384 536 A (MURAKAMI ET AL) 24 January 1995 (1995-01-24)	1,2,4-7, 20,23-25
Y	column 2, line 58 - line 62 column 5, line 23 - line 36	15,17, 21,22, 26-29
X	WO 03/032002 A (KONINKLIJKE PHILIPS ELECTRONICS N.V; PHILIPS MEDICAL SYSTEMS , INC) 17 April 2003 (2003-04-17)	1,2,4-8, 20,23-25
Y	page 5, line 7 - line 13; figure 1	3,9-14, 18,19, 28,29
<p><input checked="" type="checkbox"/> Further documents are listed in the continuation of Box C. <input checked="" type="checkbox"/> See patent family annex.</p>		
<p>* Special categories of cited documents :</p>		
<p>"A" document defining the general state of the art which is not considered to be of particular relevance</p>		<p>"T" later document published after the international filing date or priority date and not in conflict with the application but cited to understand the principle or theory underlying the invention</p>
<p>"E" earlier document but published on or after the international filing date</p>		<p>"X" document of particular relevance; the claimed invention cannot be considered novel or cannot be considered to involve an inventive step when the document is taken alone</p>
<p>"L" document which may throw doubts on priority claim(s) or which is cited to establish the publication date of another citation or other special reason (as specified)</p>		<p>"Y" document of particular relevance; the claimed invention cannot be considered to involve an inventive step when the document is combined with one or more other such documents, such combination being obvious to a person skilled in the art.</p>
<p>"O" document referring to an oral disclosure, use, exhibition or other means</p>		<p>"&" document member of the same patent family</p>
<p>"P" document published prior to the international filing date but later than the priority date claimed</p>		
<p>Date of the actual completion of the international search 21 August 2006</p>		<p>Date of mailing of the international search report 28/08/2006</p>
<p>Name and mailing address of the ISA/ European Patent Office, P.B. 5818 Patentlaan 2 NL - 2280 HV Rijswijk Tel. (+31-70) 340-2040, Tx. 31 651 epo nl, Fax: (+31-70) 340-3016</p>		<p>Authorized officer Skalla, J</p>

INTERNATIONAL SEARCH REPORT

International application No

PCT/US2006/017576

C(Continuation). DOCUMENTS CONSIDERED TO BE RELEVANT		
Category*	Citation of document, with indication, where appropriate, of the relevant passages	Relevant to claim No.
Y	WO 02/31522 A (REGENTS OF THE UNIVERSITY OF MINNESOTA; ZHANG, XIAOLIANG; UGURBIL, KAM) 18 April 2002 (2002-04-18) page 5, line 1 - page 6, line 30; figures 2A,4	3,9-14, 18,19, 28,29
X	----- US 5 245 288 A (LEUSSLER ET AL) 14 September 1993 (1993-09-14) claim 1	1,2,4-7, 20,23-25
X	----- DE 44 40 619 A1 (MEDRAD, INC., PITTSBURGH, PA., US) 31 August 1995 (1995-08-31) column 2, line 51 - column 3, line 37; figure 1	1,2,4-7, 20,23-25
X	----- WO 03/093852 A (GE MEDICAL SYSTEMS GLOBAL TECHNOLOGY COMPANY, LLC) 13 November 2003 (2003-11-13) pages 2,6	1,2,4-7, 20,23-25
X	----- US 2003/078004 A1 (VESTER MARKUS) 24 April 2003 (2003-04-24) paragraphs [0006], [0007]	1,2,4-7, 20,23-25
X	----- WO 2005/024448 A (KONINKLIJKE PHILIPS ELECTRONICS, N.V; U.S. PHILIPS CORPORATION; DEN B0) 17 March 2005 (2005-03-17) page 10, line 6 - line 19	1,2,4-7, 20,23-25
X	----- WO 01/75466 A (CASE WESTERN RESERVE UNIVERSITY; DUERK, JEFFREY, L; WENDT, MICHAEL; WO) 11 October 2001 (2001-10-11) page 10, line 1 - line 6	1,2,4-7, 20,23-25
X	----- US 5 545 999 A (MUELLER ET AL) 13 August 1996 (1996-08-13) column 4, line 50 - line 65	1,2,4-7, 20,23-25
X	----- US 5 666 055 A (JONES ET AL) 9 September 1997 (1997-09-09) column 5, line 37 - line 50	1,23
Y	----- US 6 084 411 A (GIAQUINTO ET AL) 4 July 2000 (2000-07-04) column 4, line 40 - line 58	26,27
Y	----- US 2002/151788 A1 (MENON ASHOK) 17 October 2002 (2002-10-17) paragraphs [0006], [0007]	26,28,29
	-/--	

INTERNATIONAL SEARCH REPORT

International application No

PCT/US2006/017576

C(Continuation). DOCUMENTS CONSIDERED TO BE RELEVANT		
Category*	Citation of document, with indication, where appropriate, of the relevant passages	Relevant to claim No.
Y	MORIKAWA S ET AL: "Long-term observation of in vivo ³¹ P NMR spectra in carbon tetrachloride-intoxicated rabbit liver using implanted wireless surface coil" NMR IN BIOMEDICINE UK, vol. 8, no. 1, February 1995 (1995-02), pages 3-8, XP009071175 ISSN: 0952-3480 page 3, left-hand column - page 4, left-hand column -----	15,17
Y	PATENT ABSTRACTS OF JAPAN vol. 1997, no. 07, 31 July 1997 (1997-07-31) -& JP 09 075323 A (TOSHIBA CORP), 25 March 1997 (1997-03-25) abstract -----	21,22
P,X	WO 2006/000928 A (KONINKLIJKE PHILIPS ELECTRONICS, N.V; U.S. PHILIPS CORPORATION; LUEDEK) 5 January 2006 (2006-01-05) claims 1,2,11,12 -----	1,2,4-7, 20,23-25
P,X	WO 2005/052621 A (KONINKLIJKE PHILIPS ELECTRONICS, N.V; U.S. PHILIPS CORPORATION; OVERWE) 9 June 2005 (2005-06-09) claim 9 -----	1,2,4-7, 20,23-25
A	US 2004/054278 A1 (KIMCHY YOAV ET AL) 18 March 2004 (2004-03-18) paragraphs [0083], [0335], [0349] -----	1,15

INTERNATIONAL SEARCH REPORT

Information on patent family members

International application No PCT/US2006/017576

Patent document cited in search report	A	Publication date	Patent family member(s)	Publication date
US 5384536	A	24-01-1995	JP 3168675 B2 JP 5261083 A	21-05-2001 12-10-1993
WO 03032002	A	17-04-2003	EP 1438601 A1 JP 2005505361 T US 6961604 B1	21-07-2004 24-02-2005 01-11-2005
WO 0231522	A	18-04-2002	AU 9673801 A EP 1344076 A1 JP 2004511278 T JP 2005270674 A	22-04-2002 17-09-2003 15-04-2004 06-10-2005
US 5245288	A	14-09-1993	DE 4126537 A1 EP 0527530 A1 JP 3187152 B2 JP 5261085 A	11-02-1993 17-02-1993 11-07-2001 12-10-1993
DE 4440619	A1	31-08-1995	FR 2716724 A1 NL 9402017 A	01-09-1995 02-10-1995
WO 03093852	A	13-11-2003	AU 2003220020 A1 US 2003206019 A1	17-11-2003 06-11-2003
US 2003078004	A1	24-04-2003	CN 1430067 A DE 10148462 C1	16-07-2003 18-06-2003
WO 2005024448	A	17-03-2005	EP 1664820 A1	07-06-2006
WO 0175466	A	11-10-2001	AU 5107801 A	15-10-2001
US 5545999	A	13-08-1996	NONE	
US 5666055	A	09-09-1997	NONE	
US 6084411	A	04-07-2000	US 5905378 A	18-05-1999
US 2002151788	A1	17-10-2002	NONE	
JP 09075323	A	25-03-1997	NONE	
WO 2006000928	A	05-01-2006	NONE	
WO 2005052621	A	09-06-2005	EP 1690104 A1	16-08-2006
US 2004054278	A1	18-03-2004	NONE	