

*P. J. Hynes,*

*Boring Artesian Wells*

*N<sup>o</sup> 51,692*

*Patented Dec. 19, 1865.*

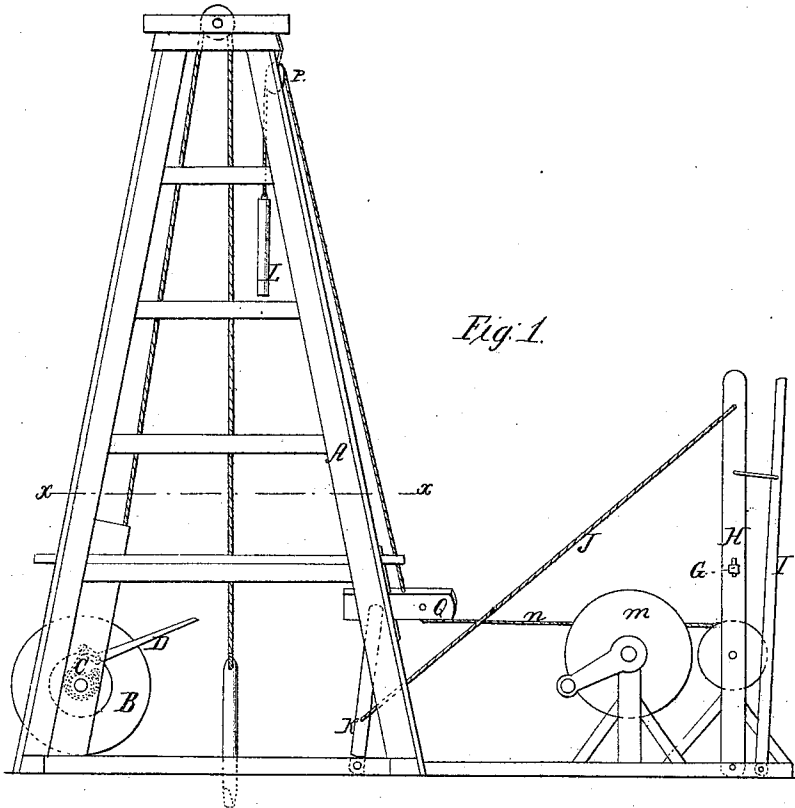

*Fig. 1.*

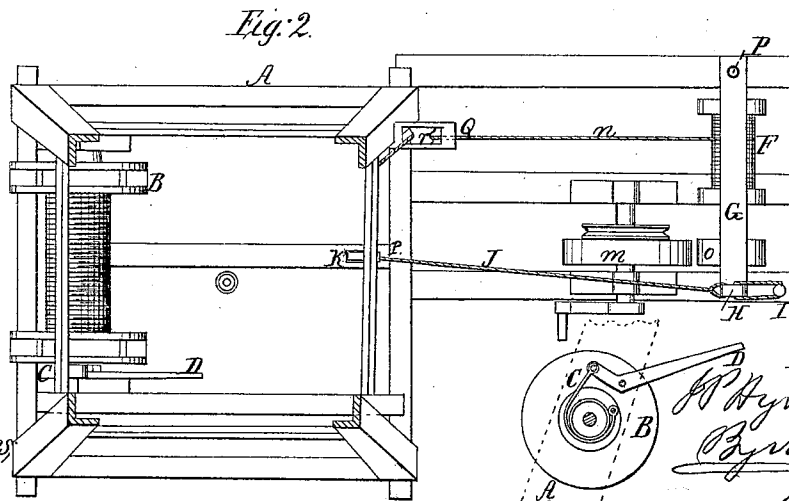

*Fig. 2.*

*Witnesses,  
G. M. Livingston  
Wm. Brown*

*Inventor,  
P. J. Hynes  
By Munnsey  
P. M.*

# UNITED STATES PATENT OFFICE.

P. J. HYNES, OF COOPERSTOWN, PENNSYLVANIA.

## IMPROVEMENT IN BORING WELLS.

Specification forming part of Letters Patent No. 51,592, dated December 19, 1865.

*To all whom it may concern:*

Be it known that I, P. J. HYNES, of Cooperstown, in the county of Venango and State of Pennsylvania, have invented a new and useful Improvement in Apparatus for Boring Wells; and I do hereby declare that the following is a full, clear, and exact description thereof, which will enable others skilled in the art to make and use the same, reference being had to the accompanying drawings, forming part of the specification, in which—

Figure 1 is a side elevation of a derrick for supporting and operating tools and devices used in boring oil and other deep wells. Fig. 2 is a plan view, part of which is a horizontal section taken in the line *x* of Fig. 1.

Similar letters of reference indicate like parts.

The object of this invention is to improve some of the devices and appliances used in connection with a derrick for boring oil and other deep wells; and it consists in applying a brake to the windlass on which the drill-rope is wound, so as to control the descent of the drill when it is to be lowered in preparation for work; also, in placing a pulley in front of the windlass of the said pump-rope, so that the rope shall be wound thereon square, although the windlass may not be directly in front of the derrick; also, in a mode of making the frame which sustains the windlass of the sand-pump rope.

A designates a derrick, made in any suitable manner and designed to support the windlass, pulleys, and other appliances required in boring a deep well. The drill is here seen suspended from a rope which passes over a pulley in the top of the derrick and is thence conducted to a windlass, B, whose axle has its bearings in posts secured to the derrick.

In letting the drill, which usually is very heavy, into a well it is necessary to retard its descent when it approaches the bottom of the bore, to prevent bending or fracture of the parts. This retardation is usually accomplished at present by means of a rope applied on the outside of the axle or of one of the flanges of the windlass and fastened to one of the girths of the derrick. This plan is objectionable, because the rope sometimes gets burned and becomes broken, letting the drill or other tool fall in the well from a great height,

causing them to become so bent by the violent concussion that they cannot be taken out again, and the consequence is that the well must be abandoned.

My invention provides a remedy for this state of things by attaching a metallic band, C, to one of the posts that support the windlass B in such a way as that it shall nearly envelop the axle of the windlass at one end thereof, which end is, moreover, bound around with iron to prevent the burning of the axle when the friction-band is brought close around it. The upper end of the metallic band is attached to a lever, D, which has its fulcrum in said windlass-post, and when the lever is depressed the metallic band is brought against the axle, so as to act as a brake and retard its motion. By this means the attendant can always control the rapidity of descent of the tools into a well.

Another feature of my invention relates to the control of the sand-pump rope.

L is the sand-pump, suspended from a rope which passes over a pulley fixed in the top of the derrick. The windlass which holds this rope is placed at one side of the middle of the derrick, out of line with the well, for convenience in arranging and disposing some of the machinery (not here shown) connected with the operation of boring a well, and for other purposes, as seen in Fig. 2.

F designates the windlass of the sand-pump rope. The standard H, in which one end of its axle is supported, is so connected to its platform or bed as to be capable of motion at right angles to the axis of the windlass, so that it can bring the friction-pulley *o* up against or away from the periphery of the driving-wheel *m*, thereby causing the rope to be wound on or off the windlass as is required by the work.

A rope, J, extends from the top of the standard H to an upright lever, K, pivoted to the floor of the derrick near the bore of the well, so that the attendant can, without moving from his place, bring the pulley *o* up against the driving-pulley and wind up the rope of the sand-pump by merely drawing the lever K toward the left.

The standard H is drawn back so as to carry the pulley *o* away from the wheel *m* by means of a lever, I, which is connected to the upper part of the standard by a cord or wire.

The lever I may be operated by hand or it may be continually drawn toward the right by a weight or spring.

The standard P, which supports the outer end of the windlass F, is mostly concealed by the cap G. This cap is connected to the standard H by a mortise-and-tenon joint, and to the standard P by a pivot-hinge, so that it can have motion about the standard P as about a center when the standard H is moved forward or backward. The cap serves to connect the standards H and P and tends to prevent the shaft from becoming loose and out of order in its bearings.

The rope *n* is conducted from the windlass F to a pulley, *r*, running in a block, Q, that is fastened to the derrick. The position of this pulley is directly opposite the middle of the

windlass F, so that the rope is continually in a direction at right angles, or nearly so, with the windlass. Hitherto the rope has been conducted from the windlass F directly up to pulleys in the top of the derrick, causing the rope to extend in an oblique direction, whereby it was wound in a heap at one end of the windlass.

I claim as new and desire to secure by Letters Patent—

Connecting the cap G of the frame of the sand-pump windlass to the rigid standard P by a pivot, and to the loose standard H by a fixed joint, substantially as and for the purpose above described.

P. J. HYNES.

Witnesses:

J. P. BYERS,

J. W. BYERS.