

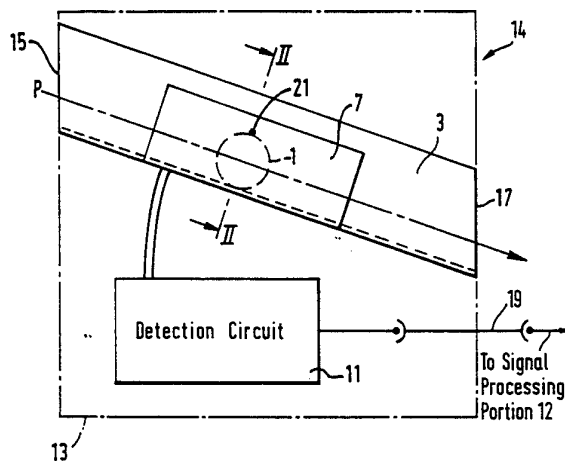

INTERNATIONAL APPLICATION PUBLISHED UNDER THE PATENT COOPERATION TREATY (PCT)

(51) International Patent Classification ⁵ : G07F 3/02	A1	(11) International Publication Number: WO 94/09452 (43) International Publication Date: 28 April 1994 (28.04.94)
(21) International Application Number: PCT/GB93/02119 (22) International Filing Date: 13 October 1993 (13.10.93) (30) Priority data: 9221591.2 14 October 1992 (14.10.92) GB 9314508.4 13 July 1993 (13.07.93) GB (71) Applicant (for all designated States except US): TETREL LIMITED [GB/GB]; Llantrisant Business Park, Llantrisant, Mid-Glam. CF7 8LF (GB). (72) Inventor; and (75) Inventor/Applicant (for US only) : CHURCHMAN, James [GB/GB]; The Croft, Llysworney, South Glamorgan CF7 7NQ (GB). (74) Agents: BERESFORD, Keith, Denis, Lewis et al.; Beresford & Co, 2-5 Warwick Court, High Holborn, London WC1R 5DJ (GB).		(81) Designated States: JP, US, European patent (AT, BE, CH, DE, DK, ES, FR, GB, GR, IE, IT, LU, MC, NL, PT, SE). Published <i>With international search report.</i> <i>Before the expiration of the time limit for amending the claims and to be republished in the event of the receipt of amendments.</i>

(54) Title: COIN VALIDATORS**(57) Abstract**

In a coin detection system a coin (1) passes between conductive plates (7, 9) which form a capacitor, which provides part of the frequency controlling capacitance of an LC tuned oscillator circuit (23). The presence of a coin (1) between the conductive plates (7, 9) alters the capacitance, and consequently alters the output frequency of the oscillator circuit (23). The oscillator output is supplied to the clock of a counter (31), optionally following frequency division in a frequency divider (27). The counter (31) counts the number of clock pulses received in a 10ms period, and the count value is provided to a microprocessor (75) via a shift register (33). The count value will be a measure of the frequency of the output of the oscillator (23). Microprocessor (75) subtracts the count value from a pre-stored reference value, and supplies the difference to a look-up table (47) stored in a memory (37). The microprocessor (75) uses the output of the look-up table (47) to determine whether a valid coin has been received, and if so, what the denomination of the valid coin is. The pre-stored reference value represents the frequency of the output of the oscillator (23) when no coin is present. Preferably, while no coin is present the microprocessor (39) monitors the count values obtained from the counter (31), and updates the stored reference value so that it tracks drift in the frequency of the oscillator (23).

FOR THE PURPOSES OF INFORMATION ONLY

Codes used to identify States party to the PCT on the front pages of pamphlets publishing international applications under the PCT.

AT	Austria	FR	France	MR	Mauritania
AU	Australia	GA	Gabon	MW	Malawi
BB	Barbados	GB	United Kingdom	NE	Niger
BE	Belgium	GN	Guinea	NL	Netherlands
BF	Burkina Faso	GR	Greece	NO	Norway
BG	Bulgaria	HU	Hungary	NZ	New Zealand
BJ	Benin	IE	Ireland	PL	Poland
BR	Brazil	IT	Italy	PT	Portugal
BY	Belarus	JP	Japan	RO	Romania
CA	Canada	KP	Democratic People's Republic of Korea	RU	Russian Federation
CF	Central African Republic	KR	Republic of Korea	SD	Sudan
CG	Congo	KZ	Kazakhstan	SE	Sweden
CH	Switzerland	LI	Liechtenstein	SI	Slovenia
CI	Côte d'Ivoire	LK	Sri Lanka	SK	Slovak Republic
CM	Cameroon	LU	Luxembourg	SN	Senegal
CN	China	LV	Latvia	TD	Chad
CS	Czechoslovakia	MC	Monaco	TG	Togo
CZ	Czech Republic	MG	Madagascar	UA	Ukraine
DE	Germany	ML	Mali	US	United States of America
DK	Denmark	MN	Mongolia	UZ	Uzbekistan
ES	Spain			VN	Viet Nam
FI	Finland				

- 1 -

COIN VALIDATORS

This invention relates to coin validators such as for use in pay telephones or vending machines.

5 It should be understood that the word "coin" as used herein is not limited to money in general circulation, but may cover a token or slug of any form regardless of whether it has any monetary value and the term "coin validation" is intended to cover the
10 validation such of tokens or slugs.

There have been proposed, e.g. in GB-A-2062327 and US-A-4184366, systems for detecting whether a coin exceeds a threshold diameter, by providing a first capacitor plate spaced from a second capacitor plate.
15 As a coin passes along a coin chute, it will overlap both capacitor plates at the same time, thereby coupling a signal from one plate to the other, if the coin is large enough to bridge the space between the plates. Therefore the presence or absence of the
20 signal indicates whether the coin exceeds the threshold diameter. Such a system cannot measure the coin diameter, but merely decides whether it exceeds the threshold. US-A-4184366 provides a plurality of second capacitor plates to provide a plurality of
25 diameter thresholds.

GB-A-1464371 and WO 86/06246 propose a capacitor the capacitance of which is altered by a passing coin. In GB-A-1464371 a signal at a preset frequency is applied to the capacitor and the amplitude of the
30 current flow through the capacitor is detected. In WO 86/06246 the capacitor is provided in an RC circuit to which a signal at a preset frequency is applied, and the amplitude of the current in the RC circuit is detected. In each case, the amplitude is a measure of
35 a property of the coin, and accordingly it can be

- 2 -

5 applied to threshold detectors to determine whether the property of the coin exceeds corresponding thresholds. GB-A-2174227 proposes a system in which a voltage change is caused by a coin passing between capacitor plates and the size of the change is digitised and supplied to a microprocessor.

10 GB-A-994736 proposes a system in which a coin alters the capacitance of a capacitor in a resonant circuit, thereby altering the Q value of the resonant circuit. The resonant circuit is provided in an oscillator feedback loop so that the oscillator either will or will not oscillate depending on the Q value. Accordingly, the presence or absence of an oscillator output while a coin is present provides a threshold
15 detection of a property of the coin.

GB-A-2174227 and US-A-4184366, referred to above, also both propose that the coin is used to affect the inductance of a coil. In GB-A-2174227, the inductance change is detected by detecting the change in resonant
20 amplitude of a resonant circuit comprising the coil, as described in GB-A-2169429. In US-A-4184336, the inductance change is detected by detecting the change in the frequency of an oscillator controlled by a tuned circuit comprising the coil.

25 FR-A-2353911 proposes an arrangement in which coins drop in free fall between the plates of a capacitor. The capacitor is part of a tuned circuit for an oscillator, tuned to 1MHz when idle. The presence of a coin increases the capacitance of the capacitor and therefore reduces the frequency of the
30 oscillator by 100 to 200kHz. The frequency change depends on both the thickness and the diameter of the coin. The frequency is measured in a counter. A read-only memory stores thresholds for sorting and
35 validating coins. One of the bits of the read-only

- 3 -

memory serves to keep the oscillation at a fixed value in the absence of a coin.

5 In one aspect, the present invention provides a system in which a coin affects a capacitance so as to alter the frequency of an oscillator, and the altered oscillator frequency and a further value are both used to determine which of a plurality of acceptable coins has been input. The further value may be either (i) the altered oscillator frequency when the coin is
10 affecting the capacitance differently because the physical parameters determining the interaction of the coin and the capacitance are different at different points on the coin path, or (ii) a value representing a coin parameter other than its effect on the
15 capacitance.

In another aspect, the invention provides a coin validation system comprising a detection circuit including a coin sensor and a guide means arranged to guide a coin to be validated between conductive plates
20 to cause a change in the frequency of a signal in the detection circuit which change is indicative of the denomination and validity of the coin, the detection circuit also obtaining a further signal, representing either a further change in the frequency of the signal
25 in the detection circuit or representing a different effect of the coin.

The effect of the coin on the capacitance depends on its thickness and its area, and also its permittivity in the case of a non-conductive coin.
30 Therefore different coins can have the same effect on a capacitance so that a single capacitance measurement cannot distinguish them. If the parameters of the capacitance are altered, confusable coins will normally become distinguishable. Alternatively,
35 another effect or feature of the coin, such as its

- 4 -

effect on an inductance or its diameter, can be used to distinguish confusable coins. In this way, the further value or signal assists in distinguishing between coins which are confusable on the basis of a single change in frequency.

In another aspect of the present invention, an input coin is arranged to affect a capacitance so as to alter an oscillation frequency, a detection circuit uses the value of the altered frequency as a measure of coin identity, and a compensation arrangement compensates the operation of the detection circuit for changes over time in the value of the oscillation frequency in the absence of a coin.

According to a further aspect of the present invention, a coin testing or validating arrangement comprises a coin guide for guiding an input coin between walls past conductive plates to alter the capacitance provided by the conductive plates, and means for detecting the alteration in the capacitance caused by the coin, the coin guide having a dielectric member fixed to one of the walls.

The dielectric member allows a single coin guide to be manufactured for use with a variety of coin sets, and the coin guide to be adapted for use with a particular coin set by choosing a dielectric member having a thickness chosen with reference to the thickest coin of the coin set. Additionally, if it is desired to provide different regions of the conductive plates with different capacitive properties, this can be done by altering the dielectric effect of the coin guide in these regions. To achieve this result, an appropriately designed dielectric member, e.g. with variable height, thickness or composition, can be fitted to the coin guide.

In another aspect of the present invention, coin

- 5 -

validating apparatus guides a coin past a capacitor means to affect the capacitance thereof, and past an inductor means to affect the inductance thereof; an oscillator circuit outputs a signal the frequency of which is affected by both the capacitance of the capacitor means and the inductance of the inductor means, and the frequency of the output of the oscillator circuit is used to reject or identify the coin.

The inductor means is not necessarily highly sensitive to the size of the coin, but will respond to the magnetic properties of the material of the coin. In this way, it can distinguish between ferromagnetic coins and paramagnetic coins having the same effect on the capacitor means.

Embodiments of the invention, given by way of non-limiting example, will now be described with reference to the accompanying drawings, in which:

Figure 1 is a side view of the coin sensing portion of a coin validation system according to an embodiment of the invention;

Figure 2 is a section along the line II-II of Figure 1;

Figure 3 is an electrical block diagram of the coin validator of Figure 1 and Figure 2;

Figure 4 is a schematic diagram of a memory in the circuit of Figure 3;

Figure 5a is a diagram illustrating a coin moving between the sensor plates of the embodiment of Figure 1;

Figure 5b is a diagram which illustrates signals produced in the circuitry of Figure 3 as a coin moves between the sensor plates of Figure 5a;

Figure 6 shows an example of an oscillator circuit which may be used in the circuit of Figure 3;

- 6 -

Figure 7 is a circuit diagram of an alternative embodiment of an oscillator circuit for detector circuitry of a coin validator.

5 Figure 8 is a schematic top view of a coin guide;

Figure 9 is an electrical model of the coin guide of Figure 8;

10 Figure 10 is a schematic top view of the coin guide of Figure 8 when a coin is passing along it;

Figure 11 is an electrical model of the coin guide of Figure 10 together with the coin;

Figures 12a and 12b are diagrams similar to Figures 5a and 5b but showing a second embodiment;

15 Figures 13a and 13b are diagrams similar to Figures 5a and 5b but showing a third embodiment;

Figures 14a and 14b are diagrams similar to Figures 5a and 5b but showing a fourth embodiment;

Figure 15 is a schematic side view of a side wall of a coin guide according to a fifth embodiment;

20 Figure 16 is a schematic end view of the coin guide of the embodiment of Figure 15;

Figure 17 is a schematic side view of the side wall of a coin guide in a sixth embodiment;

25 Figure 18 is a schematic end view of the coin guide of the embodiment of Figure 17;

Figure 19 is a schematic side view of a side wall of a coin guide in a seventh embodiment;

Figure 20 is a schematic top view of the coin guide of the embodiment of Figure 19;

30 Figure 21 is a schematic side view of a side wall of a coin guide in a eighth embodiment;

Figure 22 is a schematic top view of the coin guide of the embodiment of Figure 21;

35 Figure 23 is a schematic end view of the coin guide of the embodiment of Figure 21;

- 7 -

Figure 24 is a schematic side view of the side wall of a coin guide in a ninth embodiment;

Figure 25 is a schematic end view of the coin guide of the embodiment of Figure 24;

5 Figure 26 is a schematic side view of an insert for attaching to a side wall of a coin guide;

Figure 27 is a schematic end view of a coin guide with the insert of Figure 26;

10 Figure 28 is a schematic side view of an insert of stepped height;

Figure 29 is a schematic top view of an insert with stepped thickness;

Figure 30 is a schematic side view of an insert with regions of different electrical permittivity;

15 Figure 31 shows a section similar to Figure 2 but showing a further embodiment of the invention;

Figures 32a and 32b are similar to Figures 5a and 5b but showing the embodiment of Figure 31;

20 Figure 33 is an example of an oscillator circuit for use in the embodiment of Figures 31 and 32, which circuit is a modification of the circuit of Figure 6; and

Figure 34 is an electrical block diagram showing an alternative circuit to that shown in Figure 3.

25 Figures 1 to 4 show a coin validation system, which is for receiving and discriminating between valid and invalid coins and determining the denomination of valid coins. The system comprises a coin sensing portion 14, shown in schematic side view in Figure 1.

30 In Figure 1, a coin 1 enters the coin sensing portion 14 through an aperture 15, and rolls down a longitudinally inclined guide 3 which defines a coin path P.

35 As the coin 1 rolls down the guide 3, it passes

- 8 -

between conductive plates 7, 9, which form a capacitor. The presence of the coin 1 between the conductive plates 7, 9 will alter the capacitance of the capacitor, and this alteration is detected by a detection circuit 11 as will be described later. As can be seen in Figure 2, the conductive plates 7, 9 are provided on the outside of walls of the guide 3, so that the coin 1 does not contact them. This protects the conductive plates 7, 9 from mechanical abrasion by the coin 1. Additionally, the guide 3 is made of non-conductive material so as to insulate electrically the conductive plates 7, 9 from each other.

The guide 3 has a U-shaped section, with a wall-to-wall separation of about 4mm. It is also inclined laterally as shown in Figure 2. The lateral inclination is not shown in Figure 1 for clarity. The lateral inclination of the guide 3 causes the coin 1 to rest against side wall 2 of the guide 3 as well as resting on the floor 4 of the guide 3. Consequently the radial direction of the coin 1 is maintained parallel to the conductive plates 7, 9 and the position of the coin across the width of the gap between the conductive plates 7, 9 is determined. This causes all coins to follow the same coin path P, to enable consistent detection of coins.

The conductive plates 7, 9 preferably extend from the bottom of the guide 3 up to a height equal to or slightly greater than the height of the greatest diameter coin intended to be accepted by the validator.

The conductive plates 7, 9 may be provided by any convenient method, such as plating them onto the guide 3 using printed circuit techniques, printing them with a conductive ink, or by adhering pieces of

- 9 -

metal (e.g. copper or copper alloy) foil to the guide 3.

5 The detection circuit 11 is provided on a circuit board mounted alongside the guide 3, and spaced about 10mm to 15mm from it, as shown in Figure 2.

10 The sensing portion 14 of the coin validation system is enclosed in a protective box 13, which may be RF-shielding, in which aperture 15 is provided. At the end of the guide 3 the coin 1 leaves the protective box 13 through an exit aperture 17.

15 Figure 3 shows the electrical circuit of the coin validation system in block form. The detection circuit 11, for detecting alteration in the capacitance of the capacitor formed by the conductive plates 7, 9, is provided inside the protective box 13. It is connected to a signal processing portion 12, which is outside the protective box 13, by a coaxial cable 19.

20 As shown in Figure 3, the detection circuit 11 comprises an oscillator circuit 23 to which the conductive plates 7, 9 are connected. The frequency at which the oscillator circuit 23 oscillates depends on the capacitance of the capacitor formed by the conductive plates 7, 9. The oscillator circuit 23 is
25 tuned to oscillate at a predetermined nominal rest frequency, for example 192 MHz, when no coin is present between conductive plates 7, 9. The oscillator circuit 23 has an output fed via a buffer
30 25 to a frequency divider 27. The frequency divider 27 divides the frequency of its input by, for example, 32 to produce a nominal rest output frequency of, for example, 6 MHz when no coin is present between conductive plates 7, 9. The rest frequency is the frequency when no coin is present.

35 The oscillator circuit 23 may be implemented as

- 10 -

shown in Figure 6, in which capacitor C represents the capacitance of the conductive plates 7, 9 and the path P of the coin 1 is shown passing between the conductive plates 7,9. In Figure 6, the oscillator circuit 23 is an LC tuned oscillator. The values of the capacitance and inductance in the circuit will determine the oscillator frequency. The capacitance provided by the conductive plates 7, 9 can be arranged to be of the order of 2 to 3 pF. This should provide a significant proportion of the total capacitance in the circuit, so that alterations of this capacitance due to the presence of a coin will result in a detectable change in the resonant frequency.

In the circuit of Figure 6, the collector of the transistor in the oscillator circuit 23 has a low impedance connection to ground for a.c. signals at the resonant frequency whereas the connection between the capacitors and the inductor has a high impedance connection to ground for a.c. signals at the resonant frequency. Therefore the conductive plate connected to the collector of the transistor has a low impedance connection to ground via the 2k ohm collector resistor and the conductive plate connected to the inductor has a high impedance connection to ground. The conductive plate with the high impedance connection is more sensitive to unwanted external signals, and therefore circuit operation is improved if it is given additional shielding. In the construction shown in Figure 2, this is conveniently provided by arranging the circuit board carrying the detection circuit 11 so that the conductive plate with the high impedance connection is sandwiched between the conductive plate with the low impedance connection and the circuit board. In this way shielding is provided by the conductive plate with the low impedance connection and

- 11 -

by the ground plane of the circuit board.

As shown in Figure 6, the buffer 25 may be provided by an emitter follower stage, which prevents the input of the frequency divider 27 loading the oscillator circuit 23 excessively.

Returning to Figure 3, the 6 MHz output of the frequency divider 27 is fed via the co-axial cable 19 to a pulse shaper 29 of the signal processing portion 12. The pulse shaper 29 squares the waveform of the signal received over the co-axial cable 19 and provides it to the clock input of a counter 31. The counter 31 is controlled by a microprocessor 35 to count the oscillations of the signal received at its clock input from the detection circuit 11. At the end of a predetermined counting period, for example a 10 ms period, the counter 31 is stopped by the microprocessor 35 and the contents of the counter 31 are loaded in parallel into a shift register 33 under control of the microprocessor 35. When the contents of the counter 31 have been loaded into the shift register 33, the counter 31 is reset and starts counting for the next counting period. The contents of the shift register 33 are then serially loaded into the microprocessor 35.

Therefore, at the end of each counting period the microprocessor 35 receives, via shift register 33, the count value of the counter 31. This count value equals the number of output cycles of the frequency divider 27 of the detection circuit 11 during the counting period. Consequently, this count value gives a measure of the frequency of the signal produced by the oscillator circuit 23.

The presence of a coin between conductive plates 7, 9 will alter the oscillation frequency of the oscillator circuit 23, and consequently it will alter

- 12 -

the count value received by the microprocessor 35. Different coins will tend to alter the oscillation frequency by different amounts, and accordingly the microprocessor 35 can distinguish between coins on the basis of the count value. In order to enable the microprocessor 35 to do this, a look-up table is provided in a memory 37. The look-up table stores coin denomination information with reference to count value.

The degree to which the presence of a coin between the conductive plates 7, 9 alters the oscillation frequency of the oscillator circuit 23 will depend on the thickness and diameter of the coin 1, and possibly on its composition and construction. Accordingly, it is possible for differences in these factors to cancel out and for different coins of different diameters to have substantially the same effect on the oscillation frequency. In order to enable the system to distinguish between such coins, an optical diameter detection system is provided. This comprises an LED 20 and an optical sensor 21 positioned opposite each other on the guide 3 of Figure 1. The LED 20 and optical sensor 21 are spaced at a predetermined height above the floor 4 of the guide 3. A coin of greater diameter than the predetermined height will intercept the light beam from the LED 20 to the optical sensor 21, and accordingly it can be distinguished from a coin of lesser diameter than the predetermined height. The predetermined height is chosen so as to distinguish between pairs of coins which have similar effects on the oscillation frequency of the oscillator circuit 23.

The LED 20 is powered by an optical sensor control circuit 22, which also receives the output signal from the optical sensor 21. The optical sensor control

- 13 -

circuit 22 outputs an optical sensing signal to the microprocessor 35.

5 As shown in Figure 4, the memory 37 comprises three registers, Store A 41, Store B 43 and Difference register 45 and the look-up table 47. Store A 41 contains a reference frequency value of 60000 (the number of oscillation of a 6MHz signal in 10ms counting period).

10 In each count period, the count value from the shift register 33 is loaded into Store B 43. The microprocessor 35 then calculates the difference between the count value in Store B 43 and the reference frequency value in Store A 41. The difference is stored in the Difference register 45.

15 It will be appreciated by those skilled in the art that a coin 1 passing between conductive plates 7, 9 will increase the capacitance provided by the conductive plates, and therefore will reduce the frequency of the signal from the oscillator circuit 23. Therefore, the maximum frequency of the signal will be the 192 MHz frequency output when no coin is present between the conductive plates 7, 9. Thus the number of pulses supplied to the counter 31 in a 10 ms counting period will not exceed 60000, which is well within the counting range of a 16-bit binary counter. Preferably, therefore the counter 31 and the shift register 33 are both 16-bit binary devices, and Store A 41 and Store B 43 are 16-bit registers.

25 A relatively large coin, such as the British £1 and 50p coins, may alter the capacitance of the conductive plates 7, 9 by about 0.7pF, and the corresponding change in the frequency of the oscillator circuit 23 will result in a difference between the value stored in Store A 41 and the value stored in Store B 43 which can be represented as a

30

35

- 14 -

12-bit binary number. Slight instabilities in the oscillator circuit 23 may cause slight variations in the precise 12-bit value, but these can be accommodated by discarding the bottom 4 bits, and storing only the top 8 bits in the Difference register 45. Consequently, the Difference register 45 can be implemented by an 8-bit register.

Figures 5a and 5b illustrate the difference values stored in the Difference register 45 for successive 10ms counting periods as a coin 1 passes between the conductive plates 7, 9. As a coin 1 enters the space between the conductive plates 7, 9 (position 1b in Figure 5a) the difference value stored in the Difference register 45 by the microprocessor 35 in each counting period will increase rapidly to a maximum as shown in Figure 5b. The maximum value is maintained while the coin 1 is fully between the conductive plates 7, 9 (e.g. at position 1a) and then decreases sharply as the coin 1 leaves the conductive plates 7, 9 (at position 1c). When the coin has fully left the conductive plates 7, 9 (at position 1d) the difference value returns substantially to zero. The microprocessor 35 determines the maximum frequency difference and uses it to interrogate the look-up table 47.

The look-up table 47 contains an entry for each possible difference value determined by the microprocessor 35 and corresponding coin validation information. For each possible difference value, the microprocessor 35 receives information enabling it to determine whether the coin is valid or invalid, and also to determine the denomination of a valid coin. The optical sensing signal from the optical sensor control circuit 22 is also input to the look-up table 47. Table 1 gives an example of the contents of the

look-up table 47. Different systems will have different values for each valid coin, and the values given are just an example.

5

TABLE 1

Optical Sensing Difference Value		Signal	
		0	1
10	1 to 44	Invalid	Invalid
	45, 46	5p	Invalid
	47 to 67	Invalid	Invalid
	68 to 70	20p	Invalid
	71 to 84	Invalid	Invalid
15	85 to 89	new 10p	Invalid
	90	new 10p	2p
	91 to 93	Invalid	2p
	94 to 154	Invalid	Invalid
	155 to 158	Invalid	old 10p
20	159 to 193	Invalid	Invalid
	194	£1	Invalid
	195	£1	50p
	196 upwards	Invalid	Invalid

25

Table 1 refers to British coins.

"new 10p" means the style of 10p coin introduced in 1992.

"old 10p" means the style of 10p coin withdrawn in 1993.

30

As can be seen from Table 1, a difference value of 90 can be either the highest acceptable difference value for a new (1992) ten pence piece or the lowest acceptable difference value for a two pence piece. Similarly a difference value of 195 indicates either a

35

- 16 -

one pound coin or a fifty pence coin. The height of the LED 20 and the optical sensor 21 above the floor 4 of the guide 3 is chosen so as to enable both of these ambiguities to be resolved by the optical sensing signal. The output of the optical sensor control circuit 22 will indicate '1' for a two pence coin and a fifty pence coin and '0' for a one pound coin and new ten pence coin.

If the difference value from the look-up table 47 corresponds to a valid coin, the microprocessor 35 indicates to a control circuit 39 that the coin 1 is a valid coin of the denomination indicated by the look-up table 47. In response to this coin validation information the control circuit 39 will control the operation of, for example, the coin operated telephone or vending machine. If the difference value received by the microprocessor 35 corresponds in the look-up table 47 to an invalid coin, the microprocessor 35 will inform the control circuit 39 of this, and the control circuit 39 may e.g. reject the coin 1.

In Figure 3, the control circuit 39 is shown separately from the microprocessor 35. In practice it may be a separate piece of hardware or alternatively its function may be implemented by a program run in the coin validation microprocessor 35.

The circuit of Figure 3 is advantageous because it can be constructed to operate with a power consumption of about 10mA with a 4.5V or 5V supply, especially if the control function of the control circuit 39 is provided by software within the microprocessor 35. This power consumption is sufficiently low that the circuit can act as a coin validator in a payphone powered only by the power available from the telephone line connection. In this way, the need for electric power cells or a mains electricity connection can be

- 17 -

avoided. The most significant power consumption in the circuit is typically in the frequency divider 27. If this is provided by an emitter coupled logic high speed chip such as chip type SP 8797 of Plessey Semiconductors, it will draw about 7mA.

5 In a modification, the microprocessor 35 varies the reference frequency value stored in Store A 41 in response to variations in the count value obtained in the absence of a coin. Such variations may occur, for
10 example, owing to changes in the oscillation frequency of the oscillator circuit 23 with temperature. In this modification a count value is supplied to the microprocessor 35 from 16-bit counter 31 in each counting period and is stored in Store B 43
15 of memory 37. Then the difference is calculated between the values stored in Store A 41 and Store B 43. If the value in Store A 41 is greater than the value in Store B 43, Store A 41 is incremented by 1 and if the difference is the other way round, Store A
20 41 is decremented by 1. Thus, whilst no coin is present in the sensing portion 14 of the coin validator, a value which follows the frequency of the oscillator signal is maintained in Store A 41 of memory 37, and the system is automatically compensated
25 for frequency drift in the oscillator circuit 23.

Depending on the circuit parameters, such drift compensation may be important. For example, in the circuit described above a frequency drift of 0.1% in the oscillator circuit will change the count value in
30 Store B 43 by 60. If the value in Store A 41 is not altered correspondingly, the difference values will also change by 60 and a look-up table in accordance with Table 1 would cease to provide the correct output.

35 The microprocessor 35 can be programmed to

- 18 -

5 identify the presence of a coin 1 from a large
difference value, e.g. a value in excess of 20 in the
case of the Table 1 difference values, and may suspend
its function for updating the contents of Store A 41
10 under these circumstances. This prevents the updating
function from artificially reducing the difference
values generated by the coin. However, if the
microprocessor 35 is programmed to use the largest
15 difference value obtained from a coin, and the
contents of the look-up table 47 are prepared
appropriately, it may not be necessary to turn off the
updating function. In this case, any difference value
which has been significantly reduced by the effect of
20 the updating function will not be the largest value,
and accordingly it will not be used for coin
validation. Since the updating function only changes
the value of Store A 41 by 1 in each counting period,
however great the difference value is, the value of
Store A 41 is only altered slightly by the updating
function during the time a coin passes between the
conductive plates 7, 9, and the updating function will
return Store A 41 to the correct value before the next
coin arrives.

25 As will be appreciated by those skilled in the
art there are other ways in which the circuit can
track frequency drift in the oscillator circuit. For
example, a compensation value may be stored in the
memory 37. The microprocessor may increment or
30 decrement this compensation value instead of the value
in Store A 41. Alternatively, the difference value
between the values in Store A 41 and Store B 43 when
no coin is present may be stored as the compensation
value. The compensation value is used to compensate
35 the difference value in the Difference Register 45 or
the values read from the look-up table 47 when a coin

- 19 -

is present.

In order to enter difference values for valid coins into the look-up table 47, the microprocessor 35 may be set into a training mode. When the
5 microprocessor 35 is in the training mode a number of valid coins may be passed through the coin validator and the microprocessor 35 will store in the look-up table 47 a range of frequency differences and optical sensor pair input values which represent each of the
10 valid coins. The training exercise above will normally be carried out for each coin validation system separately although in some cases it may be possible for training to be carried out centrally and an updated look-up table reproduced and provided to
15 other suitable coin validation systems by exchanging memory chips.

Suitable values for the inductance and the capacitance in the circuit of Figure 6 can provide a resonant frequency of around 200 MHz (e.g. 192 MHz as
20 previously stated).

Provided that the frequency divider 27 can operate at higher input frequencies, the resonant frequency of the oscillator circuit 23 can be increased above 200 MHz by replacing the 3.3pF capacitor in parallel with
25 the conductive plates 7, 9 by a lower value capacitor, or removing it altogether. This will tend to increase the effect of a coin 1 on the resonant frequency. Reducing the value of the inductor will also increase the resonant frequency of the circuit, but the value
30 of the inductor should be maintained large in comparison with the inherent inductance of the circuit wiring and other components to ensure that the circuit operates in a predictable manner. In practice it may be difficult to provide a circuit having a resonant
35 frequency above about 0.5 GHz.

- 20 -

The oscillator circuit 23 can also be arranged to have a resonant frequency lower than 192 MHz. If a much lower frequency is desired, the circuit designer should take account of the consequences of this on the operation of the analysis circuit. If the total circuit capacitance is increased to lower the frequency, the effect of the coin 1 on the frequency will tend to reduce, making it harder to detect the presence of a coin 1 and to distinguish between different coins. If the total circuit capacitance is maintained unchanged, and the resonant frequency is lowered solely by increasing the inductance in the circuit, the effects of the inherent resistance and inherent capacitance of the inductor become more significant, causing unsuitable circuit operation. The analysis circuit of Figure 3 throws away the bottom 4 bits of the difference between the counter value stored in Store B 43 and the reference value stored in Store A 41. These bits are treated as noise due to frequency instability in the oscillator circuit 23. Consequently, the smallest detectable frequency change is one which leads to a change of at least 16 in the value counted by the counter 31, which is a change of about 0.027%. Under these circumstances, it is difficult in practice to provide a usable oscillator circuit with a resonant frequency below 10 MHz, and a resonant frequency above 20 MHz will normally be necessary. Preferably the resonant frequency is at least 50 MHz, more preferably at least 100 MHz.

However, if the oscillator circuit 23 is sufficiently stable, some or all of the lowest 4 bits of the calculated difference can be relied on as a measure of coin characteristics, instead of being ignored as noise. In this case, a smaller percentage

- 21 -

change in oscillator frequency is measurable, provided that the lowest 4 bits of the calculated difference between the values in Store A 41 and Store B 43 are not thrown away before the difference value is stored
5 in the Difference register 45. The ability to measure a smaller percentage frequency change allows the capacitance in the oscillator circuit to be increased. This in turn allows the operating frequency of the oscillator circuit 23 to be reduced. If the circuit
10 of Figure 3 is modified in this way, it may be possible to increase the capacitance in parallel with the conductive plates 7,9 to 10 to 15 pF, and to select the inductance to bring the nominal operating frequency of the circuit to 12 MHz.

15 In this modification, the circuit of Figure 3 is further modified by removing the frequency divider 27. The pulse shaper 29 now receives a signal at 12 MHz instead of 6 MHz. The counter 31 is operated as before, but in 10ms it will overflow once so that its
20 output will be in effect the bottom 16 bits of a 17 bit count. The value in Store A 41, representing the count value for 12 MHz, will nominally be 54464 (the excess of 120000 counts over the overflow value of the counter 31, which is 65536), but it can be updated to
25 track frequency drift as discussed above. The Difference register 45 may store the full 12 bits of the calculated difference, or it may store an 8-bit difference value by choosing the appropriate 8 bits to provide reliable coin identification (e.g. with a
30 particular set of valid coins the top 1 bit may be discarded as unchanging and the bottom 3 bits may be discarded as noise, leaving 8 bits as the difference value). Otherwise, the system works as previously described. This modification allows the frequency
35 divider 27 to be omitted, thereby reducing the overall

- 22 -

power consumption. This eases the power consumption constraints on other circuit components, even if the total power consumption is limited to 5mA at 4.5 or 5V.

5 With this modification, the lowest practical oscillator frequency for the oscillator circuit 23 can be reduced below 10 MHz, to 5MHz or even to 1 MHz.

10 In Figure 7 a circuit diagram is given of an alternative embodiment for the oscillator circuit 23, together with its associated output buffer 25. Some other associated circuitry is also shown.

15 In Figure 7, a resonating circuit is formed by capacitor C1 and inductor L1. The conductive plates 7, 9 are connected across terminals JP1, to provide an additional capacitance in parallel with the capacitor C1. Terminals JP2 are normally shorted together. In this way, an LC oscillator is provided having a natural oscillation frequency which is altered by the presence of a coin between the conductive plates 7, 9 of the coin guide 3.

20 The oscillator is driven by transistors Q2 and Q3. These two transistors have identical dc bias arrangements for their bases, which are connected through respective resistors R7 and R8 to a common node which is in turn connected through matching resistors R5 and R6 to both the positive line voltage V2 and the negative line voltage Vss. The oscillating voltage from the junction between capacitor C1 and inductor L1 is applied to the base of transistor Q3 through dc isolating capacitor C4, and is also applied directly to the collector of Q2. Thus, when the junction between capacitor C1 and inductor L1 is high, transistor Q3 is turned on through C4 and current flows through emitter resistor R13, which is common to both transistor Q3 and transistor Q2. This raises the

25

30

35

- 23 -

emitter potential, tending to turn transistor Q2 off, so that its collector connected to the junction between capacitor C1 and inductor L1 can remain high. When the junction between the capacitor C1 and
5 inductor L1 goes low, transistor Q3 is turned off through capacitor C4, so that it does not provide any current to emitter resistor R13, so that the emitter voltage can fall to the line voltage Vss, and transistor Q2 will tend to turn on owing to its dc
10 bias through resistor R7. Thus, it will tend to conduct current from its collector, pulling down the junction between capacitor C1 and inductor L1. In this manner, the circuit of transistors Q2 and Q3 drives the oscillator.

15 The output signal is taken from the collector of transistor Q3, which in this respect acts as a common emitter coupled amplifying transistor. Inductance L2 is provided so that the collector load for transistor Q3 is partly inductive.

20 The buffer 25 is provided by pnp transistor Q4, which also acts as a common emitter connected amplifier, and provides its output from its collector through dc isolating capacitor C11. Coil L3 provides an inductive collector load for transistor Q4, to
25 magnify the voltage swing at the collector of transistor Q4.

The oscillator circuit of Figure 7 is preferred at present, because it appears to provide better
30 stability of the oscillator frequency with changes of temperature and changes of component values over time as compared with the circuit of Figure 6.

Because of the good stability of the circuit of Figure 7, its component values can be selected to provide an oscillation frequency of 6MHz in the
35 absence of a coin 1. Accordingly, the frequency

- 24 -

divider 27 of Figure 3 is not used. The output from the buffer transistor Q4 is provided through the capacitor C11 to an input of an application specific integrated circuit (ASIC). A diode D1 acts as a dc clamp/level shifter, to ensure that the input to the ASIC does not go lower than about 0.4 volts below line voltage Vss, to ensure that the oscillating voltage provided to the ASIC is within a suitable voltage range. The pulse shaper 29 of Figure 3 is not required, because the inductance L3 ensures that the voltage swing at the input to the ASIC is sufficient to clock the counter 31.

The ASIC contains the counter 31 and shift register 33 of Figure 3. It provides an output for the microprocessor 35 and has input connections to receive signals from the microprocessor. The circuit of Figure 7 is designed for use in a pay telephone, in which the microprocessor 35 is provided on the main circuit board of the telephone, and the ASIC is connected to the microprocessor through a plug connector PL1 for connecting the coin validator circuit board to the main circuit board of the telephone. In this embodiment, the circuit can be constructed to operate with a power consumption of about 5mA at 4.5V or 5V.

The counter 31 in the ASIC receives the output of buffer 25, and the remainder of the analysis circuit operates as described above with reference to Figure 3, except that at least some of the lowest 4 bits of the calculated difference are used to determine the characteristics of the input coin. Preferably, all the bits of the difference are used, and the Difference Register 45 is a 12-bit register storing all bits of the difference value. Accordingly the look-up table 47 contains 12-bit values, between 0 and

4095 (or 000 and FFF in hexadecimal notation). Table 2 gives an example of the contents of the look-up table 47 using 12-bit values.

5

TABLE 2

	Optical Sensing Difference Signal Value	0	1
10	0 - 158	Invalid	Invalid
	159 - 165	5p	Invalid
	166 - 279	20p	Invalid
	280 - 298	Invalid	Invalid
	299 - 354	new 10p	Invalid
15	355 - 397	2p	Invalid
	398 - 765	Invalid	Invalid
	766 - 812	Invalid	50p
	813 - 816	£1	50p
	817 - 891	£1	Invalid
20	892 upwards	Invalid	Invalid

In Table 2 the old 10p coin is not recognised as a valid coin.

25

In this example, the new 10p coin and the 2p coin can be discriminated on the basis of the difference value without confusion, and the optical sensing arrangement is used only to discriminate between the £1 coin and the 50p coin.

30

As an alternative it may be convenient to provide the Difference Register 45 as a 16-bit register, similar to the Store A and Store B registers, even though the difference value is unlikely to require more than 10 or 11 bits.

35

In the circuit of Figure 7 the plug connector PL1

- 26 -

also carries connections by which the microprocessor
35 is able to drive one or two optical detector
devices S1, S2. These are units which comprise a
light emitting diode associated with a photosensitive
5 transistor, arranged so that if a coin is present the
light emitted by the diode will be reflected back to
the unit and detected by the photosensitive
transistor. Line 1 of the plug connector PL1 is a
drive line for the light emitting diodes. When this
10 line goes high, transistor Q1 turns on and current
passes through the light emitting diodes, causing them
to emit light. If a coin is present adjacent the
optical sensor unit, light will be reflected onto the
associated photosensitive transistor, which will
15 conduct, so that potential will be dropped across its
respective collector resistor R9, R10. If no coin is
present the transistor will not conduct and its
collector voltage will remain close to line voltage
V1. The collectors are connected to the plug
20 connector PL1, to provide outputs signals opto 1 and
opto 2 back to the main board of the telephone. Each
optical sensor unit provides an equivalent to the LED
20 and the optical sensor 21.

In practice, if only one optical sensor unit is
25 required, unit S1 may be omitted and the position of
its light emitting diode is shorted by providing a
link between terminals JP3.

The optical sensor unit S2 is used to detect when
a coin enters the coin guide 3, before it reaches the
30 conductive plates 7, 9, so as to prepare the
microprocessor 35 for conducting a coin validation
operation.

The optional optical sensor S1 can be used to
provide a coin height discriminator, to distinguish
35 between large diameter coins and small diameter coins

- 27 -

having the same effect as each other on the capacitance between the conductive plates 7, 9, as described above with reference to the LED 20 and the optical sensor 21. Alternatively it can be used as part of an arrangement to detect attempts fraudulently to remove a coin from the coin guide 3 after insertion. However, it is preferred where possible to choose a width for the coin guide 3 and arrangement for the conductive plates 7, 9 such that there is no confusion between the coins of the coin set with which the validator is intended to be used. Additionally, fraudulent withdrawal of a coin after it has been inserted into the coin guide can alternatively be prevented by mechanical means, such as a flap which is pressed down by the coin as it enters the guide and which rises behind the coin to prevent fraudulent withdrawal.

The circuit of Figure 7 can be constructed on a single circuit board, with the microprocessor 35 on the main control circuit board of the payphone or other apparatus controlled by the coin validator. Conveniently, all of this circuitry can be provided inside the protective box 13, so that connections may be provided by simple wires and the co-axial cable 19 is not required.

If a coin is strongly electrically conductive, its effect on the capacitance between the conductive plates 7,9 will largely be a function of its area (i.e. a function of its diameter) and its thickness. While the coin is between the conductive plates 7, 9, its electrically conductive substance will replace part of the air in the gap between the conductive plates 7, 9, and accordingly it will reduce the effective thickness of the dielectric for part of the capacitor formed by the conductive plates 7, 9. The

- 28 -

part of the capacitor which is affected in this matter will be the part where the coin is present, that is to say, the part defined by projecting the outline of the coin onto the conductive plates 7,9. Therefore the larger the area of the coin is, the greater is the part of the capacitor which is affected. The degree to which the capacitance of the affected part of the capacitor is altered depends on the thickness of the coin. The greater the thickness of the coin is, the more it will reduce the effective thickness of the dielectric of the affected part of the capacitor.

Accordingly, a thin coin of large area will have a small effect over a large part of the capacitor and a thick coin of small area will have a large effect over a small part of the capacitor, and it is possible that the overall effect on the capacitor will be the same in each case. If the width between the conductive plates 7, 9 is altered without changing the size of the conductive plates 7, 9, the effect of the area of a coin on the capacitance is unchanged but the effect of coin width on the capacitance is altered. Therefore, where a pair of coins, one thin and large area and the other thick and small area, have similar effects on the capacitance and are hard to distinguish, use of a different separation between the conductive plates 7, 9 will render them distinguishable. However, a different pair of coins which were previously distinguishable may become hard to distinguish. For any given set of coins, it may be possible to find a convenient separation between the conductive plates 7, 9 which allows all the coins to be distinguished by their effects on the capacitance, or it may be necessary to provide other means such as the LED 20 and optical sensor 21 to distinguish between certain coins. In effect, the other means is

- 29 -

provided so that two detection values are obtained for each coin, and coins which are difficult to distinguish on the basis of one of the detection values are distinguished on the basis of the other detection value. This also improves the performance of the system in detecting invalid coins. Alternative ways of obtaining more than one detection value will now be described.

It is convenient first to discuss a mathematical treatment of the capacitor formed by the coin guide 3, both in the absence of a coin and in the presence of a coin.

The simplest mathematical treatment is to ignore the existence of the walls 2 of the coin guide 3, and treat the capacitor as consisting only of the conductive plates 7,9 and the air gap in the channel between the side walls 2 of the coin guide 3. Since the relative permittivity of air is very close to 1, this leads to the following expression for the capacitance C formed by the conductive plates 7,9.

$$C = E_0 \times A_p / D \quad (1)$$

where E_0 is the dielectric constant, A_p is the area of the conductive plates 7,9, and D is the distance between the conductive plates 7,9.

To provide a more accurate treatment, the side walls 2 of the coin guide 3 should be taken into account. Figure 8 is a schematic view from above of the coin guide 3 together with the conductive plates 7,9, and Figure 9 is an electrical model of the construction of Figure 8. The total capacitance C between the conductive plates 7,9 is now treated as being the overall capacitance of three capacitors C_1, C_2, C_3 in series. C_1 is the capacitance of the air

- 30 -

gap between the side walls 2 of the coin guide 3, the air gap having a width D_1 . C_2 is the capacitance of the side wall 2 next to the first conductive plate 7, the side wall having a thickness D_2 . C_3 is the
 5 capacitance of the side wall 2 of the coin guide 3 next to the second conductive plate 9, the side wall having a thickness D_3 . Accordingly, the values for the three capacitors can be given as follows:

$$10 \quad C_1 = E_0 \times A_p / D_1 \quad (2)$$

$$C_2 = E_0 \times E_r \times A_p / D_2 \quad (3)$$

$$15 \quad C_3 = E_0 \times E_r \times A_p / D_3 \quad (4)$$

where E_r is the dielectric constant for the insulating material (e.g. plastics) of the side walls 2 of the coin guide 3. It is assumed that the side walls 2 are
 20 made of the same material as each other, although it would be possible to make them out of different materials and accordingly the value of E_r might differ between equation (3) and equation (4).

When a coin 1 is passing along the coin guide 3 between the conductive plates 7,9, the capacitance
 25 between the conductive plates 7,9 is altered by the presence of the coin. Figure 10 is a schematic top view of the coin guide 3 with a coin 1 present between the conductive plates 7,9, and Figure 11 is an electrical model of Figure 10.

30 In the electrical model of Figure 11, the part of the area of the plates 7,9 where the coin is absent is treated separately from the area where the coin is present, so that the model provides two capacitive paths in parallel. The left hand path in Figure 11
 35 has an overall capacitance C_A , and is made up of

- 31 -

capacitances C10,C20 and C30 in series, where C10,C20 and C30 correspond to C1,C2 and C3 in Figure 9 but are the capacitances of the air gap and the side walls for the part of the area of the conductive plates 7,9 where the coin is absent. The right hand path in Figure 11 has an overall capacitance CB, and is made up of capacitances C11,C12,C21 and C31 in series. C21 and C31 are the capacitances of the parts of the side walls 2 of the coin guide 3 opposite the coin 1, C12 is the capacitance of the coin 1, and C11 is the capacitance of the reduced-width portion of the air gap next to the coin 1.

In the electrical model of Figure 11, the overall capacitance C between the conductive plates 7,9 is given by

$$C = CA + CB \quad (5)$$

and the component capacitances CA and CB are given by

$$CA = (C10 \times C20 \times C30) / [(C10 \times C20) + (C20 \times C30) + (C10 \times C30)] \quad (6)$$

$$CB = (C11 \times C12 \times C21 \times C31) / [(C11 \times C12 \times C21) + (C11 \times C12 \times C31) + (C11 \times C21 \times C31) + (C12 \times C21 \times C31)] \quad (7)$$

The component capacitances in the model of Figure 11 are given by:

$$C10 = Eo \times (Ap - Ac) / D1 \quad (8)$$

$$C20 = Eo \times Er \times (Ap - Ac) / D2 \quad (9)$$

- 32 -

$$C30 = E_0 \times E_r \times (A_p - A_c) / D_3 \quad (10)$$

$$C11 = E_0 \times A_c / (D1 - D_c) \quad (11)$$

$$5 \quad C12 = E_0 \times E_c \times A_c / D_c \quad (12)$$

$$C21 = E_0 \times E_r \times A_c / D_2 \quad (13)$$

$$10 \quad C31 = E_0 \times E_r \times A_c / D_3 \quad (14)$$

where A_c is the area of the coin, D_c is the thickness of the coin and E_c is the permittivity of the coin.

When the coin 1 is electrically conductive, E_c can be regarded as infinite, and accordingly $C12$ can be regarded as infinite, and can be replaced in Figure 11 by a direct connection. In this case, the value for the overall capacitance C_B of the right hand path in Figure 11 becomes

$$20 \quad C_B = (C11 \times C21 \times C31) / [(C11 \times C21) + (C21 \times C31) + (C11 \times C31)] \quad (15)$$

In order to distinguish between confusable coins, the coin guide 3 can be provided with two or more distinct portions which are different from each other in a relevant parameter (e.g. $D1$), such that a coin 1 has a different effect on the capacitance between the conductive plates 7, 9 when the coin 1 is in one portion as compared with when the coin 1 is in another portion. Coins which would be confusable in one portion (e.g. with one value of $D1$) will normally be distinguishable in a different portion (e.g. with a different value of $D1$).

As can be seen from equation (12) above, when a coin is not electrically conductive it has three

- 33 -

characteristic parameters which can affect the overall capacitance C between the conductive plates 7,9. These are its permittivity ϵ_c , its area A_c and its thickness D_c . Because the coin has three parameters, it is theoretically necessary to provide three regions of the coin guide 3 between the conductive plates 7,9 having different properties to obtain three different measurements, in order to be sure of distinguishing between otherwise confusable coins. In practice, for any given coin set, two separate regions will normally be sufficient to distinguish confusable coins. It is, of course, also possible to provide four or more distinct regions and take four or more separate values of the capacitance to provide additional coin identification values.

There is a considerable choice in the ways in which the coin guide 3 can be altered to provide different regions having different capacitive properties. Of the parameters appearing in equations (8) to (14), ϵ_0 is a physical constant and cannot be altered. The area A_p of the conductive plates 7,9 will be the same for all regions of the coin guide, since the whole area of the plates contribute to the capacitance at all times. However, it is possible to provide different capacitive properties for different regions of the coin guide 3 by providing different values for any of the width of the air gap D_1 , the widths D_2 and D_3 of the side walls 2 of the coin guide 3, and the electrical permittivity ϵ_r of the side walls 2.

Additionally, although it is not possible to construct the coin guide 3 so as to vary the permittivity ϵ_c of the coin or the thickness D_c of the coin, it is possible to vary the effective area A_c of the coin by shaping the conductive plates 7,9 so that

- 34 -

in one region of the coin guide only a part of the area of the coin 1 is between the plates 7,9. If the cut away part of the conductive plates 7,9 is immediately above the level of the floor 4 of the coin guide 3, both the area of the coin 1 which is not
5 between the conductive plates 7,9, and the proportion of the total coin area represented by the area not between the plates 7,9 will be different for different diameter coins.

10 From the above discussion, it will also be apparent that the widths D_1, D_2 and D_3 and the permittivity of the side walls 2 of the coin guide 3 may be varied for only part of the height of the coin guide 3, and different regions of the coin guide 3
15 may be provided by successively changing the height to which the value of a parameter is changed without making further changes to the value itself.

In Figure 12a, the conductive plates 51 are divided into a first portion 53 and a second portion
20 55. In the first portion 53 the conductive plates 51 do not extend down to the bottom of the guide 3, whereas in the second portion 55 the conductive plates 51 do extend down to the bottom of the guide 3. Figure 12a shows a large diameter (large area) thin coin 1' and a small diameter (small area) thick coin 1" passing between the conductive plates 51, and Figure
25 12b shows the difference values which will be stored in difference register 45 for each counting period as the coins 1', 1" pass between the conductive plates 51. The difference values for the large diameter coin 1' are shown by circles in Figure 12b and the difference values for the small diameter coin 1" are
30 shown by crosses in Figure 12b.

The difference values obtained for the coins 1',
35 1" when they are at positions 1'b, 1"b wholly within

- 35 -

the second portion 55 are the same as each other, as shown in Figure 12b. When the small diameter coin 1" is at position 1"a, wholly within the first portion 53, a substantial proportion of the coin area is below the bottom of the conductive plates 51, and its effect on the capacitance of the conductive plates 51 is much reduced. Consequently, the difference value obtained at this time is much lower. When the large diameter coin 1' is at position 1'a, wholly within the first portion 53, the part of the coin area below the bottom of the conductive plates 51 is a small proportion of the total area, and the difference value obtained is not much lower than the difference value obtained when the coin is within the second portion 55. Thus coins 1, 1" which are difficult to distinguish on the basis of their effects when within one of the portions 53, 55 can be distinguished easily on the basis of their effects when within the other one of the portions 53, 55. In Figure 12a, optical sensor pairs 57 and 59 indicate respectively that the coin 1 is fully within the first portion 53 and the second portion 55 of the conductive plates 51.

Another embodiment of the invention as shown in Figure 13a has a first plate 61 which is planar and a second plate 63 which is stepped, to form a capacitor with a first portion 65 and a second portion 67. The plates 61, 63 have a smaller separation in the first portion 65 than in the second portion 67. Consequently the capacitance of the first portion 65 is greater than the capacitance of the second portion 67. As shown in Figure 13b when a coin 1 passes between the first and second plates 61 and 63 the detection circuit 11 will produce two distinct difference values. The effect of changing the separation between the conductive plates is discussed

- 36 -

above. Since different coins which are confusable at one separation can be distinguished at another, the two distinct difference values of Figure 13b allow such coins to be distinguished.

5 A further embodiment of the invention is shown in Figure 14a where a capacitor is formed by two plates 69, the bottom edges of which slope over the distance travelled by a coin 1 between the plates 69 along coin path P. This embodiment operates in substantially the same manner as the embodiment of Figure 12a, except that the difference values increase steadily with position along the plates 69 as shown in Figure 14b, instead of changing in a step fashion between two levels as shown in Figure 12b.

10 In each of Figures 12a, 13a, and 14a, optical sensor pairs 57, 59 are shown which enable the microprocessor 35 to determine when a coin 1 reaches predetermined positions between the conductive plates. However, it may be possible to program the microprocessor to identify the position of a coin 1 from the shape of the curve of successive difference values, in which case the optical sensor pairs 57, 59 may not be needed.

15 Figure 15 is a side view of one of the side walls 2 of a coin guide 3 according to another embodiment, and Figure 16 is an end view of the coin guide 3 for the same embodiment. In the embodiment of Figures 15 and 16 the length of the coin guide 3 can be divided into three sections 101,103,105. In the first section 101, the side wall 2 has a uniform thickness. In the second section 103, the side wall has the same thickness as in the first section 101 over most of its height, but an upper part 107 of the side wall has a reduced thickness. Referring to the mathematical analysis of equations (5) to (15), in the upper part

- 37 -

107 of this section 103 of the side wall 2, the width D2 of the side wall is reduced, and the width D1 of the air gap is increased.

5 For a coin 1 which has a large enough diameter to overlap the reduced-thickness part 107 of the side wall 2 in the second section 103, the effect of the coin 1 on the overall capacitance C of the conductive plates 7,9 will be different when the coin is in the second section 103 of the coin guide 3 from when it is
10 in the first section 101. In cases where two coins are confusable because they have the same effect on the capacitance C of the conductive plates 7,9 while the respective coins were in the first section 101 of the coin guide 3, the effect of the reduced-thickness part 107 of the side wall 2 in the second section 103
15 of the coin guide 3 will tend to enable the coins to be distinguished from one another, provided that at least one the coins has sufficient diameter to overlap the reduced-thickness part 107.

20 In the third section 105 of the coin guide 3, a lower part of the side wall 2 retains the original thickness and upper part 109 of the side wall 2 has the same reduced thickness as the upper part 107 of the side wall 2 in the second section 103. However,
25 in the third section 105 of the coin guide 3, the reduced-thickness part 109 of the side wall 2 extends down lower than the reduced-thickness part 107 of the side wall 2 in the second section 103. Accordingly, the effect of a coin on the overall capacitance C
30 between the conductive plates 7,9 will be different when the coin is in the third section 105 of the coin guide than when the coin 1 is in the first section 101 or the second section 103 of the coin guide, provided that the coin has a diameter sufficient for it to
35 overlap the reduced-thickness part 109 of the side

- 38 -

wall 2.

In particular, it should be noted that a coin has a different effect on the overall capacitance C when it is in the third section 105 from when it is in the second section 103, although the two thicknesses for the side wall 2 are the same as in the second section 103. It is not necessary for the reduced-thickness part 109 of the side wall 2 in the third section 105 of the coin guide to have a different thickness from the reduced-thickness part 107 of the side wall 2 in the second section of the coin guide 103. The illustrated difference in the way in which the full thickness part of the side wall 2 and the reduced-thickness part of the side wall 2 are distributed, with the reduced-thickness part of the side wall 2 being greater in the third section 105 than in the second section 103, is sufficient to provide a difference in the way in which a coin 1 will affect the overall capacitance C between the conductive plates 7,9 when the coin 1 is in the respective section of the coin guide 3.

Figure 17 is a side view of a side wall 2 of the coin guide 3 in a further embodiment of the present invention, and Figure 18 is an end view of the coin guide 3 of Figure 17.

In the embodiment of Figures 17 and 18, a side wall 2 of the coin guide 3 has reduced-thickness portions 107,109 in the second and third sections 103,105 of the coin guide 3, so as to change the effect that a coin 1 has on the overall capacitance C between the conductive plates 7,9, in a similar manner to the arrangement of Figures 15 and 16. However, in the arrangement of Figures 17 and 18 the reduced thickness parts of the side wall 2 are provided below the full thickness portions, rather

- 39 -

than above them as in the arrangement of Figures 15 and 16.

5 With the arrangement of Figures 15 and 16, a small diameter coin which does not reach the level of the reduced-thickness portion 107 of the side wall 2 in the second section 103 of the coin guide 3 will have the same effect on the capacitance between the conductive plates 7,9 while it is in the first section 101 of the coin guide as while it is in the second section 103 of the coin guide 3. Such a coin will only provide a different effect on the capacitance C when it reaches the third section 105 of the coin guide 3 and is able to overlap the reduced-thickness part 109 of the side wall 2 which comes down lower than the reduced thickness section 107 of the side wall 2 in the second section 103 of the coin guide 3. In the arrangement of Figures 17 and 18, the reduced-thickness sections 107,109 of the side wall 2 are present at the bottom of the side wall 2, and extend upwardly by different amounts in the second and third sections 103,105 of the coin guide 3. In this way, even a small diameter coin will have a different effect on the capacitance C between the conductive plates 7,9 in each of the three sections 101,103,105 of the coin guide 3.

Figure 19 is a side view of a side wall 2 of another embodiment of the present invention, and Figure 20 is a top view of the coin guide 3 in the embodiment of Figure 19.

30 In the embodiment of Figures 19 and 20 the thickness of the side wall 2 is reduced in the second section 103 of the coin guide relative to its thickness in the first section 101 of the coin guide, over the entire height of the side wall 2. In the third section 105 of the coin guide 3, the thickness

- 40 -

of the side wall 2 is reduced further, again over the entire height of the side wall 2. Accordingly, the values of the thickness D2 of the side wall and the width D1 of the air gap are different for each of the three sections 101,103,105 of the coin guide 3.

In the embodiments of Figures 15 and 16, Figures 17 and 18 and Figures 19 and 20, the difference between the second section 103 and the third section 105 of the coin guide 3 has involved a change of the same parameter as the difference between the first section 101 and the second section 103 of the coin guide 3. However, this is not essential. Figure 21 is a side view of a side wall 2 in a further embodiment of the present invention, Figure 22 is a top view of the coin guide 3 in the embodiment of Figure 21, and Figure 23 is an end view of the coin guide 3 in the embodiment of Figure 21.

In the embodiment of Figures 21, 22 and 23 the side wall 2 of the coin guide 3 has a different thickness over its entire height in the second section 103 of the coin guide as compared with the first section 101 of the coin guide. In this respect, this embodiment resembles the embodiment of Figures 19 and 20. However, this embodiment resembles the embodiment of Figures 15 and 16 in that the thickness of a lower part of the side wall 2 of the coin guide 3 in the third section 105 of the coin guide 3 is the same as the thickness of the side wall 2 in the second section 103 of the coin guide 3. As a modification to the arrangement of Figures 15 and 16, in the upper part of the third section 105 of the coin guide 3, the side wall 2 is absent completely rather than being present with a reduced thickness. The conductive plate 7 is also absent completely in the upper part of the third section 105 of the coin guide 3 in this embodiment.

- 41 -

Where the conductive plates 7,9 are provided by printing a conductive ink on the side walls 2 of the coin guide 3, it is not practical to provide a part of the conductive plate 7 where there is no side wall 2. However, it would be possible to provide the conductive plate 7 even where there is no side wall 2 in arrangements where the conductive plate 7 is provided by a separate conductive plate bonded to the side wall 2.

The absence of the conductive plate 7 from the upper part of the third section 105 of the coin guide 3 means that the effective area A_c of a coin 1 is different in the third section 105 of the coin guide 3 from in the second section 103 of the coin guide 3. In an arrangement corresponding to the embodiment of Figures 21, 22 and 23, but in which the conductive plate 7 extended for the full height of the coin guide 3 in the third section 105, and only the side wall 2 was missing in the upper section, the effective area A_c of the coin 1 would not be different between the second section 103 and the third section 105 of the coin guide 3, but instead the effective values of the width D_1 of the air gap and the thickness D_2 of the side wall 2 would be different between these sections of the coin guide 3.

Figure 24 is a side view of a side wall 2 in a another embodiment of the present invention, and Figure 25 is an end view of the coin guide 3 in the embodiment of Figure 24.

In the embodiment of Figures 24 and 25, the physical dimensions of the side wall 2 are not altered between the sections 101,103,105 of the coin guide 3. Instead, the side wall 2 is made of a different dielectric material in each of the three sections. The values of the relative permittivity of plastics

- 42 -

materials suitable for use in the coin guide 3 will typically be between 2 and 6. In the embodiment of Figures 14 and 15, the different materials are chosen to have different relative permittivities, so that the value E_r will be different in each of the three sections 101,103,105 of the coin guide 3. In this way, the effect of the coin 1 on the overall capacitance C between the conductive plates 7,9 will be different for each of the sections 101,103,105.

The embodiments of Figures 12 to 25 provide some examples of the ways in which changes can be made in the effective values of D_1, D_2, E_r and A_c , so that coins which cannot be distinguished on their effect while they are in one section of the coin guide 3 can be distinguished by their effect when they are in another section of the coin guide 3.

A coin validator will normally be set up for use with a particular predetermined coin set. Substantially the same coin validator can be manufactured for use with a variety of coin sets, and the particular coin set for which it is to be used is determined by the difference values stored in the look up table, by which the effect of a coin on the capacitance between the conductive plates 7,9 is translated into a coin recognition or rejection. The width of the air gap D_1 in a coin guide 3 must be sufficient to permit the thickest coin of the coin set to pass along the guide 3 without obstruction. Where a validator is made for use with a variety of possible sets of coins, the width of the thickest coin in one coin set may be different from the width of the thickest coin in another coin set. Therefore, the coin guide may have a width D_1 of the air gap which is larger than is necessary for use with some of the coin sets.

- 43 -

5 If the width D_1 of the air gap is reduced, the effect of the presence of a coin 1 on the capacitance between the conductive plates 7,9 will tend to be increased, making it easier for the validator to
10 detect the presence of a coin. The increased values in the change of the capacitance C also tends to make it easier to distinguish between the different coins of the coin set. Thus, it is in general desirable to minimise the width of the air gap D_1 , to the extent
15 that this is possible while still permitting the thickest coin of the coin set to pass down the coin guide 3. The effect of reducing the width of the air gap D_1 remains even if the thickness D_2 of the side walls are increased by a corresponding amount, because
the relative permittivity ϵ_r of the material of the side walls 2 is greater than 1 so that the overall capacitance C is increased by filling part of the air gap with the material of the side wall 2.

20 Where a validator has been made with a relatively wide air gap D_1 in the coin guide 3, but it is to be used with a coin set in which the thickest coin is substantially thinner than the width of the air gap D_1 , the validator can be modified as shown in Figures 26 and 27. Figure 26 is a side view of an insert 111
25 of dielectric material, which may be attached to the inner side of a side wall 2 of the coin guide 3, as shown in Figure 27. In this way, part of the width of the air gap D_1 is filled with dielectric material. This arrangement allows the manufacturing convenience
30 of making one standard coin guide 3 for a range of validators. The width of the air gap D_1 can then be adapted at low cost by attaching an appropriate insert 111 to take into account the thickness of the thickest coin in the coin set with which the validator is to be
35 used.

- 44 -

5 Additionally, the feature of an insert 111 can be used as a means of providing the difference between the first section 101, second section 103 and third section 105 of the coin guide 3 as discussed with reference to Figures 15 to 25. For example, Figure 28 shows a side view of an insert 111 having a stepped height, so that when it is attached to one of the side walls 2 an arrangement is obtained which is equivalent to the embodiment of Figures 15 and 16. Figure 29 shows a top view of an insert 111 having a stepped thickness, so that when such an insert is attached to a side wall 2 an arrangement is provided corresponding to the embodiment of Figures 19 and 20. Figure 30 shows an insert 111 in which different sections are made of materials having different relative permittivities, so that when such an insert is attached to a side wall 2, an arrangement is provided corresponding to the embodiment of Figures 24 and 25. This allows the manufacturing convenience of making standard uniform coin guides 3, and separately manufacturing a range of inserts to define the different sections 101,103,105 of the coin guide 3.

10
15
20
25
30
35 Although it has not been shown in Figures 15 to 30, the coin guide 3 will normally be set at a sideways tilt so that the coin always rests against one of the side walls 2 and does not contact the other, as shown in Figure 2. Where the different sections of the coin guide are defined by differences in the physical dimensions of a side wall 2, and particularly in cases where the thickness of a side wall 2 changes, it is normally preferable for the side wall having the physical variations to be the side wall against which the coin 1 does not rest, so that the variations in the physical dimension of the side wall 2 do not interfere with the smooth rolling of

- 45 -

the coin 1 along the coin guide 3.

5 In a further embodiment of the invention as shown in Figure 31 and Figure 32a an inductive sensor 71 is situated on the inner wall of the coin guide 3 opposite the wall along which a coin 1 moves, in conjunction with capacitive plates 73 and 75. The inductive sensor 71 is a plate carrying an inductor coil connected in series with the inductance of the oscillator circuit 23 so that as coin 1 moves between 10 the plates 71, 73 and 75 along path P both the capacitance and the inductance of the oscillator circuit 23 are affected and therefore the resonant frequency of the oscillator circuit 23 is changed, as shown in Figure 32b. Provided that the coins 1 are 15 electrically conductive, the composition of the coin has relatively little effect on the capacitance of the conductive plates. However, the inductive sensor 71 will be affected by the magnetic properties of the coin, and accordingly it enables the system to 20 distinguish between a non-magnetic coin and a ferro-magnetic mild steel blank of the same diameter and thickness.

Figure 33 shows a modification of the oscillator circuit 23 of Figure 6, for use with the above 25 embodiment, where the coil of the inductive sensor 71 is represented by inductance L1 is connected in series with the inductance L2. The coin path P is shown with dotted arrows moving between the capacitive plates 73 and 75 and past the inductive sensor 71.

30 The circuit of Figure 7 can be modified in a similar manner for use with the inductive sensor 71 (which in this case may be a wound coil instead of a plate, in view of the relatively low 6 MHz operating frequency). In this case, the terminals JP2 are not 35 shorted together. Instead the coil of the inductive

- 46 -

sensor 71 is connected between the terminals JP2, in series with inductance L1.

5 The inductive sensor 71 can be provided at the same position along the guide 3 as the conductive plates 73, 75 so that a single composite difference value is obtained for each coin. Alternatively, the inductive sensor 71 may overlap only part of the conductive plates 73, 75 or not overlap them at all, so that each coin produces two distinct difference values.

10 Since the inductive sensor 71 is used to distinguish between ferro-magnetic and non-magnetic coins, and is not used for detailed size detection, it is not necessary to provide an expensive wound coil or a ferrite core. For the same reason, it does not matter that at the high operating frequencies discussed above for the oscillator circuit 23, the magnetic field of the inductive sensor 71 will typically not penetrate a coin. Under these circumstances, the effect of a coin on the inductive sensor 71 will largely be due to its effect of concentrating or dispersing magnetic flux, not due to eddy currents in the coin, and this effect will be different for ferro-magnetic and non-magnetic coins.

20 Figure 34 shows an alternative circuit to that in Figure 3 where the output of the oscillator 77 is fed into a frequency divider 79 via a buffer 81, similarly to the circuit of Figure 3, but the output of the frequency divider 79 is fed via a co-axial cable 83 to a mixer 85 instead of to the pulse shaper 29 of Figure 3. In the mixer 85 the signal is mixed with a reference signal of known frequency produced by a reference oscillator 87. The resulting signal has a lowest frequency component which represents the difference between the reference frequency and the

25
30
35

- 47 -

detection signal frequency from the frequency divider 79. This mixed frequency signal is passed to a low-pass filter 89 to obtain the frequency difference signal which is passed to a pulse shaper 91, then to a
5 frequency divider 93 and then to a microprocessor 95 where the frequency difference is compared to the range of frequency differences for known valid coins which are stored in memory 97. If the frequency difference matches that of a known valid coin, the
10 microprocessor 95 indicates to the control circuit 99 that the coin is valid and of a particular denomination and if the frequency difference is not matched against that of known valid coin, the microprocessor 95 sends a signal to the control
15 circuit 99 to indicate that the coin is invalid and should be rejected.

The microprocessor 95 determines the difference frequency by counting pulses received from the frequency divider 93 in a preset period. The
20 frequency divider 93 is used to scale the difference frequency so that the number of pulses counted by the microprocessor does not overflow its internal registers.

This circuit may be compensated for drift in the rest frequency of the oscillator 77 by making a
25 corresponding change to the frequency of the reference oscillator 87. This is the equivalent in this embodiment to varying the reference value in Store A 41 in the embodiment of Figures 3 and 4.

30 As discussed above, the frequency divider 79 is not necessary if the oscillator circuit 77 operates at a sufficiently low frequency, such as the 6MHz proposed for the circuit of Figure 7. Additionally, the co-axial cable 83 is not needed if the components
35 are housed in a common protective box 13.

- 48 -

5 As can be seen, the illustrated embodiments provide a coin validator of simple construction, and in which the structure of the validator does not wholly determine which coins can be detected and accepted. Modification of the validator to alter which coins are acceptable can be carried out easily since it will often only be necessary to change the contents of the look-up table.

- 49 -

CLAIMS:

1. Apparatus for determining whether an input coin is acceptable and for distinguishing between a plurality of acceptable coins, comprising:

5

capacitor means (7, 9);

10

guide means (3) to guide an input coin (1) along a coin path past the capacitor means thereby to affect its capacitance while the coin is in a first portion of the coin path;

oscillator means (23) for providing an oscillating output signal the frequency of which is affected by the capacitance of the capacitor means;

15

value obtaining means (31, 33, 43) for receiving the oscillating output signal and obtaining a first value representing the frequency of the oscillating output signal while an input coin is in the first portion of the coin path; and

20

decision means (35, 47) for making a decision on the basis of the first value whether the input coin is acceptable and, if so, which of a plurality of acceptable coins it is,

characterised in that

25

the decision means (35, 47) uses a second value to distinguish between different input coins which result in the same first value, the second value representing a parameter of the input coin other than its effect on the capacitance of the capacitor means while it is in the first portion of the coin path.

30

2. Apparatus according to claim 1 which comprises further means (20, 21; 71) for obtaining said second value, which represents a parameter of the input coin other than its effect on the capacitance of the capacitor means (7, 9).

35

- 50 -

3. Apparatus according to claim 2 in which said further means comprises a coin diameter detector (20, 21).
- 5 4. Apparatus according to claim 3 in which the coin diameter detector (20, 21) comprises an optical sensor.
- 10 5. Apparatus according to claim 3 or claim 4 in which the coin diameter detector (20, 21) detects whether the diameter of an input coin is more or less than a threshold diameter.
- 15 6. Apparatus according to claim 2 in which said further means comprises an inductor (71), the inductance of which is affected by the input coin.
- 20 7. Apparatus according to claim 6 in which the frequency of the oscillating output signal is affected by the inductance of the inductor (71), the input coin (1) affects the inductance of the inductor while the coin is in a second portion of the coin path, and the second value represents the frequency of the oscillating output signal while the input coin is in
- 25 the second portion of the coin path.
8. Apparatus according to claim 7 in which the second value provides a measurement of whether the input coin is ferromagnetic or paramagnetic.
- 30 9. Apparatus according to claim 1 in which the capacitor means (7, 9) and the guide means (3) are arranged so that an input coin (1) affects the capacitance of the capacitor means (7, 9) while the
- 35 coin is in a second portion of the coin path but one

- 51 -

or more of the physical parameters of the capacitor means, which determine the extent of the effect of the coin on the capacitance of the capacitor means, is different at the second portion of the coin path from the first, and the value obtaining means (31, 33, 43) obtains the second value which represents the frequency of the oscillating output signal while the input coin is in the second portion of the coin path.

5
10

10. Apparatus according to claim 8 in which one or more of said physical parameters varies gradually from the first portion to the second portion of the coin path.

15

11. Apparatus according to claim 9 in which one or more of said physical parameters varies substantially as a step function from the first portion to the second portion of the coin path.

20

12. Apparatus according to any one of claims 9 to 11 in which the said one or more physical parameters comprises the height of an edge of a capacitor plate (7, 9; 51; 69) of the capacitor means above a floor (4) of the guide means (3), which affects the amount of overlap between the area of the input coin (1) and the capacitor plate (7, 9).

25

13. Apparatus according to any one of claims 9 to 12 in which the said one or more physical parameters comprises the spacing apart of capacitor plates (61, 63) of the capacitor means.

30

- 52 -

14. Apparatus according to any one of claims 9 to 13
in which the said one or more physical parameters
comprises the effective thickness (D2) of a piece of
dielectric material between capacitor plates of the
5 capacitor means.

15. Apparatus according to any one claims 9 to 14 in
which the said one or more physical parameters
comprises the effective dielectric constant (relative
10 permittivity) of a piece of dielectric material
between capacitor plates of the capacitor means.

16. Apparatus according to any one of claims 9 to 15
in which the said one or more physical parameters
15 comprises the effective width (D1) of an air gap
through which the input coin passes between capacitor
plates of the capacitor means.

17. Apparatus according to any one of claims 13 to 16
20 in which the value of one of said physical parameters
varies as a function of height above a floor of the
coin guide, at one of said portions of the coin
path.

25 18. Apparatus according to claim 17 in which the
value of one of said physical parameters is the same
for both said portions of the coin guide over a first
height range above the floor of the coin guide but is
different for the first and second portions over a
30 second height range above the floor of the coin guide,
so that the first and second portions have different
effective values for the physical parameter
concerned.

- 53 -

19. Apparatus according to any one claims 9 to 18 in which a member (11) fixed to a wall (2) of the guide means (3) provides a difference in one or more said physical parameters between the first portion and the second portion of the coin path.

20. Apparatus according to any one of the preceding claims comprising compensation means for monitoring the rest frequency of the oscillating output signal in the absence of an input coin and compensating the decision means for changes in the rest frequency over time.

21. Apparatus for determining whether an input coin is acceptable and for distinguishing between a plurality of acceptable coins, comprising:

capacitor means (7,9);

guide means (3) to guide an input coin (1) along a coin path past the capacitor means thereby to affect its capacitance;

oscillator means (23) for providing an oscillating output signal the frequency of which is affected by the capacitance of the capacitor means; and

decision means (31, 33, 35, 37) for receiving the oscillating output signal and making a decision on the basis of the frequency thereof whether the input coin is acceptable and, if so, which of a plurality of acceptable coins it is,

characterised in that

the decision means comprises compensation means for monitoring the rest frequency of the oscillating output signal in the absence of an input coin and compensating the decision means for changes in the rest frequency over time.

- 54 -

- 5 22. Apparatus according to claim 21 in which the decision means derives a difference value representing the difference between the frequency of the oscillating output signal when an input coin is present and a reference frequency, and makes the said decision on the basis of the difference value and a pre-stored correlation of possible difference values and input coin identification data.
- 10 23. Apparatus according to claim 22 in which the reference frequency is substantially equal to the rest frequency of the oscillating output signal when no coin is input.
- 15 24. Apparatus according to claim 22 or claim 23 in which the compensation means updates the reference frequency to take account of changes over time in the rest frequency of the oscillating output signal.
- 20 25. Apparatus according to any one of claims 22 to 24 in which the decision means derives the difference value by comparing a value representing the frequency of the oscillating output signal with a pre-stored value representing the reference frequency.
- 25 26. Apparatus according to claim 25 when dependent on claim 24 in which the compensation means updates the reference frequency by updating the pre-stored value.
- 30 27. Apparatus according to claim 26 in which the compensation means updates the reference frequency by comparing the pre-stored value with a value representing the rest frequency of the oscillating

- 55 -

output signal, and updating the pre-stored value in response to the result of the comparison.

5 28. Apparatus according to any one of claims 21 to 27
in which the capacitor means (7, 9; 51; 61, 63; 69)
has different coin area/width trade-off groups at
different positions along the coin path, a coin
area/width trade-off group being a group of possible
10 coin dimensions the members of which have different
coin widths and different coin areas but the same
effect on the capacitance of the capacitor means when
a coin having the coin dimensions is at the position
along the coin path.

15 29. Apparatus according to claim 28 in which the said
different coin area/width trade-off groups are
provided by providing different separations between
conductive plates (61, 63) of the capacitor means at
different positions along the coin path.

20 30. Apparatus according to claim 28 in which the said
different coin area/width trade-off groups are
provided by providing conductive plates (51, 69) of
the capacitor means with different extents or
25 positions in a direction transverse to the coin path
at different positions along the coin path.

30 31. Apparatus according to claim 28 in which the said
different coin area/width trade-off groups are
provided by providing different widths of dielectric
material and/or different widths of an air gap between
the conductive plates (7, 9) at different positions
along the coin path.

- 56 -

32. Apparatus according to any one of claims 21 to 31 in which the coin path passes between conductive plates (7, 9) of the capacitor means.
- 5 33. Apparatus according to any one of claims 21 to 32 further comprising inductor means (71), the guide means (3) guiding an input coin (1) past the inductor means (71) and the frequency of the oscillating output signal being affected by the inductance of the
10 inductor means.
34. Apparatus according to any one of claims 21 to 33 further comprising further means (20, 21) for distinguishing between input coins on the basis of a
15 physical dimension, the decision means making the said decision also on the basis of the output of the further means at least in some circumstances.
35. Apparatus according to claim 34 in which the
20 physical dimension comprises coin diameter.
36. Apparatus according to any one of the preceding claims in which the oscillator means comprises a capacitance/inductance tuned oscillator.
25
37. Apparatus for determining whether an input coin is acceptable and for distinguishing between a plurality of acceptable coins, comprising:
30 capacitor means (7, 9);
guide means (3) to guide an input coin (1) along a coin path past the capacitor means thereby to affect its capacitance; and
determination means for responding to the effect of an input coin on the capacitance of the capacitor
35 means to determine whether the coin is unacceptable or

- 57 -

which of a plurality of acceptable coins it is,
characterised in that

5 a piece of material (111), separate from the
material of the guide means (3), is fixed to the guide
means where an input coin (1) passes the capacitor
means, narrowing the width of the coin path compared
with its width if the piece of material (111) was not
present.

10 38. Apparatus according to claim 37 in which the
piece of material (111) affects the capacitance of the
capacitor means and provides a difference in the
effect of an input coin on the capacitance of the
capacitor means (7, 9) at different positions along
15 the coin path.

39. Apparatus according to claim 38 in which the
piece of material (111) is non-uniform in at least one
of: its height; its thickness; and its composition, in
20 the direction along the coin path.

40. Apparatus for determining whether an input coin
is acceptable and for distinguishing between a
plurality of acceptable coins, comprising:

25 capacitor means (7, 9);
guide means (3) to guide an input coin (1) along
a coin path past the capacitor means thereby to affect
its capacitance;

30 oscillator means (23) for providing an
oscillating output signal the frequency of which is
affected by the capacitance of the capacitor means;
and

35 decision means (31, 33, 35, 37) for receiving the
oscillating output signal and making a decision on the
basis of the frequency thereof whether the input coin

- 58 -

is acceptable and, if so, which of a plurality of acceptable coins it is,

characterised in that

5 the apparatus further comprises inductor means (71), the guide means (3) guiding an input coin (1) past the inductor means (71) thereby to affect its inductance depending on the magnetic properties of the input coin (1), and the frequency of the oscillating output signal being affected by the inductance of the inductor means (71), thereby enabling the decision means (31, 33, 35, 37) to be responsive to the magnetic properties of the input coin e.g. whether it is ferromagnetic or paramagnetic.

15 41. Apparatus according to claim 40 in which the inductor means (71) and the capacitor means (7, 9) are present at a common position along the coin path, and the decision means (31, 33, 35, 37) makes the decision on the basis of the frequency of the oscillating output signal at a time when both the capacitance of the capacitor means (7, 9) and the inductance of the inductor means (71) are affected by an input coin (1).

25 42. Apparatus according to claim 40 in which the inductor means (71) and the capacitor means (7, 9) are present at first and second positions with no overlap or only a partial overlap, and the decision means (31, 33, 35, 37) makes the decision on the basis of: (i) the frequency of the oscillating output signal at a time when only one of the capacitance of the capacitor means (7, 9) and the inductance of the inductor means (71) is affected by an input coin (1); and (ii) the frequency of the oscillating output signal at a time when only the other of the capacitance of the

30

35

- 59 -

capacitor means (7, 9) and the inductance of the inductor means (71) is affected by the input coin (1) or when both of them are affected by the input coin (1).

5

43. Apparatus for determining whether an input coin is acceptable and for distinguishing between a plurality of acceptable coins, comprising:

capacitor means (7, 9);

10

guide means (3) to guide an input coin (1) along a coin path past the capacitor means thereby to affect its capacitance;

oscillator means (23) for providing an oscillating output signal the frequency of which is affected by the capacitance of the capacitor means; and

15

decision means (31, 33, 35, 37) for receiving the oscillating output signal and making a decision on the basis of the frequency thereof whether the input coin is acceptable and, if so, which of a plurality of acceptable coins it is.

20

44. A method of determining whether an input coin is acceptable and for distinguishing between a plurality of acceptable coins, in which an input coin is guided along a coin path past capacitor means so as to affect the capacitance thereof while at a first position along the coin path, an oscillator means generates an oscillating output signal the frequency of which is affected by the capacitance of the capacitor means, and the input coin is rejected or it is decided which of a plurality of acceptable coins the input coin is on the basis of the frequency of the oscillating output signal while the input coin is at a first position along the coin path,

30

35

- 60 -

characterised in that

5 the rejection of the coin, or decision which of a plurality of acceptable coins the input coin is, also is made on the basis of a value representing a parameter of the input coin other than its effect on the capacitance of the capacitor means (7, 9) at the first position along the coin path.

10 45. A method according to claim 44 in which the said value is the frequency of the oscillating output signal when the coin is at a second position along the coin path at which the coin also affects the capacitance of the capacitor means, but one or more physical parameters of the capacitor means, which
15 determine the extent to which the coin affects the capacitance of the capacitor means, is different at the second position from the first position.

20 46. A method according to claim 44 in which the said value represents a parameter of the input coin other than its effect on the capacitance of the capacitor means (7, 9).

25 47. A method of determining whether an input coin is acceptable and for distinguishing between a plurality of acceptable coins, in which an input coin is guided past capacitor means so as to affect the capacitance thereof, an oscillator means generates an oscillating output signal the frequency of which is affected by
30 the capacitance of the capacitor means, and the input coin is rejected or it is decided which of a plurality of acceptable coins the input coin is on the basis of the frequency of the oscillating output signal,
characterised in that

35 the rest frequency of the oscillating output

- 61 -

signal in the absence of a coin is monitored so as to compensate the rejection or decision step for changes in the rest frequency over time.

5 48. A method of determining whether an input coin is acceptable and for distinguishing between a plurality of acceptable coins, in which an input coin is guided past capacitor means so as to affect the capacitance thereof, an oscillator means generates an oscillating
10 output signal the frequency of which is affected by the capacitance of the capacitor means, and the input coin is rejected or it is decided which of a plurality of acceptable coins the input coin is on the basis of the frequency of the oscillating output signal,
15 characterised in that

the coin is guided past inductor means so as to affect the inductance thereof depending on the coin's magnetic properties, and the frequency of the oscillating output signal is affected by the
20 inductance of the inductor means, whereby the magnetic properties of the coin are taken into account in rejecting the input coin or deciding which of a plurality of acceptable coins the input coin is.

25 49. A method of determining whether an input coin is acceptable and for distinguishing between a plurality of acceptable coins, in which an input coin is guided past capacitor means so as to affect the capacitance thereof, an oscillator means generates an oscillating
30 output signal the frequency of which is affected by the capacitance of the capacitor means, and the input coin is rejected or it is decided which of a plurality of acceptable coins the input coin is on the basis of the frequency of the oscillating output signal.

35

1/11
FIG. 1

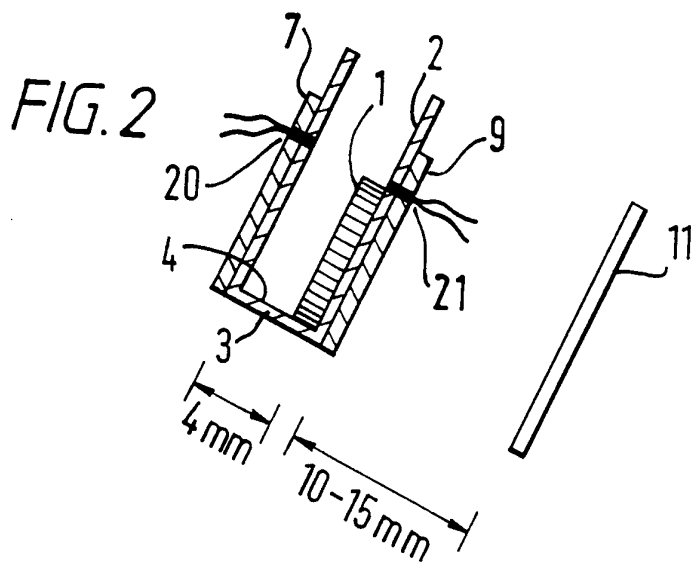
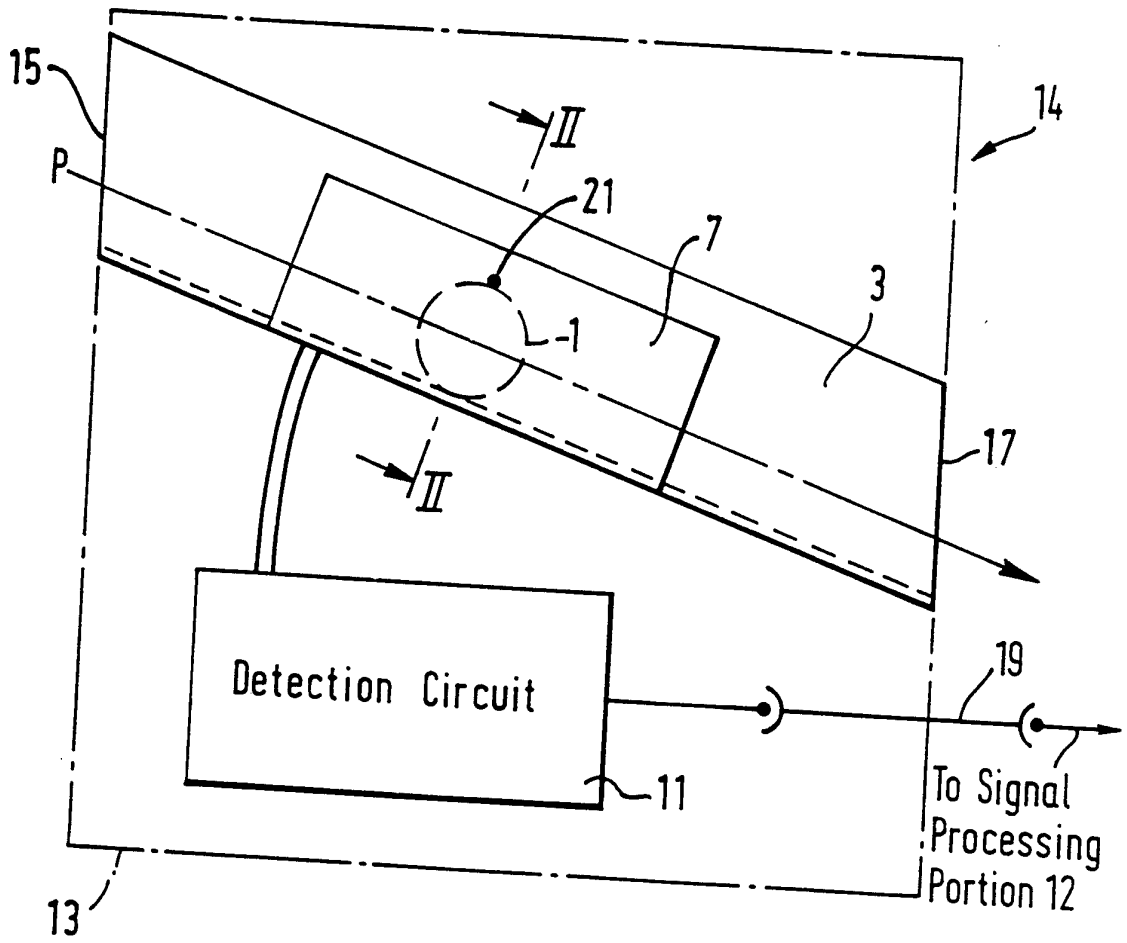

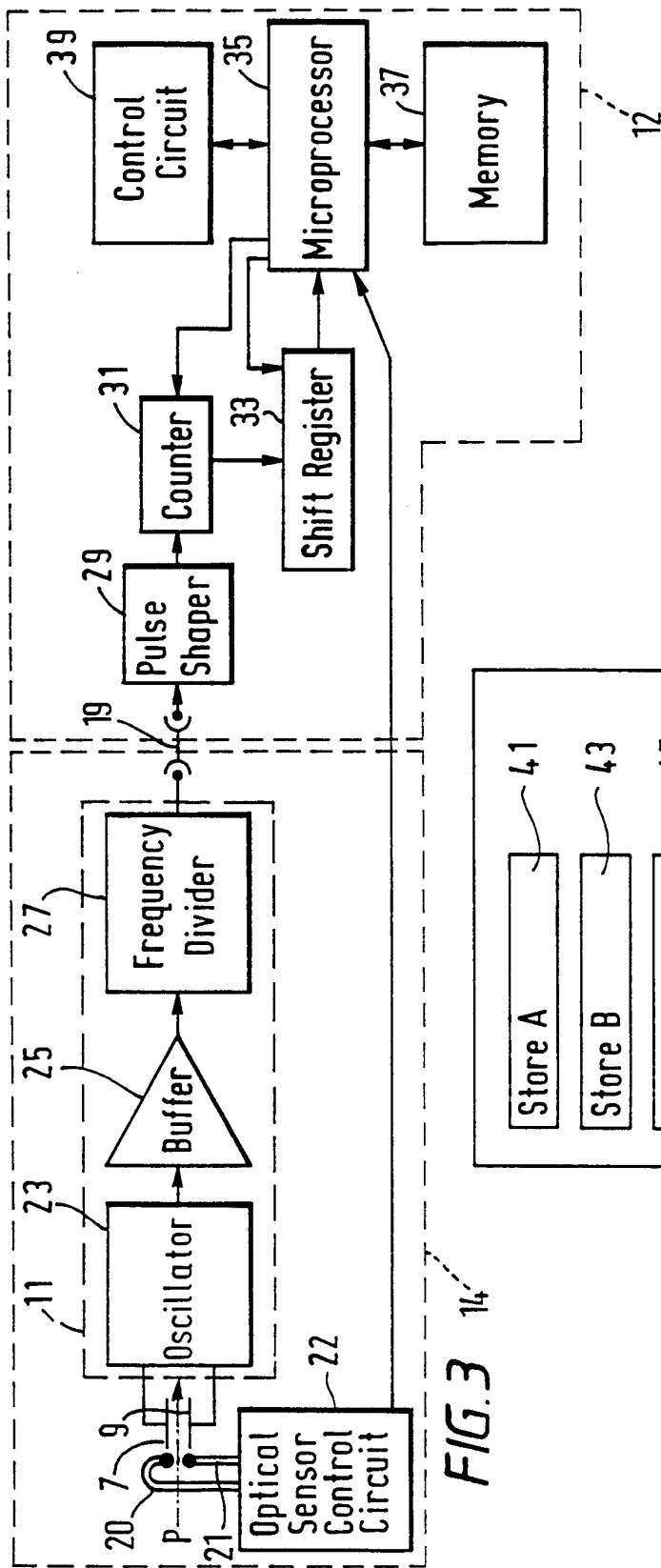

FIG. 3 14

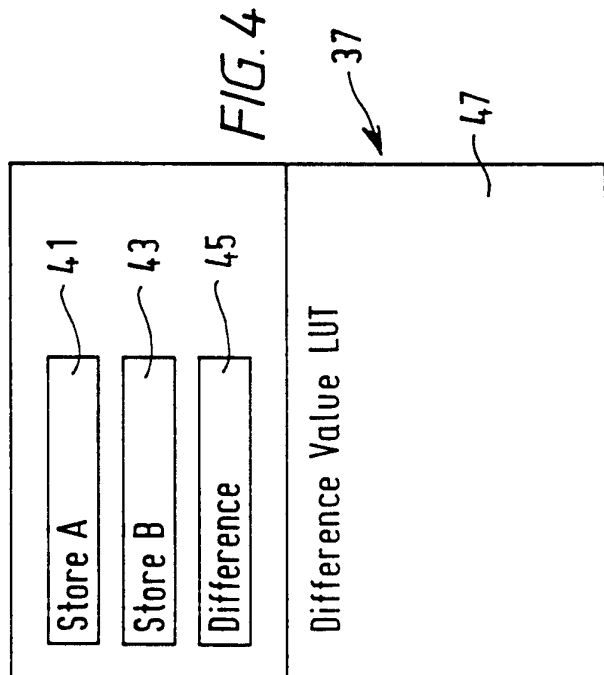

FIG. 4

37

47

3/11

FIG. 5a

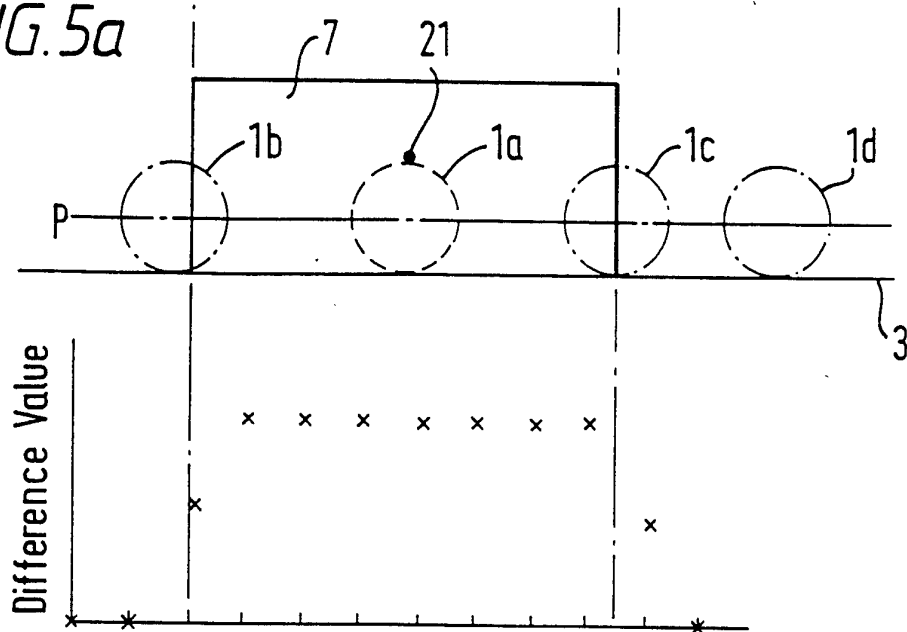
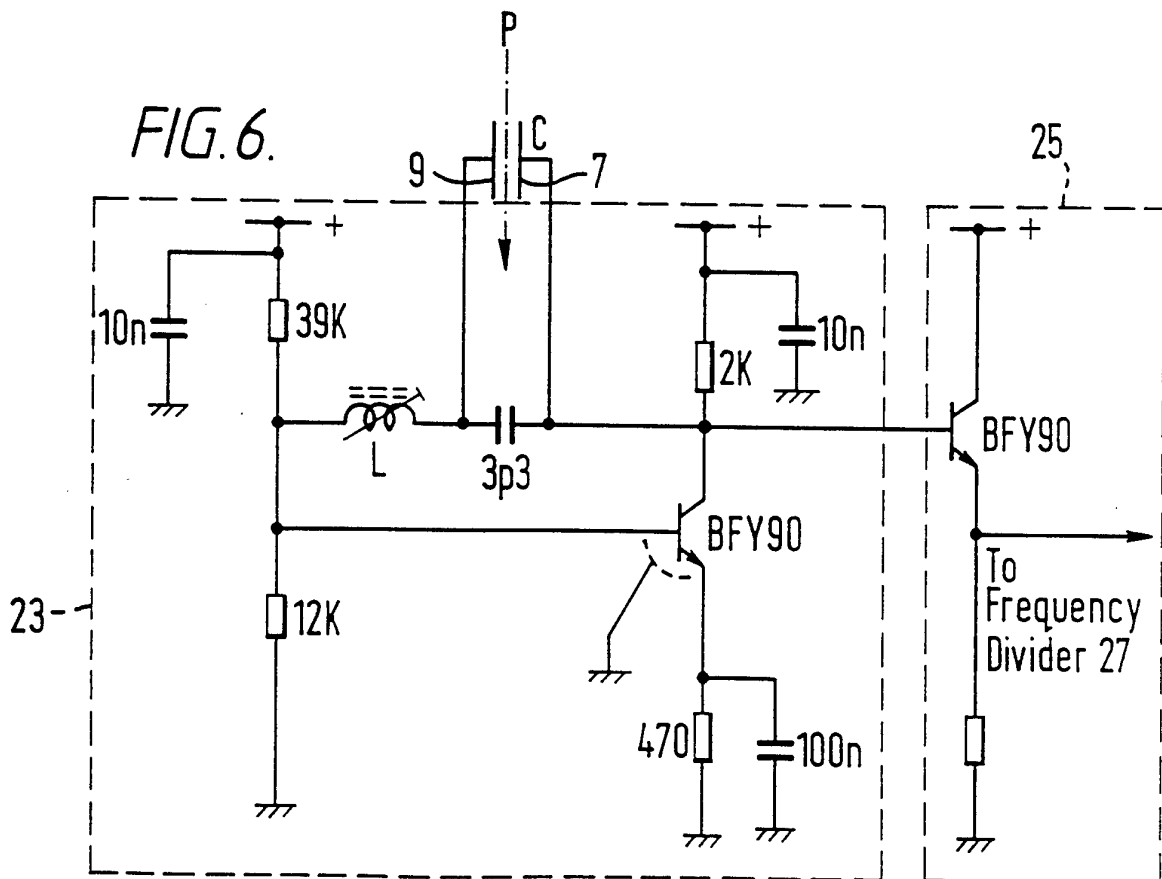

FIG. 5b

10ms Counting periods.

FIG. 6.



4/11

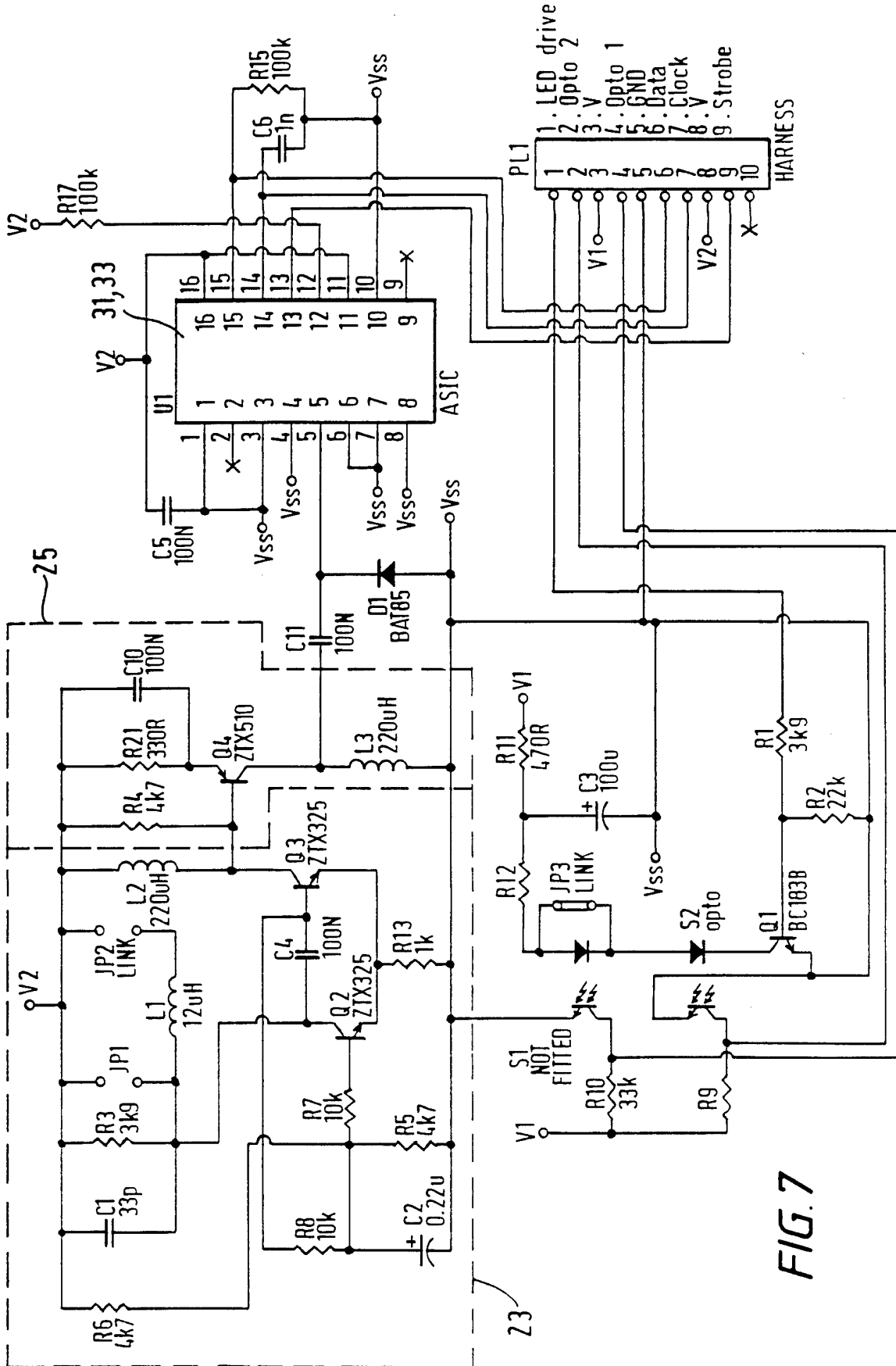

FIG. 7

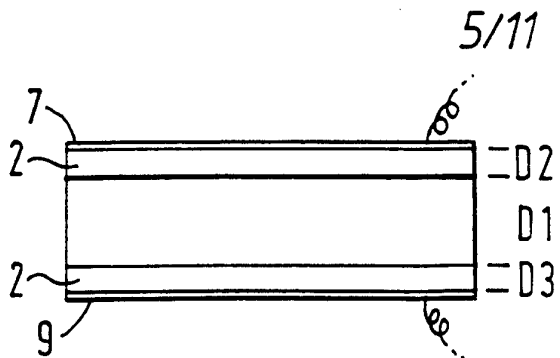

FIG. 8

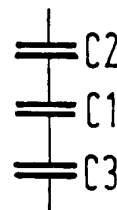

FIG. 9

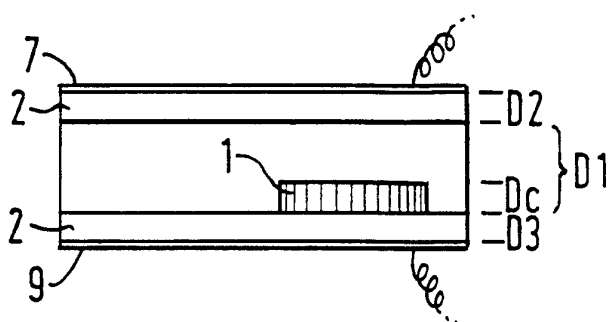

FIG. 10

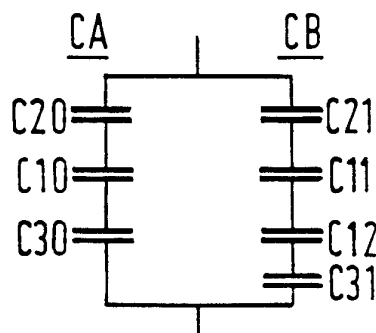

FIG. 11

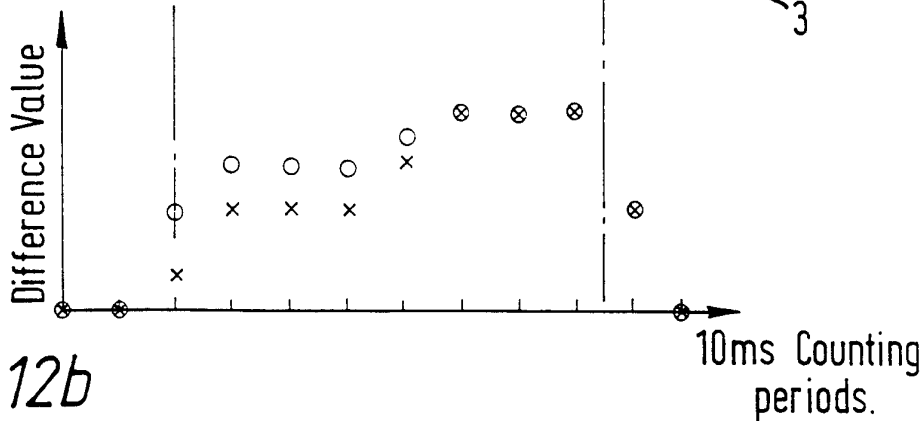
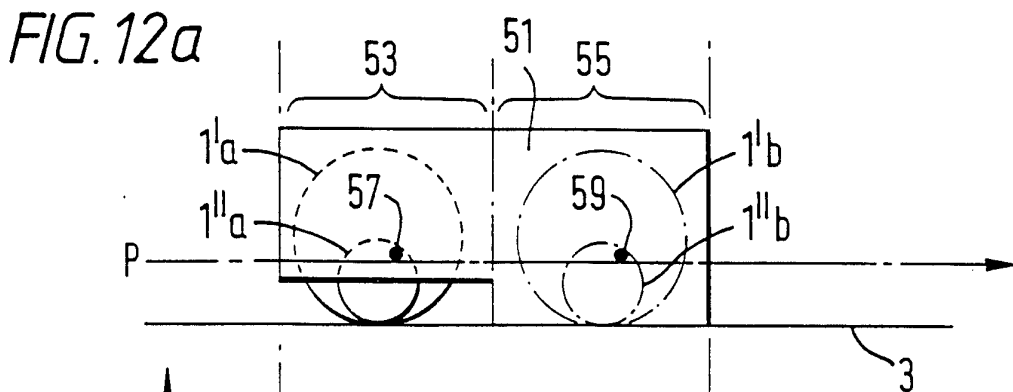

FIG. 12b

6/11

FIG. 13a

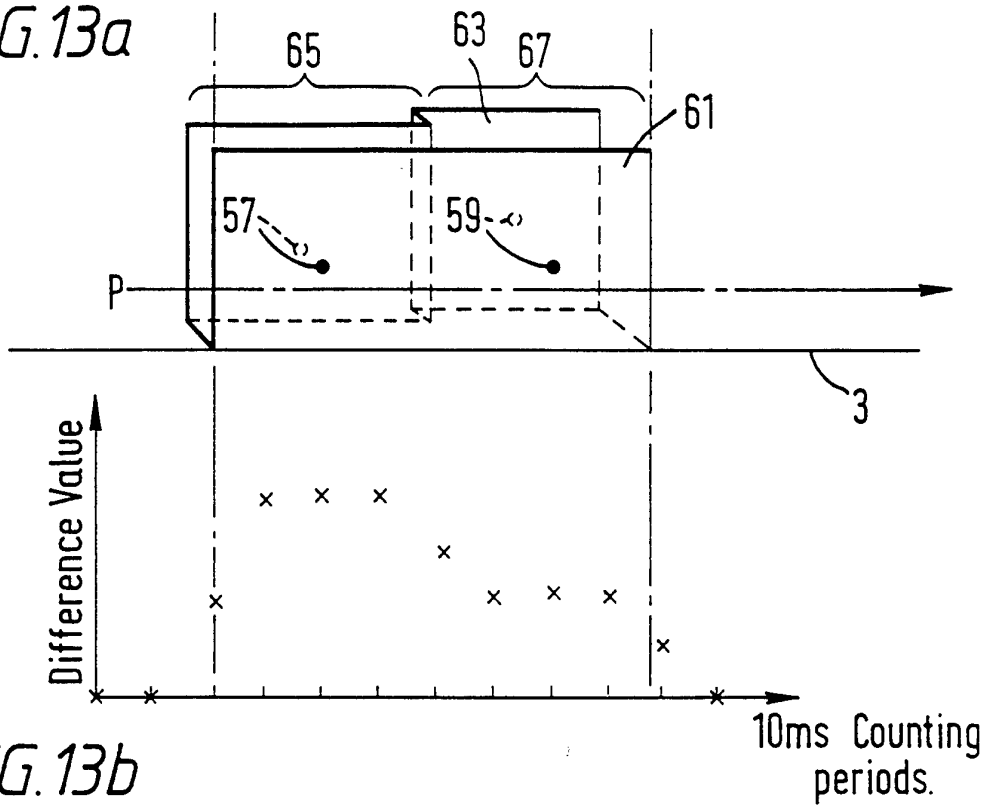

FIG. 13b

FIG. 14a

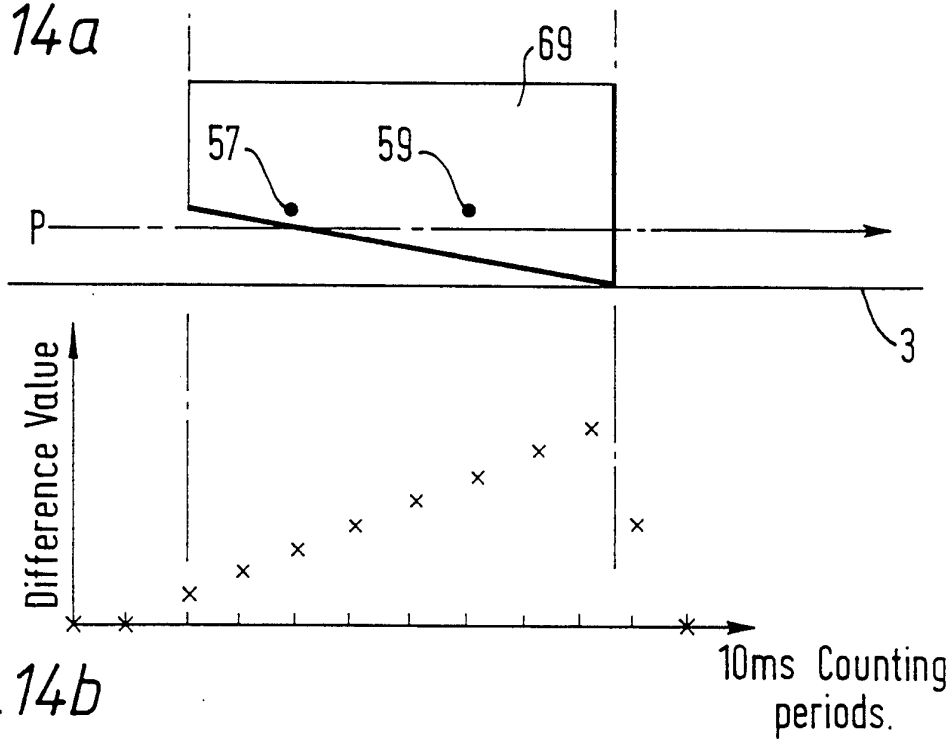

FIG. 14b

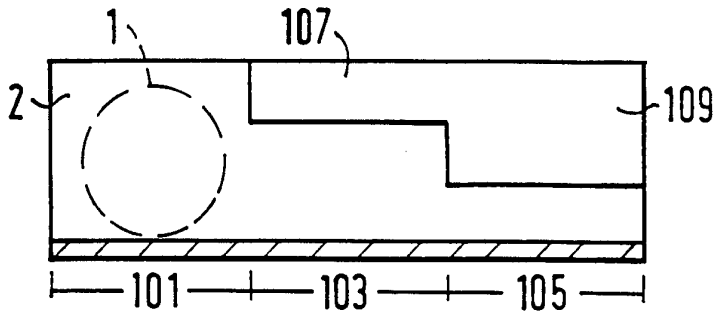

FIG. 15

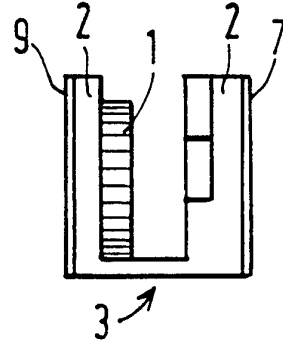

FIG. 16

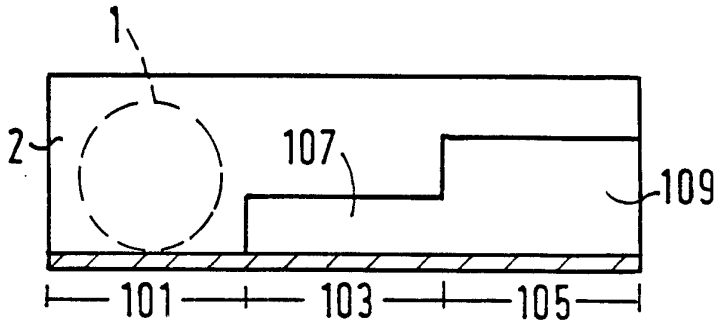

FIG. 17

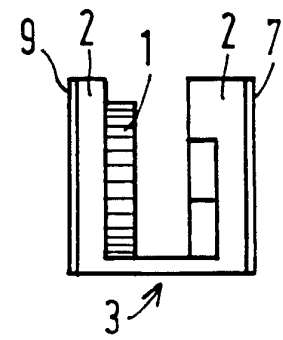

FIG. 18

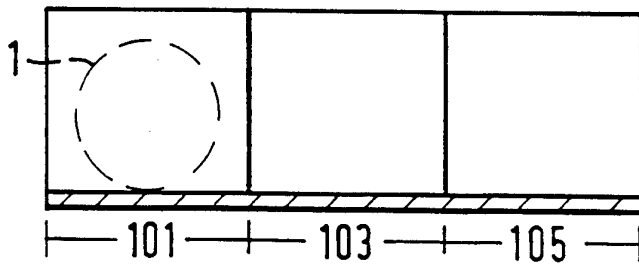

FIG. 19

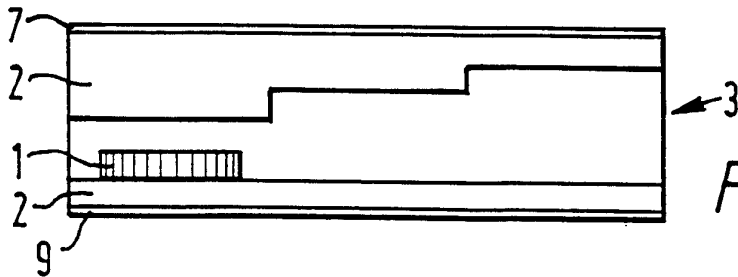

FIG. 20

8/11

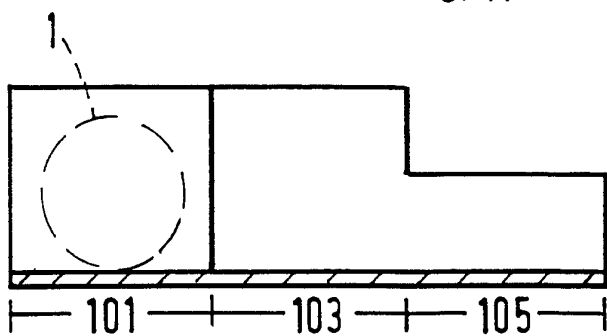

FIG. 21

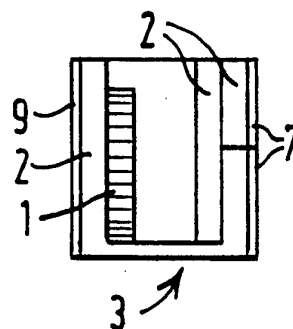

FIG. 23

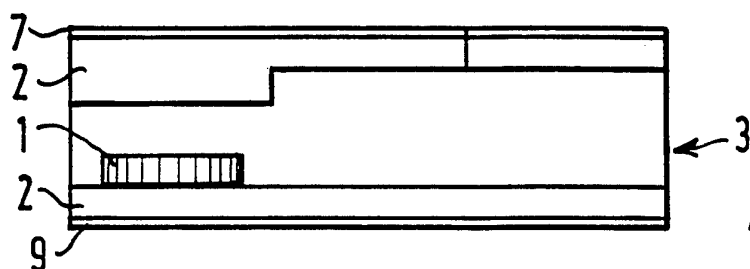

FIG. 22

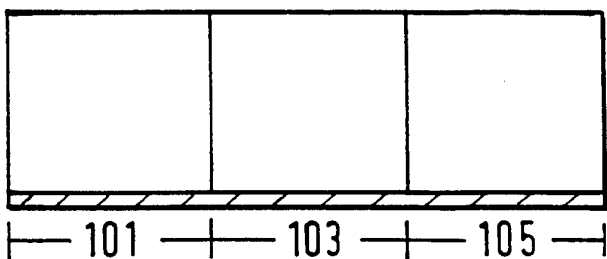

FIG. 24

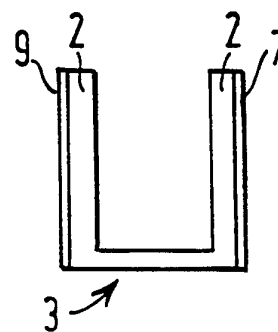

FIG. 25

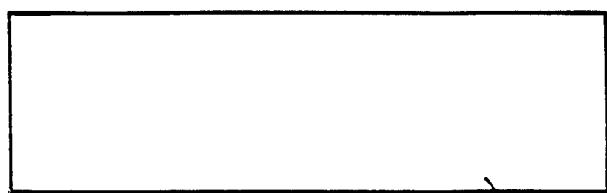

FIG. 26

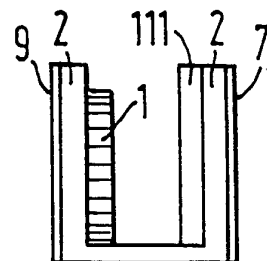

FIG. 27

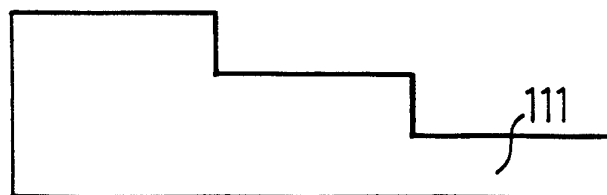

FIG. 28

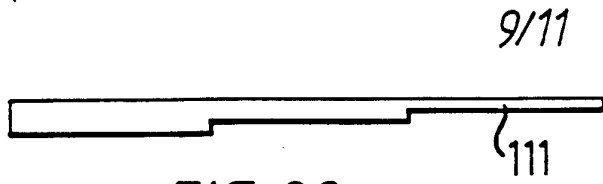

FIG. 29

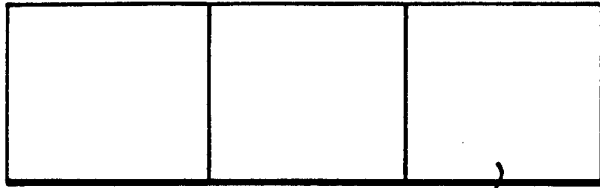

FIG. 30

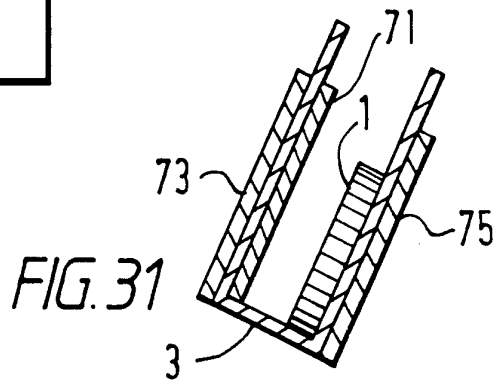

FIG. 31

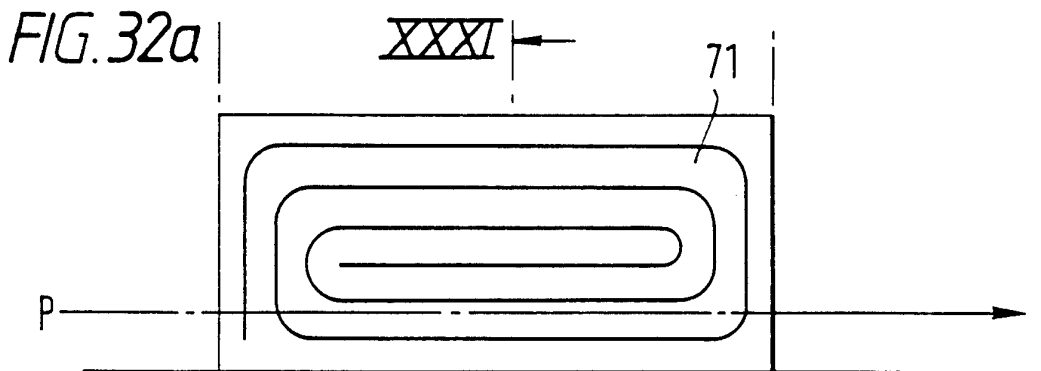

FIG. 32a

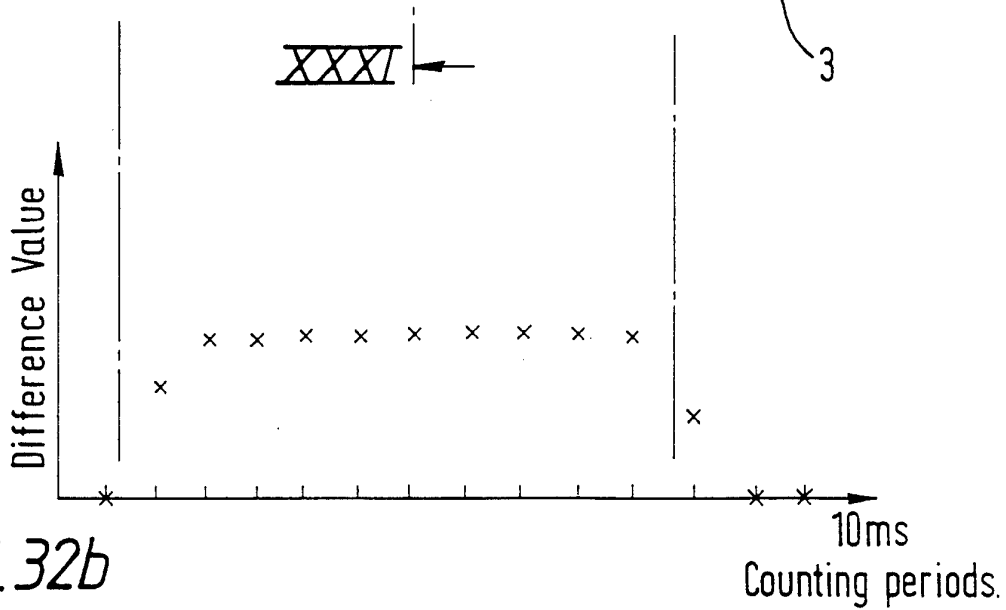
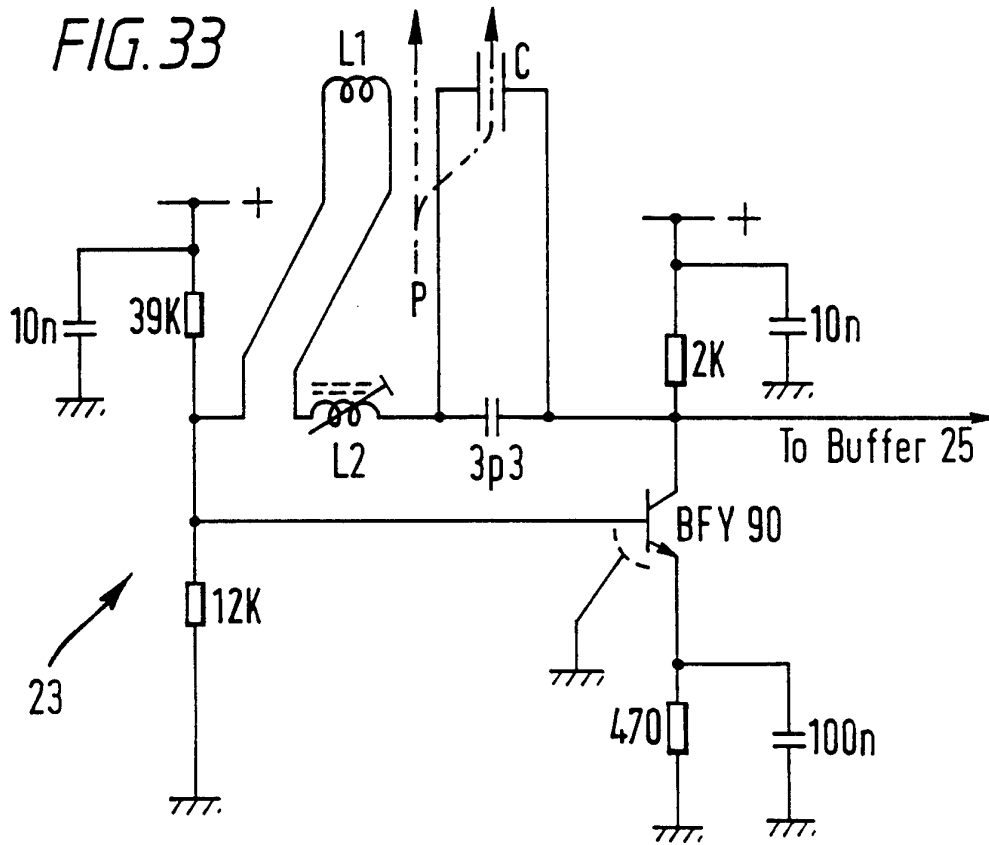

FIG. 32b

10/11

FIG. 33



11/11

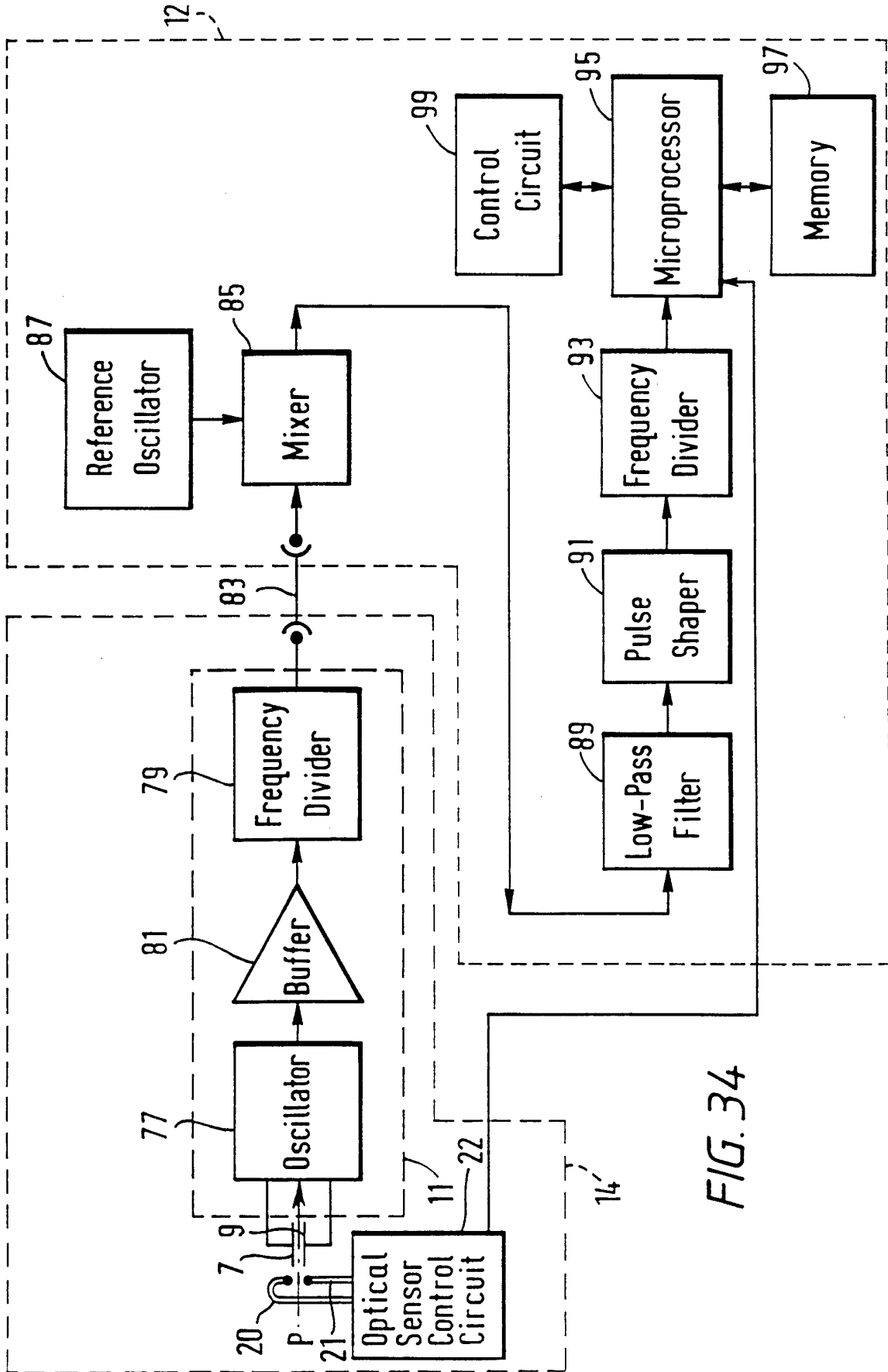

FIG. 34

INTERNATIONAL SEARCH REPORT

International Application No

PCT/GB 93/02119

<p>A. CLASSIFICATION OF SUBJECT MATTER IPC 5 G07F3/02</p>		
<p>According to International Patent Classification (IPC) or to both national classification and IPC</p>		
<p>B. FIELDS SEARCHED</p>		
<p>Minimum documentation searched (classification system followed by classification symbols) IPC 5 G07F G07D</p>		
<p>Documentation searched other than minimum documentation to the extent that such documents are included in the fields searched</p>		
<p>Electronic data base consulted during the international search (name of data base and, where practical, search terms used)</p>		
<p>C. DOCUMENTS CONSIDERED TO BE RELEVANT</p>		
Category *	Citation of document, with indication, where appropriate, of the relevant passages	Relevant to claim No.
X	CH,A,486 078 (REGA) 31 March 1970	1,2,6, 43,44, 46,49
A	see column 8, line 25 - column 9, line 59; claims; figures 1,2,5	
A	---	
A	GB,A,2 062 327 (GNT AUTOMATIC) 20 May 1981 cited in the application see abstract; claims; figures	3,5,7,8, 21, 32-37, 40-48
A	---	
A	EP,A,0 384 374 (URMET) 29 August 1990	1,6-8, 20-27, 40,47,48
	see abstract; claims; figures	

	-/--	
<p><input checked="" type="checkbox"/> Further documents are listed in the continuation of box C. <input checked="" type="checkbox"/> Patent family members are listed in annex.</p>		
<p>* Special categories of cited documents :</p>		
<p>"A" document defining the general state of the art which is not considered to be of particular relevance</p>		<p>"T" later document published after the international filing date or priority date and not in conflict with the application but cited to understand the principle or theory underlying the invention</p>
<p>"E" earlier document but published on or after the international filing date</p>		<p>"X" document of particular relevance; the claimed invention cannot be considered novel or cannot be considered to involve an inventive step when the document is taken alone</p>
<p>"L" document which may throw doubts on priority claim(s) or which is cited to establish the publication date of another citation or other special reason (as specified)</p>		<p>"Y" document of particular relevance; the claimed invention cannot be considered to involve an inventive step when the document is combined with one or more other such documents, such combination being obvious to a person skilled in the art.</p>
<p>"O" document referring to an oral disclosure, use, exhibition or other means</p>		<p>"&" document member of the same patent family</p>
<p>"P" document published prior to the international filing date but later than the priority date claimed</p>		
<p>Date of the actual completion of the international search</p>		<p>Date of mailing of the international search report</p>
<p>9 February 1994</p>		<p>25 -02- 1994</p>
<p>Name and mailing address of the ISA European Patent Office, P.B. 5818 Patentaan 2 NL - 2280 HV Rijswijk Tel. (+31-70) 340-2040, Tx. 31 651 epo nl, Fax: (+31-70) 340-3016</p>		<p>Authorized officer David, J</p>

INTERNATIONAL SEARCH REPORT

International Application No
PCT/GB 93/02119

C.(Continuation) DOCUMENTS CONSIDERED TO BE RELEVANT

Category *	Citation of document, with indication, where appropriate, of the relevant passages	Relevant to claim No.
A	EP,A,0 349 114 (NIPPON CONLUX) 3 January 1990	
A	--- EP,A,0 164 110 (TAMURA ELECTRIC WORKS) 11 December 1985 -----	

INTERNATIONAL SEARCH REPORT

Information on patent family members

International Application No

PCT/GB 93/02119

Patent document cited in search report	Publication date	Patent family member(s)	Publication date
CH-A-486078	15-02-70	DE-A- 1774448 FR-A- 2001962	06-04-72 03-10-69
GB-A-2062327	20-05-81	BE-A- 885741 CH-A- 648679 DE-A- 3038988 JP-A- 56096393 NL-A- 8005658 SE-B- 450303 SE-A- 8007291	16-02-81 29-03-85 30-04-81 04-08-81 22-04-81 15-06-87 19-04-81
EP-A-0384374	29-08-90	DE-D- 69003968	25-11-93
EP-A-0349114	03-01-90	JP-A- 2012491 US-A- 4951800	17-01-90 28-08-90
EP-A-0164110	11-12-85	JP-C- 1681142 JP-B- 3045435 JP-A- 60262292 DE-A- 3584187 US-A- 4660705	31-07-92 11-07-91 25-12-85 31-10-91 28-04-87