



⑫

## EUROPEAN PATENT SPECIFICATION

④⑤ Date of publication of patent specification :  
**06.07.94 Bulletin 94/27**

⑤① Int. Cl.<sup>5</sup> : **B08B 3/02**

②① Application number : **91101977.6**

②② Date of filing : **13.02.91**

---

⑤④ **Device for cleaning hand operated spray guns.**

---

③⑩ Priority : **19.02.90 SE 9000579**

⑦③ Proprietor : **DRESTER AB**  
**Hammarvägen 4**  
**S-232 37 Arlöv (SE)**

④③ Date of publication of application :  
**28.08.91 Bulletin 91/35**

⑦② Inventor : **Stern, Leif Einar**  
**Fattershus**  
**S-225 90 Lund (SE)**  
Inventor : **Beijbom, Peter**  
**Uardavagen 6c**  
**S-223 71 Lund (SE)**

④⑤ Publication of the grant of the patent :  
**06.07.94 Bulletin 94/27**

⑧④ Designated Contracting States :  
**DE FR GB IT NL SE**

⑦④ Representative : **Rottmann, Maximilian R. et al**  
**c/o Rottmann, Zimmermann + Partner AG**  
**Glattalstrasse 37**  
**CH-8052 Zürich (CH)**

⑤⑥ References cited :  
**US-A- 4 785 836**  
**US-A- 4 793 369**  
**US-A- 4 923 522**

**EP 0 443 421 B1**

---

Note : Within nine months from the publication of the mention of the grant of the European patent, any person may give notice to the European Patent Office of opposition to the European patent granted. Notice of opposition shall be filed in a written reasoned statement. It shall not be deemed to have been filed until the opposition fee has been paid (Art. 99(1) European patent convention).

---

## Description

The present invention relates to a device for cleaning hand operated spray guns, preferably hand operated spray guns used for painting vehicles in repair shops, whereby said device includes a sealable space with holders permitting positioning of preferably one spray gun at a time in such a way relative to nozzles that said nozzles can spray solvent onto and into said spray gun for cleaning thereof, and whereby said nozzles are provided for automatic cleaning of the spray gun.

In prior art devices such as disclosed in US-A-4 785 836, one uses the principle of pumping up the solvent, preferably thinner, from a container therefor by means of a solvent pump and direct jets of solvent onto and/or into the spray gun to be cleaned. A decisive problem with this principle is the difficulty, at a reasonable cost, of series production of a solvent pump which can withstand solvents for a longer period. This is due to the fact that solvents are so aggressive that gaskets and valves in the solvent pump are damaged. Furthermore, contaminated solvents are hard to pump, which might cause damages on movable parts of the pump because of overload. A third problem is that deposits (e.g. pigments and binders) from contaminated solvent jeopardize the function of the pump. Corrosive damages that water in solvents might cause on movable members, e.g. ball bearings, should also be mentioned.

Another problem with prior art principles is that it is not possible to carry out a manual cleaning, which is sometimes necessary or at least preferable.

The object of the present invention is to eliminate these problems and provide a substantially improved cleaning device. This is arrived at according to the invention by means of the characterizing features of claim 1.

While, in the device according to the invention, solvent is fed to the object by means of pressurized air from a pressurized-air system, the need for solvent pumps is completely eliminated. This means that the problem with frequent breakdowns because of pump damages is eliminated and that an expensive unit in the form of a solvent pump can be dispensed with. While additionally, the pressurized-air system according to the invention is adapted, when required, to feed solvent by means of pressurized air through a nozzle for manual cleaning, automatic as well as manual cleaning may be carried out with the one and same device.

The invention will be further described below with reference to the accompanying drawings, wherein

figure 1 is a perspective view of a cleaning device according to the invention for cleaning hand operated spray guns, whereby a part of the interior of the device is visible;

figure 2 is a plan view of a cleaning space in the cleaning device of fig. 1 with a spray gun located therein;

figure 3 is a plan view of the same cleaning space as in fig. 2 but with another type of spray gun located therein;

figure 4 is a circuit diagram over a system forming part of the cleaning device of the invention;

figure 5 is a section through a time valve forming part of the cleaning device;

figure 6 is a section through an ejector with a nozzle forming part of the cleaning device (the section taken horizontally and perpendicular through the detail as shown in fig. 4);

figures 7 and 8 are sections through two valves forming part of the cleaning device;

figure 9 is a section through a sedimentation device included in the cleaning device;

figure 10 is a schematic view of a cleaning device according to the invention provided with a ventilating device; and

figure 11 is a perspective view of an alternatively designed cleaning device according to the invention.

The cleaning device 1 illustrated in the figures is adapted for cleaning hand operated spray guns 2 or 3, preferably spray guns for painting vehicles in repair shops. Accessories to spray guns 2 or 3 and eventually other painting equipment such as brushes, tins, screens, gauge rods, etc., may also be cleaned in the cleaning device 1. The cleaning device 1 comprises a frame 4 with a base 5 and a lower space 6 for a tank 7 for clean solvent. A collecting space 8 is provided above the lower space 6 and above said collecting space a cleaning space 9 adapted for carrying out an automatic process for cleaning the spray gun 2 or 3. The cleaning space 9 is sealable by means of a door 10 which is situated in a half-open hood 11 wherein manual cleaning of the spray gun 2 or 3 may occur and which is connected to a pipe 12 in a ventilating device 77 (see fig. 10) for extraction of injurious gases from the hood 11.

For cleaning the spray gun 2 or 3 in the cleaning space, the cleaning device 1 includes a pressurized-air system 13 and a solvent system 14 (see fig. 4). The pressurized-air system 13 is through a pressurized-air conduit 15 connectable to a pressurized-air outlet (not shown) and in said conduit 15 there is provided a main valve 16 which opens when the cleaning device is set in operating condition.

The pressurized-air system 13 includes a pressurized-air conduit 15a through which pressurized air 17 flows to a regulator 18. From said regulator 18, pressurized air 17 flows through a pressurized-air conduit 19 and a branch conduit 19a to a first time valve 20 and through a branch conduit 19b to a second time valve 21. From the first time valve 20, the pressurized air may flow through a pressurized-air conduit

22 to branch conduits 22a and therefrom to ejectors 23 for recycled solvent (see fig. 6). From the second time valve 21, pressurized air may flow through the pressurized-air conduit 25 to a block valve 26 and if this valve is open, through a pressurized-air conduit 27 to branch conduits 27a and therefrom to ejectors 24 for clean solvent.

The pressurized-air system 13 is controlled by a time settable control device 28. This control device is through a conduit 29 connected with the pressurized-air system 13 and said conduit 29 has a valve 31a which is closed at rest but openable by means of a foot pedal 31b. When the valve 31a is opened, pressurized air can flow through a branch conduit 29a to a pressure chamber 21a in the time valve 21. In the branch conduit 29a there is provided a check valve 30 (see fig. 7) which lets through pressurized air to the time valve 20 via apertures 31 in a membrane-like valve body 32 when said valve body moves from its seat 33. Thereafter, a return spring 34 closes the check valve 30 such that the pressure chamber 20a in the time valve 20 can not communicate with the pressure chamber 21a in the time valve 21.

While pressurized air has flown into the pressure chamber 20a of the time valve 20, a diaphragm 35 and thus, a seat valve 36 is moved from its seat 37, whereby pressurized air can flow through the time valve 20 from the branch conduit 19a to the pressurized-air conduit 22. Hereby, a pressurized-air conduit 38 to the block valve 26 (see fig. 8) is put under pressure, the valve body 39 and spring 40 of said valve 26 being designed such that the valve body 39 engages a seat 41 and keeps the block valve 26 closed when the pressures in the conduits 38 and 25 are equal. Hereby, the block valve 26 prevents pressurized air from flowing from the pressurized-air conduit 25 to the pressurized-air conduit 27. The valve body 39 and spring 40 are also designed such that pressurized air in the conduit 25 is able to open the block valve 26 when the pressure in the conduit 38 ceases. By means of this block valve 26 it is obtained that as long as the supply of pressurized air through the time valve 20 to the ejectors 23 for contaminated (used) solvent is open, the supply of pressurized air through the time valve 21 to the ejectors 24 for clean solvent is closed.

The pressure chambers 20a, 21a in the time valves 20, 21 include capillary tubes 42 through which pressurized air slowly may leak out into the surroundings for obtaining atmospheric pressure in each pressure chamber 20a, 21a and thereby enable closing of the seat valve 36 by means of a return spring in cooperation with the pressure reduction across said seat valve. The capillary tubes 42 of the time valves 20, 21 are differently dimensioned such that the time valve 20 is open preferably for a shorter time (e.g. about 2 minutes) than the time valve 21 (which is open e.g. about 3 minutes).

The opening time of the seat valve 36 is dependent on the length and/or through-flow area of the capillary tube 42, and this time can be determined by providing a capillary tube 42 of a certain length and/or through-flow area and changed by replacing this tube by another capillary tube 42 of different length and/or through-flow area.

The control device 28 further includes a manometer 43, which through a conduit 44 is connected with the pressurized-air conduit 25 of the pressurized-air system 13. This manometer 43 is adapted to indicate when the cleaning automatism is in operation and it permits control of the air pressure in the pressurized-air system. The supply of pressurized air to the pressurized-air system 13 should be such that the manometer 43 shows a pressure of 5-6 bars.

In the pressurized-air conduit 15a of the pressurized-air system 13 there is provided a relief valve 45 which is controlled by a magnetic body 46 located in the door 10. The relief valve 45 operates such that the magnetic body 46 draws a valve ball (not shown) from its seat when the door 10 is closed, which means that the relief valve 45 is kept open when the door 10 is closed. When the door 10 is opened, the magnetic body 46 is moved such that it can not retain the valve ball, but said valve is by the pressurized air brought into engagement with its seat, whereby the relief valve 45 is closed.

The solvent system 14 includes a collecting and recycling device 47 for collecting used solvent 48 and for recycling thereof. The collecting space 8 for used solvent 48 forms part of the collecting and recycling device 47 and at least one suction hose 49 for feeding used solvent 48 to a suction opening 49a in the ejector 23 (see fig. 6) is inserted into said used solvent 48. The ejector 23 operates in a known manner, i.e. when pressurized air through the branch conduit 22a is fed through its nozzle to its venturi tube, used solvent 48 is due to the venturi effect drawn through the suction opening 49a into the flow of pressurized air and the pressurized air 50 containing used solvent 48 is discharged through at least one nozzle 51 for cleaning the spray gun 2 or 3.

Each nozzle 51 preferably consists of a unit in which the ejector 23 for used solvent 48 as well as the ejector 24 for clean solvent 53 are included. Passages for discharging used and clean solvent 48 and 53 respectively, and forming part of said unit, extend preferably in parallel to each other.

The solvent system 14 also includes a feed device 52 for feeding clean solvent 53 from the tank 7 to the ejector 24. For this object, at least one suction conduit 54 is inserted into the tank 7 and said suction conduit is adapted to feed clean solvent to a suction opening 55 in the ejector 24 (see fig. 6). The ejector 24 also operates in a known manner, i.e. when pressurized air through the branch conduit 27a is fed through its nozzle to its venturi tube, clean solvent is

due to the venturi effect drawn through the suction opening 55 into the flow of pressurized air, and the pressurized air 56 containing clean solvent 53 is discharged through the nozzle 51 (or a separate nozzle when required) for cleaning the spray gun 2 or 3.

The pressurized-air system 13 further includes a pressurized-air conduit 57 to an ejector (not shown) in a nozzle 58 for manual cleaning of the spray gun 2 or 3 and there is preferably provided in said conduit 57 a valve 59 which is operated by means of a foot pedal 60. A suction conduit 61 is preferably connected with the ejector in the nozzle 58 and clean solvent is sucked through this conduit from the tank 7 to the ejector for discharging pressurized air containing clean solvent 53 through the nozzle 58.

The nozzle 58 for manual cleaning of the spray gun 2 or 3 is preferably located in an upper space above the sealable space 9 and said nozzle 58 is preferably directed downwards towards said sealable space 9.

The upper space with the nozzle 58 may be defined by the half-open hood 11 (see fig. 1) and said space may communicate with the ventilating device 77 for ventilation thereof.

As an alternative, the nozzle 58 can preferably be provided in the sealable space 9 in such a way that the nozzle 58 is accessible when said sealable space 9 is opened.

As is apparent from fig. 11, the nozzle 58 can be located on the underside of a lid 78 which is pivotally mounted either for closing the sealable space 9 or for being set in an upwardly directed position U such that the sealable space 9 is open in an upwards direction. The nozzle 58 is preferably mounted such that it directs its jets of pressurized air containing solvent in a downward direction towards the sealable space 9 when the lid 78 is set in said upwardly directed position U.

The lid 78 preferably includes a screen 79 which screens the nozzle 58 in upwards direction and preferably also in sideways directions, whereby dispersion of unhealthy gases is obstructed.

The nozzle 58 is preferably located on the lid 78, but may alternatively be mounted on the screen 79 or on the lid 78 as well as on the screen 79.

A branch conduit 62 extends from the pressurized-air conduit 57 to an extraction device operated by pressurized air for sucking out or extracting injurious gases from the hood 11.

As is apparent from figs. 2 and 3, the cleaning space 9 is provided with a yoke 63 on which the spray gun 2 or 3 can be placed, with another yoke 64 for the paint container 65 for the spray gun (the so called cup) and a yoke 66 for the cap 67 to the paint container 65. The cleaning space 9 is also provided with a suitable number of nozzles 51 (here at least eight nozzles) for cleaning the spray gun interiorly and exteriorly and for cleaning the various parts of the spray

gun. For cleaning the interior of the spray gun 2 (the spray gun 2 has an overlying paint container 65), it can be provided with a so called extension tube 68 which is moved a distance into one of the nozzles 51 (see fig. 2). While the trigger of the spray gun is kept depressed by means of a wedge 69, the pressurized air containing solvent can pass through the paint passages of the spray gun during cleaning thereof and then out through the paint discharge nozzle 70 of said spray gun. The spray gun 2 or 3 is placed lying down in the cleaning space 9 with its paint discharge nozzle 70 situated in front of another nozzle 51 which is adapted to direct pressurized air containing solvent towards the exterior of the paint discharge nozzle 70 for cleaning thereof.

The pressurized air containing solvent and discharged by the nozzles 51 defines a turbulent cloud or mist of solvent in the cleaning space 9, whereby all exterior surfaces of the spray gun 2 or 3 or parts thereof are reached by the solvent.

Fig. 3 shows that a spray gun 3 with an underlying paint container 65 can also be cleaned in the cleaning space 9. Since such a spray gun 3 has a suction tube 68a, said gun is connected by inserting the end portion of said suction tube into one of the nozzles 51. The spray gun 3 is placed lying down on the yoke 63 and the paint container 65 is put in the yoke 64.

The collecting and recycling device 47 for collecting and recycling solvent, includes a sedimentation device 71 situated in the collecting space 8 and having guide means 72 in the shape of a screen like insert (see fig. 9) which is closed on top and open at the bottom. The guide means 72 has a somewhat smaller outer dimension than the inner dimension of the collecting space 8 in order to define a narrow gap 73 therearound. Used solvent 48 flowing down from the cleaning space 9 is guided outwardly towards the gap 73 by the guide means 72, flows into said gap and then slowly inwards beneath inwardly directed portions 74 of the guide means 72, whereby contaminants 75 in the solvent fall to the bottom region 76 of the collecting space 8. The suction hose 49 (or suction hoses) of the solvent system 14 is provided to open above the inwardly directed portions 74. It is hereby prevented that the suction hose 49 can reach down into the bottom region 76 and contaminants 75 included therein. Instead, it is ensured that the suction hose 49 sucks solvent from the area above the bottom region 76.

The ventilating device 77 is adapted to ventilate the sealable space 9 during and/or after the cleaning operation. If there is also an upper space to be ventilated, this can be done by means of said ventilating device 72 or by means of another ventilating device.

The embodiment of fig. 10 of the ventilating device 77 includes a suction passage 80 through which the sealable space 9 communicates with the tube 12.

In this suction passage 80 there is preferably provided a filter 81 through which air containing solvent flows to the tube 12. This filter 81 is designed such that it separates solvent from the air flowing there-through and it is mounted such that the separated solvent can flow back down into the sealed space 9.

The upper space within the hood 11 is also connected with the tube 12 which in turn is connected with a fan aggregate 82 for generating sufficient air flows in the ventilating device 77 for effective ventilation of the sealed space 9 and the upper space, such that persons working at the cleaning device 1 are not subjected to injurious gases.

The cleaning device 1 is operated as follows:

The door 10 to the cleaning space 9 is opened and e.g. 10-15 l of solvent, preferably thinner, is poured directly into said cleaning space 9. A tank 7 with e.g. 10 l of clean solvent 53, preferably thinner, is placed in the frame 4 and connected with the solvent system 14. The hand operated spray gun 2 or 3 to be cleaned, is arranged in a suitable manner in the cleaning space 9.

Before the cleaning automatism is started, the door 10 must be closed and then the valve 16 for the pressurized air 17 is opened. The cleaning automatism is started by pressing the foot pedal 31b to open the valve 31a. On the manometer 43 one can read if the cleaning automatism is operating and if the air pressure is correct. During a cleaning cycle of e.g. 3 minutes, cleaning with used solvent 48 may occur for about 2 minutes (pre-wash) and then with clean solvent 53 for about 1 minute (after-wash). When the washing cycle is finished, the pressure in the pressurized-air system 13 drops and ceases to exist when the pressurized air is cut off with the valve 16.

If one wishes to additionally clean any part of the spray gun 2 or 3, this cleaning may be carried out manually by means of the nozzle 58. This manual cleaning is started by opening the valve 51 by means of the foot pedal 60. It is also possible to clean only the spray gun 2 or 3 or any part thereof manually by means of the nozzle 58.

The invention is not limited to the device described above, but may vary within the scope of the following claims. Thus, cleaning may eventually occur only with recycled solvent or only with clean solvent. The cleaning process may be carried out only automatically or only manually and the time periods in a cleaning cycle can be adapted to the existing requirements. The spray guns and/or parts thereof may be arranged in other ways than described and the device may be used for other types of hand operated spray guns than the spray guns shown and for other accessories thereto.

The cleaning device can be designed in other ways than shown and described; the nozzles can e.g. be designed and located differently. There can be more than one nozzle 58 for manual cleaning and this

or these nozzles can be located in other ways than shown. Finally, it should be noted that other solvents than thinner can be used for cleaning with the device according to the invention.

## Claims

1. Device for cleaning hand operated spray guns, preferably hand operated spray guns used for painting vehicles in repair shops, whereby said device includes a sealable space (9) with holders (63 and/or 68) permitting positioning of preferably one spray gun (2 or 3) at a time in such a way relative to nozzles (51) that said nozzles can spray solvent (48 or 53) onto and into said spray gun (2 or 3) for cleaning thereof, and whereby said nozzles (51) are provided for automatic cleaning of the spray gun (2 or 3), **characterized in** that a pressurized-air system (13) is provided to spray solvent (48 or 53) by means of pressurized air (17) and without the use of liquid pump devices therefor, onto and into the spray gun (2 or 3) through said nozzles (51) for automatic cleaning of said spray gun, and that the pressurized-air system (13), when required, is provided also to permit spraying of solvent (48 or 53) onto the spray gun through at least one other nozzle (58) for manual cleaning of said spray gun.
2. Device according to claim 1, **characterized in** that the device permits collection of used solvent (48) and recycling thereof for cleaning of the spray gun (2 or 3) with recycled solvent (48) and permits supply of clean solvent (53) for subsequent cleaning of the spray gun (2 or 3) therewith.
3. Device according to claim 1 or 2, **characterized in** that nozzles (51) for automatic cleaning of the spray gun (2 or 3) discharge solvent (48 or 53) in such a manner in the space (9) that a turbulent cloud is formed consisting of an airborne solvent around the spray gun (2 or 3) so that solvent (48 or 53) may deposit on those surfaces of the spray gun facing away from said nozzles (51).
4. Device according to any preceding claim, **characterized in** that the space (9) is connected with a ventilating device (77) which is provided to ventilate said space (9) during and/or after the cleaning process.
5. Device according to claim 4, **characterized in** that the ventilating device (77) includes a filter (81) for separating solvent (48 or 53) from air flowing therethrough and that the filter (81) preferably is provided such that the solvent (48 or 53) separated therein or portions thereof can

flow back into the space (9).

6. Device according to any preceding claim, **characterized in** that the nozzle (58) for manual cleaning of the spray gun (2 or 3) is provided in an upper space situated above the sealable space (9), whereby said nozzle (58) preferably is directed downwards towards the sealable space (9).
7. Device according to claim 6, **characterized in** that the upper space with the nozzle (58) for manual cleaning of the spray gun (2 or 3) is defined by a half-open hood (11) and that said upper space is connected with a ventilating device (77) for ventilation of said space.
8. Device according to any of claims 1-5, **characterized in** that the nozzle (58) for manual cleaning of the spray gun (2 or 3) is located in the sealable space (9) in such a manner that said nozzle becomes accessible when the sealable space (9) is opened.
9. Device according to any of claims 1-5 or 8, **characterized in** that the nozzle (58) for manual cleaning of the spray gun (2 or 3) is located under a lid (78) which is pivotally mounted for cleaning or opening the sealable space (9), whereby said nozzle (58) is directly or indirectly corrected with said lid (78) in such a manner that said nozzle discharge pressurized air containing solvent in a direction downwards towards the sealable space (9) when said lid (78) is set in an upwardly directed position (U) keeping the sealable space (9) open, and that said lid (78) preferably has a screen (79) for screening said nozzle (58) in an upwards direction and preferably also in lateral directions.
10. Device according to any preceding claim, **characterized in** that at least one of said nozzles (51) has an ejector (23) for used solvent (48) and another ejector (24) for clean solvent (53), whereby passages for discharging used and clean solvent (48, 53) respectively, extend in parallel with each other.
11. Device according to any preceding claim, **characterized in** that a time settable control device (28) is provided to permit cleaning of the spray guns (2 or 3) for a certain time period with used solvent (48) and then with clean solvent (53) for a certain time period.
12. Device according to claim 11, **characterized in** that the time settable control device (28) includes a time valve (20 or 21) having a seat valve

(36) which is located in the pressurized-air system (13) and adapted to open and close said system, that the seat valve (36) cooperates with a diaphragm (35) in a pressure chamber (20a, 21a) which is put under pressure by bringing it in contact with the pressurized-air system (13) for opening the seat valve (36) against the action of a return spring, and thereafter ventilating said pressure chamber (20a, 21a) by means of restriction means (42) for obtaining atmospheric pressure in said pressure chamber and thereby enable the return spring to close the seat valve (36) in cooperation with the pressure drop across said valve.

13. Device according to claim 12, **characterized in** that the restriction means is a capillary tube (42), whereby the opening time of the seat valve (36) is depending on the length and/or through-flow area of the capillary tube (42), and that the opening time of the seat valve (36) can be determined by providing a capillary tube (42) of a certain length and/or through-flow area and changed by replacing this tube by another capillary tube (42) of different length and/or through-flow area.

14. Device according to any preceding claim, **characterized in** that a collecting and recycling device (47) for collecting and recycling of solvent includes a sedimentation device (71) with guide means (72) for guiding downwardly flowing solvent (48) to flow down into a gap (73) extending therearound, and then slowly inwards beneath inwardly directed portions (74) of the guide means (72), during setting of contaminants (75) in the bottom region (76) of the space (8), whereby at least one suction hose (49) forming part of the solvent system (14) is provided to open above the inwardly directed portions (74) of said guide means (72) for sucking solvent (48) from an area above the bottom region (76).

15. Device according to any preceding claim, **characterized in** that the spray gun (2 or 3) can be positioned lying down in the space (8) adapted therefor.

## Patentansprüche

1. Vorrichtung zum Reinigen handbetriebener Spritzpistolen, vorzugsweise handbetriebener Spritzpistolen, welche zum Spritzen von Fahrzeugen in Reparaturwerkstätten verwendet werden, wobei die genannte Vorrichtung einen abdichtbaren Raum (9) mit Haltern (63 und/oder 68) aufweist, welche es erlauben, vorzugsweise eine Spritzpistole (2 oder 3) auf einmal bezüglich Dü-

- sen (51) so zu positionieren, dass die genannten Düsen Lösungsmittel (48 oder 53) zwecks Reinigung der genannten Spritzpistole (2 oder 3) auf diese und in diese hinein spritzen können, und wobei die genannten Düsen (51) zur automatischen Reinigung der Spritzpistole (2 oder 3) vorgesehen sind, dadurch gekennzeichnet, dass:
- ein Druckluftsystem (13) vorgesehen ist, um Lösungsmittel (48 oder 53) zwecks Reinigung der genannten Spritzpistole (2 oder 3) mittels Druckluft (17) und ohne Verwendung einer Flüssigkeitspumpe durch die Düsen (51) auf die Spritzpistole und in diese hinein zu spritzen; und
  - das Druckluftsystem (13) nötigenfalls auch so ausgebildet ist, dass es das Spritzen von Lösungsmittel (48 oder 53) auf die Spritzpistole durch wenigstens eine andere Düse (58) zwecks manueller Reinigung der genannten Spritzpistole ermöglicht.
2. Vorrichtung nach Anspruch 1, dadurch gekennzeichnet, dass:
- sie zwecks Reinigung der Spritzpistole (2 oder 3) mit recyceltem Lösungsmittel (48) das Sammeln von gebrauchtem Lösungsmittel (48) und dessen Recyclierung ermöglicht; und
  - sie die Zufuhr von sauberem Lösungsmittel (53) zwecks nachfolgender Reinigung der Spritzpistole (2 oder 3) mit solchem ermöglicht.
3. Vorrichtung nach Anspruch 1 oder 2, dadurch gekennzeichnet, dass zwecks automatischer Reinigung der Spritzpistole (2 oder 3) Düsen (51) Lösungsmittel (48 oder 53) in solcher Weise in den Raum (9) einspeisen, dass um die Spritzpistole (2 oder 3) herum eine turbulente Wolke gebildet wird, welche aus in der Luft schwebendem Lösungsmittel besteht, so dass das Lösungsmittel (48 oder 53) sich auf jenen Oberflächen der Spritzpistole niederschlagen kann, welche von den genannten Düsen (51) abgewandt sind.
4. Vorrichtung nach einem der vorangehenden Ansprüche, dadurch gekennzeichnet, dass der Raum (9) mit einer Ventilationsvorrichtung (77) verbunden ist, welche zur Ventilation des genannten Raumes (9) während und/oder nach dem Reinigungsprozess vorgesehen ist.
5. Vorrichtung nach Anspruch 4, dadurch gekennzeichnet, dass:
- die Ventilationsvorrichtung (77) einen Filter (81) zum Abscheiden des Lösungsmittels (48 oder 53) aus der ihn durchströmenden Luft aufweist; und
- vorzugsweise der Filter (81) so ausgebildet ist, dass das in ihm abgeschiedene Lösungsmittel (48 oder 53), oder Teile davon, in den Raum (9) zurückfließen können.
6. Vorrichtung nach einem der vorangehenden Ansprüche, dadurch gekennzeichnet, dass die Düse (58) zur manuellen Reinigung der Spritzpistole (2 oder 3) in einem oberhalb des abdichtbaren Raumes (9) angeordneten oberen Raum angeordnet ist, wobei die genannte Düse (58) vorzugsweise nach unten gegen den abdichtbaren Raum (9) gerichtet ist.
7. Vorrichtung nach Anspruch 6, dadurch gekennzeichnet, dass:
- der obere Raum mit der Düse (58) zur manuellen Reinigung der Spritzpistole (2 oder 3) durch eine halboffene Haube (11) definiert wird; und
  - der genannte obere Raum mit einer Ventilationsvorrichtung (77) zur Ventilation des genannten Raumes versehen ist.
8. Vorrichtung nach einem der Ansprüche 1 bis 5, dadurch gekennzeichnet, dass die Düse (58) zur manuellen Reinigung der Spritzpistole (2 oder 3) in dem abdichtbaren Raum (9) derart angeordnet ist, dass die genannte Düse zugänglich ist, wenn der abdichtbare Raum (9) geöffnet wird.
9. Vorrichtung nach einem der Ansprüche 1 bis 5 oder 8, dadurch gekennzeichnet, dass die Düse (58) zur manuellen Reinigung der Spritzpistole (2 oder 3) unter einem Deckel (78) angeordnet ist, welcher zwecks Öffnen oder Schließen des abdichtbaren Raumes (9) schwenkbar montiert ist, wobei:
- die genannte Düse (58) mit dem genannten Deckel (78) direkt oder indirekt derart verbunden ist, dass die genannte Düse lösungsmittelhaltige Druckluft in einer Richtung nach unten gegen den abdichtbaren Raum (9) einspeist, wenn der genannte Deckel (78) nach oben in die Stellung U gebracht ist; und
  - der genannte Deckel (78) vorzugsweise einen Schirm (79) zum Abschirmen der genannten Düse (58) gegen oben und vorzugsweise auch gegen die Seiten hin aufweist.
10. Vorrichtung nach einem der vorangehenden Ansprüche, dadurch gekennzeichnet, dass mindestens eine der genannten Düsen (51) einen Ejektor (23) für gebrauchtes Lösungsmittel (48) und einen anderen Ejektor (24) für sauberes Lösungsmittel (53) aufweist, wobei die Durchlässe

zur Einspeisung von gebrauchtem und sauberem Lösungsmittel (48, 53) parallel zueinander verlaufen.

- 5
11. Vorrichtung nach einem der vorangehenden Ansprüche, dadurch gekennzeichnet, dass eine zeiteinstellbare Steuervorrichtung (28) vorgesehen ist, um während einer bestimmten Zeitdauer eine Reinigung der Spritzpistole (2 oder 3) mit gebrauchtem Lösungsmittel (48) und danach mit sauberem Lösungsmittel (53) zu erlauben.
- 10
12. Vorrichtung nach Anspruch 11, dadurch gekennzeichnet, dass:
- die zeiteinstellbare Steuervorrichtung (28) ein Zeitventil (20 oder 21) aufweist, welches mit einem im Druckluftsystem (13) angeordneten und zum Öffnen und Schliessen des genannten Systems ausgebildeten Bodenventil (36) versehen ist; und
  - das Bodenventil (36) zusammenarbeitet mit einer Membran (35) in einer Druckkammer (20a, 21a), welche unter Druck gesetzt wird, indem sie mit dem Druckluftsystem (13) in Verbindung gebracht wird, um das Bodenventil (36) entgegen der Wirkung einer Rückstellfeder zu öffnen und danach die genannte Druckkammer (20a, 21a) mittels eines Begrenzungsmittels (42) zu ventilierten, um in der Druckkammer atmosphärischen Druck herzustellen und dadurch zu ermöglichen, dass die Rückstellfeder in Zusammenarbeit mit dem Druckabfall im genannten Ventil das Bodenventil (36) schliesst.
- 15
13. Vorrichtung nach Anspruch 13, dadurch gekennzeichnet, dass:
- das Begrenzungsmittel (42) ein Kapillarrohr (42) ist, wobei die Öffnungszeit des Bodenventils (36) von der Länge und/oder der Querschnittsfläche des Kapillarrohres (42) abhängt; und
  - die Öffnungszeit des Bodenventils (36) durch Einsatz eines Kapillarrohres (42) bestimmter Länge und/oder Querschnittsfläche eingestellt und durch Auswechseln dieses Rohres gegen ein anderes Kapillarrohr (42) von unterschiedlicher Länge und/oder Querschnittsfläche verändert werden kann.
- 20
- 25
- 30
- 35
- 40
- 45
- 50
- 55
14. Vorrichtung nach einem der vorangehenden Ansprüche, dadurch gekennzeichnet, dass die Sammel- und Recyclier-Vorrichtung (47) zum Sammeln und Recyclieren von Lösungsmittel eine Sedimentierungsvorrichtung (71) mit Leitmitteln (72) aufweist, welche das abwärts fließen-

de Lösungsmittel (48) in einen Spalt (73), welcher sich um diese herumerstreckt, und danach unterhalb eines einwärtsgerichteten Teiles (74) langsam einwärts leiten, während sich Verunreinigungen (75) im Bodenbereich (76) des Raumes (8) absetzen, wobei mindestens ein Bestandteil des Lösungsmittelsystems (14) bildender Saugschlauch (49) vorgesehen ist, welcher oberhalb des einwärtsgerichteten Teiles (74) der genannten Leitmittel (72) endet, um Lösungsmittel aus dem Bereich oberhalb der Bodenbereiches (76) abzusaugen.

- 15
15. Vorrichtung nach einem der vorangehenden Ansprüche, dadurch gekennzeichnet, dass die Spritzpistole (2 oder 3) in dem dazu angepassten Raum (8) positioniert werden kann.

## Revendications

- 20
- 25
- 30
- 35
- 40
- 45
- 50
- 55
1. Dispositif pour nettoyer des pistolets de pulvérisation actionnés à la main, avantageusement des pistolets de pulvérisation actionnés à la main utilisés pour peindre des véhicules dans les ateliers de réparation, ledit dispositif comprenant un espace pouvant être fermé hermétiquement (9) comportant des supports (63 et/ou 68) permettant le positionnement d'avantageusement un pistolet de pulvérisation (2 ou 3) à la fois de telle façon' par rapport à des buses (51) que lesdites buses puissent pulvériser du solvant (48 ou 53) sur et dans ledit pistolet de pulvérisation (2 ou 3) pour le nettoyer, et lesdites buses (51) étant équipées pour le nettoyage automatique du pistolet de pulvérisation (2 ou 3), caractérisé en ce qu'un système à air pressurisé (13) est prévu pour pulvériser du solvant (48 ou 53) au moyen d'air pressurisé (17) et sans utiliser de dispositifs à pompage de liquide prévus à cet effet, sur et dans le pistolet de pulvérisation (2 ou 3) à travers lesdites buses (51) pour le nettoyage automatique dudit pistolet de pulvérisation, et en ce que le système à air pressurisé (13), lorsque c'est nécessaire, est aussi équipé pour permettre la pulvérisation de solvant (48 ou 53) sur le pistolet de pulvérisation au moyen d'au moins une autre buse (58) pour le nettoyage manuel dudit pistolet de pulvérisation.
  2. Dispositif selon la revendication 1, caractérisé en ce que le dispositif permet la récupération du solvant usagé (48) et son recyclage pour le nettoyage du pistolet de pulvérisation (2 ou 3) avec du solvant recyclé (48) et permet la fourniture de solvant propre (53) pour le nettoyage ultérieur du pistolet de pulvérisation (2 ou 3) à l'aide de ce solvant.

3. Dispositif selon la revendication 1 ou 2, caractérisé en ce que des buses (51) pour le nettoyage automatique du pistolet de pulvérisation (2 ou 3) éjectent du solvant (48 ou 53) de telle façon dans l'espace (9) qu'un nuage turbulent se forme, constitué de solvant en suspension dans l'espace (9) autour du pistolet de pulvérisation (2 ou 3), de sorte que le solvant (48 ou 53) peut se déposer sur les surfaces du pistolet de pulvérisation situées à l'opposé desdites buses (51). 5 10
4. Dispositif selon l'une quelconque des revendications précédentes, caractérisé en ce que l'espace (9) est relié à un dispositif de ventilation (77) qui est prévu pour ventiler ledit espace (9) pendant et/ou après le processus de nettoyage. 15
5. Dispositif selon la revendication 4, caractérisé en ce que le dispositif de ventilation (77) comprend un filtre (81) pour séparer le solvant (48 ou 53) de l'air qui s'écoule au travers et en ce que le filtre (81) est avantageusement équipé de sorte que le solvant (48 ou 53) qui y est séparé ou une partie de celui-ci puisse retourner dans l'espace (9). 20 25
6. Dispositif selon l'une quelconque des revendications précédentes, caractérisé en ce que la buse (58) pour le nettoyage manuel du pistolet de pulvérisation (2 ou 3) est disposée dans un espace supérieur situé au-dessus de l'espace pouvant être fermé hermétiquement (9), ladite buse (58) étant avantageusement dirigée vers le bas en direction de l'espace pouvant être fermé hermétiquement (9). 30 35
7. Dispositif selon la revendication 6, caractérisé en ce que l'espace supérieur contenant la buse (58) pour le nettoyage manuel du pistolet de pulvérisation (2 ou 3) est délimité par une hotte à demi ouverte (11) et en ce que ledit espace supérieur est relié à un dispositif de ventilation (77) pour la ventilation dudit espace. 40
8. Dispositif selon l'une quelconque des revendications 1 à 5, caractérisé en ce que la buse (58) pour le nettoyage manuel du pistolet de pulvérisation (2 ou 3) est située dans l'espace pouvant être fermé hermétiquement (9) de telle façon que ladite buse devient accessible quand l'espace pouvant être fermé hermétiquement (9) est ouvert. 45 50
9. Dispositif selon l'une quelconque des revendications 1 à 5 ou 8, caractérisé en ce que la buse (58) pour le nettoyage manuel du pistolet de pulvérisation (2 ou 3) est située sous un couvercle (78) qui est monté de façon pivotante pour fermer ou ouvrir l'espace pouvant être fermé hermétiquement (9), ladite buse (58) étant directement ou indirectement reliée audit couvercle (78) de façon telle que ladite buse éjecte de l'air pressurisé contenant du solvant dans une direction vers le bas en direction de l'espace pouvant être fermé hermétiquement (9) quand ledit couvercle (78) est placé dans une position dirigée vers le haut (U) maintenant l'espace pouvant être fermé hermétiquement (9) ouvert, et en ce que ledit couvercle (78) présente avantageusement un écran (79) formant barrière pour ladite buse (58) dans une direction vers le haut et avantageusement aussi dans des directions latérales. 55
10. Dispositif selon l'une quelconque des revendications précédentes, caractérisé en ce qu'au moins une desdites buses (51) comporte un éjecteur (23) pour le solvant usagé (48) et un autre éjecteur (24) pour le solvant propre (53), les passages d'éjection des solvants usagé et propre (48, 53), respectivement, s'étendant parallèlement l'un à l'autre.
11. Dispositif selon l'une quelconque des revendications précédentes, caractérisé en ce qu'un dispositif de commande avec programmation du temps (28) est prévu pour permettre le nettoyage des pistolets de pulvérisation (2 ou 3) pendant une certaine période de temps avec du solvant usagé (48) et ensuite avec du solvant propre (53) pendant une certaine période de temps.
12. Dispositif selon la revendication 11, caractérisé en ce que le dispositif de commande avec programmation du temps (28) comprend une valve de minuterie (20 ou 21) comportant une valve à siège (36) qui est située dans le système à air pressurisé (13) et destinée à ouvrir et fermer ledit système, en ce que la valve à siège (36) coopère avec un diaphragme (35) dans une chambre de pression (20a, 21a) qui est placée sous pression en la mettant en contact avec le système à air pressurisé (13) pour ouvrir la valve à siège (36) à l'encontre de l'action d'un ressort de rappel, et ensuite ventiler ladite chambre de pression (20a, 21a) par l'intermédiaire d'un moyen de restriction (42) pour obtenir la pression atmosphérique dans ladite chambre de pression et ainsi permettre au ressort de rappel de fermer la valve à siège (36) en coopération avec la chute de pression dans ladite valve.
13. Dispositif selon la revendication 12, caractérisé en ce que le moyen de restriction est un tube capillaire (42), la durée d'ouverture de la valve à siège étant fonction de la longueur et/ou de la section d'écoulement du tube capillaire (42), et en ce que la durée d'ouverture de la valve à siège (36) peut être déterminée en utilisant un tube ca-

pillaire (42) d'une certaine longueur et/ou d'une certaine section d'écoulement et modifiée en remplaçant ce tube par un autre tube capillaire (42) de longueur et/ou section d'écoulement différente(s). 5

14. Dispositif selon l'une quelconque des revendications précédentes, caractérisé en ce qu'un dispositif de récupération et de recyclage (47) pour récupérer et recycler le solvant comprend un dispositif de sédimentation (71) comportant des moyens de guidage (72) pour guider le solvant (48) qui s'écoule vers le bas afin qu'il s'écoule dans un intervalle (73) s'étendant autour d'eux, et ensuite lentement vers l'intérieur sous des parties des moyens de guidage (72) orientées vers l'intérieur, pendant le dépôt de polluants (75) dans la région de fond (76) de l'espace (8), au moins un conduit d'aspiration (49) faisant partie du système à solvant (14) étant prévu pour déboucher au-dessus des parties (74) desdits moyens de guidage (72) orientées vers l'intérieur pour aspirer le solvant (48) à partir d'une zone au-dessus de la région de fond (76). 10  
15  
20  
25

15. Dispositif selon l'une quelconque des revendications précédentes, caractérisé en ce que le pistolet de pulvérisation (2 ou 3) peut être disposé de façon à être couché dans l'espace (8) qui y est adapté. 30

35

40

45

50

55

Fig. 1

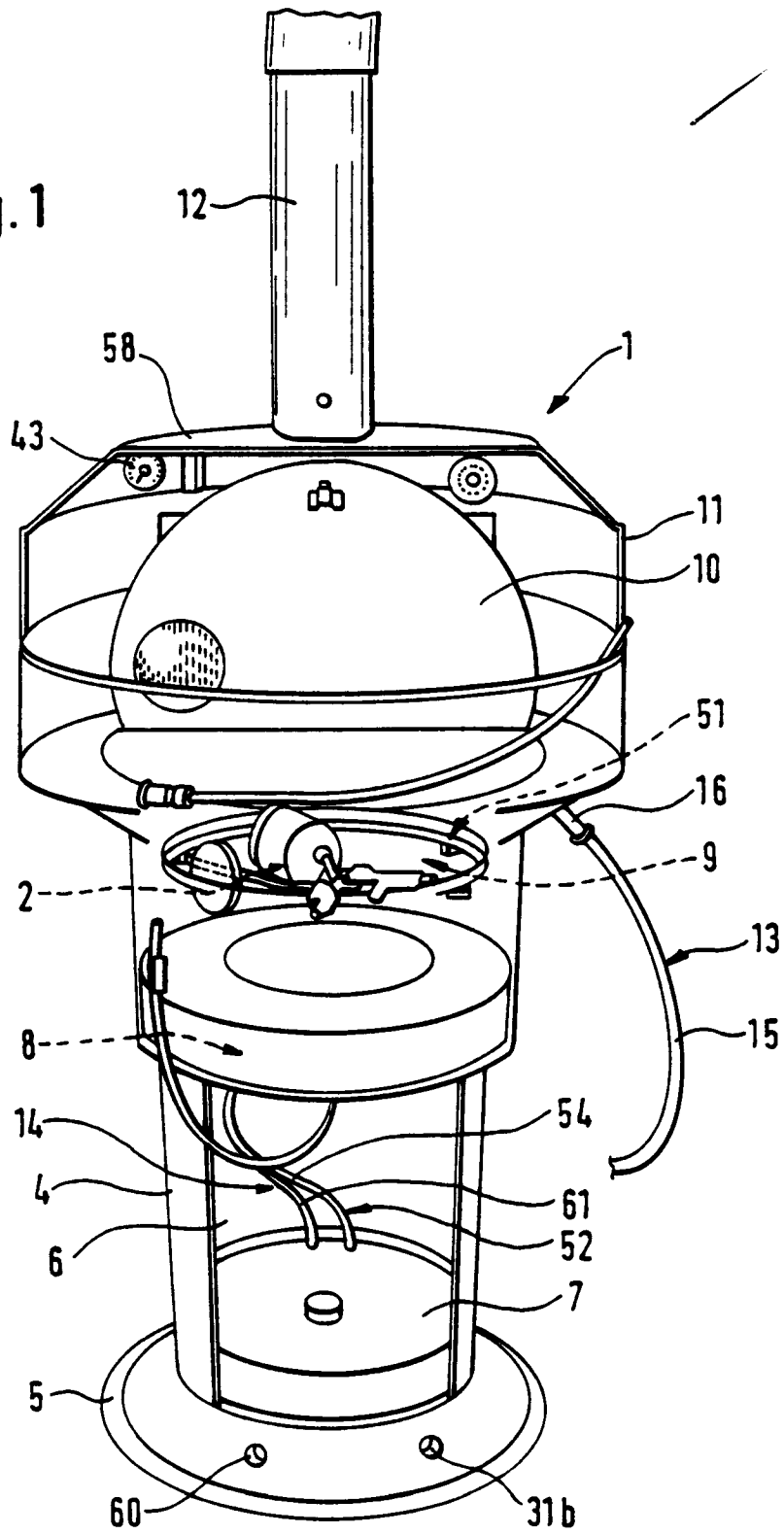

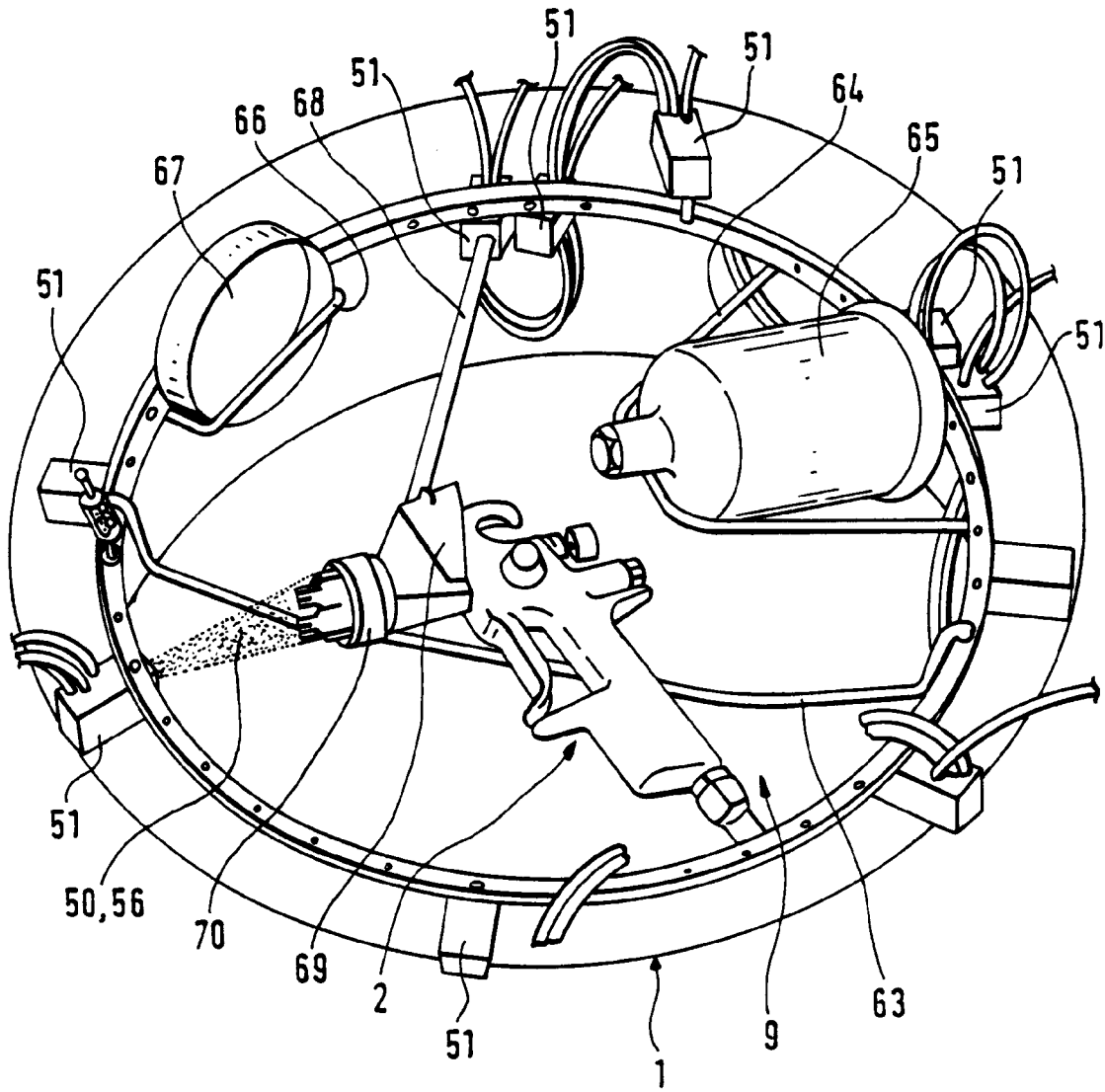

Fig. 2



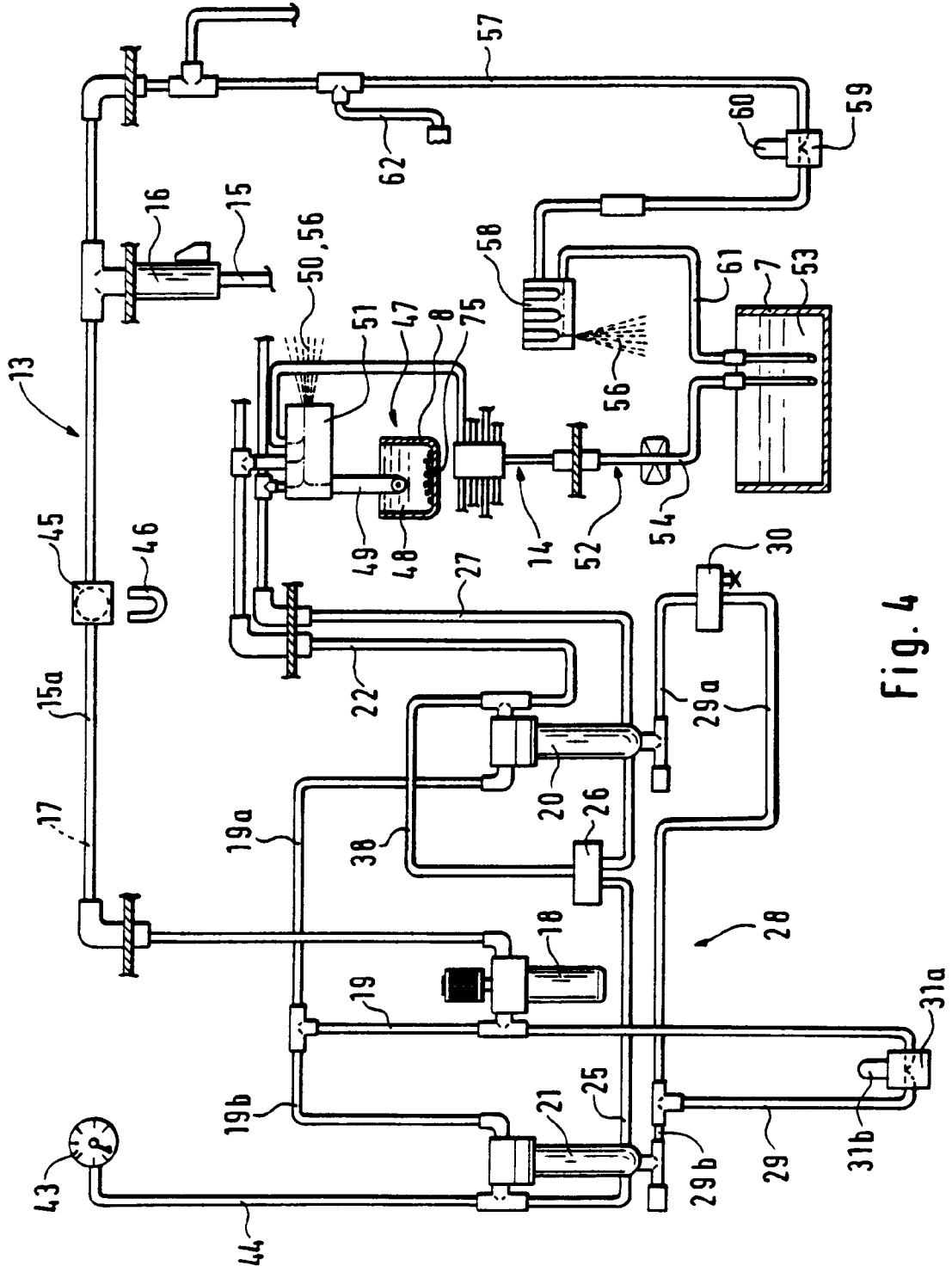

Fig. 4

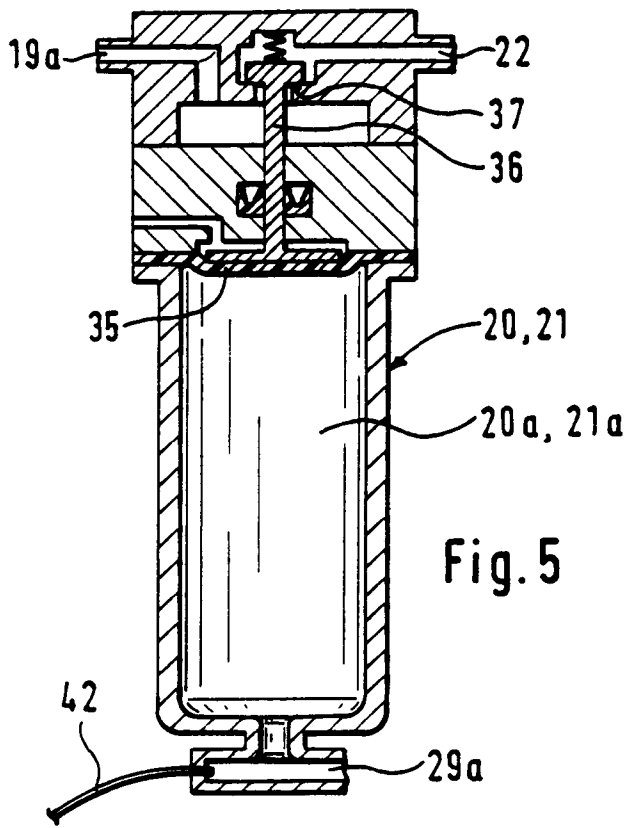

Fig. 5

Fig. 6

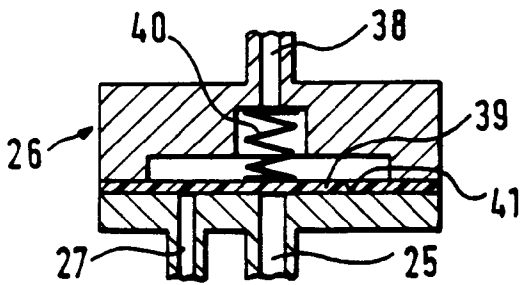
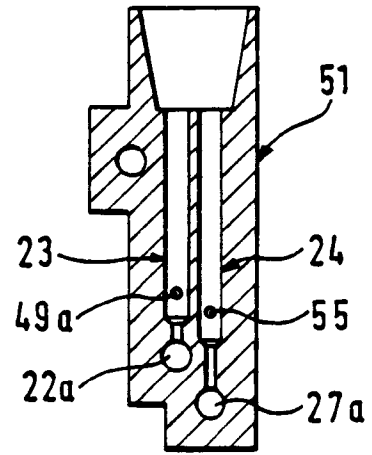

Fig. 8

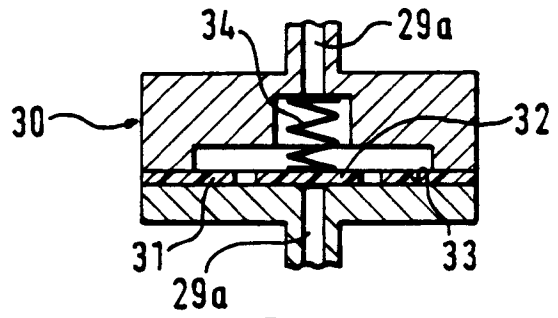

Fig. 7

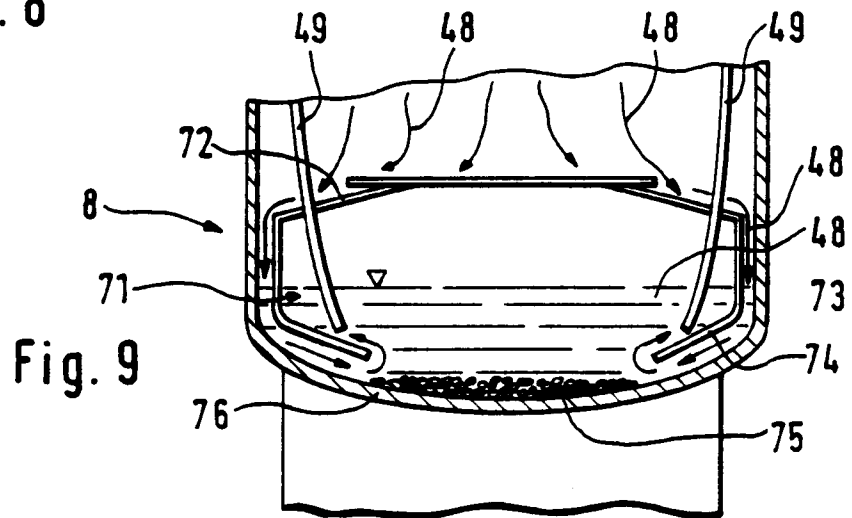
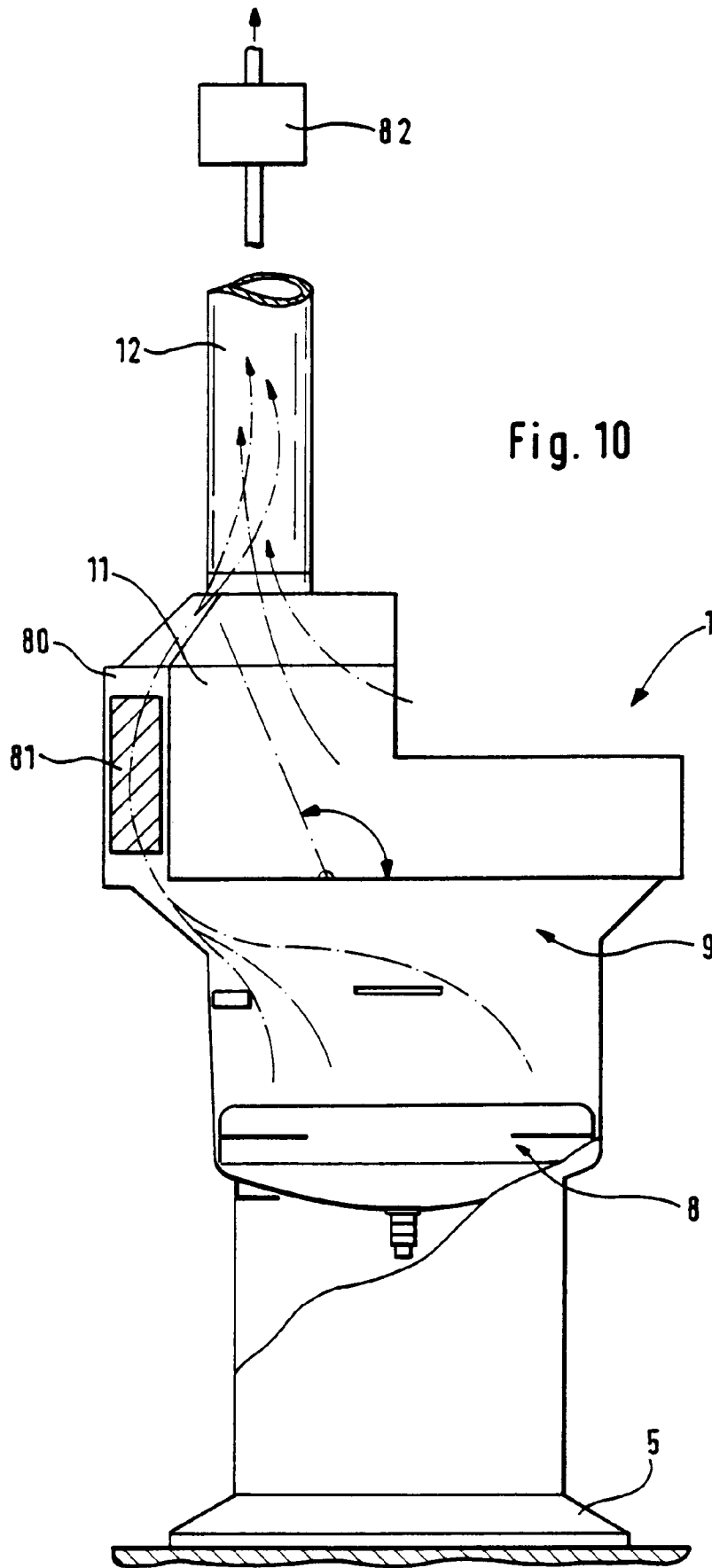

Fig. 9



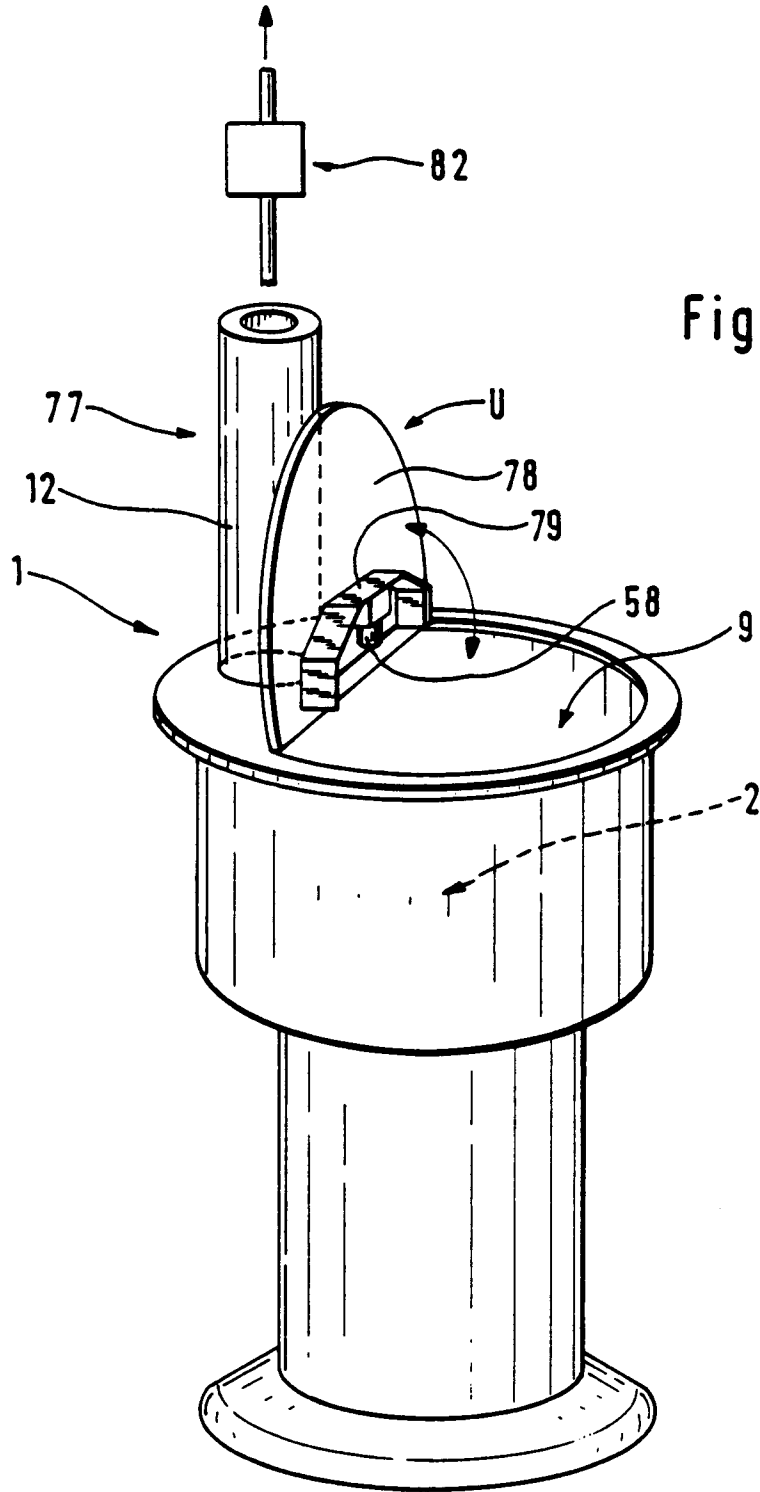

Fig. 11