

J. FOGARTY.
Steam-Plow.

No. 160,760.

Patented March 16, 1875.

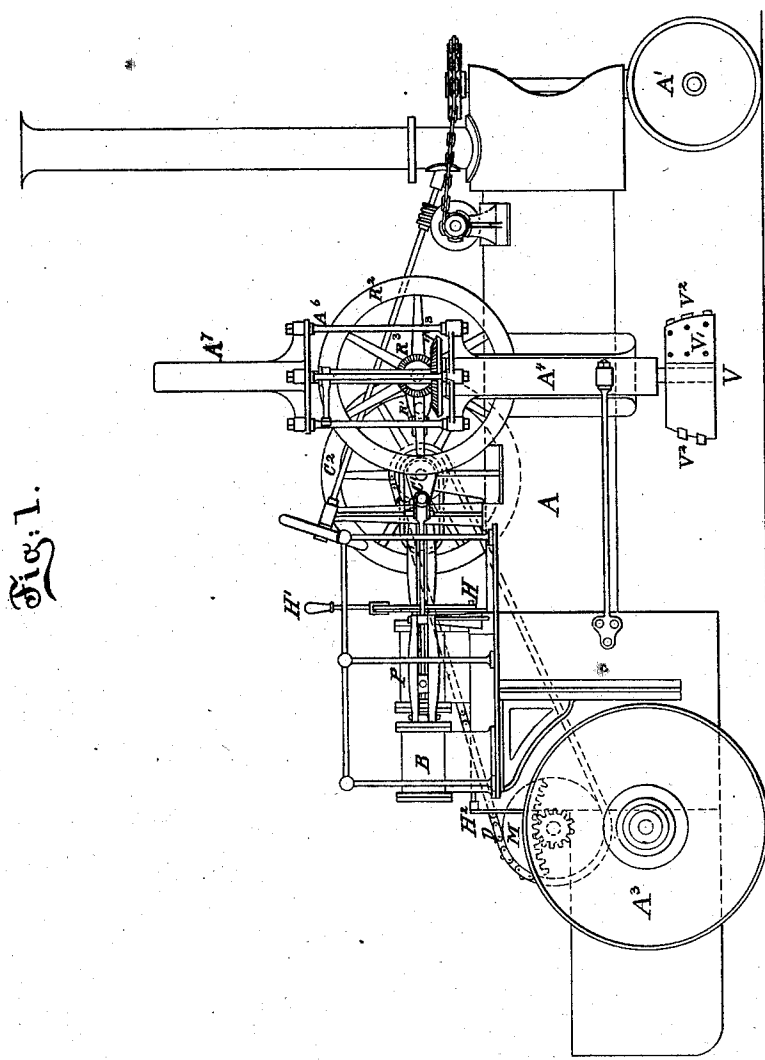

Fig. 1.

Witnesses:

E. Volkmann.

M. C. Dey.

Inventor:

James Fogarty
by his attorney
J. L. G. [Signature]

J. FOGARTY.
Steam-Plow.

No. 160,760.

Patented March 16, 1875.

Fig. 2.

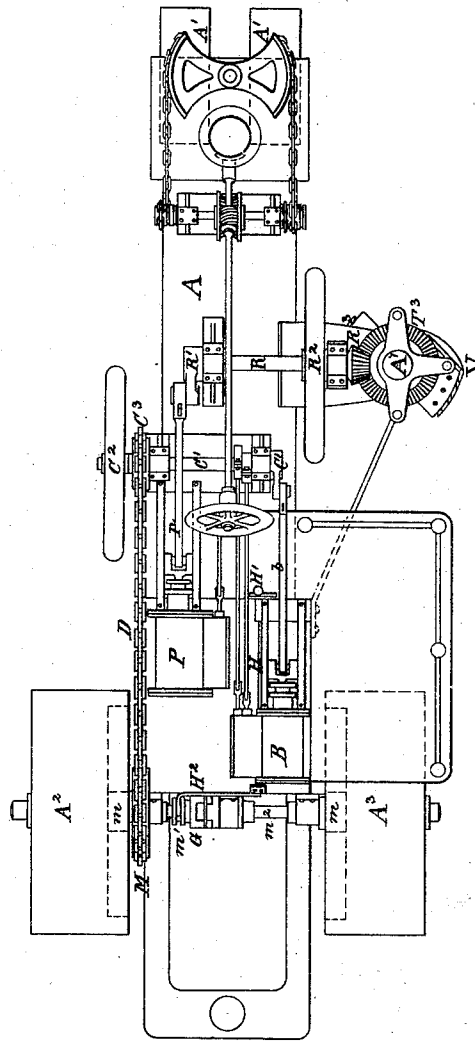

Witnesses:

E. Volkman.

M. C. Dey.

Inventor:

James Fogarty
by his attorney
J. L. Stetson

J. FOGARTY.
Steam-Plow.

No. 160,760.

Patented March 16, 1875.

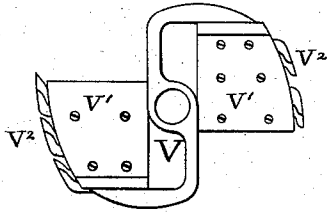

Fig: 5.

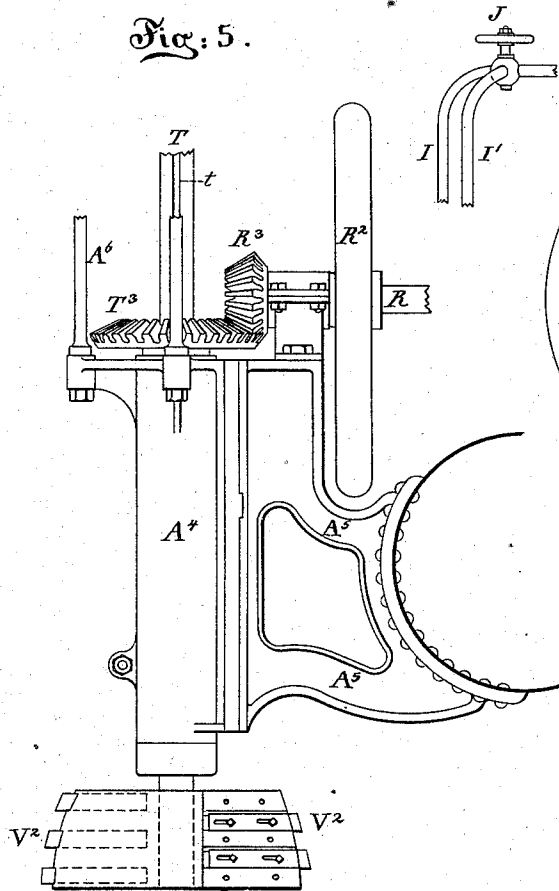

Fig: 4.

Fig: 3.

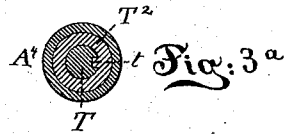
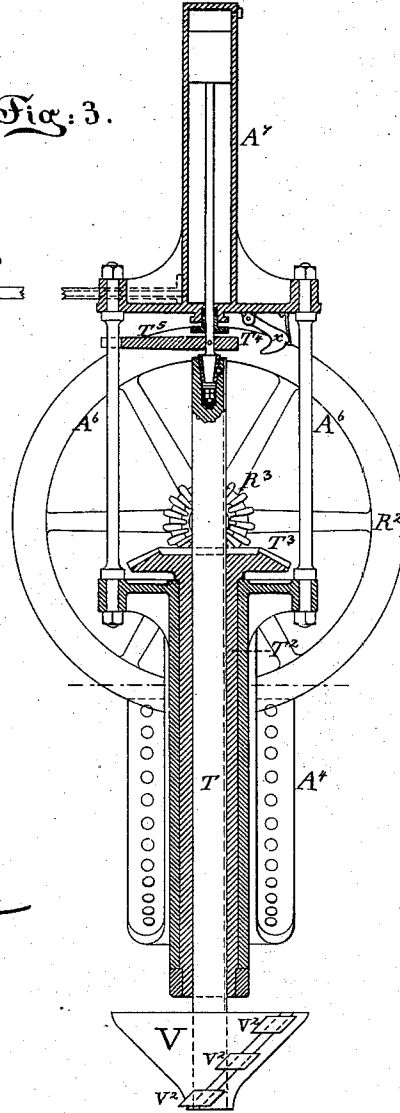

Fig: 3^a

Witnesses:

E. Volkman

W. B. Day

Inventor:

James Fogarty
by his attorney
J. L. Stearns

UNITED STATES PATENT OFFICE.

JAMES FOGARTY, OF NEWARK, NEW JERSEY.

IMPROVEMENT IN STEAM-PLOWS.

Specification forming part of Letters Patent No. 160,760, dated March 16, 1875; application filed October 10, 1874.

To all whom it may concern:

Be it known that I, JAMES FOGARTY, of Newark, in the county of Essex and State of New Jersey, have invented certain Improvements in Steam-Plows, of which the following is a specification:

My improved machine is of that class in which the plowing is effected by a rotating shaft, mounted in the structure and turned by the power thereof, which acts directly upon the earth as it is slowly moved along by its driving-wheels.

I employ a separate engine to drive the rotary cutter, which I will call the plow-shaft, from that which moves the structure forward. The speed of one can be made to bear any desired relation to the speed of the other, and the ratio may be changed at will, as desired.

My plow-shaft is upright, and the cutters are peculiarly adapted to act efficiently in a soil free from stones or other obstructions. It is adapted to act with a rapid rotation.

The plow-shaft is raised and lowered by admitting water or steam from the boiler under a piston, which is connected so as to support the plow-shaft efficiently and allow the depth of plowing to be instantly varied at will.

The following is a description of what I consider the best means of carrying out the invention.

The accompanying drawings form a part of this specification.

Figure 1 is a side elevation, and Fig. 2 is a plan view, showing all the principal parts. The remaining figures show certain details on a larger scale. Fig. 3 is an elevation, partly in section. It represents the plow-shaft and the parts directly connected. Fig. 3^a is a horizontal section. Fig. 4 is an elevation of the lower portion thereof at right angles to the view in Fig. 3. Fig. 5 is a plan view of the cutters alone.

Similar letters of reference indicate like parts in all the figures.

A is what may be called the fixed frame-work or body of the machine, composed of a boiler and such bracing and supporting frame-work as may be necessary to properly sustain the other parts. The axle of the front wheels A¹ A¹ is swiveled by means of the train of mechanism represented, operated by a hand-wheel to steer the machine. The

larger hind wheels A² A³ are mounted loosely on a fixed axle. Each is formed with internal gearing, through which motion is communicated to each wheel independently by means of mechanism to be described, and which allows one to be driven while the other stands still. B is a steam-cylinder, having suitable connections for the steam and provisions for working the valves, &c. Its piston is connected through the rod *b* to a crank, C¹, on the shaft C, which is provided with a fly-wheel, C², and with a wheel, C³, of the character sometimes denominated a sprocket-wheel or pitch-wheel, which gives motion, through the pitch-chain D, to a corresponding pitch-wheel, M, on one of two short shafts, *m*¹ *m*², abutting end to end in the center line of the machine. On each of these short shafts *m*¹ *m*² is a small pinion, *m*, engaging in the internal gear of its respective wheel A² or A³. When steam is admitted to the cylinder B, and, consequently, this train of mechanism is worked, the wheel A² is directly impelled thereby. The other wheel, A³, may or may not be impelled, according as the position of the clutch-piece G is adjusted. This piece G is feathered or splined to the shaft *m*¹, being moved laterally by the light arm H², fixed on the longitudinal shaft H, and operated by the handle H¹. It moves into or out of engagement with a corresponding clutch-piece on the shaft *m*², the pinion on which drives the wheel A³. P is the steam-cylinder of an entirely independent engine and mechanism which operates the plows. The piston of this engine is connected, through the rod *p*, with the crank R¹ on the shaft R, which carries a fly-wheel, R², and a beveled gear-wheel, R³. This latter engages with a beveled gear-wheel, T³, which is fixed on a sleeve, T², connected by a loose spline-key or feather, *t*, with a shaft, T. This latter is compelled to turn with the sleeve T², but may be depressed and raised through it to a sufficient height to allow all the variations of depth of plowing, and also to allow the plow to be lifted entirely clear of the ground, when required.

What I term the "plow" is a revolving instrument, designated generally by the single letter V, the several parts being designated V¹ V², &c., when necessary. Two broad inclined plates, V¹, are mounted in a proper

position to seize and lift the earth as the shaft T is revolved. Under each plate V¹ are two or more rectangular grooves, which receive the bodies of the teeth V². The points or cutting ends of these teeth are bent upward and forward, and the teeth being secured by screw-bolts inserted through slots in the bodies, they may be adjusted outward or inward, as required. The bolts which hold the teeth V² have thin heads, which are accommodated under the plates V¹. The latter may be held by bolts with countersunk heads. I esteem it important that the faces of the plates V¹ shall be smooth, and adapted to dig into and lift the earth with as little resistance as may be.

The sleeve T² is inclosed within a stout framing-piece, A⁴, which is stiffly supported by one or more braces, A⁵. The upper end of this piece A⁴ is connected, by rigid uprights A⁶, to the broad extended foot of the long cylinder A⁷. This latter performs an important function in lifting and adjusting the elevation of the plow. Its interior is provided with a piston suitably packed, to be raised by the pressure of water from below. The piston-rod moves through a stuffing-box at the lower end thereof. A pipe, I, leads from near the lower end of this cylinder A⁷ to a point below the water-line of the boiler, and the communication through it is controlled by a three-way cock, J, within convenient reach of the engineer. When this cock J is adjusted in one position it allows the water from the boiler, under the full pressure therein, to flow through the pipe I into the cylinder, and it commences to slowly raise the plow-shaft and its connections.

Steam may be admitted instead of water by making the connection above the water-line; but I prefer a water-connection, in order that the motion may be moderate, and to avoid any change of position by condensation of the fluid after the proper elevation is attained.

Putting the cock J in one position completely stops the flow in either direction through the pipe I, and holds the plow at a fixed elevation. Changing the cock J into a third position allows the water to flow out through the pipe I and a connection, I', which latter discharges it into the atmosphere. A small orifice is provided, near the top of the cylinder A⁷, properly provided against the admission of dirt, to allow the air to enter and escape. A hook, x, with means for suspending it out of the way, is provided for engaging, under a collar, T⁴, for holding the plow at its highest elevation, when required, for a long period, as in the migration of the machine from one portion of the farm or plantation to another. An arm, T⁵, extending from the collar T⁴, takes hold, by a fork at its extremity, on one of the smooth upright rods which support the cylinder, and serves as a guide to prevent the piston and its rod from being turned with the rotation of the plow-shaft.

The connection between the rotating plow-

shaft and the non-rotating piston-rod may be formed in the same manner as in the well-known suspended centrifugal sugar-drainer, where a collar on the non-rotating part holds up a series of washers inclosed below a tapering plug keyed in the upper end of the revolving shaft.

Many of the details may be modified in the forms and proportions. It is desirable to make the whole apparatus light; but I prefer not to sacrifice strength and durability, either in the propelling or in the plowing mechanism.

The lower edge of each plate V¹, as well as the outer edge or periphery, may have adjustable teeth, as shown by V²; but I do not esteem it as important there, because the motion is less. The outer edge is subjected to severe wear in cutting rapidly and steadily through the soil. Whenever it is found that the teeth have become in any considerable degree dulled they may be sharpened by grinding and resetting. When the bent portion is too much used up the blacksmith's skill readily bends and hardens a fresh quantity of metal, and the tooth is again in order as before. The teeth V² should be of cast-steel. The plates V¹ may be of inferior metal.

In operation, the engineer on the platform may hold at the same time two handles, and which control, respectively, the operation of the propelling and plowing mechanism. The propelling should have a Stevenson link motion, or other means for reversing. A connection may be made from the cock J, or an equivalent valve, to be operated by the foot, so that the engineer need not let go of either of the handles to change the elevation of the plow. In mellow alluvial soils free from stones it will not usually be necessary to change the elevation of the plow except at long intervals. I propose, in some cases, to widen the bent cutting-ends of the teeth V², so as to produce a continuous bent cutting-edge in separate adjustable pieces.

I claim as my invention—

1. The rotating plow V, having the inclined plates V¹ and teeth V², combined and adapted to serve as and for the purposes herein specified.

2. In a steam-plow, the independent steam-cylinders B P, with their respective trains of mechanism, combined and adapted, the one to impel the revolving plow, and the other the propelling-wheels, with variable ratios of power and velocity, as specified.

3. In combination with the plow-shaft T and its propelling mechanism, the connected piston and cylinder A⁷, with the controlling-valve J, to allow the plows to be raised and lowered at will, in the manner herein set forth.

In testimony whereof I have hereunto set my hand this 7th day of October, 1874, in the presence of two subscribing witnesses.

JAMES FOGARTY.

Witnesses:

WM. C. DEY,
E. VOLKMANN.