



(86) **Date de dépôt PCT/PCT Filing Date:** 2008/02/08
 (87) **Date publication PCT/PCT Publication Date:** 2008/08/21
 (45) **Date de délivrance/Issue Date:** 2016/06/21
 (85) **Entrée phase nationale/National Entry:** 2009/06/26
 (86) **N° demande PCT/PCT Application No.:** US 2008/001741
 (87) **N° publication PCT/PCT Publication No.:** 2008/100446
 (30) **Priorité/Priority:** 2007/02/09 (US60/900,415)

(51) **Cl.Int./Int.Cl. A61M 27/00** (2006.01),
A61M 1/00 (2006.01)
 (72) **Inventeurs/Inventors:**
 SANDERS, BLANE, US;
 HEATON, KEITH, PATRICK, GB;
 HARDMAN, IAN, JAMES, GB;
 LOCKE, CHRISTOPHER, BRIAN, GB;
 ROBINSON, TIMOTHY, MARK, GB;
 BEARD, MARK STEPHAN, JAMES, GB;
 JAEB, JONATHAN, PAUL, US;
 ...

(73) **Propriétaire/Owner:**
 KCI LICENSING INC., US

(74) **Agent:** BORDEN LADNER GERVAIS LLP

(54) **Titre : APPAREIL ET PROCEDE D'ADMINISTRATION D'UN TRAITEMENT PAR PRESSION REDUITE SUR UN SITE TISSULAIRE**

(54) **Title: APPARATUS AND METHOD FOR ADMINISTERING REDUCED PRESSURE TREATMENT TO A TISSUE SITE**

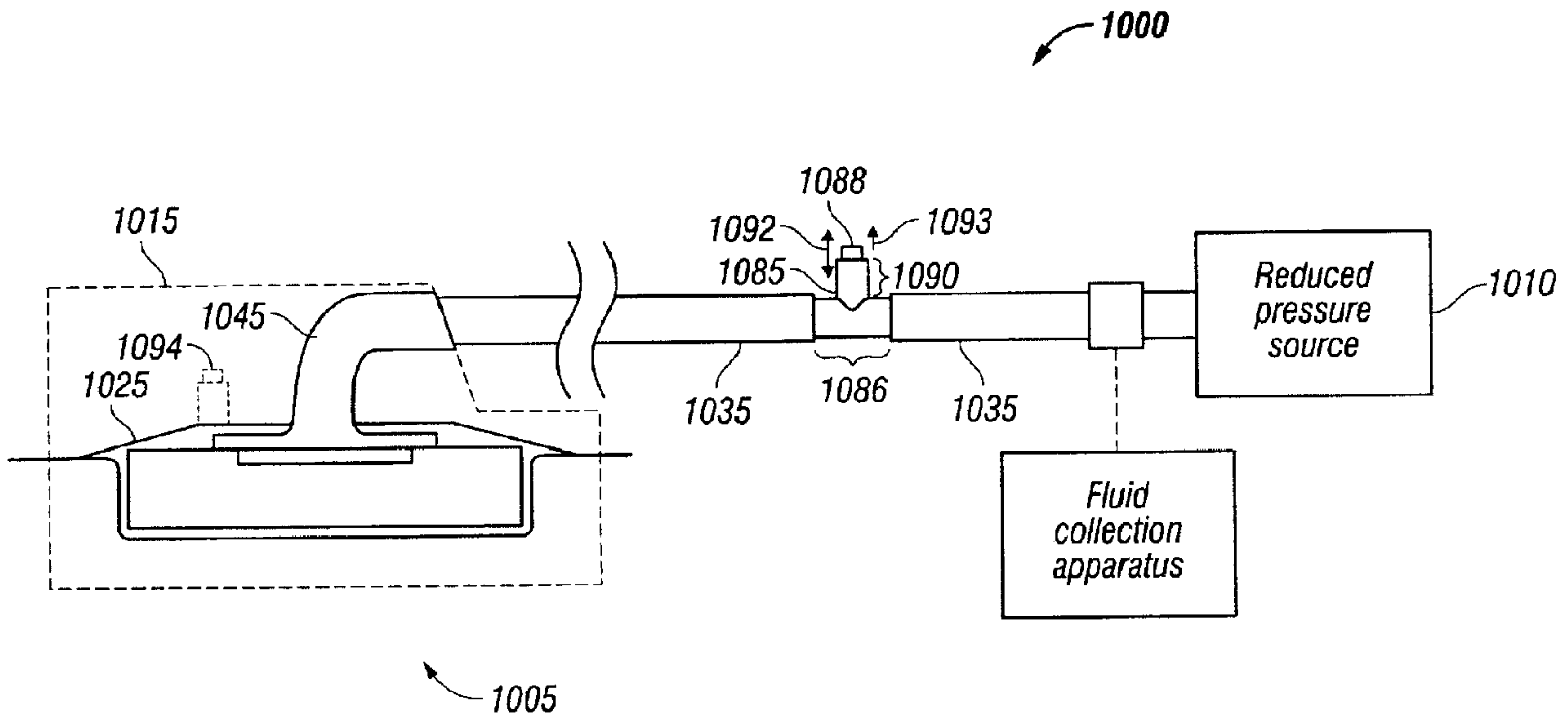

(57) **Abrégé/Abstract:**

The illustrative embodiments described herein are directed to a system and method for administering reduced pressure at a tissue site. The apparatus includes a reduced pressure source. The reduced pressure source generates a reduced pressure. The apparatus includes a tube having a plurality of lumens. The plurality of lumens includes at least one collection lumen. The reduced pressure source applies the reduced pressure to the tissue site through the plurality of lumens such that the at least one collection lumen receives fluid from the tissue site. The at least one collection lumen stores the fluid received from the tissue site.

(72) **Inventeurs(suite)/Inventors(continued)**: KIESWETTER, KRISTINE, US; JOHNSON, ROYCE, W., US;
INGRAM, SHANNON, C., US

(12) INTERNATIONAL APPLICATION PUBLISHED UNDER THE PATENT COOPERATION TREATY (PCT)

(19) World Intellectual Property Organization
International Bureau(43) International Publication Date
21 August 2008 (21.08.2008)

PCT

(10) International Publication Number
WO 2008/100446 A3

(51) International Patent Classification:

A61M 1/00 (2006.01)

(21) International Application Number:

PCT/US2008/001741

(22) International Filing Date: 8 February 2008 (08.02.2008)

(25) Filing Language:

English

(26) Publication Language:

English

(30) Priority Data:

60/900,415 9 February 2007 (09.02.2007) US

(71) Applicant (for all designated States except US): KCI LICENSING INC. [US/US]; Legal Department - Intellectual Property, P.O. Box 659508, San Antonio, TX 78265-9508 (US).

(72) Inventors; and

(75) Inventors/Applicants (for US only): SANDERS, Blane [US/US]; 702 Stone Way, San Antonio, TX 78258 (US). HEATON, Keith, Patrick [GB/GB]; 3 Clifton Road, Penn Hill, Poole, Dorset BH14 9PW (GB). HARDMAN, Ian, James [GB/GB]; 74 Victoria Avenue, Bournemouth, Dorset BH9 2RP (GB). LOCKE, Christopher, Brian [GB/GB]; 6 Bosworth Mews, Bournemouth, Dorset BH9 3SD (GB). ROBINSON, Timothy, Mark [GB/GB];

27 Wellington Terrace, Basingstoke, Hampshire RG23 8HH (GB). BEARD, Mark Stephan, James [GB/GB]; 4 Monks Close, West Moors, Ferndown, Dorset BH22 OHE (GB). JAEB, Jonathan, Paul [US/US]; 27651 Ranch Lane, Boerne, TX 78006 (US). KIESWETTER, Kristine [US/US]; 426 Mission Street, San Antonio, TX 78210 (US). JOHNSON, Royce, W. [US/US]; 114 Rindale, Universal City, TX 78148 (US). INGRAM, Shannon, C. [US/US]; 30155 Bridlegate Drive, Bulverde, TX 78163 (US).

(74) Agents: MASON, Robert, W. et al.; Kinetic Concepts, Inc., P.O.Box 659508, San Antonio, TX 78265-9508 (US).

(81) Designated States (unless otherwise indicated, for every kind of national protection available): AE, AG, AL, AM, AO, AT, AU, AZ, BA, BB, BG, BH, BR, BW, BY, BZ, CA, CH, CN, CO, CR, CU, CZ, DE, DK, DM, DO, DZ, EC, EE, EG, ES, FI, GB, GD, GE, GH, GM, GT, HN, HR, HU, ID, IL, IN, IS, JP, KE, KG, KM, KN, KP, KR, KZ, LA, LC, LK, LR, LS, LT, LU, LY, MA, MD, ME, MG, MK, MN, MW, MX, MY, MZ, NA, NG, NI, NO, NZ, OM, PG, PH, PL, PT, RO, RS, RU, SC, SD, SE, SG, SK, SL, SM, SV, SY, TJ, TM, TN, TR, TT, TZ, UA, UG, US, UZ, VC, VN, ZA, ZM, ZW.

(84) Designated States (unless otherwise indicated, for every kind of regional protection available): ARIPO (BW, GH, GM, KE, LS, MW, MZ, NA, SD, SL, SZ, TZ, UG, ZM,

[Continued on next page]

(54) Title: APPARATUS AND METHOD FOR ADMINISTERING REDUCED PRESSURE TREATMENT TO A TISSUE SITE

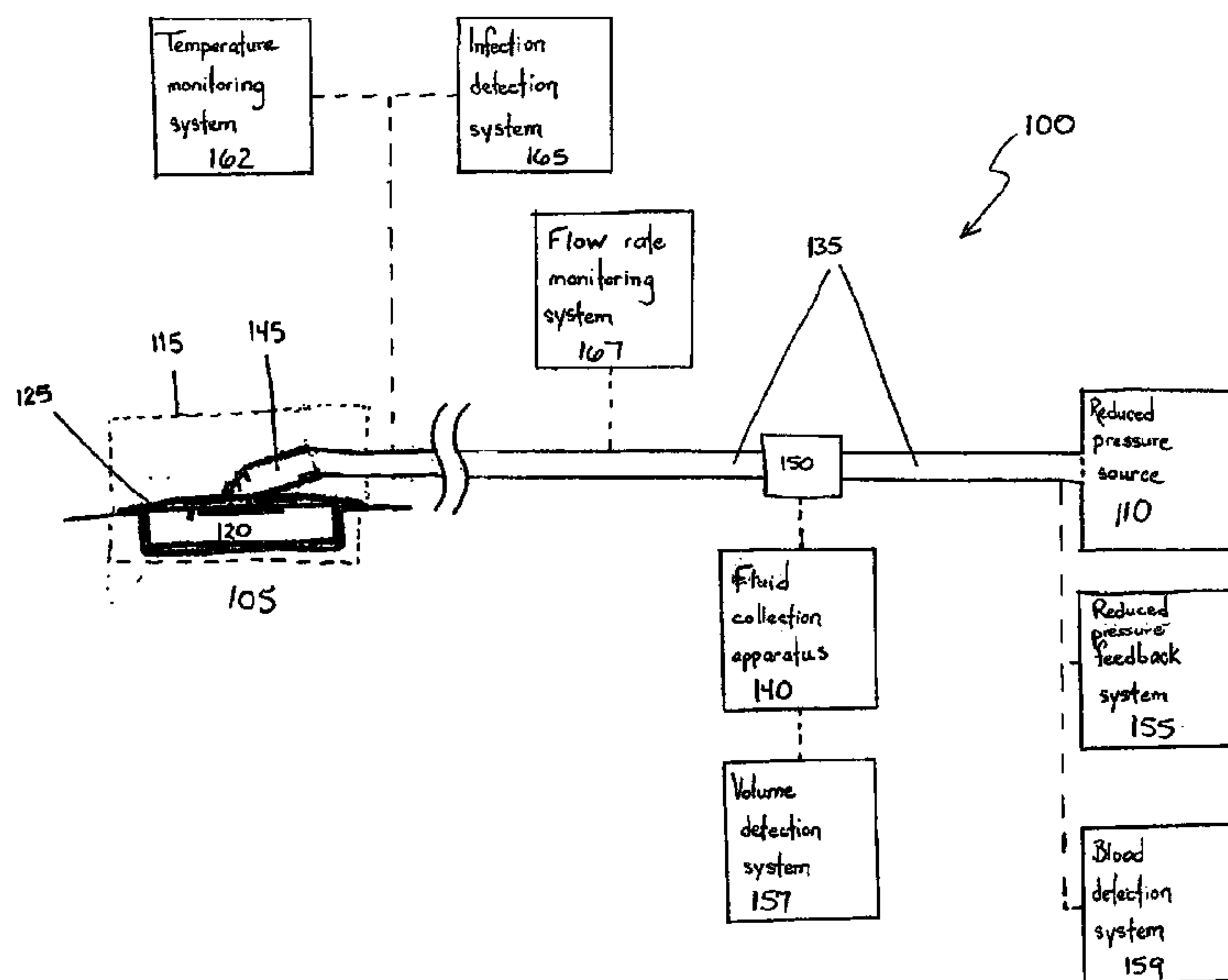

Fig. 1

(57) Abstract: The illustrative embodiments described herein are directed to a system and method for administering reduced pressure at a tissue site. The apparatus includes a reduced pressure source. The reduced pressure source generates a reduced pressure. The apparatus includes a tube having a plurality of lumens. The plurality of lumens includes at least one collection lumen. The reduced pressure source applies the reduced pressure to the tissue site through the plurality of lumens such that the at least one collection lumen receives fluid from the tissue site. The at least one collection lumen stores the fluid received from the tissue site.

WO 2008/100446 A3

WO 2008/100446 A3



ZW), Eurasian (AM, AZ, BY, KG, KZ, MD, RU, TJ, TM),
European (AT, BE, BG, CH, CY, CZ, DE, DK, EE, ES, FI,
FR, GB, GR, HR, HU, IE, IS, IT, LT, LU, LV, MC, MT, NL,
NO, PL, PT, RO, SE, SI, SK, TR), OAPI (BF, BJ, CF, CG,
CI, CM, GA, GN, GQ, GW, ML, MR, NE, SN, TD, TG).

Published:

— *with international search report*

(88) Date of publication of the international search report:

23 October 2008

Declaration under Rule 4.17:

— *as to applicant's entitlement to apply for and be granted a
patent (Rule 4.17(ii))*

APPARATUS AND METHOD FOR ADMINISTERING REDUCED PRESSURE TREATMENT TO A TISSUE SITE

BACKGROUND OF THE INVENTION

1. Field of the Invention

The present invention relates generally to the field of tissue treatment, and more specifically to a system and method for applying reduced pressure at a tissue site.

2. Description of Related Art

Clinical studies and practice have shown that providing a reduced pressure in proximity to a tissue site augments and accelerates the growth of new tissue at the tissue site. The applications of this phenomenon are numerous, but application of reduced pressure has been particularly successful in treating wounds. The treatment of wounds using reduced pressure is sometimes referred to in the medical community as “negative pressure tissue treatment,” “reduced pressure therapy,” or “vacuum therapy.” This type of treatment provides a number of benefits, including faster healing, and increased formulation of granulation tissue.

Reduced pressure treatment systems are often applied to large, highly exudating wounds present on patients undergoing acute or chronic care, as well as other severe wounds that are not readily susceptible to healing without application of reduced pressure. Low-severity wounds that are smaller in volume and produce less exudate have generally been treated using advanced dressings instead of reduced pressure treatment.

Currently, the use of reduced pressure treatment is not considered a viable or affordable option for low-severity wounds due to the manpower required to monitor and change system components, the requirement for trained medical personnel overseeing treatment, and the high cost of treatment. For example, the complexity of current reduced pressure treatment systems precludes a person with little or no specialized knowledge from administering such treatment to oneself or others. The size and power consumption characteristics of current reduced pressure treatment systems also limit the mobility of both the treatment system and the person to whom the treatment is being applied. Also, the high cost of current reduced pressure treatment systems can preclude the accessibility of such treatment systems to some users. Current reduced pressure treatment systems are also typically non-disposable after each treatment.

For example, current reduced pressure treatment systems require the use of a separate fluid container for the storage of exudate that is extracted from the tissue site. However, the inclusion of the added component of a fluid container increases the obtrusiveness, complexity, and weight of the reduced pressure treatment system, thereby increasing the discomfort and limiting the mobility of the patient.

Current reduced pressure treatment systems also lack user-friendly, non-obtrusive methods for indicating whether an adequate amount of reduced pressure is being applied to the tissue site by the reduced pressure treatment system. Therefore, persons with specialized knowledge are required in order to properly operate the reduced pressure treatment system, thereby increasing the cost and decreasing the accessibility of using the reduced pressure treatment system.

While reduced pressure could be applied to low-volume and low-exudating wounds using traditional reduced pressure treatment systems, a need exists for a more simple system that allows reduced pressure treatment to be administered without specialized medical training. A need further exists for a system that uses little power and is compact, allowing a user of the system to remain mobile and participate in normal day-to-day activities. Finally, a system is needed that is inexpensive so that the system can economically be used by a single patient and then disposed of following the end of treatment for that patient.

BRIEF SUMMARY OF THE INVENTION

To alleviate the existing problems with reduced pressure treatment systems, the illustrative embodiments described herein are directed to an apparatus and method for administering reduced pressure at a tissue site. The apparatus includes a reduced pressure source. The reduced pressure source generates a reduced pressure. The apparatus includes a tube having a plurality of lumens. The plurality of lumens includes at least one collection lumen. The reduced pressure source applies the reduced pressure to the tissue site through the plurality of lumens such that the at least one collection lumen receives fluid from the tissue site. The at least one collection lumen stores the fluid received from the tissue site.

In another embodiment, the apparatus includes an indicator that is movable into a plurality of positions. In this embodiment, the indicator moves into a retracted position in the plurality of positions in a presence of reduced pressure from the reduced pressure source. The apparatus may also include a compressible member coupled to the indicator. The compressible member exerts a biasing force on the indicator toward an extended position in the plurality of positions. Other objects, features, and advantages of the invention will become apparent with reference to the drawings, detailed description, and claims that follow.

BRIEF DESCRIPTION OF THE DRAWINGS

Figure 1 is a block diagram of an apparatus for administering reduced pressure at a tissue site in accordance with an illustrative embodiment of the present invention;

Figure 2 is a block diagram of an apparatus for administering reduced pressure at a tissue site in accordance with an illustrative embodiment of the present invention;

Figure 3 is a cross-sectional view of components of an apparatus for administering reduced pressure at a tissue site in accordance with an illustrative embodiment of the present invention;

Figure 4 is a cross-sectional view of components of an apparatus for administering reduced pressure at a tissue site in accordance with an illustrative embodiment of the present invention;

Figure 5 is a cross-sectional view of components of an apparatus for administering reduced pressure at a tissue site in accordance with an illustrative embodiment of the present invention;

Figure 6 is a cross-sectional view of components of an apparatus for administering reduced pressure at a tissue site in accordance with an illustrative embodiment of the present invention;

Figure 7 is a cross-sectional view of components of an apparatus for administering reduced pressure at a tissue site in accordance with an illustrative embodiment of the present invention;

Figure 8 is a cross-sectional view of components of an apparatus for administering reduced pressure at a tissue site in accordance with an illustrative embodiment of the present invention;

Figure 9 is a cross-sectional view of components of an apparatus for administering reduced pressure at a tissue site in accordance with an illustrative embodiment of the present invention;

Figure 10 is a block diagram of an apparatus for administering reduced pressure at a tissue site in accordance with an illustrative embodiment of the present invention;

Figure 11 is a perspective view of components of an apparatus for administering reduced pressure at a tissue site in accordance with an illustrative embodiment of the present invention;

Figure 12 is a perspective view of components of an apparatus for administering reduced pressure at a tissue site in accordance with an illustrative embodiment of the present invention;

Figure 13 is a perspective view of components of an apparatus for administering reduced pressure at a tissue site in accordance with an illustrative embodiment of the present invention;

Figure 14 is graphical representation of a system for administering reduced pressure at a tissue site in accordance with an illustrative embodiment of the present invention;

Figure 15 is a flowchart illustrating a process for administering reduced pressure at a tissue site in accordance with an illustrative embodiment of the present invention; and

Figure 16 is a flowchart illustrating a process for administering reduced pressure at a tissue site in accordance with an illustrative embodiment of the present invention.

DETAILED DESCRIPTION OF THE PREFERRED EMBODIMENT

In the following detailed description of the preferred embodiments, reference is made to the accompanying drawings that form a part hereof, and in which is shown by way of illustration specific preferred embodiments in which the invention may be practiced. The scope of the claims should not be limited by the embodiments set forth in the examples, but should be given the broadest interpretation consistent with the description as a whole. To avoid detail not necessary to enable those skilled in the art to practice the invention, the description may omit certain information known to those skilled in the art. The following detailed description is, therefore, not to be taken in a limiting sense, and the scope of the present invention is defined only by the appended claims.

The illustrative embodiments described herein provide an apparatus and method for administering reduced pressure to a tissue site. Reduced pressure generally refers to a pressure less than the ambient pressure at a tissue site that is being subjected to treatment. In most cases, this reduced pressure will be less than the atmospheric pressure of the location at which the patient is located. Although the terms "vacuum" and "negative pressure" may be used to describe the pressure applied to the tissue site, the actual pressure applied to the tissue site may be significantly less than the pressure normally associated with a complete vacuum.

Consistent with this nomenclature, an increase in reduced pressure or vacuum pressure refers

to a relative reduction of absolute pressure, while a decrease in reduced pressure or vacuum pressure refers to a relative increase of absolute pressure. Similarly, a reduced pressure that is “less” than a particular reduced pressure refers to an absolute pressure that is more than the absolute pressure that corresponds to the particular reduced pressure. Also, a reduced pressure that is “more” than a particular reduced pressure refers to an absolute pressure that is less than the absolute pressure that corresponds to the particular reduced pressure.

The apparatus may include a reduced pressure source. The reduced pressure source generates a reduced pressure. In one embodiment, the apparatus includes a tube having a plurality of lumens. The plurality of lumens includes at least one collection lumen. The reduced pressure source applies the reduced pressure to the tissue site through the plurality of lumens such that the at least one collection lumen receives fluid from the tissue site. The at least one collection lumen stores the fluid received from the tissue site.

In another embodiment, the apparatus includes an indicator that is movable into a plurality of positions. For example, the indicator may be a cylindrical indicator contained in an indicator housing that is coupled between two portions of a delivery tube. The delivery tube may be used to deliver reduced pressure to a tissue site. In one example, the indicator moves into a retracted position in the plurality of positions in a presence of reduced pressure from the reduced pressure source. A compressible member may be coupled to the indicator. As used herein, the term “coupled” includes coupling via a separate object. For example, the compressible member may be coupled to the indicator if both the set of filters and the tube are coupled to a third object. The term “coupled” also includes “directly coupled,” in which case the two objects touch each other in some way. The term “coupled” also encompasses two or more components that are continuous with one another by virtue of each of the components being formed from the same piece of material. The compressible member may exert a biasing force on the indicator toward an extended position in the plurality of positions.

Turning now to Figure 1, a reduced pressure treatment system 100, which applies reduced pressure to a tissue site 105, is shown according to an illustrative embodiment. Tissue site 105 may be the bodily tissue of any human, animal, or other organism, including bone tissue, adipose tissue, muscle tissue, dermal tissue, vascular tissue, connective tissue, cartilage, tendons, ligaments, or any other tissue. While tissue site 105 may include a wound, diseased tissue, or defective tissue, the tissue site may also be healthy tissue that is not wounded, diseased, or defective. The application of reduced pressure to tissue site 105 may be used to promote the drainage of exudate and other liquids from tissue site 105, as well as stimulate the

growth of additional tissue. In the case in which tissue site 105 is a wound site, the growth of granulation tissue and removal of exudates and bacteria promotes healing of the wound. The application of reduced pressure to non-wounded or non-defective tissue, including healthy tissue, may be used to promote the growth of tissue that may be harvested and transplanted to another tissue location.

The reduced pressure that is applied to tissue site 105 is generated by a reduced pressure source 110. Reduced pressure source 110 may be any type of manually, mechanically, or electrically operated pump. Non-limiting examples of reduced pressure source 110 include devices that are driven by stored energy, and which are capable of producing a reduced pressure. Examples of such stored energy, reduced pressure sources include, without limitation, pumps driven by piezo electric energy, spring energy, solar energy, kinetic energy, energy stored in capacitors, combustion, and energy developed by Sterling or similar cycles. Other examples of reduced pressure source 110 include devices that are manually activated, such as bellows pumps, peristaltic pumps, diaphragm pumps, rotary vane pumps, linear piston pumps, pneumatic pumps, hydraulic pumps, hand pumps, foot pumps, and manual pumps such as those used with manually-activated spray bottles. Still other devices and processes that may be used or included in reduced pressure source 110 include syringes, lead screws, ratchets, clockwork-driven devices, pendulum-driven devices, manual generators, osmotic processes, thermal heating processes, and processes in which vacuum pressures are generated by condensation.

In another embodiment, reduced pressure source 110 may include a pump that is driven by a chemical reaction. A tablet, solution, spray, or other delivery mechanism may be delivered to the pump and used to initiate the chemical reaction. The heat generated by the chemical reaction may be used to drive the pump to produce the reduced pressure. In another embodiment, a pressurized gas cylinder such as a CO₂ cylinder is used to drive a pump to produce the reduced pressure. In still another embodiment, reduced pressure source 110 may be a battery-driven pump. Preferably, the pump uses low amounts of power and is capable of operating for an extended period of time on a single charge of the battery.

Reduced pressure source 110 provides reduced pressure to tissue site 105 via a dressing 115. Dressing 115 includes a manifold 120, which may be placed adjacent to or in contact with tissue site 105. Manifold 120 may be a biocompatible, porous material that is capable of being placed in contact with tissue site 105 and distributing reduced pressure to the tissue site 105. Manifold 120 may be made from foam, gauze, felted mat, or any other

material suited to a particular biological application. Manifold 120 may include a plurality of flow channels or pathways to facilitate distribution of reduced pressure or fluids to or from tissue site 105.

In one embodiment, manifold 120 is a porous foam and includes a plurality of interconnected cells or pores that act as flow channels. The porous foam may be a polyurethane, open-cell, reticulated foam such as GranuFoam manufactured by Kinetic Concepts, Inc. of San Antonio, Texas. If an open-cell foam is used, the porosity may vary, but is preferably about 400 to 600 microns. The flow channels allow fluid communication throughout the portion of manifold 120 having open cells. The cells and flow channels may be uniform in shape and size, or may include patterned or random variations in shape and size. Variations in shape and size of the cells of manifold result in variations in the flow channels, and such characteristics may be used to alter the flow characteristics of fluid through manifold 120.

Manifold 120 may also be constructed from bioresorbable materials that do not have to be removed from a patient's body following use of reduced pressure treatment system 100. Suitable bioresorbable materials may include, without limitation, a polymeric blend of polylactic acid (PLA) and polyglycolic acid (PGA). The polymeric blend may also include without limitation polycarbonates, polyfumarates, and caprolactones. Manifold 120 may further serve as a scaffold for new cell-growth, or a scaffold material may be used in conjunction with manifold 120 to promote cell-growth. A scaffold is a substance or structure used to enhance or promote the growth of cells or formation of tissue, such as a three-dimensional porous structure that provides a template for cell growth. Illustrative examples of scaffold materials include calcium phosphate, collagen, PLA/PGA, coral hydroxy apatites, carbonates, or processed allograft materials. In one example, the scaffold material has a high void-fraction (i.e. a high content of air).

Dressing 115 also includes a sealing member 125. Manifold 120 may be secured to tissue site 105 using sealing member 125. Sealing member 125 may be a cover that is used to secure manifold 120 at tissue site 105. While sealing member 125 may be impermeable or semi-permeable, in one example sealing member 125 is capable of maintaining a reduced pressure at tissue site 105 after installation of the sealing member 125 over manifold 120. Sealing member 125 may be a flexible drape or film made from a silicone based compound, acrylic, hydrogel or hydrogel-forming material, or any other biocompatible material that includes the impermeability or permeability characteristics desired for tissue site 105. Sealing

member 125 may be formed of a hydrophobic material to prevent moisture absorption by the sealing member 125.

Instead of being provided in “sheet” form such as that of a drape, sealing member 125 may be provided in a pourable or sprayable form that is applied over the manifold 120 after placement of manifold 120 in contact with the tissue site 105. Similarly, sealing member 125 may include a device that is placed over manifold 120 and tissue site 105 to provide sealing functionality, including but not limited to a suction cup, a molded cast, and a bell jar.

In one embodiment, sealing member 125 is configured to provide a sealed connection with the tissue surrounding manifold 120 and tissue site 105. The sealed connection may be provided by an adhesive positioned along a perimeter of sealing member 125 or on any portion of sealing member 125 to secure sealing member 125 to manifold 120 or the tissue surrounding tissue site 105. The adhesive may be pre-positioned on sealing member 125 or may be sprayed or otherwise applied to sealing member 125 immediately prior to installing sealing member 125.

In some cases, sealing member 125 may not be required to seal tissue site 105. For example, tissue site 105 may be capable of being “self-sealed” to maintain reduced pressure. In the case of subcutaneous and deep tissue wounds, cavities, and fistulas, maintenance of reduced pressure at tissue site 105 may be possible without the use of sealing member 125. Since tissue often encases or surrounds these types of tissue sites, the tissue surrounding the tissue site acts effectively as a sealing member.

The reduced pressure generated by reduced pressure source 110 may be applied to tissue site 105 using a delivery tube 135. Delivery tube 135 may be any tube through which a gas, liquid, gel, or other fluid may flow. For example, exudate from tissue site 105 may flow through delivery tube 135. In Figure 1, connector 150 couples delivery tube 135 to a fluid collection apparatus 140. However, delivery tube 135 may directly couple reduced pressure source 110 to dressing 115 without intervening connector 150 or fluid collection apparatus 140.

Delivery tube 135 may have any cross-sectional shape, such as a circle, oval, or polygon. In addition, delivery tube 135 may be made from any material, and may be either flexible or inflexible. Also, delivery tube 135 may include one or more paths or lumens through which fluid may flow. For example, delivery tube 135 may include two lumens. In this example, one lumen may be used for the passage of exudate from tissue site 105 to fluid collection apparatus 140. The other lumen may be used to deliver fluids, such as air,

antibacterial agents, antiviral agents, cell-growth promotion agents, irrigation fluids, or other chemically active agents, to tissue site 105. The fluid source from which these fluids originate is not shown in Figure 1.

In one embodiment, delivery tube 135 includes a delivery lumen and one or more collection lumens to collect exudate from tissue site 105. These lumens may also each include a filter to manage the flow of exudate through the lumens. Additional details regarding the inclusion of delivery lumens, collection lumens, and filters in delivery tube 135 are provided below in Figures 2-10.

In one embodiment, delivery tube 135 is coupled to manifold 120 via a connection member 145. Connection member 145 permits the passage of fluid from manifold 120 to delivery tube 135, and vice versa. For example, exudates collected from tissue site 105 using manifold 120 may enter delivery tube 135 via connection member 145. In another embodiment, reduced pressure treatment system 100 does not include connection member 145. In this embodiment, delivery tube 135 may be inserted directly into sealing member 125 or manifold 120 such that an end of delivery tube 135 is adjacent to or in contact with manifold 120.

Reduced pressure treatment system 100 includes fluid collection apparatus 140. Liquid, such as exudate, from tissue site 105 may flow through delivery tube 135 into fluid collection apparatus 140. Fluid collection apparatus 140 may be any device or cavity capable of containing a fluid, such as gases and liquids, as well as fluids that contain solids. For example, canister 115 may contain exudates from tissue site 105. Delivery tube 135 may be directly connected to fluid collection apparatus 140, or may be coupled to fluid collection apparatus 140 via a connector, such as connector 150.

The fluid collection apparatus 140 may be a flexible or rigid canister, a bag, or pouch fluidly connected to manifold 120 by delivery tube 135. Fluid collection apparatus 140 may be a separate container or may be operably combined with reduced pressure source 110 to collect exudate and fluids. In an illustrative embodiment in which a manual pump, such as a bellows pump, is used as reduced pressure source 110, the variable-volume chamber that generates the reduced pressure may also serve as fluid collection apparatus 140, collecting fluid as the chamber expands. The fluid collection apparatus 140 may include a single chamber for collecting fluids, or alternatively may include multiple chambers. A desiccant or absorptive material may be disposed within fluid collection apparatus 140 to trap or control fluid once the fluid has been collected. In the absence of fluid collection apparatus 140, a

method for controlling exudate and other fluids may be employed in which the fluids, especially those that are water soluble, are allowed to evaporate from manifold 120. In another embodiment, one or more collection lumens in delivery tube 135, which will be described below in Figure 2-10, may be used in lieu of or in addition to fluid collection apparatus 140.

Reduced pressure treatment system 100 includes a reduced pressure feedback system 155 operably associated with the other components of reduced pressure treatment system 100 to provide information to a user of the reduced pressure treatment system 100 indicating a relative or absolute amount of pressure that is being delivered to the tissue site 105 or that is being generated by reduced pressure source 110. Examples of feedback systems include, without limitation, pop valves that activate when the reduced pressure rises above a selected value and deflection pop valves. Additional details regarding feedback systems that include pop valves and, in particular, movable indicators that respond to reduced pressure in delivery tube 135, are provided below with respect to Figures 11-14.

Other non-limiting examples of feedback systems include low power electronic indicators powered by miniature cells, dial indicators that indicate specific pressure values that are being applied to the tissue site, polymers with various deflection characteristics, and films that move relative to one another to produce visual identifiers indicating the relative or absolute pressure values being generated by the reduced pressure source 110. An example of a "film" based system may include a yellow film anchored to a first part of the reduced pressure source 110 that is capable of movement relative to a blue film anchored to a second part. When the first and second parts are moved relative to one another to apply a reduced pressure, the yellow and blue films overlap to create a green indicator. As the pressure increases and the films move away from one another, the loss of the green color indicates that the pressure has increased (i.e. more reduced pressure needs to be applied).

Reduced pressure treatment system 100 may further include a volume detection system 157 to detect the amount of fluid present in fluid collection apparatus 140, a blood detection system 159 to detect the presence of blood in exudate drawn from tissue site 105, a temperature monitoring system 162 to monitor the temperature of tissue site 105, an infection detection system 165 to detect the presence of infection at tissue site 105, and a flow rate monitoring system 167 to monitor the flow rate of fluids drawn from tissue site 105. Infection detection system 165 may include a foam or other substance that changes color in the presence of bacteria. The foam or other substance may be operably associated with manifold 120 or

delivery tube 135 such that the color changing material is exposed to exudate from tissue site 105. In addition to the above-mentioned components and systems, reduced pressure treatment system 100 may include valves, regulators, switches, and other electrical, mechanical, and fluid components to facilitate administration of reduced pressure treatment to tissue site 105.

Turning now to Figure 2, reduced pressure treatment system 200, which is a non-limiting example of reduced pressure treatment system 100 in Figure 1, is shown according to an illustrative embodiment. In one embodiment, fluid collection apparatus 140 in Figure 1 is tube 235 fluidly connected between the dressing 215 and the reduced pressure source 210. Dressing 215 and reduced pressure source 210 are non-limiting examples of dressing 115 and reduced pressure source 110 in Figure 1, respectively.

Tube 235 includes a plurality of lumens. In particular, tube 235 includes a delivery lumen 270 and a plurality of collection lumens 272. Although Figure 2 shows tube 235 as having a single delivery lumen 270 and two collection lumens 272, tube 235 may have any number of delivery and collection lumens. For example, multiple delivery lumens and a single collection lumen may be included in tube 235.

All of the plurality of lumens in tube 235, including delivery lumen 270 and plurality of collection lumens 272, are fluidly connected to reduced pressure source 210 such that all are exposed to reduced pressure. Thus, reduced pressure generated by reduced pressure source 210 may be transmitted through each of the plurality of lumens in tube 235 to tissue site 205 via dressing 215. In one embodiment, reduced pressure source 210 applies reduced pressure to tissue site 205 through delivery lumen 270 and plurality of collection lumens 272 such that the plurality of collection lumens 272 receives a fluid 274, such as a liquid or a liquid containing solids, from tissue site 205. In one example, fluid 274 is exudate from tissue site 205. Plurality of collection lumens 272 may store fluid 274 received from tissue site 205. Thus, the need for a separate fluid collection apparatus, such as fluid collection apparatus 140 in Figure 1, is eliminated.

Reduced pressure treatment system 200 may include at least one filter coupled to tube 235. In particular, tube 235 includes a delivery lumen filter 276 and collection lumen filter 278. Delivery lumen filter 276 and collection lumen filter 278 prevents fluid 274 from tissue site 205 from passing or flowing past the one or more locations at which the filters are located. Delivery lumen filter 276 and collection lumen filter 278 may be any type of filter capable of preventing the flow of fluid 274, such as a hydrophobic filter, a hydrophilic filter, and a

mechanical valve. In the example in which delivery lumen filter 276 or collection lumen filter 278 is a mechanical valve, a one-way valve, such as a duck-bill valve, may be used.

Delivery lumen filter 276 is coupled to the end of tube 235 that is adjacent to tissue site 205 and dressing 215. As used herein, "adjacent" means at or near another object. In one example, a first object may be adjacent to a particular object if the first object is nearer to the particular object than a second object. Thus, a first end of tube 235 may be adjacent to tissue site 205 if the first end of the tube is nearer to tissue site 205 than a second end of the tube. Delivery lumen filter 276 restrains or prevents fluid 274 from entering delivery lumen 270 through dressing 215. Thus, reduced pressure may continually be applied via delivery lumen 270 unobstructed by fluid 274, even as fluid 274 is collected into plurality of collection lumens 274.

Although Figure 2 shows delivery lumen filter 276 as preventing any fluid 274 from entering delivery lumen 270, delivery lumen filter 276 may also be placed so as to prevent fluid 274 from passing a particular point along delivery lumen 270. For example, delivery lumen filter 276 may be placed inside of delivery lumen 270 at a particular distance away from an end of tube 235 such that fluid 274 is allowed to enter a portion of delivery lumen 270 unobstructed by delivery lumen filter 276. Additional details regarding the placement and coupling of delivery lumen filter 276 is provided in Figures 4-6 below.

Collection lumen filter 278 is coupled to the end of tube 235 that is adjacent to reduced pressure source 210. Collection lumen filter 278 prevents fluid 274 from entering reduced pressure source 210 or from exiting plurality of collection lumens 272. Due to the location of collection lumen filter 278, plurality of collection lumens 272 between the dressing 215 and collection lumen filter 278 are reservoirs capable of receiving exudate and other fluids from tissue site 205. Since plurality of collection lumens 272 are influenced by reduced pressure source 210, fluids are drawn from tissue site 205 through manifold 220, which is adjacent to tissue site 205, into plurality of collection lumens 272. The volume of space available for fluid depends upon the diameter and number of collection lumens in plurality of collection lumens 272, as well as the length of each collection lumen between dressing 215 and collection lumen filter 278. For example, plurality of collection lumens 272 may be capable holding approximately 30-60 cubic centimeters of fluid 274. However, the aforementioned physical parameters of plurality of collection lumens 272 may be adjusted based on the particular implementation such that plurality of collection lumens 272 may store any amount of fluid 274.

As plurality of collection lumens 272 fill with fluid, plurality of collection lumens 272 continue to be capable of transmitting reduced pressure from reduced pressure source 210. When plurality of collection lumens 272 are completely full of fluid 274 between dressing 215 and collection lumen filter 278, reduced pressure may no longer be capable of being transmitted through plurality of collection lumens 272. However, delivery lumen 270 continues to transmit reduced pressure even after the plurality of collection lumens 272 is full.

Although collection lumen filter 278 is shown as being coupled to the end of tube 235 that is adjacent to reduced pressure source 210, collection lumen filter 278 may be located anywhere along tube 235. For example, collection lumen filter 278 may be located at a midpoint along the length of tube 235. In this example, plurality of collection lumens 272 may fill with fluid 274 until fluid 274 becomes obstructed by collection lumen filter 278 at the midpoint of tube 235. Thus, collection lumen filter 278 prevents fluid 274 from passing the midpoint of tube 235 along plurality of collection lumens 272. In this example, only a portion of the space defined by plurality of collection lumens 272 may fill with fluid 274.

In another example, reduced pressure treatment system 200 may include multiple collection lumen filters. In this example, each collection lumen filter may be located at a different location along each collection lumen in plurality of collection lumens 272. Thus, each collection lumen in plurality of collection lumens 272 may have a different fluid capacity.

Because reduced pressure treatment system 200 may be used to treat low-exudating tissue sites, the smaller fluid collection volume provided by plurality of collection lumens 272 (as opposed to a dedicated canister) has little or no effect on the ability of reduced pressure treatment system 200 to provide treatment for an extended period of time. The compact nature of a fluid collection apparatus that is integrated into a reduced pressure delivery tube minimizes patient discomfort and maximizes patient mobility. During treatment, when plurality of collection lumens 272 becomes completely full of fluid 274, tube 235 may be easily replaced with a new tube. To minimize the risk of spilling fluid during tubing changes, or having fluid backflow into manifold 220 during treatment, plurality of collection lumens 272 may be partially filled or packed with desiccants, absorptive materials, or other trapping agents.

In Figure 2, the portion of plurality of collection lumens 272 that contains fluid 274 is shaded to show that fluid 274 is visible to a user of reduced pressure treatment system 200. Tube 235 may include at least one substantially transparent tube portion through which fluid

274 may be visible. For example, the one or more substantially transparent tube portions may be a window on tube 235 made from a transparent material. Each of these windows may extend across portions of tube 235 that are adjacent to each respective collection lumen 272.

In another example, the material from which tube 235 is made may be a transparent material. Thus, fluid 274 may be visible due to the total transparency of tube 235. Because fluid 274 from tissue site 205, such as exudate, may have a darkened color, fluid levels within plurality of collection lumens 272 may be easily ascertainable by a user.

Tube 235 also includes demarcations 280. Demarcations 280 indicate an amount of fluid 274 in plurality of collection lumens 272. In the example in which tube 235 includes one or more substantially transparent tube portions such as transparent windows, demarcations 280 may be included along each the windows. Each of demarcations 280 may correspond to a specific volume or amount of fluid 274. For example, the first of demarcations 280 may be labeled "5 cc" and each demarcation thereafter may be labeled in 5 cubic centimeters increments. The particular incremented used may depend on the implementation.

Turning now to Figure 3, a cross-sectional view of tube 300 is shown from the perspective of cross-sectional indicator labeled "Fig 3" in Figure 2. As shown in Figure 3, delivery lumen 270 has a larger cross-section than each of collection lumens 272. However, in one example, the cross-section of delivery lumen 270 may be the same or smaller than the cross-section of each of collection lumens 272. Delivery lumen 270 and collection lumens 272 also have a circular cross-section shape. However, delivery lumen 270 and collection lumens 272 may have any cross-sectional shape, such as an oval, polygonal, or irregular cross-sectional shape.

Each of collection lumens 272 are shown as equidistant from delivery lumen 270 such that collection lumens 272 surrounds delivery lumen 270 in a circular pattern. However, delivery lumen 270 and collection lumens 272 may have any spatial configuration relative to one another, including configurations in which each of collection lumens 272 are a different distance from delivery lumen 270. In addition, tube 300 may include two or more delivery lumens such as delivery lumen 270. Any number of collection lumens 272 may also be included in tube 300. In one example, the number of delivery lumens in tube 300 exceeds the number of collection lumens.

Delivery lumen 270 is also shown to be located along the longitudinal center of tube 300. However, delivery lumen 270 may be located along any longitudinal axis that traverses the length of tube 300. In one example, delivery lumen 270 and collection lumens 272 may be

defined by walls that longitudinally extend through the length of tube 300. In this example, two or more intersecting walls may define quadrants, any of which may be a delivery lumen or collection lumen.

Turning now to Figure 4, a cross-sectional view of tube 400 is shown from the perspective of cross-sectional indicator labeled "Fig 4" in Figure 2. Tube 400 includes delivery tube filter 276, which is coupled to tube 400 at the opening of delivery lumen 270. Delivery tube filter 276 may have the same or slightly larger cross-section than delivery lumen 270 to ensure the delivery tube filter 276 can prevent fluid from entering delivery lumen 270. Delivery lumen filter 276 may be coupled to the end of tube 400 using any method. For example, delivery lumen filter 276 may be welded, screwed, glued, bolted, air-lock sealed, snapped, or pressed onto the end of tube 400.

Turning now to Figure 5, a cross-sectional view of tube 500 is shown from the perspective of cross-sectional indicator labeled "Fig 5" in Figure 4. Figure 5 shows the opening of delivery lumen 270 obstructed by delivery lumen filter 276 such that fluid from a tissue site cannot enter delivery lumen 270. In particular, delivery lumen filter 276 is shown to be located just outside of delivery lumen 270 such that delivery lumen filter 276 overhangs the diameter of delivery lumen 270 at overhanging portions 277. Delivery lumen filter 276 may have any thickness sufficient to prevent the flow of fluid into delivery lumen 270. The openings of collection lumens 272 are unobstructed by delivery lumen filter 276 such that fluid may be received and collected by collection lumens 272.

Turning now to Figure 6, a cross-sectional view of tube 600 is shown in which delivery lumen filter 276 has a different size and configuration as delivery lumen filter 276 in Figure 5. In particular, delivery lumen filter 276 has a diameter approximately equal to the diameter of delivery lumen 270 such that delivery lumen filter 276 fits into the space defined by delivery lumen 270. Although delivery lumen filter 276 is shown to be positioned at the end of delivery lumen 270, delivery lumen filter 276 may be located anywhere along the length of delivery lumen 270. In this example, delivery lumen filter 276 prevents fluid from a tissue site from passing the location at which delivery lumen filter 276 is located along delivery lumen 270.

Turning now to Figure 7, a cross-sectional view of tube 700 is shown from the perspective of cross-sectional indicator labeled "Fig 7" in Figure 2. Tube 700 includes collection lumen filter 278. Collection lumen filter 278 is shown to be coupled to an end of tube 700. Collection lumen filter 278 is also shown as decoupled from the end of tube 700 to

better show the shape of collection lumen filter. Collection lumen filter 278 is a disk having an aperture 279. When coupled onto the end of tube 700, collection lumen filter 278 covers collection lumens 272 but does not cover delivery lumen 270, as aperture 279 is located at the opening of delivery lumen 270. Thus, collection lumen filter 278 may prevent fluid that has been collected by collection lumen filter 278 from exiting collection lumens 272 and entering a reduced pressure source, such as reduced pressure source 210 in Figure 2. However, reduced pressure may still be applied through collection lumen filter 278 such that collection lumens 272 may transmit reduced pressure to a tissue site. Although collection lumen filter 278 is shown to have an "O" shape, collection lumen filter 278 may have any shape capable of preventing fluid from exiting one or more of collection lumens 272.

Collection lumen filter 278 may be coupled to the end of tube 700 using any method. For example, collection lumen filter 278 may be welded, screwed, glued, bolted, air-lock sealed, snapped, or pressed onto the end of tube 700.

Turning now to Figure 8, a cross-sectional view of tube 500 is shown from the perspective of cross-sectional indicator labeled "Fig 8" in Figure 7. Figure 8 shows the opening of collection lumens 272 obstructed by collection lumen filter 278 such that fluid from a tissue site cannot exit collection lumens 272 or enter a reduced pressure source. In particular, collection lumen filter 278 is shown to be located just outside collection lumens 272 such that collection lumen filter 278 overhangs each diameter of each collection lumen 272. Collection lumen filter 278 may have any thickness sufficient to prevent the flow of fluid out of collection lumens 272. The opening of delivery lumen 270 is unobstructed by collection lumen filter 278 such that no hindrance exists between the opening of delivery lumen 270 and a reduced pressure source

Turning now to Figure 9, a cross-sectional view of tube 900 is shown in which collection lumen filter 278 has a different size and configuration as collection lumen filter 278 in Figure 8. In particular, collection lumen filter 278 includes multiple collection lumen filters, each of which are located inside the space defined by collection lumens 272. The diameter of each collection lumen filter 278 is approximately equal to the diameter of each collection lumen 272 such that collection lumen filters 278 fit into collection lumens 272. In this example, each of collection lumen filters may be mechanical valves that prevent the flow of liquid, such as exudate, but do not prevent the flow of gas, thereby allowing the flow of reduced pressure across collection lumen filters 278. Although collection lumen filters 278 are shown to be positioned at the ends of each collection lumen 272, collection lumen filters

278 may be located anywhere along the length of collection lumens 272, thereby defining a fluid capacity for each collection lumen 272. Each one of collection lumen filter 278 may also be located at different locations along each respective collection lumen 272 such that each collection lumen 272 has a different fluid capacity.

Turning now to Figure 10, reduced pressure treatment system 1000, which is a non-limiting example of reduced pressure system 100 in Figure 1, is shown according to an illustrative embodiment. In particular, reduced pressure treatment system 1000 includes a non-limiting example of reduced pressure feedback system 155 in Figure 1. Reduced pressure treatment system 1000 includes reduced pressure source 1010, which generates a reduced pressure that may be applied to tissue site 1005.

Reduced pressure treatment system 1000 also includes indicator housing 1000, which is disposed between two portions of delivery tube 1035. Delivery tube 1035 is a non-limiting example of delivery tube 135 in Figure 1. Indicator housing 1000 includes connecting portion 1086. Connecting portion 1086 transmits the reduced pressure from one portion of delivery tube 1035 to another portion of delivery tube 1035. Connecting portion 1086 also contains a same or similar amount of reduced pressure as that contained by delivery tube 1035. Indicator housing 1000 includes indicator 1088, which is slidably coupled to an opening along tube portion 1090 of indicator housing 1085. Indicator 1088 may have a cylindrical shape. Indicator 1088 may have an oval or polygonal cross-sectional shape. Indicator 1088 may also be any color, such as red, orange, or yellow.

Indicator 1088 responds to an amount of reduced pressure present in reduced pressure treatment system 1000 such that a user may determine whether a desired or therapeutic amount of reduced pressure is being applied to tissue site 1005. In particular, indicator 1088 is movable into a plurality of positions along axis 1092. The plurality of positions may include a retracted position. In the retracted position, indicator 1088 may be fully or partially retracted into tube portion 1090 such that indicator 1088 is partially or fully non-visible to a user. The plurality of positions may also include an extended position. In Figure 10, indicator 1088 is shown in the extended position. In the extended position, indicator 1088 may be fully or partially protruding from tube portion 1090 such that indicator 1088 is visible by a user. The plurality of positions may also include any position between a fully extended and a fully retracted position.

Reduced pressure treatment system 1000 also includes a compressible member, such as a spring, that is coupled to indicator 1088 and is located in tube portion 1090. The compressible member is not shown in Figure 10, but will be described in greater detail in Figures 11 and 12 below. The compressible member exerts a biasing force on indicator 1088 that biases indicator 1088 toward the extended position. The biasing force is exerted in the direction indicated by arrow 1093.

Although indicator housing 1085 is shown as being disposed between two portions of delivery tube 1035, indicator housing 1085 may be located anywhere in reduced pressure treatment system 1000 at which a reduced pressure being applied to tissue site 1005 may be detected. For example, indicator housing 1085, along with indicator 1088, may be located anywhere at dressing 1015, including sealing member 1025 or connector 1045. Dotted indicator 1094 shows the example in which indicator housing 1085, along with indicator 1088, is located on sealing member 1025. In another example, indicator housing 1085, along with indicator 1088, may be located on either end of a single delivery tube that couples reduced pressure source 1010 to dressing 1015.

In one embodiment, indicator 1088 moves into a retracted position in the presence of reduced pressure from reduced pressure source 1010. In particular, indicator 1088 may move into the retracted position when a reduced pressure is present in delivery tube 1035 and connecting portion 1086. In moving into the retracted position, indicator 1088 must overcome the biasing force being exerted by the compressible member in the direction indicated by arrow 1093. A sufficiently high reduced pressure in connecting portion 1086 may overcome this biasing force and pull indicator 1088 into the retracted position. The amount of reduced pressure that is required to overcome the biasing force may depend on the amount of biasing force exerted by the compressible member. In the example in which the compressible member is a coiled spring, the spring constant of the coiled spring determines the amount of reduced pressure necessary to pull indicator 1088 into the retracted position.

In one example, indicator 1088 moves into the retracted position when the reduced pressure in delivery tube 1035 exceeds a first threshold reduced pressure. The first threshold reduced pressure may be determined by a user and may be implemented by varying the biasing force exerted by the compressible member. For example, a user may select a compressible member with a spring constant that requires the reduced pressure in delivery tube 1035 to exceed a therapeutic reduced pressure in order for indicator 1088 to be pulled into the retracted position. In one embodiment, indicator 1088 moves into the retracted position when an

absolute pressure generated by the reduced pressure source is equal to or less than approximately 125 millimeters of mercury. Thus, a user of reduced pressure treatment system 1000 may be able to visually detect when a therapeutic reduced pressure is being applied to tissue site 1005 by observing that indicator 1088 does not protrude from tube portion 1090.

In another embodiment, the compressible member may bias indicator 1088 into the extended position when the reduced pressure in delivery tube 1035 is less than a second threshold reduced pressure. In one example, the first threshold reduced pressure is the same as the second threshold reduced pressure. In another example, the first threshold reduced pressure is different from the second threshold reduced pressure such that the indicator is in a fully retracted position when the reduced pressure exceeds the first reduced pressure threshold and is in a fully extended position when the reduced pressure is less than the second reduced pressure threshold. In this embodiment, indicator 1088 may be in an intermediate position between the fully retracted and the fully extended position when the reduced pressure is between the first and second reduced pressure thresholds.

In another embodiment, compressible member biases indicator 1088 into the extended position in an absence of reduced pressure in delivery tube 1035. In one example, the absence of reduced pressure is due to reduced pressure source 1010 being turned off. Because the compressible member in tube portion 1090 biases indicator 1088 to protrude from tube portion 1090 when the reduced pressure is absent or below a threshold amount, a user may visually detect when a therapeutic pressure is not being applied to tissue site 1005 by observing that indicator 1088 protrudes from tube portion 1090. The user may then take the necessary action to apply a therapeutic pressure to tissue site 1005. One reason why the reduced pressure in delivery tube 1035 may be absent or below a threshold amount is because of a leak in delivery tube 1035 or elsewhere in reduced pressure treatment system 1000. In this circumstance, a user is alerted to a possible leakage when indicator 1088 is in the extended position.

Turning now to Figure 11, a reduced pressure feedback system 1100, such as that shown in Figure 10, is shown in accordance with an illustrative embodiment. In particular, indicator 1088 is in an extended position in reduced pressure feedback system 1100.

Connecting portion 1086 is slidably engaged with the two portions of delivery tube 1035 to form a sealed fit. Connecting portion 1086 of indicator housing 1085 may also be sealingly engaged with the two portions of delivery tube 1035 in a variety of ways. For example, connecting portion 1086 may be welded, screwed, glued, bolted, air-lock sealed, or snapped to the two portions of delivery tube 1035.

In reduced pressure feedback system 1100, the compressible member is a coiled spring. Tube portion 1090 of indicator housing 1085 includes base 1096, to which an end of coiled spring 1095 is coupled. However, the end of coiled spring 1095 that is not attached to indicator 1088 may be attached to any other component of indicator housing with which a coiled spring maybe used to exert a biasing force on indicator 1088. The inner surface of tube portion 1090 is a tubular opening along which indicator 1088 may slide into retracted and extended positions. Coiled spring 1095 is contained by a plurality of corrugations 1097 that form part of a tubular wall. Corrugations 1097 allow the tubular wall to be compressed and expanded without causing lateral stress to the inner wall of tubular portion 1090.

Reduced pressure feedback system 1100 also includes cap 1098. Cap 1098 may be composed of a transparent material that allows a user to view indicator 1088 when indicator 1088 is in the extended position. In one example, cap 1098 is also sealingly engaged with the remainder of indicator housing 1085 so that reduced pressure does not escape through the tubular opening in indicator housing 1085.

As discussed above, coiled spring 1095 may have any spring constant. The spring constant of coiled spring 1095 determines the biasing force that is exerted upon indicator 1088 toward the extended position. In one embodiment, coiled spring 1095 has a spring constant such that coiled spring 1095 biases indicator 1088 into the extended position when an absolute pressure in delivery tube 1035 exceeds approximately 125 millimeters of mercury. Other coiled springs having other spring constants may also be used to bias indicator 1088 into the extended position when the absolute pressure in delivery tube 1035 exceeds other absolute pressure thresholds, such as desired therapeutic pressure thresholds.

Turning now to Figure 12, reduced pressure feedback system 1200, which is a non-limiting example of reduced pressure feedback system 1100, is shown in accordance with an illustrative embodiment. In particular, reduced pressure feedback system 1200 shows indicator 1088 in a retracted position. When indicator 1088 is in a retracted position, reduced pressure from delivery tube 1035 is transferred to indicator 1088 through the tubular wall formed from corrugations 1097. This reduced pressure exerts a pulling force upon indicator 1088 that is sufficient to overcome the biasing force exerted by coiled spring 1095 in the opposite direction. Indicator 1088 is thus pulled out of transparent cap 1098 and out of the view of a user of the reduced pressure treatment system. The absence of indicator 1088 from cap 1098 indicates to a user that a therapeutic pressure is being administered to the tissue site.

In another embodiment, cap 1098 may be coupled to indicator 1088 such that cap 1098 is also retracted into tube portion 1090 when indicator 1088 is in the retracted position.

Turning now to Figure 13, reduced pressure feedback system 1300, which is a non-limiting example of the reduced pressure feedback system shown in Figure 10, is shown in an illustrative embodiment. The perspective view of Figure 13 shows the circular cross-section of indicator 1088, cap 1098, tube portion 1090, as well as opening 1099 through which indicator 1088 protrudes. These components, however, may have any cross-sectional shape, such as an oval or polygon.

Turning now to Figure 14, a graph showing the relation between the reduced pressure in delivery tube 1035 and the position of indicator 1088 is shown in accordance with an illustrative embodiment. As shown in graph 1400, as the reduced pressure in delivery tube 1035 increases, indicator 1088 moves toward the fully retracted position. In one embodiment, indicator 1088 moves toward the full retracted position in a linear fashion as indicated by graph line 1410. The relation between the reduced pressure and the position of indicator 1088 may also follow other patterns, as indicated by graph lines 1415 and 1420. Other patterns, such as a stair-step pattern, may also characterize the relation between the reduced pressure and the position of indicator 1088. In one example, indicator 1088 is in the fully retracted position when the reduced pressure corresponds to an absolute pressure of 125 millimeters of mercury.

Turning now to Figure 15, a process that may be implemented by a reduced pressure treatment system such as reduced pressure treatment system 200 in Figure 2 is shown in accordance with an illustrative embodiment. The process applies reduced pressure to a tissue site via a plurality of lumens in a delivery tube (step 1505). The process stores fluid from the tissue site in at least one collection lumen in the plurality of lumens (step 1510). The process determines a fluid level of the fluid in the at least one collection lumen based on a plurality of demarcations on the delivery tube (step 1515).

Turning now to Figure 16, a process that may be implemented by a reduced pressure treatment system such as reduced pressure treatment system 1000 in Figure 10 is shown in accordance with an illustrative embodiment. The process applies a reduced pressure to the tissue site using a reduced pressure source (step 1605). The process determines whether there is a presence of a threshold amount of reduced pressure in a delivery tube or other component of a reduced pressure treatment system (step 1610). If the process determines that there is not a presence of a threshold amount of reduced pressure, the process moves an indicator into an

extended position using a compressible member. The process then returns to step 1605. Returning to step 1610, if the process determines that there is a presence of a threshold amount of reduced pressure, the process moves the indicator into the retracted position (step 1620).

The flowcharts and block diagrams in the different depicted embodiments illustrate the architecture, functionality, and operation of some possible implementations of the apparatus and methods. In some alternative implementations, the function or functions noted in the block may occur out of the order noted in the figures. For example, in some cases, two blocks shown in succession may be executed substantially concurrently, or the blocks may sometimes be executed in the reverse order, depending upon the functionality involved.

CLAIMS

We claim:

1. An apparatus for administering reduced pressure to a tissue site, the apparatus comprising:
a reduced pressure source, the reduced pressure source generating a reduced pressure; and
a tube having a plurality of lumens, the plurality of lumens including at least one collection lumen, the reduced pressure source capable of applying the reduced pressure to the tissue site through the plurality of lumens such that the at least one collection lumen receives fluid from the tissue site, the at least one collection lumen storing the fluid received from the tissue site;
wherein the at least one collection lumen includes an absorptive material.
2. The apparatus of claim 1, further comprising at least one filter coupled to the tube, wherein the at least one filter is located at one or more locations, and wherein the at least one filter prevents the fluid from passing the one or more locations.
3. The apparatus of claim 2, wherein the at least one filter includes at least one of a hydrophobic filter, a hydrophilic filter, and a mechanical valve.
4. The apparatus of claim 2, further comprising:
a delivery lumen, wherein the plurality of lumens includes the delivery lumen; and
a delivery lumen filter in the at least one filter, wherein the delivery lumen filter is coupled to the delivery lumen, and wherein the delivery lumen filter prevents the fluid from entering the delivery lumen.
5. The apparatus of claim 4, wherein the delivery lumen has a larger cross-section than the at least one collection lumen.
6. The apparatus of claim 5, wherein the at least one collection lumen is a plurality of collection lumens, and wherein each of the plurality of collection lumens is equidistant from the delivery lumen, and wherein the delivery lumen is located along the longitudinal center of the tube.

7. The apparatus of claim 4, wherein the delivery lumen filter is coupled to an end of the tube adjacent to the tissue site, further comprising a manifold coupled to the end of the tube adjacent to the tissue site, wherein the at least one collection lumen receives fluid from the tissue site via the manifold.
8. The apparatus of claim 2, wherein the at least one filter further comprises at least one collection lumen filter coupled to the at least one collection lumen, the at least one collection lumen filter preventing the fluid from passing one or more locations at the at least one collection lumen.
9. The apparatus of claim 8, wherein the at least one collection lumen filter is coupled to an end of the tube adjacent to the reduced pressure source, and wherein the at least one collection lumen filter prevents the fluid from exiting the at least one collection lumen.
10. The apparatus of claim 1, wherein the tube is substantially transparent such that the fluid received by the at least one collection lumen is visible.
11. The apparatus of claim 10, wherein the tube includes a plurality of demarcations that indicate an amount of fluid in the at least one collection lumen.
12. Use, for administering reduced pressure to a tissue site, of:
 - a reduced pressure source capable of applying reduced pressure to the tissue site, the reduced pressure source capable of applying reduced pressure to the tissue site via a plurality of lumens in a delivery tube;
 - fluid from the tissue site storable in at least one collection lumen in the plurality of lumens, the at least one collection lumen including an absorptive material; and
 - a fluid level of the fluid in the at least one collection lumen determinable based on a plurality of demarcations located on the delivery tube.

1/10

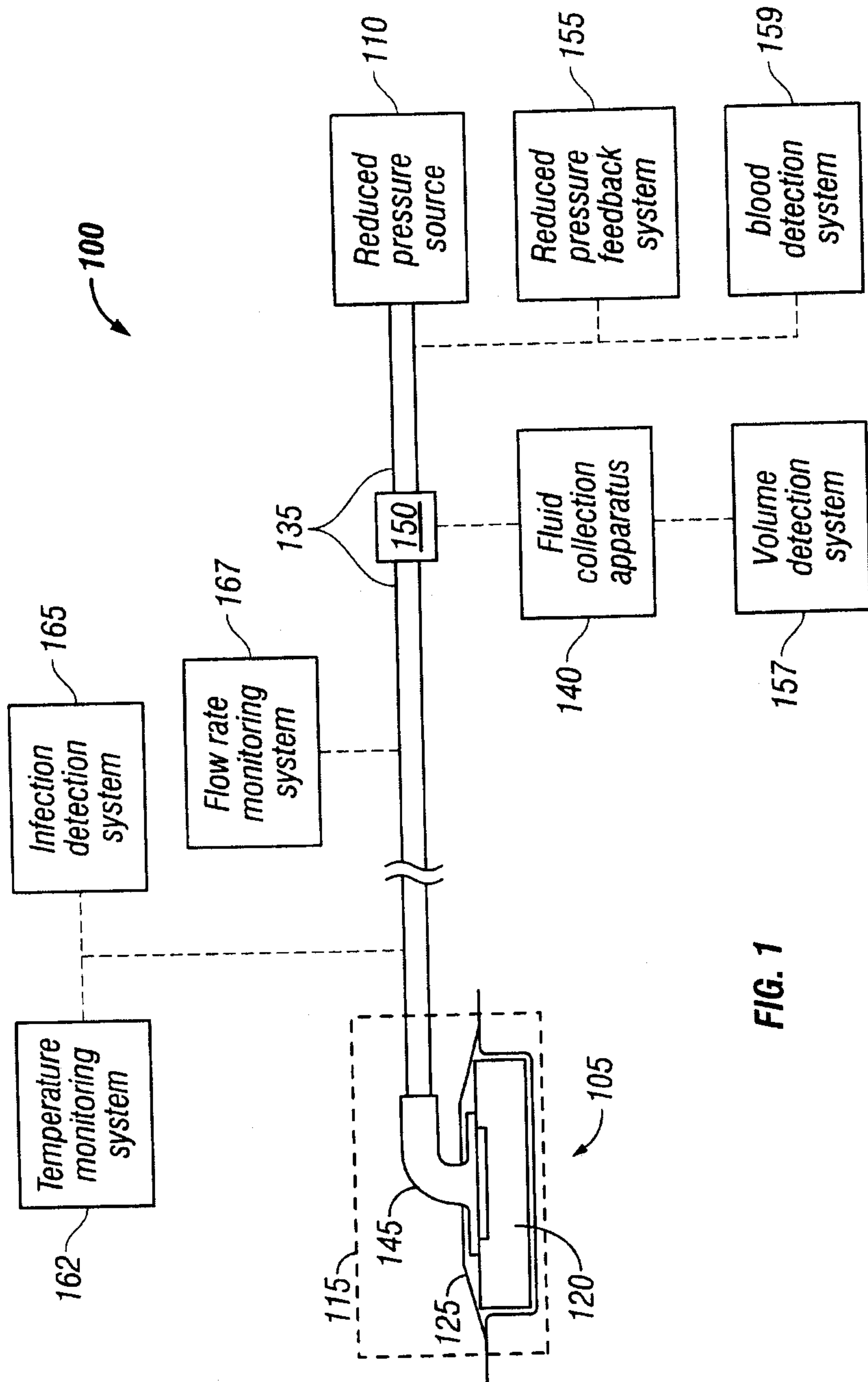

FIG. 1

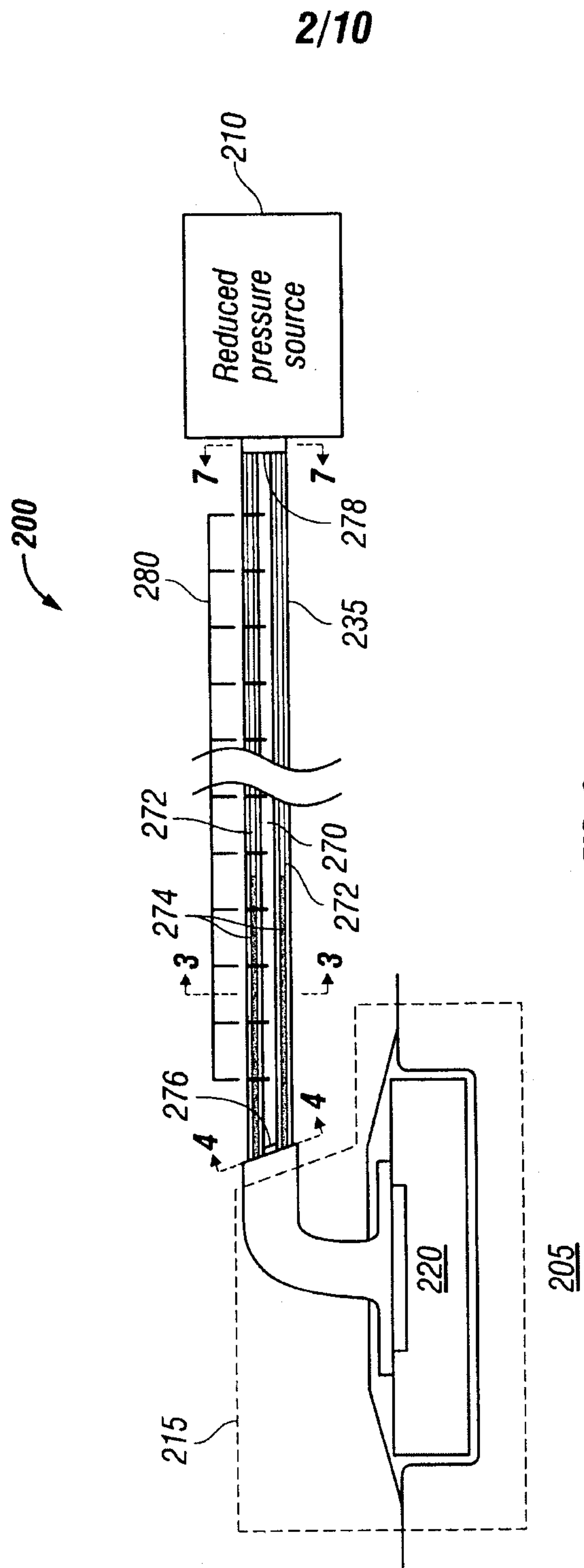
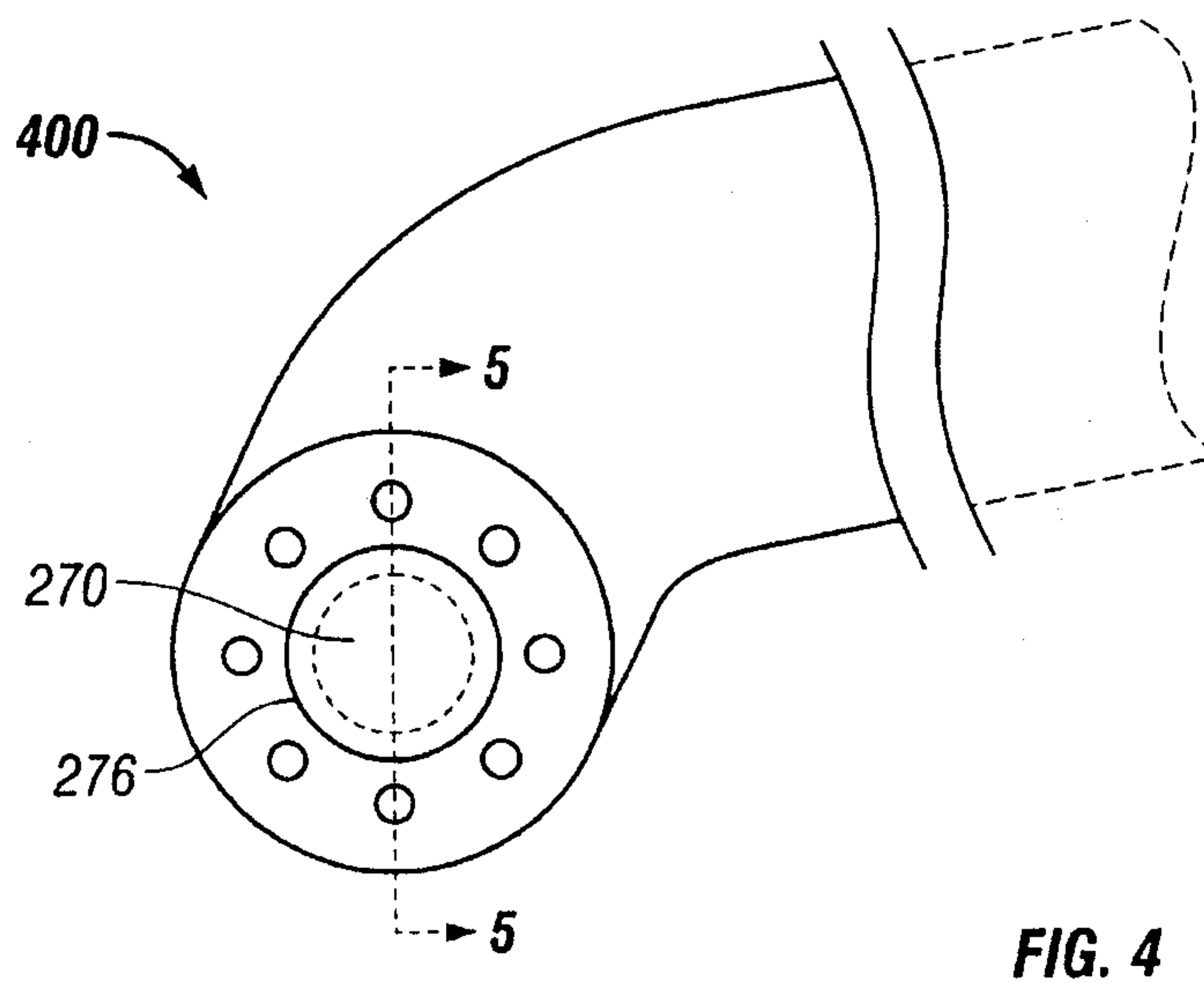
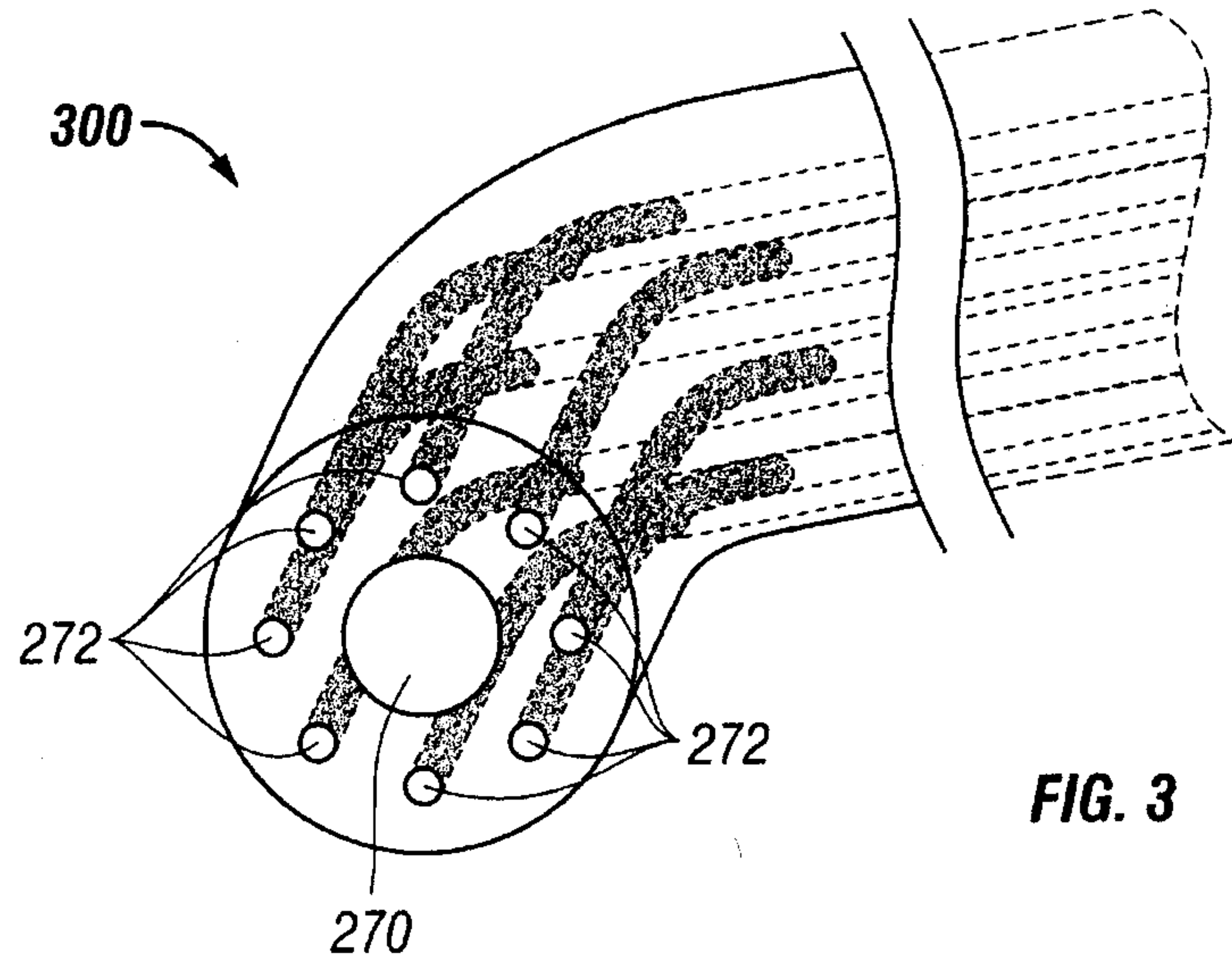

FIG. 2

3/10



4/10

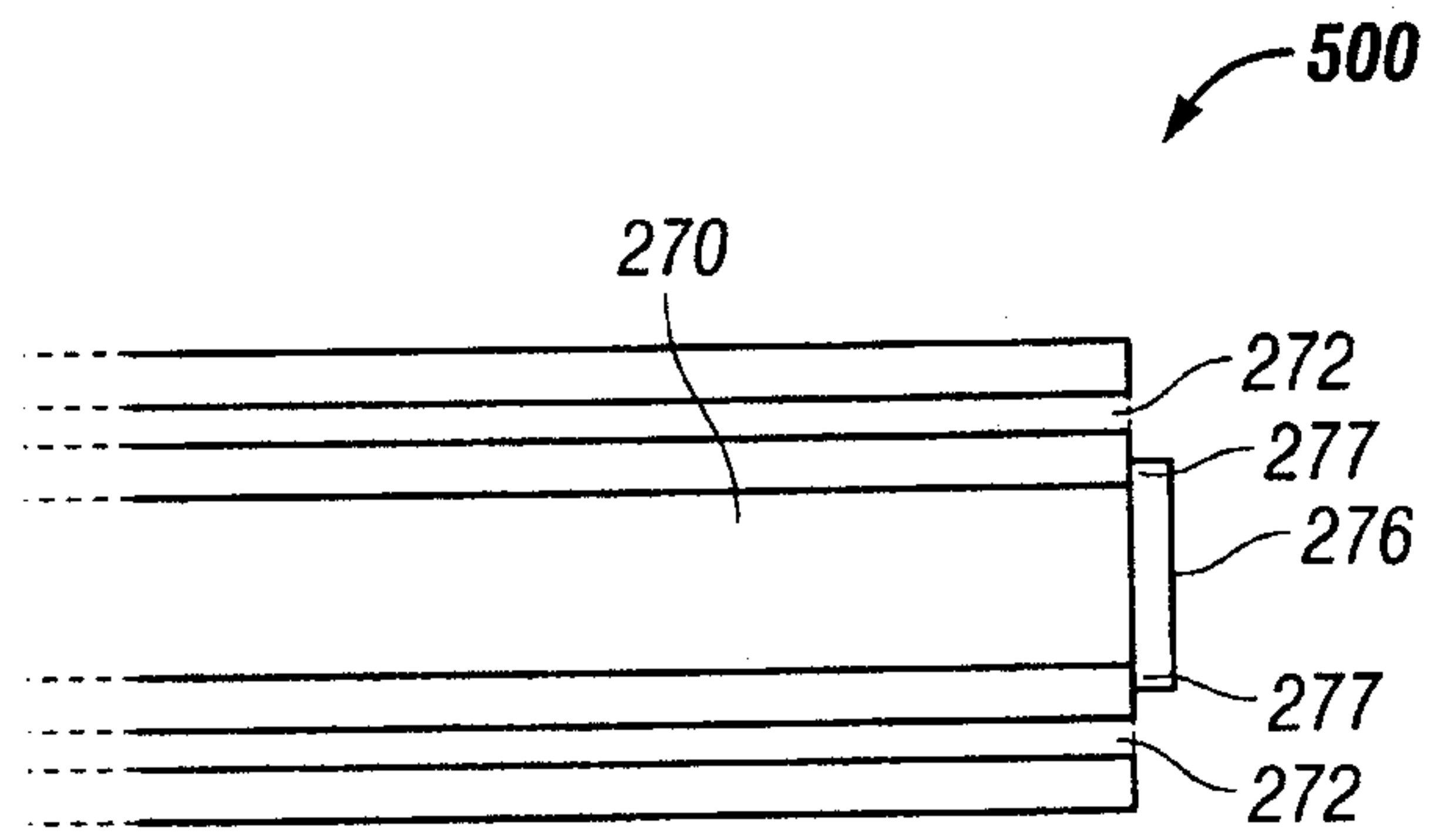

FIG. 5

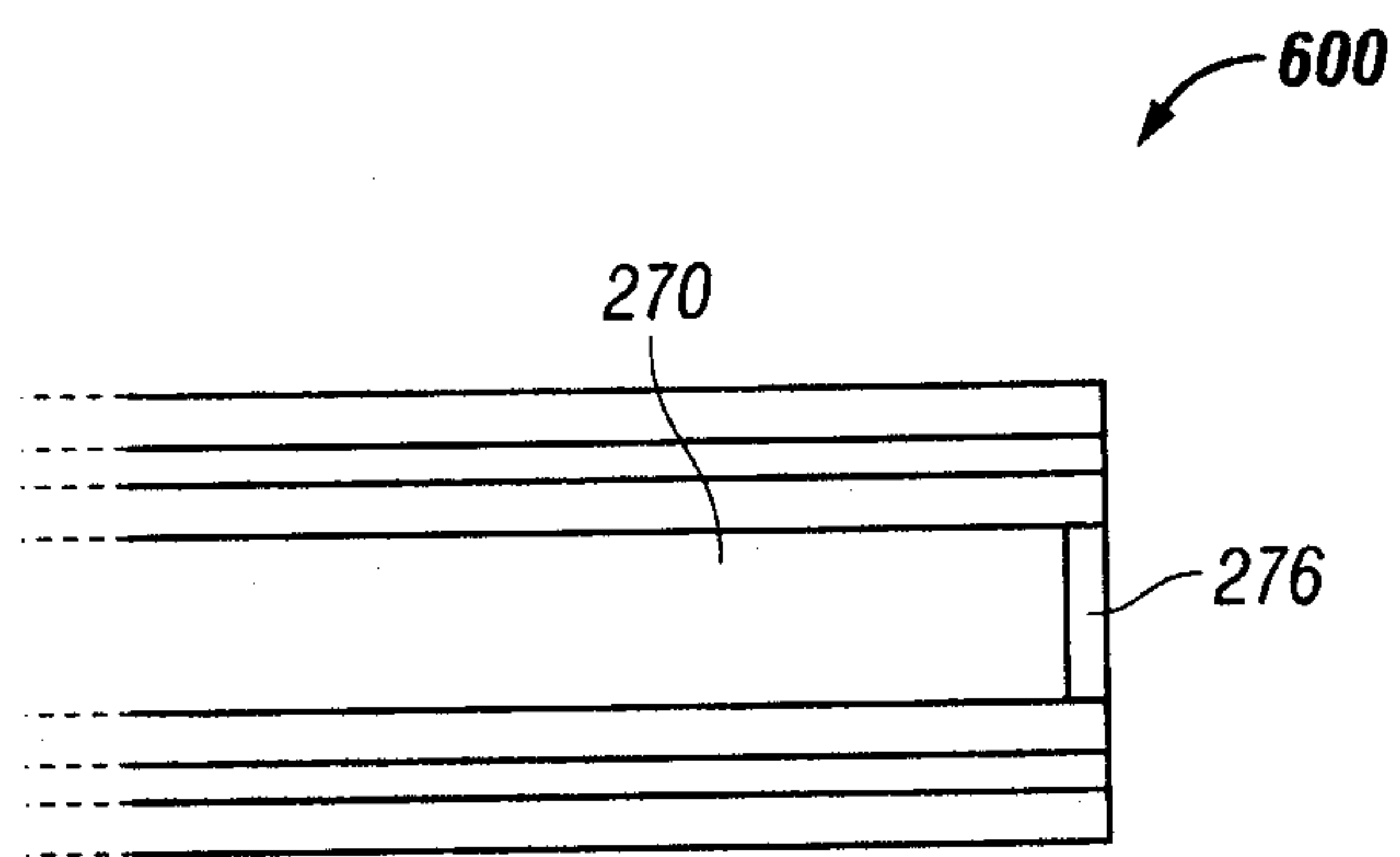

FIG. 6

5/10

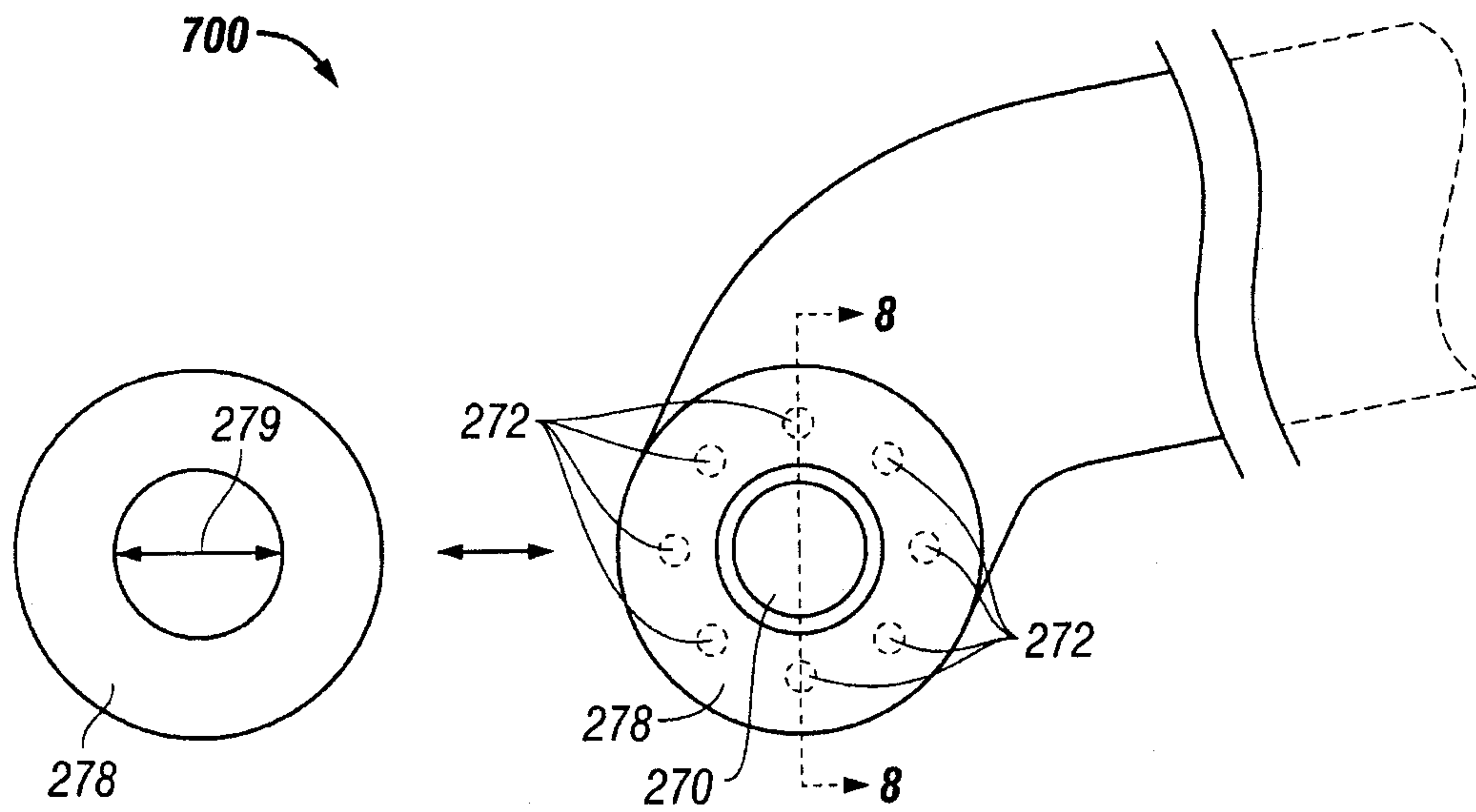

FIG. 7

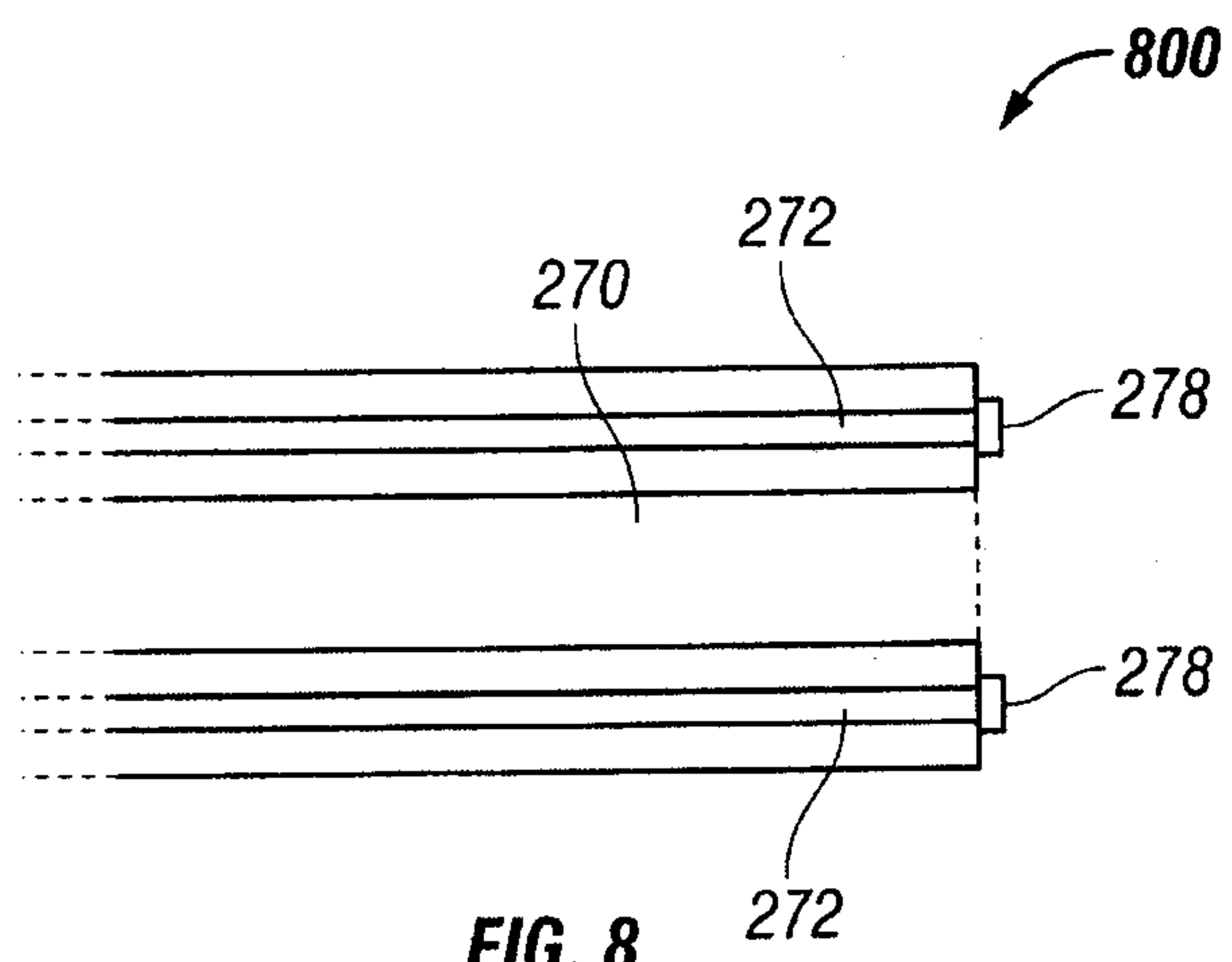

FIG. 8

6/10

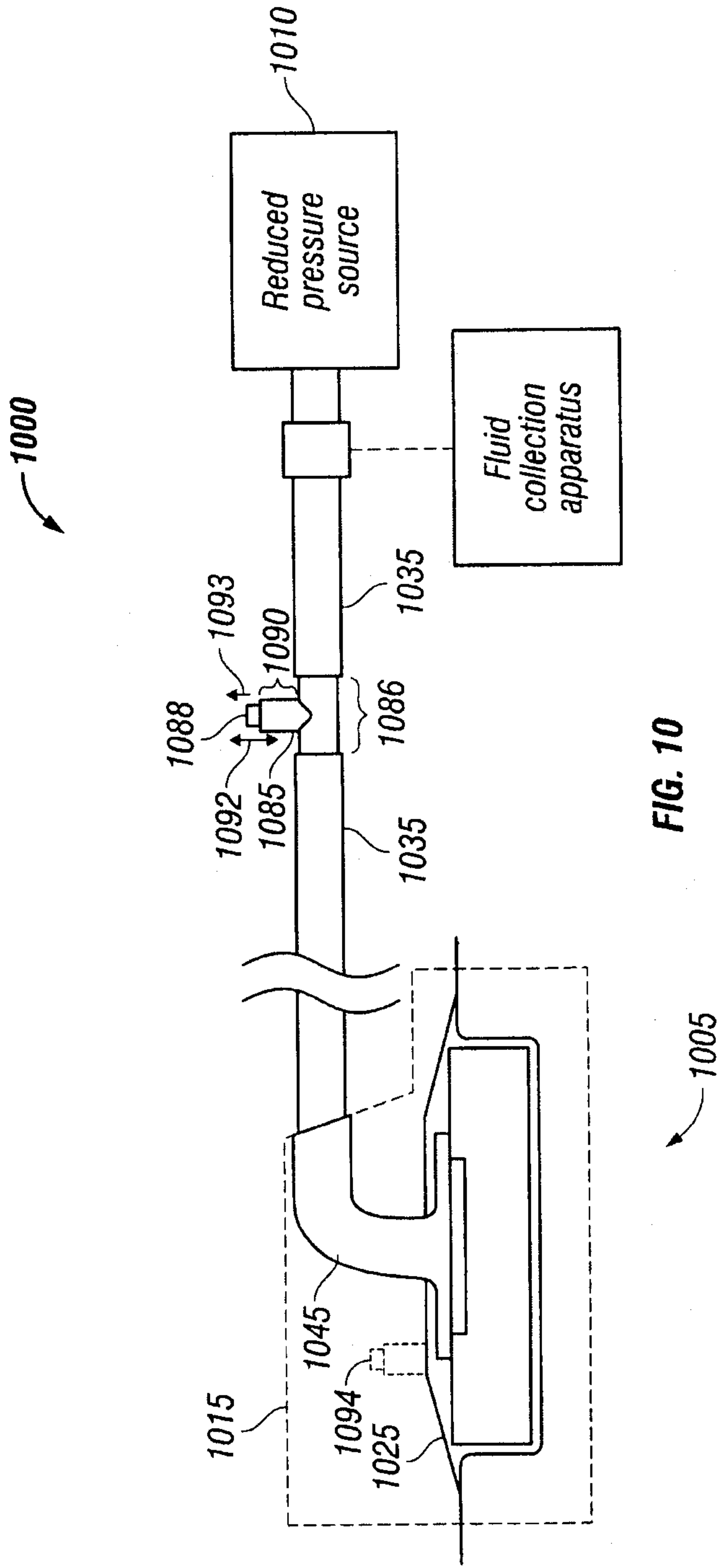
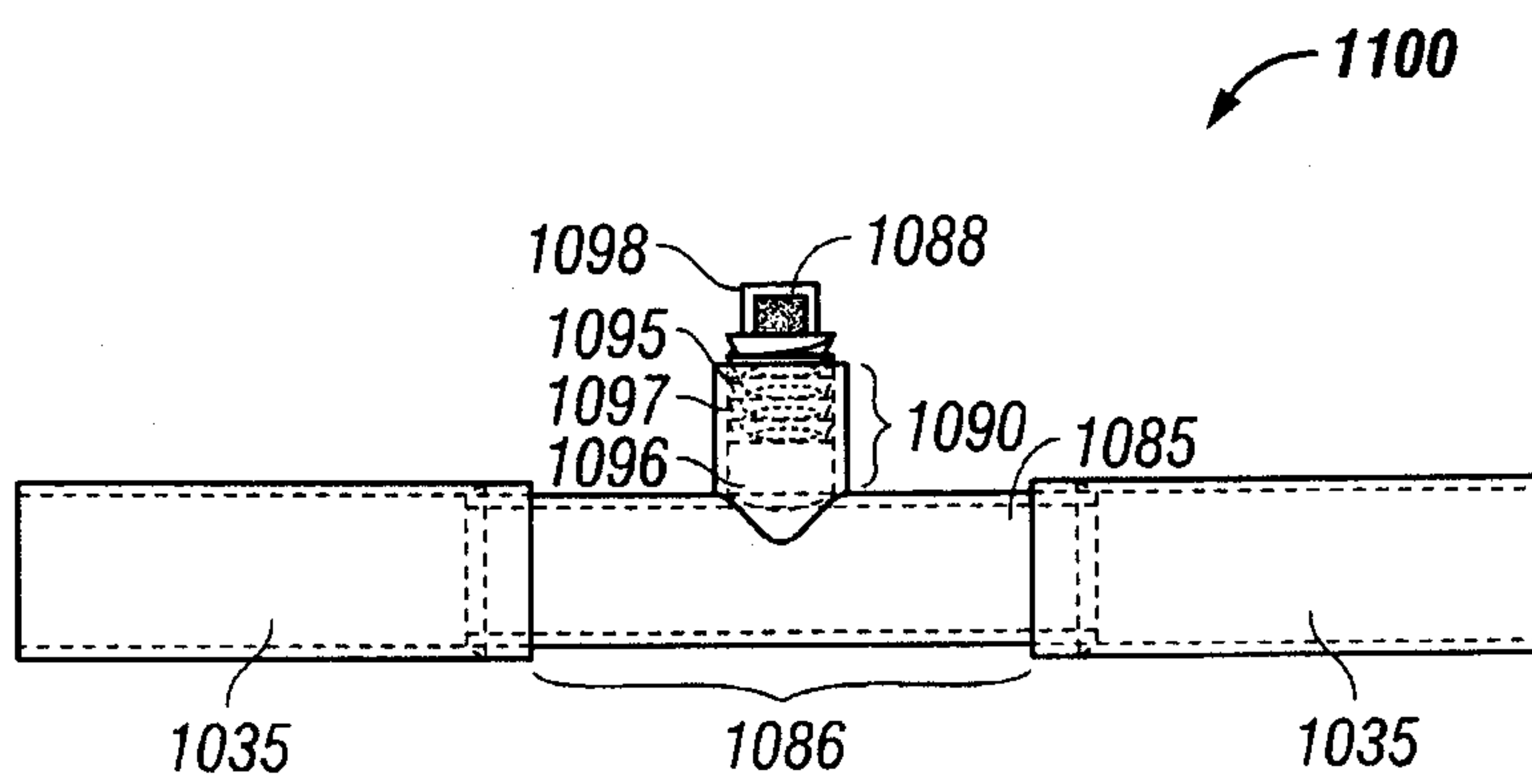
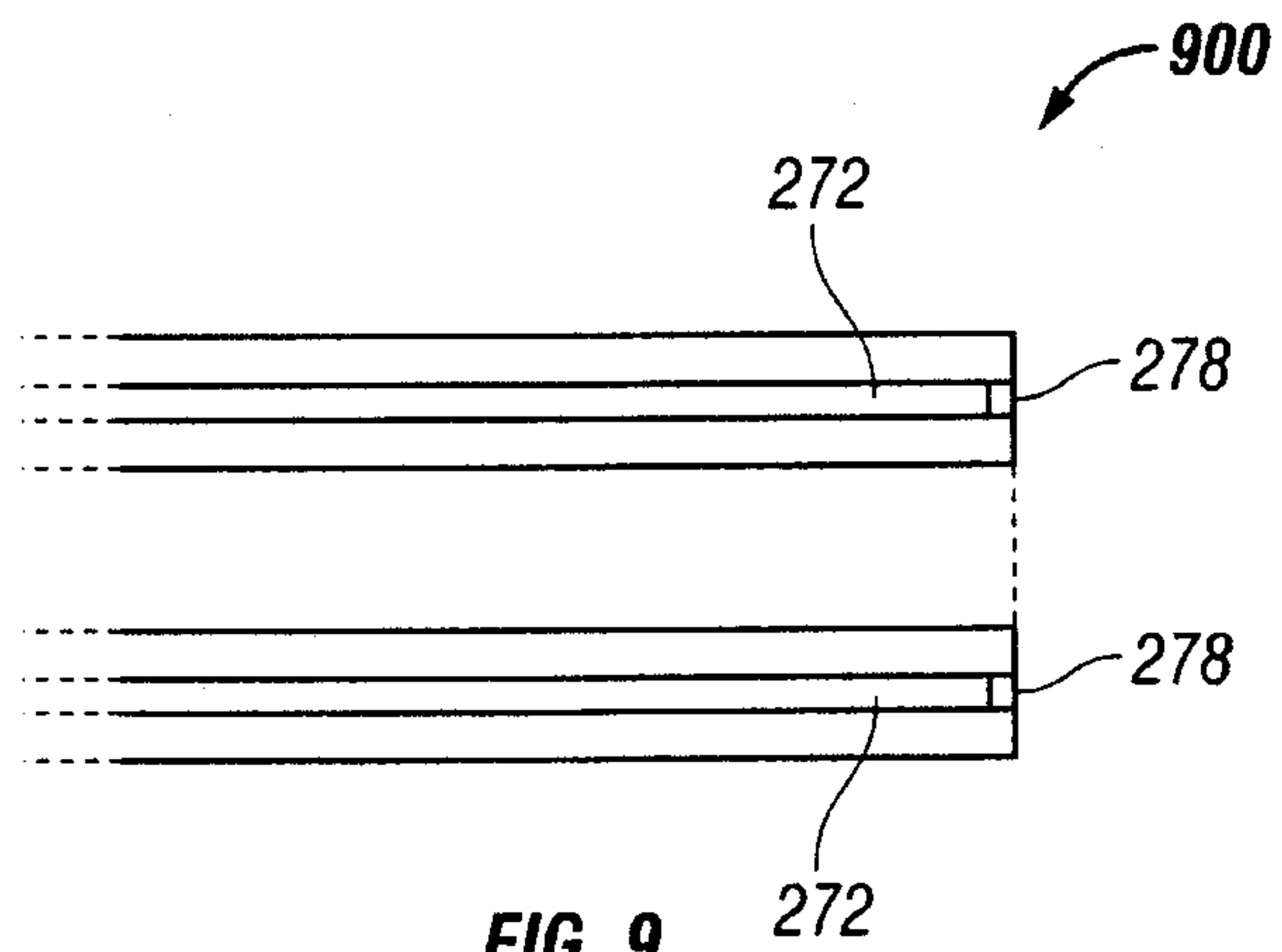

FIG. 10

7/10



8/10

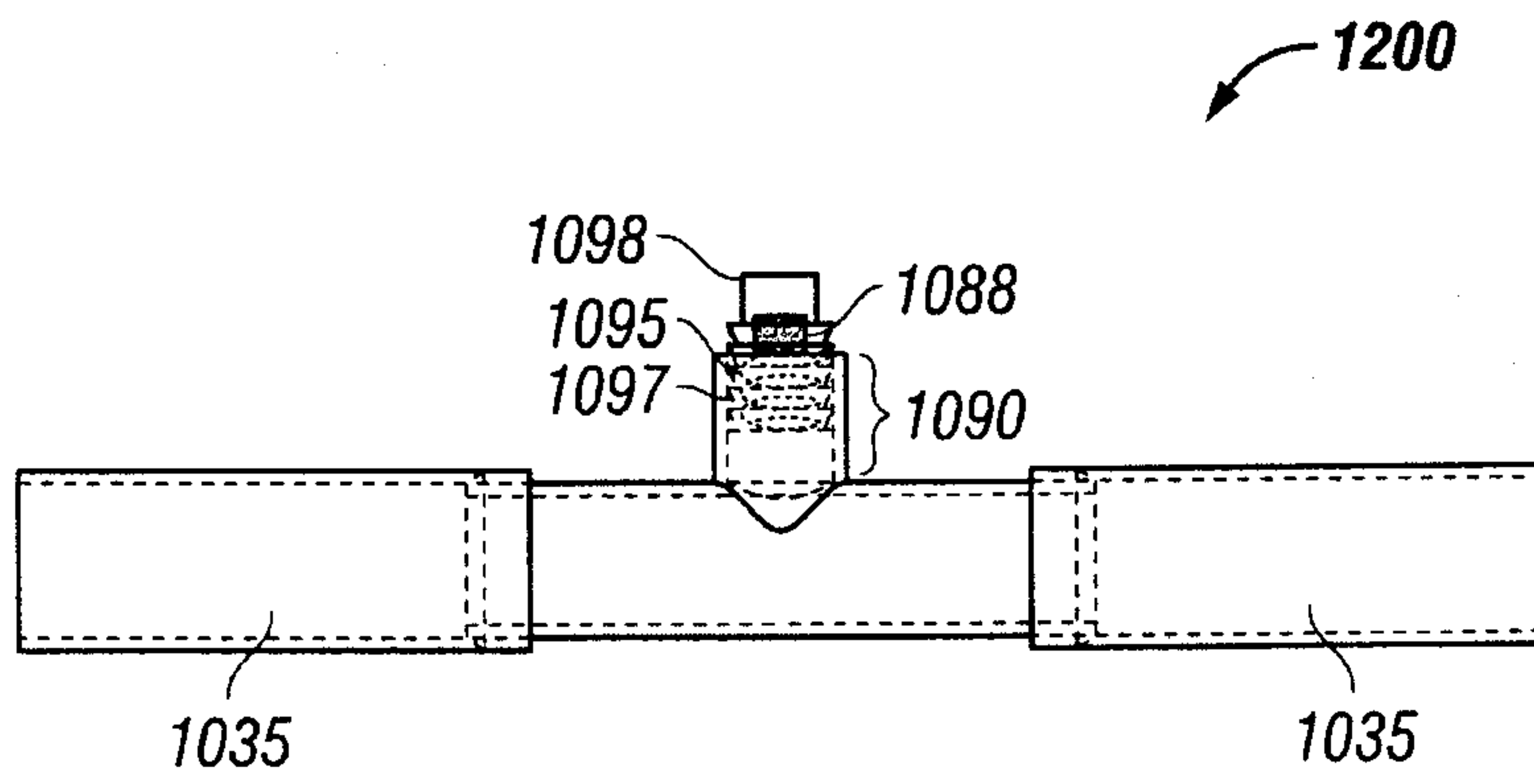
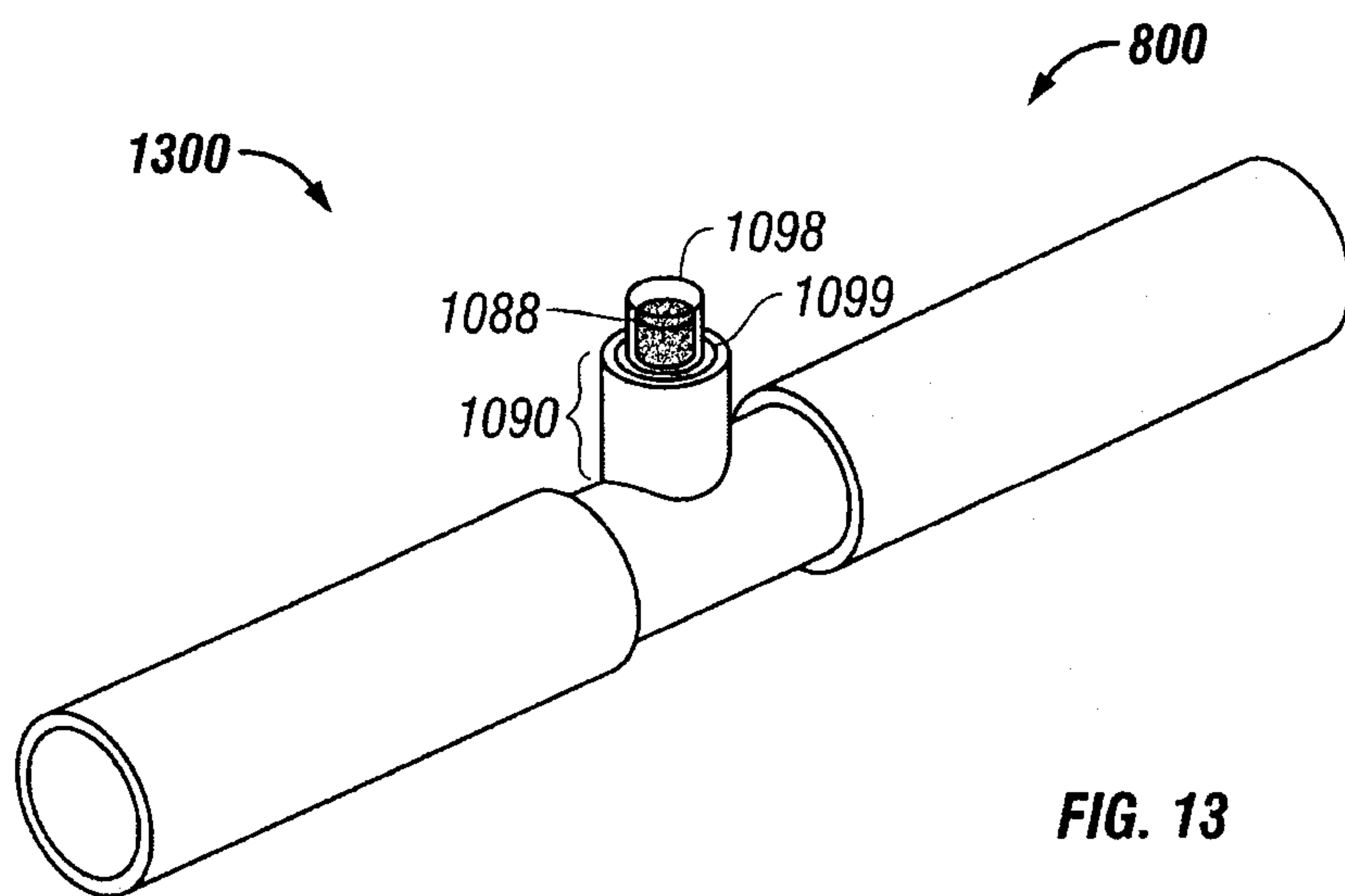

FIG. 12



9/10

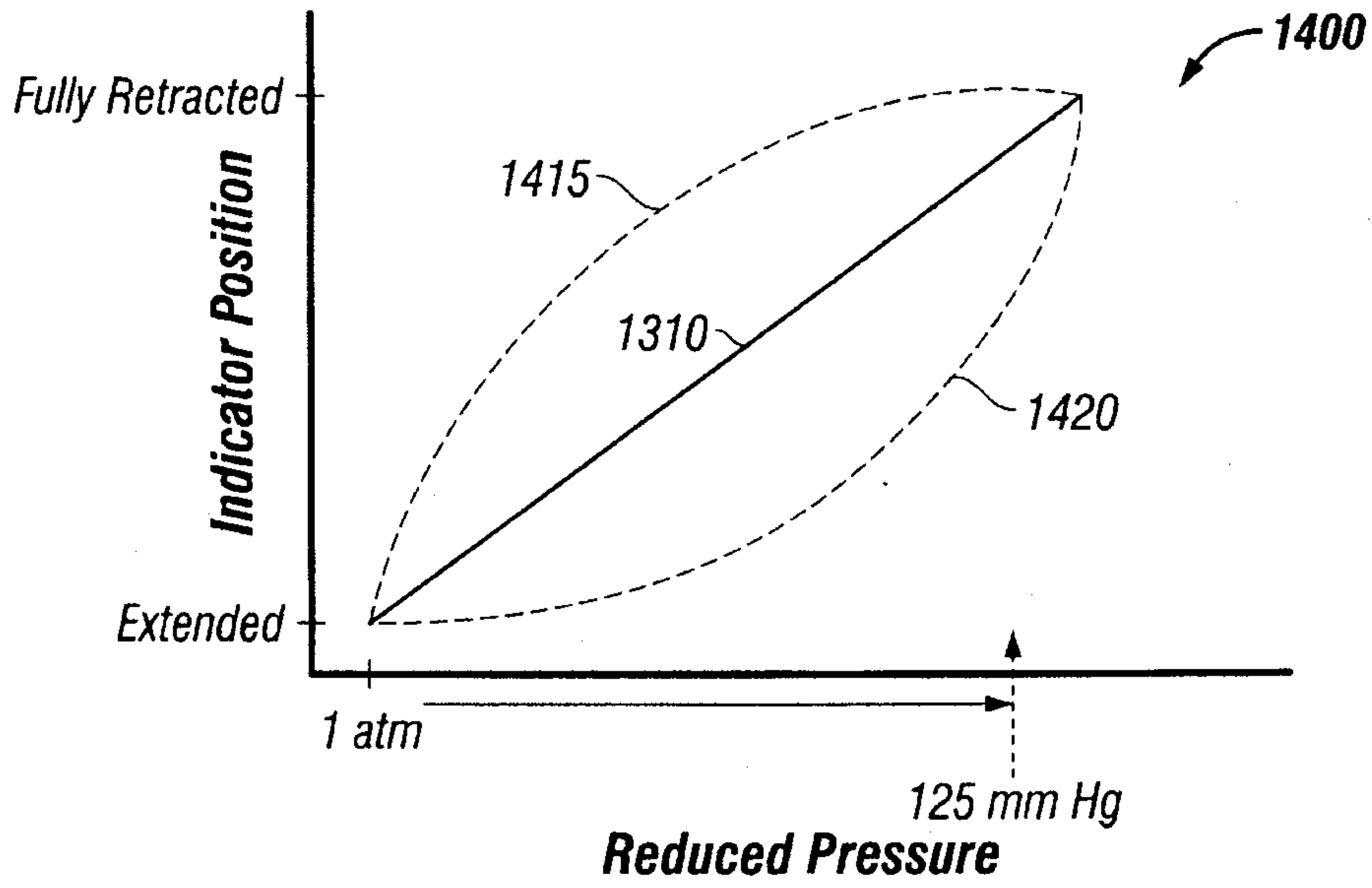

FIG. 14

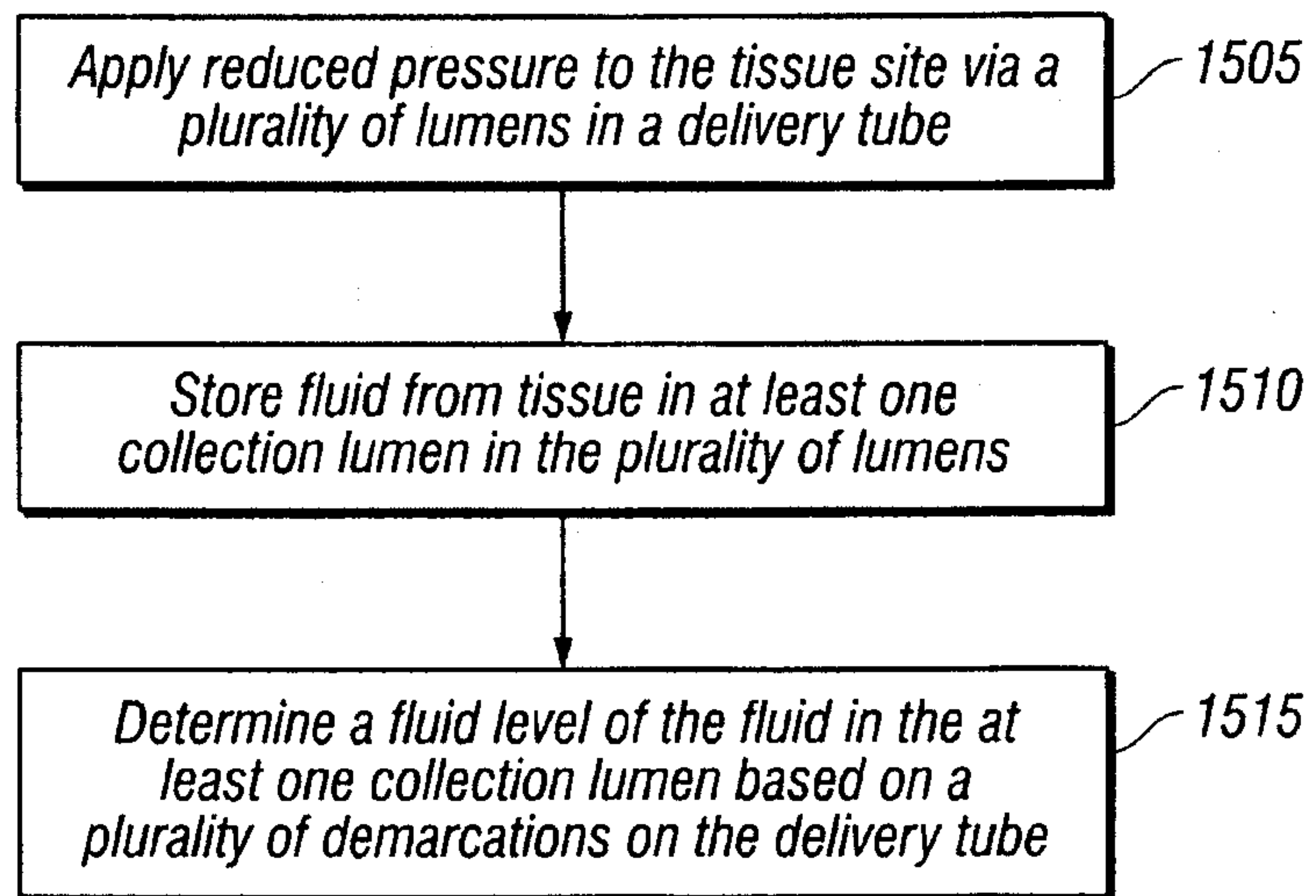

FIG. 15

10/10

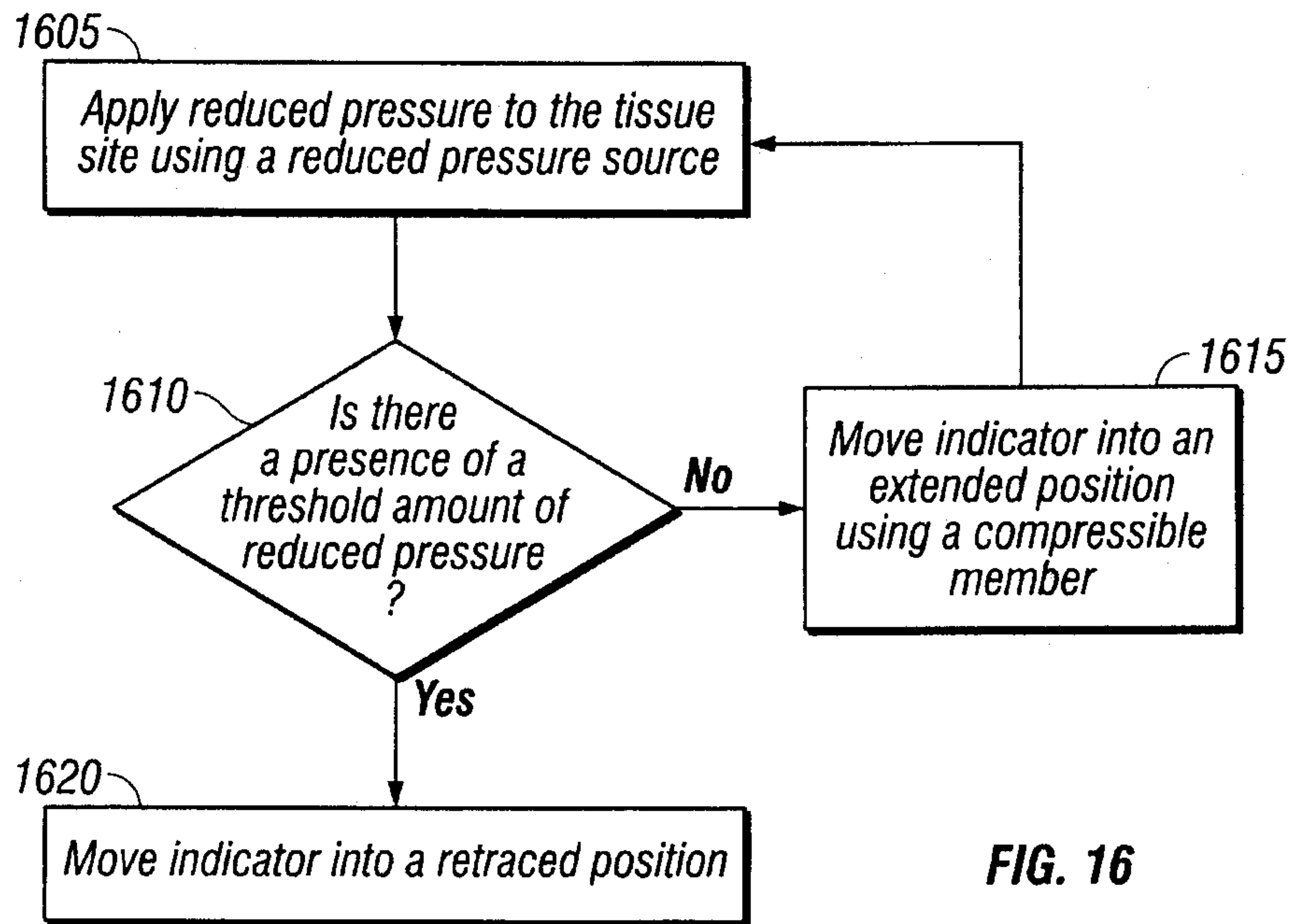

FIG. 16

