

C. FLAGGE.

AUTOMATIC SUGAR PURGING APPARATUS.

No. 192,004.

Patented June 12, 1877.

Fig. 1

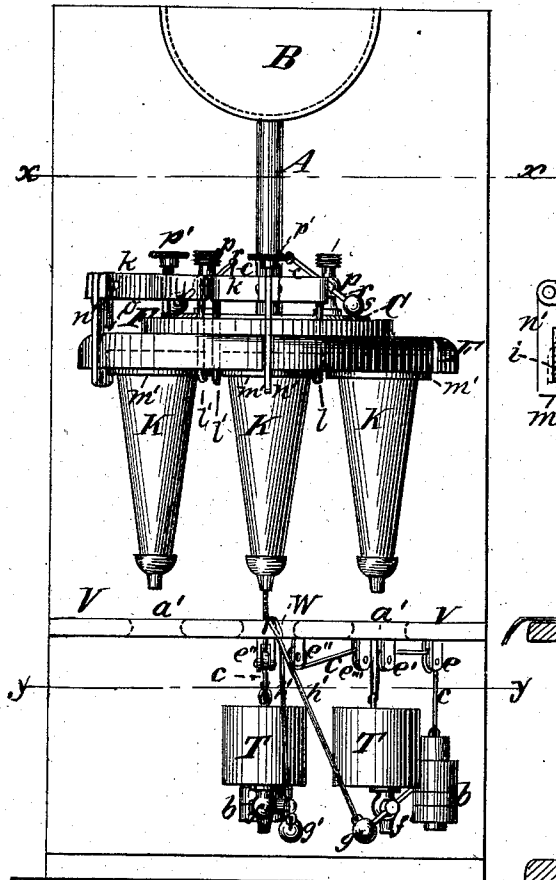

Fig. 2.

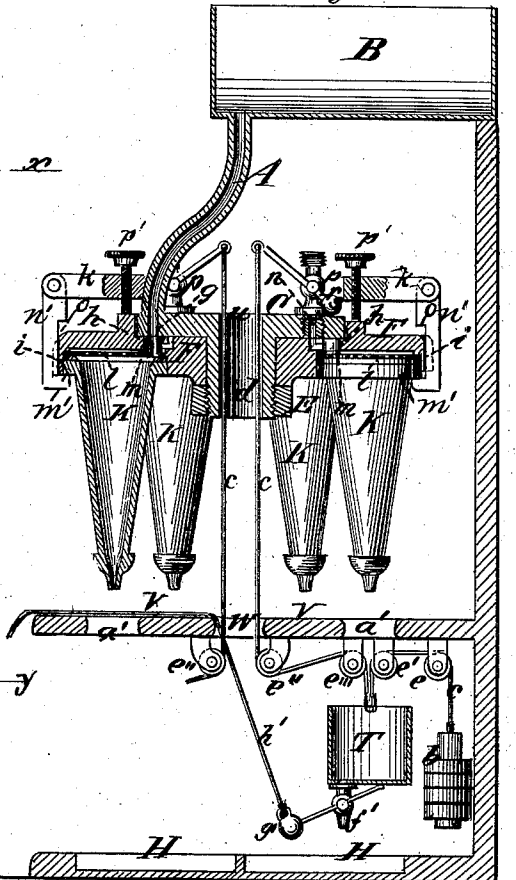

Fig. 3.

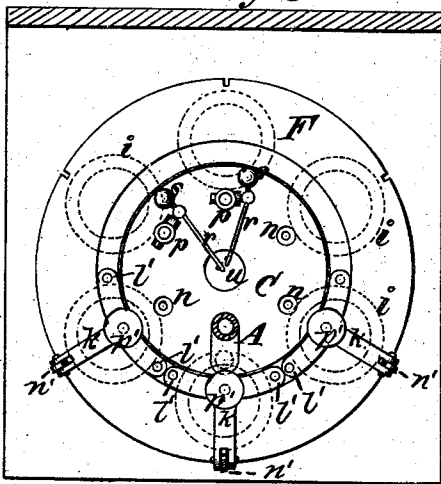
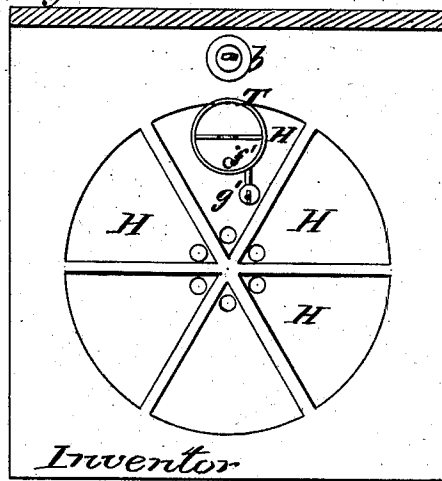

Fig. 4.



Witnesses:
John Decker
Fred. Wagner

Inventor
Charles Flagge
by his Attorneys
Brown & Allen.

UNITED STATES PATENT OFFICE

CHARLES PLAGGE, OF NEW YORK, N. Y.

IMPROVEMENT IN AUTOMATIC SUGAR-PURGING APPARATUS.

Specification forming part of Letters Patent No. 192,004, dated June 12, 1877; application filed November 14, 1876.

To all whom it may concern:

Be it known that I, CHARLES PLAGGE, of the city, county, and State of New York, have invented an Automatic Purging Apparatus for Purging Sugar; and I do hereby declare that the following is a full, clear, and exact description of the same, reference being had to the accompanying drawing, which forms part of this specification.

In the process of purging sugar, as heretofore principally conducted, the dark-colored sirup which adheres to the crystals of sugar when it is drawn from the vacuum-pans, in the state technically known as "green sugar," is purged from the said crystals by successively pouring upon the green sugar, when run into molds, sirups of various grades of whiteness, proceeding from dark to light colored sirups, and ending with a pure white sirup, such sirups filtering through the sugar in the molds, and each lighter-colored sirup displacing a darker-colored one, till the crystals are purged or washed and freed from discoloration. The sugar is then drained, which completes the operation.

In this tedious method the sirups required for the purging are inaccurately apportioned to the sugar to be purged, the sirups being frequently used in larger quantity than is necessary to perform the purging were the sirups economically applied; and the process is unnecessarily prolonged on account of the time required for the filtration of the excess of sirups used.

It is the object of my invention to facilitate the process of purging, to render its execution much more convenient, and provide for the accurate and automatic apportionment of the purging sirups or liquors; and my invention consists in an apparatus for securing these desirable results.

Figure 1 in the accompanying drawing represents a front view of the apparatus. Fig. 2 is a vertical central section through the same. Fig. 3 is a horizontal section on the line *xx* in Fig. 1, and Fig. 4 is a horizontal section on the line *yy* in Fig. 2.

A, Figs. 1, 2, and 3, is a pipe, through which the green sugar is conveyed to the molds attached to the purging apparatus directly from the receiver B, or the molds may be filled

and afterward attached to the purging apparatus. The lower end of said pipe A is attached to a fixed circular plate, C. From the center of the plate C extends downward a cylindrical projection, *d*, Fig. 2, threaded on its lower part to receive the nut E.

Fitted accurately to the said cylindrical projection *d*, for a bearing, is a mold-carrying cut-off plate, F, Figs. 1, 2, and 3. The upper part of the plate F is also accurately fitted to the under side of the plate C, and holds snugly against the said plate C by the nut E, but not so snugly as to prevent its turning freely on its projecting bearing *d*.

The interior of the pipe A and a passage, *g*, Fig. 2, formed in the plate C, constitute a fixed continuous passage.

Through the mold-carrying cut-off plate F are formed, at equal distances from the center of said plate, and at equal distances from each other, passages *h*, Fig. 2, which may be successively brought under the passage *g* in the plate C by turning the said plate F on its central bearing *d*. Each of the passages *h* terminates on the under side of the plate F in one of a series of recesses, *i*, Fig. 2, arranged at equal distances from each other, and from the center of said plate, the arrangement of said recesses being shown in outline in Fig. 3. Into the said recesses *i* are fitted the tops of the sugar-molds K, Figs. 1 and 2. Said molds K are held up into the said recesses by a suitable clamping or attaching device, which permits their ready removal and easy attachment.

The clamping device preferred is shown in Figs. 1, 2, and 3. It consists in a T-shaped body, *k*, having rods *l* at the ends of two of its arms, which rods pass through the plate F, and turn under a flange, *m*', formed on the top of the mold K. At the end of the other arm, which extends radially outward, is a link, *n*', having a notch, *o*, which allows it to close down and engage the under side of said flange *m*'. Through the body *k* is passed a set screw, *p*', which, when the parts are adjusted, as described, tightly clamps the molds to the said plate.

At the top of each sugar-mold is placed a strainer, *l*, of wire-gauze, or a reticulated plate, the perforations in which are of suffi-

cient fineness to prevent the passage of crystallized sugar, but which permit the passage of sirups. From the top of each strainer *l* rises a short tube, *m*, Fig. 2, which meets one of the passages *h* in the plate F, the interior of said tube *m* forming a continuation of the said passage *h* through the said plate F, into the corresponding mold attached to said plate below said passage.

In the plate C are formed passages *n*, Figs. 2 and 3, said passages being so placed as to be on radial lines between the centers of the recesses *i*, and the center of the plate C, whenever any one of the passages *h* in the plate F is brought under the passage *g* in the plate C.

When the plates are placed, as described, in relation to each other each of the passages *n* communicates with a corresponding recess, *i*, in the plate F above the strainer *l* in said recess.

The said passages are made to communicate with receptacles for the purging-sirups by suitable pipes, provided with cocks *p*, Figs. 1, 2, and 3, said cocks being operated as hereinafter described. The plugs of the cocks *p* are turned by weighted levers *r*, the weights *s* being attached to the short arms of said levers to open said cocks, and the long arm of said levers being connected with apportioning-buckets T by cords or other flexible connectors passing through a hole, *u*, Figs. 2 and 3, in the center of the plate C, and a hole, W, in the floor or platform V, upon which the operator stands in working the apparatus, and over pulleys *e'' e'''*, to close said cocks as hereinafter described. In the said floor or platform V are pierced holes *a'*, Figs. 1 and 2, arranged to lie under the molds K when any one of the passages *h* in the plate F is brought under the passage *g* in the plate C; and under each of said holes *a'*, except the one under the said passage *g* in the plate C, is placed one of the apportioning-buckets T.

Each of said apportioning-buckets is counterpoised by a weight, *b*, attached to said buckets by a cord, *c*, Figs. 1, 2, and 3, running over pulleys *e e'*, for which cord and pulleys a lever may be substituted, if desired.

Each apportioning-bucket, T, is provided with a discharge-cock, *f'*, Figs. 1 and 2, the plug of which is turned by a weighted lever, the weight *g'* being placed on the long arm of said lever, and a lifting-cord, *h'*, attached to said lever passes up through a central hole, W, in the floor or platform, within easy reach of the operator.

The cords attached to the weights *g'* of the several discharge-cocks *f'* are united into or to a single cord above the platform W in such manner that, by drawing up such cord, the said discharge-cocks may be simultaneously opened, the weights *g'* closing said cocks when the said cord is slackened.

Below each apportioning-bucket is placed a collecting-receptacle, H, to collect the discharged sirups and keep separate the different grades of sirups used in the several molds,

as hereinafter described, said sirups being drawn from said receptacles for further use.

The apparatus may be constructed to employ any convenient number of molds, but at least two must be used. The operation of the apparatus is as follows:

The operator turns the plate F till one of the passages *h* in said plate is brought fully under the passage *g* in the plate C, which can be accurately done by guide-marks on the plate F and plate C by automatic stopping devices or any other convenient method. The green sugar then runs in and fills the mold thus brought under the passage *g* in the plate C, but is prevented from rising to the top of the recess *i* over said mold by the strainer *l* at the top of the mold hereinbefore described.

When the first mold is thus filled the operator turns the plate F to bring another mold under the passage *g*. This brings the recess *i* at the top of the filled mold, under one of the series of passages *n* formed in the plate C, through which the first grade of the purging-sirups employed passes into the space in the recess above the strainer *l*. Said strainer distributes the sirup, and causes it to filter uniformly through all parts of the sugar contained in the mold below. By experiment, the amount of sirup necessary to filter through, as described, is ascertained, and the apportioning-buckets T below the molds are counterpoised, so that they will fall whenever this amount is reached. In falling they pull upon the flexible connectors *c*, which act upon the cocks *p* to cut off the flow of purging-sirups. The sugar in the first-filled mold is thus partially purged, while the second mold in order is filling with green sugar, and when the proper amount of purging-sirup is passed through the said first-filled mold, which is indicated by the automatic turning of the cock *p* in the pipe which conveys the purging-sirup to said mold, the operator lifts the cord *h'* connected with the cocks *f'* in the bottoms of the apportioning-buckets, which allows the contents of said buckets to discharge. Then he slackens the said cord *h'*, which allows the cocks *f'* to be closed by the weighted levers. The counterpoises *b* then lift the apportioning-buckets, draw upon the cords *c*, and open the cocks *p* to allow the purging-sirups to pass again when the passages *n*, which are stopped by the cut-off plate F in turning the same, are again brought into communication with the recesses *i* in the proper position of the plate F for filling the next successive mold. This process is repeated until all the molds are filled, lighter-colored grades of purging-sirups being successively passed through said molds to complete the purging. Then the operator takes off from the plate F the first-filled mold and puts on an empty one, and thereafter the process becomes continuous, all the filled molds undergoing the purging process while the unfilled mold is filling.

The sirups used for purging may be made to pass through the molds under pressure, or

other agents, such as steam or air, may be blown through the molds in the latter part of the purging of the sugar contained in said molds; or the lower part of the molds may be connected with an exhausting apparatus to force out the remaining liquid by atmospheric pressure. To indicate the complete passage of the purging-sirups whistles or bells may be used, said whistles or bells being sounded when the cocks *p* are turned to cut off the flow of said sirups.

I claim—

1. The combination of the fixed plate C, having the passages *n* and *g*, the mold - carrying cut-off plate F, having the passages *h* formed therein, and the molds K, substantially as and for the purpose described.

2. The combination, with the fixed plate C, the plate F, and molds K, all constructed substantially as described, of an automatic counterpoised apportioning apparatus, arranged to receive the purging-sirups after passing through the molds, and control their flow, substantially as and for the purpose set forth.

3. The combination of the receiver B and pipe A with the fixed plate C, mold-carrying cut-off plate F, and molds K, all constructed

and arranged substantially as and for the purpose set forth.

4. The combination of the mold - carrying cut-off plate, the molds K, and a clamping device for attaching said molds to said plate, substantially as and for the purpose specified.

5. The combination of the pipe A, the plate C, having passage *g*, and the plate F, having passages *h*, the strainers *l*, and the short tubes *m* attached to the latter, and arranged to form a continuous passage from the receiver B when the said parts are brought into relation with each other, substantially as and for the purpose described.

6. The combination, with the revolving plate F and the molds K, of the strainers *l*, constructed and arranged to allow green sugar to flow into the mold for filling said mold, and purging-sirups to subsequently pass into said molds for purging the contained sugar, substantially as and for the purpose specified.

CHARLES PLAGGE.

Witnesses:

MICHAEL RYAN,
FRED. HAYNES.