

(12) INTERNATIONAL APPLICATION PUBLISHED UNDER THE PATENT COOPERATION TREATY (PCT)

(19) World Intellectual Property Organization
International Bureau



(43) International Publication Date
31 October 2002 (31.10.2002)

PCT

(10) International Publication Number
WO 02/086286 A2

(51) International Patent Classification⁷: E21B 43/10

Michael [GB/GB]; Blackchambers, Westhill, Aberdeenshire AB32 7BU (GB).

(21) International Application Number: PCT/GB02/01879

(74) Agent: MURGITROYD & COMPANY; 165-169 Scotland Street, Glasgow G5 8PL (GB).

(22) International Filing Date: 24 April 2002 (24.04.2002)

(25) Filing Language: English

(81) Designated States (*national*): AE, AG, AL, AM, AT, AU, AZ, BA, BB, BG, BR, BY, BZ, CA, CH, CN, CO, CR, CU, CZ, DE, DK, DM, DZ, EE, ES, FI, GB, GD, GE, GH, GM, HR, HU, ID, IL, IN, IS, JP, KE, KG, KP, KR, KZ, LC, LK, LR, LS, LT, LU, LV, MA, MD, MG, MK, MN, MW, MX, MZ, NO, NZ, PL, PT, RO, RU, SD, SE, SG, SI, SK, SL, TJ, TM, TR, TT, TZ, UA, UG, US, UZ, VN, YU, ZA, ZW.

(26) Publication Language: English

(30) Priority Data:
0109993.6 24 April 2001 (24.04.2001) GB

(71) Applicant (*for all designated States except US*): E2 TECH LIMITED [GB/NL]; c/o Shell International B.V., P.O. Box 384, NL-2501 CJ The Hague (NL).

(84) Designated States (*regional*): ARIPO patent (GH, GM, KE, LS, MW, MZ, SD, SL, SZ, TZ, UG, ZM, ZW), Eurasian patent (AM, AZ, BY, KG, KZ, MD, RU, TJ, TM), European patent (AT, BE, CH, CY, DE, DK, ES, FI, FR, GB, GR, IE, IT, LU, MC, NL, PT, SE, TR), OAPI patent

(72) Inventor; and

(75) Inventor/Applicant (*for US only*): BURGE, Philip,

[Continued on next page]

(54) Title: METHOD OF AND APPARATUS FOR CASING A BOREHOLE

(57) Abstract: Methods of and apparatus for drilling, casing and/or completing a borehole (50) wherein one or more portions (50a to 50e) of the borehole (50) are drilled into a formation (52) at a single diameter along the entire length or depth of the or each portion (50a to 50e) of the borehole (50). An expandable tubular member (54a to 54e) is then located within the or each portion (50a to 50e) of the borehole (50) and radially expanded in the or each portion (50a to 50e) to line and/or case it or them. Optionally, a corrosion resistant member (56) and/or a service string (62) can be located in the borehole (50). An advantage of certain embodiments is that a single diameter borehole (50) is formed along the entire length or depth thereof.

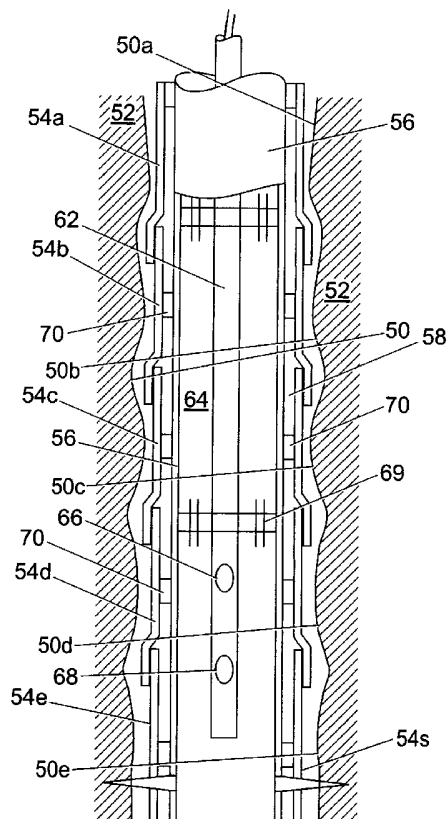

WO 02/086286 A2



(BF, BJ, CF, CG, CI, CM, GA, GN, GQ, GW, ML, MR, NE, SN, TD, TG).

For two-letter codes and other abbreviations, refer to the "Guidance Notes on Codes and Abbreviations" appearing at the beginning of each regular issue of the PCT Gazette.

Published:

— *without international search report and to be republished upon receipt of that report*

1 "Method of and Apparatus for Casing a Borehole"

2

3 The present invention relates to a method of
4 drilling, casing and/or completing a borehole, and
5 in particular to a method of drilling, casing and/or
6 cladding a borehole. The invention also provides
7 apparatus for completing a borehole. It will be
8 understood that use of the term "borehole" herein is
9 a reference to a bore that has been drilled into a
10 formation to allow the recovery of hydrocarbons (or
11 other fluids) therefrom as is conventional in the
12 art.

13

14 When a borehole has been drilled into a formation to
15 facilitate, for example, the recovery of
16 hydrocarbons from a well or reservoir, the formation
17 surrounding the borehole is typically lined with a
18 casing. Casing is installed to prevent the
19 formation around the borehole from collapsing, and
20 additionally to prevent unwanted fluids flowing from
21 the surrounding formation into the borehole, and

1 similarly, to prevent fluids from within the
2 borehole escaping into the surrounding formation.

3

4 Referring to Fig. 1 there is shown a conventional
5 borehole 10 that has been drilled into a formation
6 12. It should be noted that Fig. 1 is not to scale.
7 Borehole 10 is drilled with a relatively large
8 diameter at or near surface 14, and it will be
9 appreciated that surface 14 could be below sea
10 level.

11

12 A relatively large outer diameter (OD) casing 16 is
13 then inserted into borehole 10 and cemented into
14 place using cement 18 in a conventional manner. The
15 cementing process typically involves filling an
16 annulus between the casing 16 and the surrounding
17 formation 12 with the cement 18 by pumping the
18 cement 18 into the casing 16 followed by a rubber or
19 other plug (not shown) on top of the cement 18.
20 Thereafter, drilling fluid or the like is pumped
21 down the casing 16 above the plug and the cement 18
22 is pushed out of the bottom of the casing 16 and up
23 into the annulus between the casing 16 and the
24 formation 12, as shown in Fig. 1. Pumping of
25 drilling fluid (and thus the cement 18) is stopped
26 when the plug reaches the bottom of the casing 16
27 and the borehole 10 must be left, typically for
28 several hours, whilst the cement sets.

29

30 Thereafter, a smaller diameter borehole 20 is
31 drilled through the cement 18 into the formation 12
32 and a subsequent casing 22 of smaller OD than the

1 casing 16 is passed through the casing 16 above and
2 the borehole 20. The diameter of the drill bit that
3 is used to drill borehole 20 is typically smaller
4 than the drill bit used to drill borehole 10, and is
5 typically smaller than an inside diameter (ID) of
6 the casing 16. Casing 22 is then cemented into
7 place using cement 24 in the conventional manner, as
8 described above. The OD of the subsequent casing 22
9 is limited by the inner diameter of the preceding
10 casing 16. The cement 24 is then left for a further
11 period of several hours to set.

12

13 A smaller diameter borehole 26 is then drilled into
14 the cement 24 and into the formation 12, and another
15 casing 28 is then passed through borehole 26 and the
16 casing 22 above. As before, the diameter of the
17 drill bit used to drill borehole 26 is typically
18 smaller than the drill bit used to drill boreholes
19 10, 20, and typically smaller than the ID of the
20 casing 22. Casing 28 is then cemented into place
21 using cement 30 in the conventional manner described
22 above. The cement 30 is typically left for a
23 further period of several hours to set. The ID of
24 the casing 22 thus limits the OD of casing 28.

25

26 Finally, a smaller diameter borehole 32 is drilled
27 into cement 30 and into formation 12, and another
28 casing 34 of smaller OD than casing 28 is passed
29 through casing 28. Again, the diameter of the drill
30 bit used to drill borehole 32 is smaller than those
31 used to drill the preceding boreholes 10, 20, 26,
32 and smaller than the ID of casing 28. Cement 36 is

1 then used to secure casing 34 within borehole 32
2 using the conventional manner described above. The
3 cement 36 is typically left for a further period of
4 several hours to set.

5
6 Thus, the casings 16, 22, 28, 34 are cascaded with
7 the diameters of the successive portions of casing
8 reducing as the depth of the borehole 10, 20, 26, 32
9 increases. It will be appreciated that the depth of
10 the borehole 10, 20, 26, 32 may be in the order of
11 several kilometres and the example shown in Fig. 1
12 is representative only.

13
14 The successive reduction in diameter of casing
15 results in a casing with a relatively small ID near
16 the bottom of the borehole 32 at or near a formation
17 payzone. The narrow ID could limit the amount of
18 hydrocarbons that can be recovered. In addition,
19 the relatively large diameter borehole 10 at the top
20 of the well involves increased costs due to the
21 large drill bits required, heavy equipment for
22 handling the larger casing, and increased volumes of
23 drill fluid that are required.

24
25 Once the casing portions 16, 22, 28, 34 have been
26 cemented into place, the borehole is then
27 "completed". This involves installing a completion
28 string 38 within the IDs of the casing portions 16,
29 22, 28, 34. The OD of the completion string 38 is
30 thus limited by the ID of the lowermost casing 34,
31 which in turn is limited by the IDs of the casings
32 16, 22, 28 above, and this can limit the amount of

1 hydrocarbons that can be recovered from a reservoir
2 40. The completion string 38 is typically of a
3 corrosion resistant material as corrosive chemicals
4 in the formation 12 and/or the reservoir 40 such as
5 H₂S can be mixed with the hydrocarbons from the
6 reservoir 40 flowing up through the string 38 to the
7 surface 14. The flow of hydrocarbons is indicated
8 schematically by arrows 42 in Fig. 1.

9
10 A packer 44 or the like is used at or near a lower
11 end of the lowermost casing 34 to isolate the
12 annulus and thus prevent hydrocarbons from flowing
13 up it. Also, a safety valve (not shown) is
14 typically located in the completion string 38 at or
15 near an upper end thereof, and is used to prevent
16 the flow of hydrocarbons to the surface in the event
17 of an emergency, as is known in the art. The
18 completion string 38 may also contain various flow
19 control devices to control the flow of hydrocarbons,
20 and downhole sensing and measuring apparatus to
21 monitor the flow rate, temperature and other
22 parameters of the produced fluids.

23
24 According to a first aspect of the present invention
25 there is provided a method of drilling and casing a
26 borehole, the method comprising the steps of a)
27 drilling a portion of the borehole into a formation,
28 b) providing an expandable tubular member, c)
29 running the tubular member into the portion of the
30 borehole, and d) radially expanding the member.

31

1 The method preferably includes the additional steps
2 of drilling one or more further portions of the
3 borehole extending from the existing portion of the
4 borehole, providing one or more further expandable
5 members, running the or each expandable member into
6 the or each further portions of the borehole, and
7 radially expanding the or each member in the or each
8 further portion of the borehole. This process can
9 then be repeated until the required depth of the
10 overall borehole is reached.

11

12 Preferably, the or each portion of the borehole is
13 drilled at approximately the same diameter as the
14 existing portion(s) of the borehole. Thus, all
15 boreholes are drilled and cased at substantially the
16 same diameter. This is advantageous because it
17 requires only a single sized drill bit to be used
18 instead of a number of different sized bits, and
19 also reduces the amount of time spent in drilling
20 and casing as there is no requirement to change to
21 different sized bits as the borehole increases in
22 depth.

23

24 The or each portion of the borehole typically
25 extends the borehole into the formation from the or
26 each existing portion. Alternatively, or
27 additionally, the or each portion of the borehole
28 may comprises one or more lateral and/or horizontal
29 boreholes drilled from the or each existing
30 borehole.

31

1 According to a second aspect of the present
2 invention there is provided apparatus for casing a
3 borehole, the apparatus comprising a length of
4 expandable tubular member, and an expander device
5 that is capable of radially expanding the member in
6 the borehole.

7
8 A drill bit is typically used to drill the or each
9 portion of the borehole into the formation. The
10 drill bit is typically provided with one or more
11 cutting elements that are preferably capable of
12 assuming a retracted configuration and an extended
13 configuration. In the retracted configuration, the
14 drill bit can be passed through expandable members
15 that have been expanded into contact with the
16 borehole. In the expanded configuration, the drill
17 bit can be used to drill a borehole below an
18 expandable member that has been previously
19 installed. An underreamer may be used, for example.

20
21 Alternatively, a single diameter drill bit can be
22 used together with an underreamer.

23
24 The or each expandable tubular member can be of a
25 length that is substantially the same length as the
26 or each portion of the borehole. This provides the
27 advantage that the entire length of the or each
28 portion of the borehole can be cased using the same
29 member. The or each length of expandable tubular
30 member can be provided by coupling discrete lengths
31 of expandable tubular member together (e.g. using

1 screw threads), or by using a roll, reel, coil or
2 the like of expandable tubular member.
3 Alternatively, the or each length of tubular member
4 may comprise a plurality of discrete lengths that
5 are inserted into the or each portion of the
6 borehole in an overlapping arrangement so that an
7 upper end of a subsequent member overlaps a lower
8 end of a previous member.

9
10 The or each expandable tubular member is typically
11 radially expanded until at least a portion of an
12 outer surface of the member contacts an inner
13 surface of the or each portion of the borehole. It
14 will be appreciated that the outer surface of the
15 member need not contact the or each portion of the
16 borehole. For example, the expandable tubular
17 member may be provided with a friction and/or
18 sealing material (e.g. rubber) on its outer surface,
19 where the material typically contacts the or each
20 portion of the borehole. Alternatively, the
21 expandable tubular member (with or without a
22 friction and/or sealing material) can be radially
23 expanded within the or each portion of the borehole
24 so that an annulus is created between an outer
25 surface of the member and the or each portion of the
26 borehole, the annulus then being filled with cement
27 to hold the member in place.

28
29 Also, one or more spacers or the like may be used
30 between the or each expandable tubular member and
31 the or each portion of the borehole.

32

1 The method typically includes one, some or all of
2 the additional steps of providing an expander
3 device, and running the expander device into the
4 expandable tubular member to radially expand the
5 member.

6
7 Optionally, the method includes one, some or all of
8 the additional steps of resting the or each
9 expandable tubular member on a portion of the
10 expander device, and pushing or pulling the expander
11 device through the member to radially expand the
12 member in the or each portion of the borehole.

13
14 Optionally, the method includes the additional step
15 of anchoring at least a portion of the member,
16 typically at or near a starting position of the
17 expander device.

18
19 The method typically includes the additional steps
20 of providing a drill string, coiled tubing string or
21 the like, and attaching the expander device to the
22 string.

23
24 Optionally, the method includes one, some or all of
25 the additional steps of providing a corrosion
26 resistant expandable tubular member, running the
27 corrosion resistant expandable tubular member into
28 the or each portion of the borehole, and radially
29 expanding the corrosion resistant member.

30
31 The corrosion resistant member is typically located
32 within the expandable tubular member. The corrosion

1 resistant member is typically radially expanded
2 until a portion thereof (e.g. an outer surface)
3 contacts the expandable tubular member. It will be
4 appreciated that the corrosion resistant member need
5 not contact the expandable tubular member. A spacer
6 or the like may be used therebetween, or a friction
7 and/or sealing material applied to the outer surface
8 of the corrosion resistant tubular member. Also,
9 cement may be used between the members.

10

11 The corrosion resistant expandable tubular member is
12 typically of a length that is substantially the same
13 length as the or each portion of the borehole and/or
14 the or each expandable tubular member. This
15 provides the advantage that the entire length of the
16 or each portion of the borehole can be cased using
17 the same member. The length of the or each
18 corrosion resistant expandable tubular member can be
19 provided by coupling discrete lengths of corrosion
20 resistant expandable tubular members together (e.g.
21 using screw threads), or by using a roll, coil, reel
22 or the like of corrosion resistant expandable
23 tubular member. Alternatively, the length of
24 corrosion resistant tubular member may comprise a
25 plurality of discrete lengths that are inserted into
26 the or each portion of the borehole in an
27 overlapping arrangement so that a lower end of an
28 upper member overlaps an upper end of a subsequent
29 member. The corrosion resistant tubular member
30 typically has a relatively thin wall thickness (e.g.
31 in the order of 5mm or less).

32

1 Typically, at least a portion of the outer surface
2 of the corrosion resistant tubular member contacts
3 an inner surface of the expandable tubular member,
4 although this is not essential.

5
6 The corrosion resistant tubular member is typically
7 required where the expandable tubular member is not
8 corrosion resistant so that the hydrocarbons and
9 other production fluids such as corrosive agents can
10 flow up the corrosion resistant tubular member to
11 the surface. Of course, the original expandable
12 tubular member may be of a corrosion resistant
13 material (or coated therewith) and thus there would
14 be no requirement for a second member of corrosion
15 resistant material. Additionally, the expandable
16 tubular member and/or the corrosion resistant
17 tubular member obviate the need to have an internal
18 completion string to facilitate the recovery of
19 hydrocarbons and eliminate an annulus between the
20 completion string and the casing.

21
22 Preferably, the method includes the additional step
23 of providing a service string within the expandable
24 tubular member. The service string is typically
25 required as there is no annulus between the
26 conventional completion string and the casing that
27 is typically used for control cables and the like
28 that control operation of various downhole tools and
29 apparatus (e.g. packers, flow control devices,
30 safety valves or the like), and electrical cables,
31 wires etc.

32

1 The apparatus optionally includes a corrosion
2 resistant tubular member. This member serves to
3 facilitate the flow of hydrocarbons from a
4 reservoir, well or the like to the surface.

5
6 The apparatus preferably includes a service string
7 or the like. The service string is typically
8 located within the expandable and/or corrosion
9 resistant member and is typically used as a conduit
10 to house cables, wires and the like that are
11 typically used to control downhole tools, apparatus
12 and instruments. The service string may be provided
13 with downhole apparatus and instruments (e.g. flow
14 meters, temperature sensors etc).

15
16 The recovered hydrocarbons typically flow up an
17 annulus between the service string and the
18 expandable tubular member and/or the corrosion
19 resistant tubular member.

20
21 The service string typically comprises a corrosion
22 resistant tubular member. However, the service
23 string may comprise any downhole tubular, such as a
24 string of casing, liner or the like. The service
25 string may comprise a roll or coil of tubing, or can
26 be discrete lengths of preferably corrosion
27 resistant tubular members that are coupled together
28 (e.g. using screw threads). The corrosion resistant
29 tubular member typically has a relatively thin wall
30 thickness (e.g. of around 5mm or less).

31

1 The or each tubular member is preferably
2 manufactured from a ductile material. Thus, the or
3 each tubular member is capable of sustaining plastic
4 deformation.

5
6 Typically, the or each tubular member is a casing,
7 liner, drill pipe, pipeline, conduit or the like.

8
9 The expander device is typically manufactured from
10 steel, a steel alloy, tungsten carbide etc.
11 Alternatively, the expander device may be
12 manufactured from ceramic, or a combination of
13 steel, ceramic, tungsten carbide etc. The expander
14 device is optionally flexible. The expander device
15 is typically of a material that is harder than the
16 member that is has to expand. It will be
17 appreciated that only the portion(s) of the expander
18 device that come into contact with the member need
19 be of a harder material and/or coated therewith.

20
21 The expander device is optionally provided with at
22 least one seal. The seal typically comprises at
23 least one O-ring.

24
25 The expander device is typically pushed or pulled
26 through the or each tubular member, pipeline,
27 conduit or the like using fluid pressure.
28 Alternatively, the device may be pigged along the or
29 each tubular member or the like using a conventional
30 pig or tractor. The device may also be pushed using
31 a weight (from the string for example), or may be
32 pulled through the or each tubular member or the

1 like (using drill pipe, rods, coiled tubing, a
2 wireline or the like).

3

4 The or each tubular member is optionally temporarily
5 anchored at an upper or lower end thereof using a
6 mechanical or other anchoring device (e.g. a slip or
7 packer), and facilitates radial expansion thereof.

8

9 An outer surface of the or each tubular member may
10 be provided with a friction and/or sealing material
11 that enhances the grip on the borehole or other
12 member. The formation typically comprises one or
13 more types of a resilient material.

14

15 Embodiments of the present invention shall now be
16 described, by way of example only, with reference to
17 the accompanying drawings in which:

18 Fig. 1 is a schematic representation of a prior
19 art method of drilling and casing a borehole;

20 Fig. 2 is an exemplary embodiment of apparatus
21 for casing a borehole;

22 Fig. 3a is a front elevation showing a first
23 configuration of a formation that can be
24 applied to an outer surface of a portion of the
25 apparatus of Fig. 2;

26 Fig. 3b is an end elevation of the formation of
27 Fig. 3a;

28 Fig. 3c is an enlarged view of a portion of the
29 formation of Figs 3a and 3b showing a profiled
30 outer surface;

31 Fig. 4a is a front elevation of an alternative
32 formation that can be applied to an outer

1 surface of a portion of the apparatus of Fig.
2 2; and
3 Fig. 4b is an end elevation of the formation of
4 Fig. 4a.

5
6 Referring to the drawings, Fig. 2 shows a particular
7 embodiment of apparatus for casing a borehole 50
8 that has been drilled into a formation 52 as is
9 known in the art. The borehole 50 generally
10 facilitates the recovery of hydrocarbons (or other
11 fluids) from a reservoir or pay zone (not shown in
12 Fig. 2).

13
14 Like conventional methods for drilling boreholes,
15 borehole 50 is made up of a number of individually
16 drilled portions of borehole, illustrated in Fig. 2
17 as boreholes 50a to 50e. It will be appreciated
18 that Fig. 2 is not to scale and shows only a portion
19 of the overall borehole 50 and the apparatus, and
20 the number of individual portions of borehole 50a to
21 50e that are required will vary depending upon the
22 length or depth of the overall borehole 50.

23
24 However, unlike conventional methods, the overall
25 borehole 50 is drilled at a single diameter along
26 its entire length or depth. This is achieved by
27 drilling subsequent portions of borehole 50b to 50e
28 through the first portion of borehole 50a at
29 substantially the same diameter as the first portion
30 of borehole 50a. A single diameter bit that is
31 provided with one or more cutting elements can be
32 used, where the or each cutting element is capable

1 of being moved between a retracted configuration and
2 an extended configuration. In this way, the drill
3 bit in the retracted configuration can be inserted
4 through the first portion of borehole 50a that has
5 already been drilled and cased, and then the or each
6 cutting element can be moved to the extended
7 configuration (e.g. by applying fluid pressure to
8 the bit). Thus, the subsequent portions of the
9 borehole 50b to 50e drilled can have substantially
10 the same diameter as the preceding portions of the
11 borehole 50a to 50d.

12
13 The apparatus includes a length of expandable casing
14 54 that is preferably a single length of casing that
15 is substantially the same length (or depth) as each
16 individual portion of the borehole 50a to 50e. The
17 casing 54 is shown in Fig. 2 as a number of casing
18 portions of a discrete length with an overlap
19 between each portion. However, it is possible to
20 have the casing 54 made from a single piece of
21 casing so that there is no overlap, although it is
22 also possible to have a number of casing portions
23 that are coupled together (e.g. by welding or screw
24 threads) so that there is no overlap between
25 successive casing portions. The casing 54 may be in
26 the form of a roll, reel or coil of casing as is
27 known in the art.

28
29 Casing 54 is preferably manufactured from a ductile
30 material so that it is capable of sustaining plastic
31 and/or elastic deformation. Casing 54 is typically

1 of carbon steel or a corrosion resistant alloy for
2 example.

3

4 In use, the first portion of the borehole 50a is
5 initially drilled so that the entire length or depth
6 of the first portion of the borehole 50a is of
7 substantially the same diameter. The diameter is
8 typically slightly greater than an outer diameter
9 (OD) of the casing 54 in an unexpanded state. The
10 casing 54 is typically capable of sustaining plastic
11 deformation to expand its OD by around 10% at least,
12 although radial plastic deformation in the order of
13 20% or more is possible. Thus, the diameter of the
14 first portion of the borehole 50a (and thus the
15 overall borehole 50) will be dependent upon the
16 material used for the casing 54 and also the
17 percentage of radial plastic deformation. It will
18 be appreciated that use of the term radial plastic
19 deformation is understood to be the use of an
20 expander device (not shown) that is pushed or pulled
21 through the casing 54 to impart a radial expansion
22 force to the casing so that both the ID and the OD
23 of the casing 54 increases.

24

25 Once the first portion of the borehole 50a has been
26 drilled, it is typically lined or cased to prevent
27 it from collapsing. In its simplest embodiment, a
28 length of expandable casing 54a is inserted into the
29 first portion of the borehole 50a. The length of
30 the casing 54a is substantially the same as the
31 depth or length of the first portion of the borehole
32 50a. After the casing 54a has been run into the

1 first portion of the borehole 50a, an expander
2 device is then forced through the casing 54a to
3 radially expand at least a portion thereof, and
4 preferably the entire length, so that the outer
5 surface of the casing 54 preferably contacts the
6 inner wall of the first portion of the borehole 50a.
7 It will be appreciated that the outer surface of
8 casing 54a need not contact the inner wall of the
9 first portion of the borehole 50a, as will de
10 described.

11

12 The length of casing 54a may be in a number of
13 different forms, for example, the length of casing
14 54a could be from a roll, reel or coil of expandable
15 tubing. Alternatively, the casing 54a can be made
16 up from a plurality of discrete lengths of casing
17 that are coupled together (e.g. by welding, screw
18 threads or the like), or overlapped at each end.

19

20 It is preferred, but not essential, that the entire
21 length of the casing 54a is expanded in one pass of
22 an expander device (not shown) through the casing
23 54a. The expander device is typically a cone that
24 is forced through the casing 54a to impart a radial
25 expansion force to the casing 54a. The device can
26 be of metal or a metal alloy (e.g. steel, tungsten
27 carbide), ceramic or a combination of these
28 materials and typically has an OD that is
29 substantially the same as or slightly less than the
30 final required ID of the (expanded) casing 54a. In
31 this way, the first portion of the borehole 50a can

1 be cased in one trip of the device through the
2 casing 54a.

3

4 The pliable casing 54a undergoes plastic deformation
5 when expanded by the expander device as it is
6 propelled, pushed or pulled through the casing 54a.

7 The expander device can be propelled along the
8 casing 54a in a similar manner to a pipeline pig and
9 may be pushed (using weight or fluid pressure for
10 example) or pulled (using drill pipe, rods, coiled
11 tubing, a wireline or the like).

12

13 The expander device is typically attached to a drill
14 string, coil tubing string or the like and can be
15 inserted into a lower part of the casing 54a that
16 has been pre-expanded to house the device.

17 Thereafter, the device is pulled through the casing
18 54a to impart a radial expansion force by pulling
19 the drill string, coiled tubing string etc out of
20 the casing 54a. Where the expander device is
21 located in a pre-expanded portion of the casing 54a,
22 the casing 54a can be rested on top of the device
23 and lowered into the first portion of the borehole
24 50a using the drill string, coiled tubing string or
25 the like.

26

27 Alternatively, the expander device can be propelled
28 or pushed through the casing 54a using a pig,
29 tractor, fluid pressure or the like. It is possible
30 that the expander device can be located at the top
31 of the casing and propelled (using a tractor) or
32 pushed (using fluid pressure, a drill string, or

1 weight from the string) through the casing 54a to
2 impart a radial expansion force thereto.

3

4 The casing 54a may need to be temporarily anchored
5 in the first portion 50a of the borehole 50 using a
6 device, such as a packer, slips or the like.

7 However, where the expander device includes an
8 inflatable element (e.g. a packer), then the
9 inflatable element can be inflated in the pre-
10 expanded portion (or elsewhere) thus forcing it
11 radially outwards into contact with the first
12 portion 50a of the borehole 50 and this provides an
13 anchor for pulling the device through the casing
14 54a. The expander device (e.g. a cone) can be
15 releasably attached to the inflatable element so
16 that the inflatable element can be left in the
17 casing 54a to act as an anchor during expansion
18 thereof.

19

20 The expandable casing 54a does not require to be
21 cemented into place as it is typically held against
22 the first portion 50a of the borehole 50 due to
23 physical contact between an outer surface of the
24 casing 54a and an inner wall of the first portion
25 50a of the borehole 50, although cementing remains
26 an option. The casing 54a need not contact the
27 borehole 50 itself; it may be provided with a
28 friction and/or sealing material, or other type of
29 spacer or seal, between the casing 54a and the first
30 portion 50a of the borehole 50. Thus, significant
31 savings in terms of rig time and costs are provided
32 as it is no longer necessary to cement each length

1 of conventional casing into place, the cement
2 typically being left for several hours to cure. As
3 each casing is of a different diameter, a borehole
4 of equivalent or slightly larger diameter must be
5 drilled into the formation for each diameter of
6 casing which is then cemented into place, taking
7 several hours to cure.

8

9 Once the first portion 50a of the borehole 50 has
10 been drilled and the casing 54a installed, as
11 described above, a second portion 50b of the
12 borehole 50 is then drilled. The second portion 50b
13 of the borehole 50 can be drilled using an
14 expandable bit (e.g. a drill bit that is capable of
15 assuming two different configurations). The
16 expandable bit typically has a plurality of cutting
17 elements that can be moved between first and second
18 configurations. In the first configuration, the
19 cutting elements are typically retracted so that the
20 drill bit can be passed through the bore of
21 previously drilled boreholes and/or pre-installed
22 casings, liners etc. Once the bit has passed
23 through the bores, the cutting elements can then be
24 extended (e.g. by fluid pressure, centrifugal force
25 or the like) to assume a cutting diameter that is
26 slightly greater than the final or expanded outer
27 diameter of the casing, liner etc.

28

29 Alternatively, the or each borehole portion 50b to
30 50e can be drilled using a drill bit of a fixed
31 diameter, and then an underreamer used to enlarge

1 the bore below a pre-installed portion of casing to
2 allow a second casing to be installed therebelow.

3

4 Thus, the second portion 50b of the borehole 50 is
5 drilled at substantially the same diameter as the
6 first portion 50a of the borehole 50. Thus, there
7 is no requirement to provide drill bits of varying
8 cutting diameter to produce boreholes that reduce in
9 diameter as the length or depth of the borehole
10 increases, thus saving costs. Further, there is no
11 requirement to provide casing or liner having
12 different diameters, again saving costs. Further
13 cost and time savings can be made as there is no
14 requirement to change drill bits to vary the cutting
15 diameter and the time taken to perform this.

16

17 Having drilled the second portion 50b of the
18 borehole 50, a second casing 54b, similar to casing
19 54a, is then installed and expanded into place as
20 described above with reference to casing 54a. This
21 has significant advantages as the casing 54a, 54b
22 can be expanded sufficiently so that an outer
23 surface 54s of each casing 54a, 54b contacts an
24 inner wall of the borehole portions 50a, 50b.
25 Consequently, the casing 54a, 54b is held in place
26 due to frictional contact with the wall of the
27 borehole portions 50a, 50b. Indeed, the casings
28 54a, 54b can be expanded sufficiently so that they
29 deform into the formation 52 and remain in place due
30 to compression of the formation 52. This is
31 advantageous because the casing 54a, 54b can be held
32 in place without the use of cement. This, there is

1 no requirement to cement the casing 54a, 54b in
2 place, thereby saving time and costs because the
3 borehole portions 50a, 50b does not require to be
4 left for several hours for each casing 54a, 54b to
5 allow the cement to cure before further boreholes
6 can be drilled.

7
8 A third portion 50c of the borehole 50 is then
9 drilled and cased using casing 54c in a similar
10 manner to that described above. Further portions
11 50d, 50e of the borehole 50 can then be drilled and
12 cased using casing 54d, 54e and so on until the
13 overall borehole 50 is at the required depth or
14 length. Thus, the entire borehole 50 is drilled at
15 substantially the same diameter over the full length
16 or depth. Further advantages of embodiment of the
17 present invention is that the entire length or depth
18 of the overall borehole 50 can have a diameter that
19 is sufficient to facilitate effective and non-
20 restricted production of hydrocarbons and other
21 fluid therefrom. This means that production from
22 the borehole 50 can be increased, without adding to
23 the costs and providing time savings in gaining
24 access to the pay zone.

25
26 It will be appreciated that an upper end of the
27 subsequent casings 54b to 54e typically overlap a
28 lower end of the previously installed casing (e.g.
29 casing 54a), as shown in Fig. 2.

30
31 It will be noted that drilling the borehole 50 at a
32 single diameter over its entire length using

1 individual borehole portions 50a to 50e of
2 substantially the same diameter, has other
3 advantages over the conventional method described
4 with reference to Fig. 1. In particular, the large
5 drill bits and heavy equipment that are typically
6 used towards the upper end of the borehole are not
7 required, thus significantly reducing the costs.
8 Other benefits and advantages include environmental
9 benefits as less rock/cuttings are removed from the
10 borehole that require to be disposed of. Also, only
11 a borehole of one diameter is required. Thus, there
12 is no requirement to drill a borehole of a first
13 diameter using a relatively large drill bit and then
14 drilling subsequent lower boreholes with drill bits
15 that gradually reduce in diameter as the depth of
16 the borehole increases. This significantly reduces
17 the costs as less rig time is required because the
18 requirement to periodically change a drill bit to a
19 different sized bit is obviated. Furthermore, only
20 a single-sized borehole is required and thus a
21 plurality of different sized drill bits are not
22 generally required, which also reduces costs. The
23 rig time for drilling the borehole is substantially
24 reduced with respect to conventional methods, as
25 only a single diameter hole need be drilled over the
26 entire length of the borehole.

27

28 Thus, the method of the present invention provides
29 significant costs and timesavings as only a single
30 diameter borehole need be drilled, and the borehole
31 can be cased using a casing that has a substantially
32 constant diameter over its entire length. As there

1 is no requirement to drill, case and then cement in
2 a cascaded manner, the savings in terms of costs and
3 rig time, rig power, rig size etc are considerable
4 over conventional methods.

5

6 The outer surface of the casing 54 may optionally be
7 provided with a friction and/or sealing material.

8 In this case, the friction and/or sealing material
9 can be used to enhance the grip of the outer surface
10 of the casing on the inner wall of the or each
11 portion 50a to 50e of the borehole 50. Any suitable
12 type of rubber or other resilient material can be
13 used for this purpose.

14

15 Referring to Fig. 3, there is shown a formation
16 generally designated 70, of a friction and/or
17 sealing material that may be applied to an outer
18 surface 54s of the casing 54 thereof. The formation
19 70 typically comprises first and second bands 72, 74
20 that are axially spaced-apart along a longitudinal
21 axis of the casing 54. The first and second bands
22 72, 74 are typically axially spaced by some
23 distance, for example 3 inches (approximately 76mm).
24 The first and second bands 72, 74 are preferably
25 annular bands that extend circumferentially around
26 the outer surface 54s of the casing 54, although
27 this configuration is not essential. The first and
28 second bands 72, 74 typically comprise 1-inch wide
29 (approximately 26mm) bands of a first resilient
30 material (e.g. a first type of rubber). The
31 formation 70 need not extend around the full
32 circumference of the surface 54s.

1

2 Located between the first and second bands 72, 74 is
3 a third band 76 of a second resilient material (e.g.
4 a second type of rubber). The third band 76
5 preferably extends between the first and second
6 bands 72, 74 and is thus typically 3 inches
7 (approximately 76mm) wide.

8

9 The first and second bands 72, 74 are typically of
10 the same depth as the third band 76, although the
11 first and second bands may be of a slightly larger
12 depth.

13

14 The first type of rubber (i.e. first and second
15 bands 72, 74) is preferably of a harder consistency
16 than the second type of rubber (i.e. third band 76).
17 The first type of rubber is typically 90 durometer
18 rubber, whereas the second type of rubber is
19 typically 60 durometer rubber. Durometer is a
20 conventional hardness scale for rubber.

21

22 The particular properties of the rubber or other
23 resilient material may be of any suitable type and
24 the hardnesses quoted are exemplary only. It
25 should also be noted that the relative dimensions
26 and spacing of the first, second and third bands 72,
27 74, 76 are exemplary only and may be of any suitable
28 dimensions and spacing.

29

30 As can be seen from Fig. 3c in particular, an outer
31 face 76s of the third band 76 can be profiled. The
32 outer face 76s is ribbed to enhance the grip of the

1 third band 76 on the borehole in which the casing 54
2 is located. It will be appreciated that an outer
3 surface of the first and second bands 72, 74 may
4 also be profiled (e.g. ribbed). The ribbed profile
5 also helps when the casing 54 is expanded as it
6 provides a space into which the compressed rubber
7 can extend or deform into, as rubber is generally
8 incompressible.

9
10 The two outer bands 72, 74 being of a harder rubber
11 provide a relatively high temperature seal and a
12 back-up seal to the relatively softer rubber of the
13 third band 76. The third band 76 typically provides
14 a lower temperature seal.

15
16 The two outer bands of rubber 72, 74 are provided
17 with a number of circumferentially spaced-apart
18 notches 78. In the embodiment shown, four
19 equidistantly spaced notches 78 are provided, and as
20 can be seen from Fig. 3b in particular, the notches
21 78 do not extend through the entire depth of the
22 rubber bands 72, 74. The notches 78 are used
23 because the bands 72, 74 are of a relatively hard
24 rubber material and this may stress, crack or break
25 when the outer diameter of the casing 54 is radially
26 expanded. The notches 78 provide a portion of the
27 bands 72, 74 that is of lesser thickness than the
28 rest of the bands 72, 74 and this portion can
29 stretch when the casing 54 is expanded. The
30 stretching of this portion substantially prevents
31 the bands 72, 74 from cracking or breaking when the
32 casing 54 is expanded. The notches 78 also provide

1 a space into which the rubber may deform or expand
2 into when the casing 54 is expanded.

3

4 In use, the formation 70 is applied to the outer
5 surface 54s of the (unexpanded) expandable casing
6 54. The formation 70 may be applied at axially
7 spaced-apart locations along the length of the
8 casing 54, the spacing and number of formations 70
9 being chosen to suit the particular application.

10

11 An alternative formation 80 that can be applied to
12 the outer surface 54s of the casing 54 is shown in
13 Figs 4a and 4b. The alternative formation 80 is in
14 the form of a zigzag. In this embodiment, the
15 formation 80 comprises a single (preferably annular)
16 band of resilient material (e.g. rubber) that is,
17 for example, of 90 durometers hardness and about 2.5
18 inches (approximately 28mm) wide by around 0.12
19 inches (approximately 3mm) deep.

20

21 To provide a zigzag pattern and hence increase the
22 strength of the grip and/or seal that the formation
23 80 provides in use, a number of slots 82a, 82b (e.g.
24 20 in number) are milled into the band of rubber.
25 The slots 82a, 82b are typically in the order of 0.2
26 inches (approximately 5mm) wide by around 2 inches
27 (approximately 50mm) long.

28

29 The slots 82a are milled at around 20
30 circumferentially spaced-apart locations, with
31 around 18° between each along one edge 84a of the
32 band. The process is then repeated by milling

1 another 20 slots 82b on the other side 84b of the
2 band, the slots 82b on the other side 84b being
3 circumferentially offset by 9° from the slots 82a on
4 the first side 84a. The slots 82a, 82b also provide
5 a space into which the rubber of the formation 80
6 can expand or deform into when the casing 54 is
7 expanded.

8
9 In use, the formation 80 is applied to the outer
10 surface 54s of the expandable casing 54, as with
11 formation 70. The formation 80 may be applied at a
12 plurality of axially spaced-apart locations along
13 the length of the casing 54, the spacing and number
14 of formations 80 being chosen to suit the particular
15 application.

16
17 It is preferable that the casing 54 be made of a
18 corrosion resistant material so that the casing 54
19 can also be used as a production string up which
20 hydrocarbons from the reservoir may flow to the
21 surface. Of course, casing 54 may be coated with a
22 corrosion resistant material. However, where this
23 is not possible, it will be necessary to insert an
24 additional length of cladding 56 that is of a
25 corrosion resistant material inside the casing 54,
26 as shown in Fig. 2. It should be noted that the
27 corrosion resistant cladding 56 is not essential.

28
29 The cladding 56 is preferably also of a ductile
30 material that is also a corrosion resistant material
31 so that it can be inserted into the casing 54 and

1 radially expanded so that its OD contacts the ID of
2 the casing 54. In this way, the overall borehole 50
3 (or portions thereof) can be lined with casing 54
4 and clad with cladding 56 by installing the casing
5 54 as described above, and then the cladding 56 is
6 inserted into the casing 54 and then radially
7 expanded so that it contacts an inner surface of the
8 casing 54. Again, the cladding 56 need not contact
9 the casing 54 as spacers or the like may be
10 provided. Also, cement can optionally be used to
11 fill the annulus between the casing 54 and the
12 cladding 56.

13

14 Cladding 56 is typically relatively thin (e.g. with
15 a wall thickness of around 5mm or less) so that it
16 is easy to radially expand, and also so that it does
17 not adversely affect the size of the conduit through
18 which the recovered hydrocarbons flow to the
19 surface. Thus, the cladding 56 does not restrict
20 the flow rate of the recovered hydrocarbons or other
21 fluids.

22

23 It will be appreciated that the cladding 56 may be
24 provided with formation 70, formation 80 or the like
25 to provide a seal in the annulus 58 between the
26 cladding 56 and casing 54, as illustrated in Fig. 2.
27 It will be generally appreciated that a seal in the
28 annulus 58 will not be required where the cladding
29 56 is expanded to fully contact the casing 54 as
30 there will be no annulus. The seals provided by,
31 for example, formations 70, 80 or any conventional
32 method (e. g. a packer) prevent hydrocarbons from

1 the reservoir or well flowing up the annulus 58 and
2 being lost into the surrounding formation.

3

4 Thus, the method may include the additional step of
5 providing a length of cladding 56 where it is
6 required to have a corrosion resistant material in
7 the borehole 50 (e.g. if the casing 54 is not
8 corrosion resistant or provided with a corrosion
9 resistant coating). The cladding 56 can be the same
10 length as the overall borehole 50, but it will be
11 appreciated that the length of cladding 56 may
12 comprise a number of discrete portions, or may be in
13 the form of a coil, reel or roll for example. The
14 cladding 56 is then run into the casing 54 and
15 radially expanded. The cladding 56 can be radially
16 expanded in the same way as the casing 54 e.g. by
17 pushing, pulling or otherwise propelling the
18 expander device therethrough.

19

20 The conventional method of drilling and completing a
21 borehole generally provides a production annulus 46
22 between the production string 38 and the casing 34
23 (Fig. 1). The production annulus 46 is typically
24 used to run control lines, wires etc from the
25 surface to downhole, the lines etc being used for
26 many different purposes such as transmitting power
27 and data communications from the surface to
28 apparatus located downhole.

29

30 The production annulus 46 typically acts as a
31 service conduit also, that is it is usually used to
32 gain access for remedial and repair operations.

1 Also, the service conduit is used to house cabling
2 and downhole apparatus and instruments (e.g. flow
3 sensors, temperature sensors and associated cabling
4 etc) that monitor various parameters of the
5 recovered hydrocarbons.

6
7 The service conduit (i.e. production annulus 46) is
8 generally limited in size resulting in space and
9 design constraints for the type of apparatus,
10 instruments and cabling that can be inserted
11 therein. The size limitation also presents other
12 problems, such as making the annulus 46 difficult to
13 access and it is also difficult to install downhole
14 apparatus and instruments, cabling etc. The
15 apparatus, instruments and cabling are often damaged
16 as they are being run into the annulus 46, and there
17 is also difficulty in passing the apparatus etc
18 through pressure barriers such as packers.

19
20 If the apparatus or instruments fail or break down
21 during installation or use, they must be retrieved
22 from the annulus, which can be very expensive and
23 time consuming.

24
25 Referring to Fig. 2, it will be noted that an
26 annulus 58 is provided in the particular embodiment
27 shown in Fig. 2 and this can be used for the control
28 lines etc. However, there may be situations where
29 there is no annulus 58 between the cladding 56 and
30 the casing 54, for example where the casing 54 is
31 also corrosion resistant so that the cladding 56 is
32 not required, or where the cladding 56 is radially

1 expanded to fully contact the inner surface of the
2 casing 54 or cement is used to fill the annulus 58.

3

4 Thus, the present invention also provides a service
5 string 62 that is located within the cladding 56 in
6 the embodiment shown. It will be noted that the
7 service string 62 can be provided within the casing
8 54 where no cladding 56 is used. The service string
9 62 is of a relatively small OD so that it does not
10 provide an obstruction to the hydrocarbons that will
11 flow up an annulus 64 between the service string 62
12 and the cladding 56 (or casing 54).

13

14 The service string 62 can be a string of any
15 downhole tubular member, but is preferably in the
16 form of a coil, roll or reel so that it can be
17 easily dispensed and retrieved from the borehole 50.

18

19 The service string 62 is used to house the control
20 wires, lines etc and any other control or electrical
21 cables that are used to control or provide signals
22 to and from downhole apparatus. The service string
23 62 may incorporate the downhole apparatus and
24 instruments, such as flow sensors 66 or intra-well
25 sensors 68 etc. Thus, the service string 62 could
26 house cabling that is between the downhole sensors
27 66, 68 and the surface. The service string 62 may
28 also be used for chemical injection and gas lift.

29

30 Also, the annulus 64 may contain other downhole
31 apparatus or instruments, such as flow control
32 devices 69 or the like. Thus, the service string 62

1 can be used to house any cabling between the flow
2 control device 69 and the surface so that the device
3 69 or other apparatus can be controlled and
4 monitored.

5
6 Where a service string 62 is required, the method
7 typically includes the additional steps of providing
8 the service string 62 within the casing 54 or the
9 cladding 56. The service string 62 is typically
10 held within the casing 54 or the cladding 56 using
11 any conventional means, e.g. seals, a packer or the
12 like. The service string 62 can comprise a number
13 of discrete portions of drill string for example, or
14 could be a length of coiled tubing or the like.

15
16 Thus, the invention in certain embodiments provides
17 a method and apparatus for casing a borehole that
18 provides significant advantages over conventional
19 methods. In particular, the method and apparatus of
20 the invention in certain embodiments provide savings
21 in terms of costs and rig time, and also obviate the
22 need to drill different sized boreholes for each OD
23 of casing. Additionally, there is no requirement to
24 cement the casing into place as it is radially
25 expanded to contact the borehole and is generally
26 held in place due to a frictional contact between
27 the casing and the borehole.

28
29 The service string in certain embodiments offers
30 advantages over the conventional method because it
31 provides a housing for downhole apparatus and
32 instruments that can be pre-installed before the

1 string is run into the borehole. Thus, the
2 instruments, cabling etc are protected as they are
3 run into the borehole by the service string. Also,
4 if the instruments, apparatus etc within the service
5 string fail or break down, the service string can be
6 easily withdrawn from the borehole and the
7 instruments, apparatus etc repaired or replaced
8 before the string is run back into the borehole.

9
10 It will also be appreciated that embodiments of the
11 present invention facilitate easy repair of damaged
12 portions of casing, lining or cladding. The service
13 string (where used) would be pulled out of the
14 borehole, and a portion of casing, lining or
15 cladding inserted into the borehole. The portion of
16 casing, liner or cladding is located at or near the
17 damaged portion that is to be repaired, and
18 preferably straddles the damaged portion.
19 Thereafter, the portion of casing, liner or cladding
20 is then radially expanded using an expander device
21 or an inflatable element (e.g. a packer) so that the
22 portion of casing, liner or cladding is radially
23 expanded and thus overlays the damaged portion of
24 casing, liner or cladding. The entire length of the
25 casing, liner or cladding need not be fully
26 expanded, and the casing, liner or cladding can be
27 tied back to the damaged portion by expanding each
28 end thereof (e.g. using an inflatable packer).
29 However, the portion of casing, liner or cladding
30 that is not fully expanded will typically cause a
31 restriction in the path of the hydrocarbons (or
32 other fluids) that are being recovered, which could

1 limit the rate at which the hydrocarbons (or other
2 fluids) can be recovered.

3

4 The portion of casing or cladding that is used for
5 the repair is typically a thin-walled tubular with a
6 wall thickness of 5mm or less so that there is no
7 material change to the diameter of the annulus
8 created between the service string and the cladding
9 up which the hydrocarbons flow. Thus, there is no
10 adverse affect on the flow rate of the recovered
11 hydrocarbons.

12

13 Certain embodiments of the invention also provide
14 advantages, as repair or maintenance (e.g. remedial)
15 operations to the borehole, formation etc are
16 simpler because a relatively large diameter of
17 casing can be used along the entire length of the
18 borehole. In conventional systems, these types of
19 operation have to be performed from within the
20 completion string. Restrictions in the ID of the
21 completion string, for example due to safety valves,
22 sensors and the like, can make these operations
23 difficult. Certain embodiments of the present
24 invention provide an unrestricted ID of casing so
25 that the repair operations etc can be undertaken
26 more easily. Even where a service string is used
27 with the present invention, this is relatively small
28 and can be removed to facilitate the repair
29 operations etc, and thereafter replaced.

30

31 Modifications and improvements may be made to the
32 foregoing without departing from the scope of the

1 present invention. For example, the tubular members
2 described herein have been radially expanded using
3 an expander device that imparts a plastic
4 deformation to expand the member. It will be
5 generally appreciated that the members can undergo
6 radial expansion, where only a discrete length of
7 the member is expanded using an inflatable device
8 (e.g. a packer). Thereafter, the inflatable device
9 is moved to an unexpanded portion and inflated to
10 radially expand the next portion and so on.
11

1 CLAIMS

2

3 1. A method of drilling and/or casing a borehole,
4 the method comprising the steps of a) drilling a
5 portion (50a) of the borehole (50) into a formation
6 (52); b) providing an expandable tubular member
7 (54); c) running the expandable tubular member (54)
8 into the portion (50a) of the borehole (50); and d)
9 radially expanding the member (54).

10

11 2. A method according to claim 1, the method
12 including the additional steps of drilling one or
13 more further portions (50b to 50e) of the borehole
14 (50) extending from the existing portion (50a) of
15 the borehole (50), providing one or more further
16 expandable members (54b to 54e), running the or each
17 expandable member (54b to 54e) into the or each
18 further portions (50b to 50e) of the borehole (50),
19 and radially expanding the or each expandable member
20 (54b to 54e) in the or each further portions (50b to
21 50e) of the borehole (5).

22

23 3. A method according to claim 2, wherein the or
24 each further portion (50b to 50e) of the borehole
25 (50) is drilled at approximately the same diameter
26 as the or each existing portion(s) (50a to 50d) of
27 the borehole (50).

28

29 4. A method according to claim 2 or claim 3,
30 wherein the or each further portion (50b to 50e) of
31 the borehole (50) extends into the formation (52)
32 from the or each existing portion (50a to 50e).

1

2 5. A method according to any one of claims 2 to 4,
3 wherein the or each portion (50b to 50e) of the
4 borehole (50) comprises one or more lateral and/or
5 horizontal boreholes drilled from the or each
6 existing borehole (50a to 50d).

7

8 6. A method according to any preceding claim,
9 wherein the method includes the additional step of
10 providing a drill bit to drill the or each portion
11 (50a to 50e) of the borehole (50) into the formation
12 (52).

13

14 7. A method according to claim 6, wherein the
15 drill bit is provided with one or more cutting
16 elements that are capable of being moved between a
17 retracted configuration and an extended
18 configuration.

19

20 8. A method according to claim 7, the method
21 including the additional step of moving the cutting
22 elements between the retracted configuration and the
23 extended configuration.

24

25 9. A method according to claim 8, wherein the step
26 of moving the cutting elements includes the
27 additional step of applying pressurised fluid to the
28 drill bit.

29

30 10. A method according to claim 6, wherein a single
31 diameter drill bit is used to drill the or each
32 portion (50a to 50e) of the borehole (50).

1

2 11. A method according to claim 10, wherein the
3 method includes the additional steps of providing an
4 underreamer, running the underreamer into the or
5 each portion (50a to 50e) of the borehole (50), and
6 actuating the underreamer to increase the diameter
7 of the or each portion (50a to 50e) of the borehole
8 (50).

9

10 12. A method according to any preceding claim,
11 wherein the or each expandable tubular member (54a
12 to 54e) is radially expanded until at least a
13 portion of an outer surface (54s) of the member (54a
14 to 54e) contacts an inner surface of the or each
15 portion (50a to 50e) of the borehole (50).

16

17 13. A method according to any one of claims 1 to
18 11, wherein the expandable tubular member (54a to
19 54e) is radially expanded within the or each portion
20 (50a to 50e) of the borehole (50) so that an annulus
21 is created between an outer surface (54s) of the
22 member (54a to 54e) and the or each portion (50a to
23 50e) of the borehole (50), and the method includes
24 the additional step of filling the annulus with
25 cement to hold the member (54a to 54e) in place.

26

27 14. A method according to any preceding claim,
28 wherein the step of radially expanding the member
29 (54a to 54e) includes the additional steps of
30 providing an expander device, and running the
31 expander device into the expandable tubular member

1 (54a to 54e) to radially expand the member (54a to
2 54e).

3

4 15. A method according to claim 14, wherein the
5 step of running the expander device includes the
6 step of pushing and/or pulling the expander device
7 through the member (54a to 54e) to radially expand
8 the member (54a to 54e) in the or each portion (50a
9 to 50e) of the borehole (50).

10

11 16. A method according to claim 14 or claim 15,
12 wherein the method includes the additional step of
13 resting the or each expandable tubular member (54a
14 to 54e) on a portion of the expander device whilst
15 the member (54a to 54e) and device are run into the
16 or each portion (50a to 50e) of the borehole (50).

17

18 17. A method according to any one of claims 14 to
19 16, wherein the method includes the additional step
20 of anchoring at least a portion of the member (54a
21 to 54e) at or near a starting position of the
22 expander device.

23

24 18. A method according to any preceding claim, the
25 method including one, some or all of the additional
26 steps of e) providing a corrosion resistant
27 expandable tubular member (56); f) running the
28 corrosion resistant expandable tubular member (56)
29 into the or each portion (50a to 50e) of the
30 borehole (50); and g) radially expanding the
31 corrosion resistant expandable tubular member (56).

32

1 19. A method according to claim 18, wherein the
2 method includes repeating steps e) to f).

3 .

4 20. A method according to any preceding claim, the
5 method including the additional step of providing a
6 service string (62) within the expandable tubular
7 member (54) and/or the corrosion resistant
8 expandable tubular member (56).

9

10 21. Apparatus for casing a borehole , the apparatus
11 comprising at least one length of expandable tubular
12 member (54), and an expander device that is capable
13 of radially expanding the member (54) in the
14 borehole (50).

15

16 22. Apparatus according to claim 21, wherein the or
17 each expandable tubular member (54a to 54e) is of a
18 length that is substantially the same length as the
19 or each portion (50a to 50e) of the borehole (50).

20

21 23. Apparatus according to claim 21 or claim 22,
22 wherein the or each length of expandable tubular
23 member (54a to 54e) is provided by coupling discrete
24 lengths of expandable tubular member (54a to 54e)
25 together.

26

27 24. Apparatus according to claim 21 or claim 22,
28 wherein the or each length of expandable tubular
29 member (54) is provided from a roll, reel, coil or
30 drum of expandable tubular member (54).

31

1 25. Apparatus according to claim 21 or claim 22,
2 wherein the or each length of expandable tubular
3 member (54a to 54e) comprises a plurality of
4 discrete lengths that are inserted into the or each
5 portion (50a to 50e) of the borehole (50) in an
6 overlapping arrangement so that one end of a
7 subsequent member (54a to 54e) overlaps one end of a
8 previous member (54a to 54e).

9
10 26. Apparatus according to any one of claims 21 to
11 25, wherein the or each expandable tubular member
12 (54a to 54e) is provided with a friction and/or
13 sealing material (70, 80) on its outer surface.

14
15 27. Apparatus according to any one of claims 21 to
16 26, wherein the apparatus includes one or more
17 spacers located between the or each expandable
18 tubular member (54a to 54e) and the or each portion
19 (50a to 50e) of the borehole (50).

20
21 28. Apparatus according to any one of claims 21 to
22 27, wherein the or each expandable tubular member
23 (54a to 54e) is of a corrosion resistant material,
24 or coated therewith.

25
26 29. Apparatus according to any one of claims 21 to
27 28, wherein the apparatus includes at least one
28 corrosion resistant expandable tubular member (56)
29 located within the or each expandable tubular member
30 (54a to 54e).

31

1 30. Apparatus according to claim 29, wherein the
2 corrosion resistant expandable tubular member (56)
3 is of a length that is substantially the same length
4 as the or each portion (50a to 50e) of the borehole
5 (50) and/or the or each expandable tubular member
6 (54a to 54e).

7

8 31. Apparatus according to claim 29 or claim 30,
9 wherein the corrosion resistant expandable tubular
10 member (56) has a wall thickness in the order of 5mm
11 or less.

12

13 32. Apparatus according to any one of claims 29 to
14 31, wherein the apparatus includes a service string
15 (62).

16

17 33. Apparatus according to claim 32, wherein the
18 service string (62) is located within the expandable
19 tubular member (54a to 54e) and/or the corrosion
20 resistant expandable tubular member (56).

21

22 34. Apparatus according to claim 32 or claim 33,
23 wherein the service string (62) is used as a conduit
24 to house cables and wires that are used to control
25 downhole tools, apparatus and instruments.

26

27 35. Apparatus according to any one of claims 32 to
28 34, wherein the service string (62) is provided with
29 downhole tools, apparatus and instruments.

30

1 36. Apparatus according to any one of claims 32 to
2 35, wherein the service string (62) comprises a
3 corrosion resistant tubular member (56).

4

5 37. Apparatus according to any one of claims 32 to
6 36, wherein the service string (62) has a wall
7 thickness in the order of 5mm or less.

8

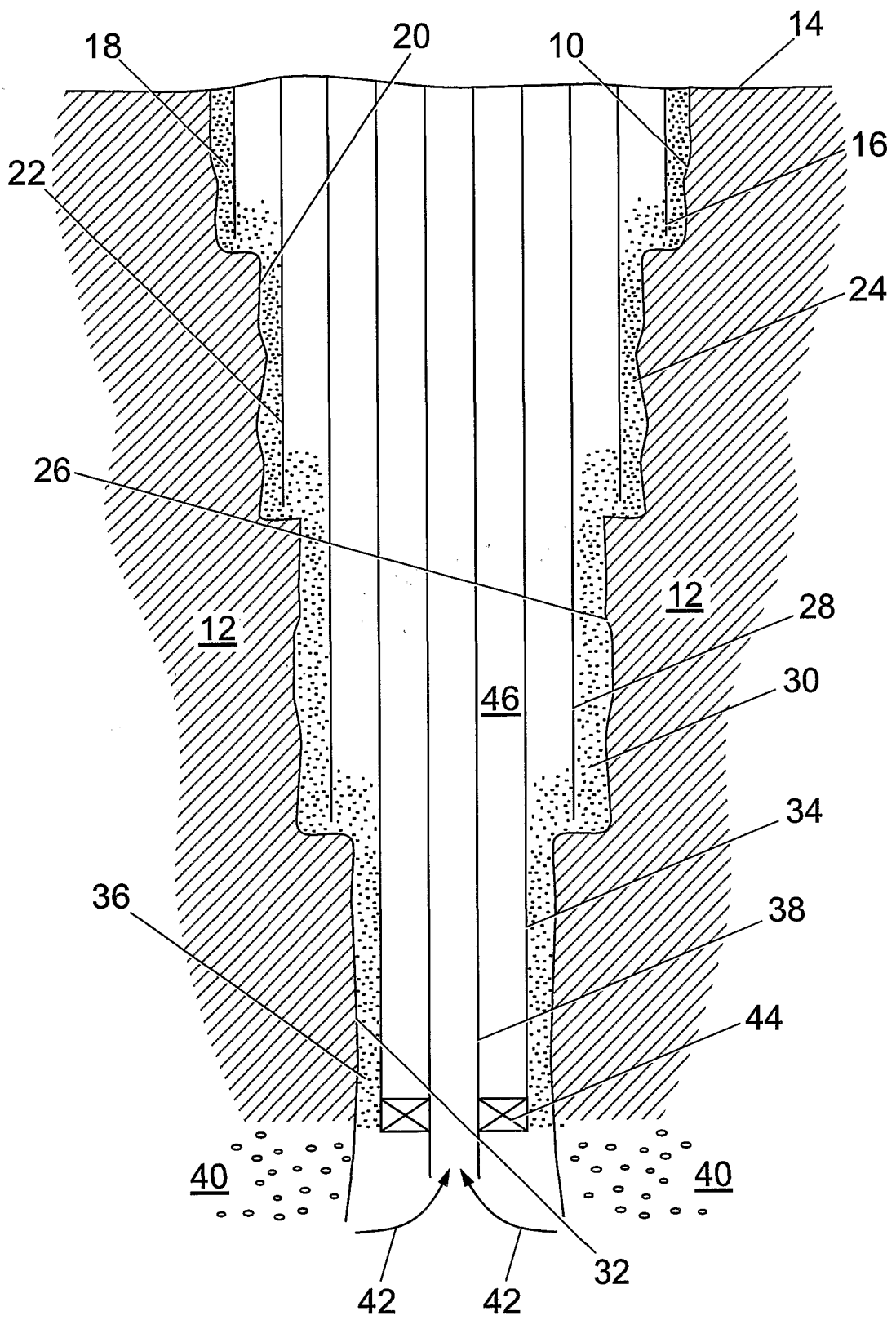

Fig. 1

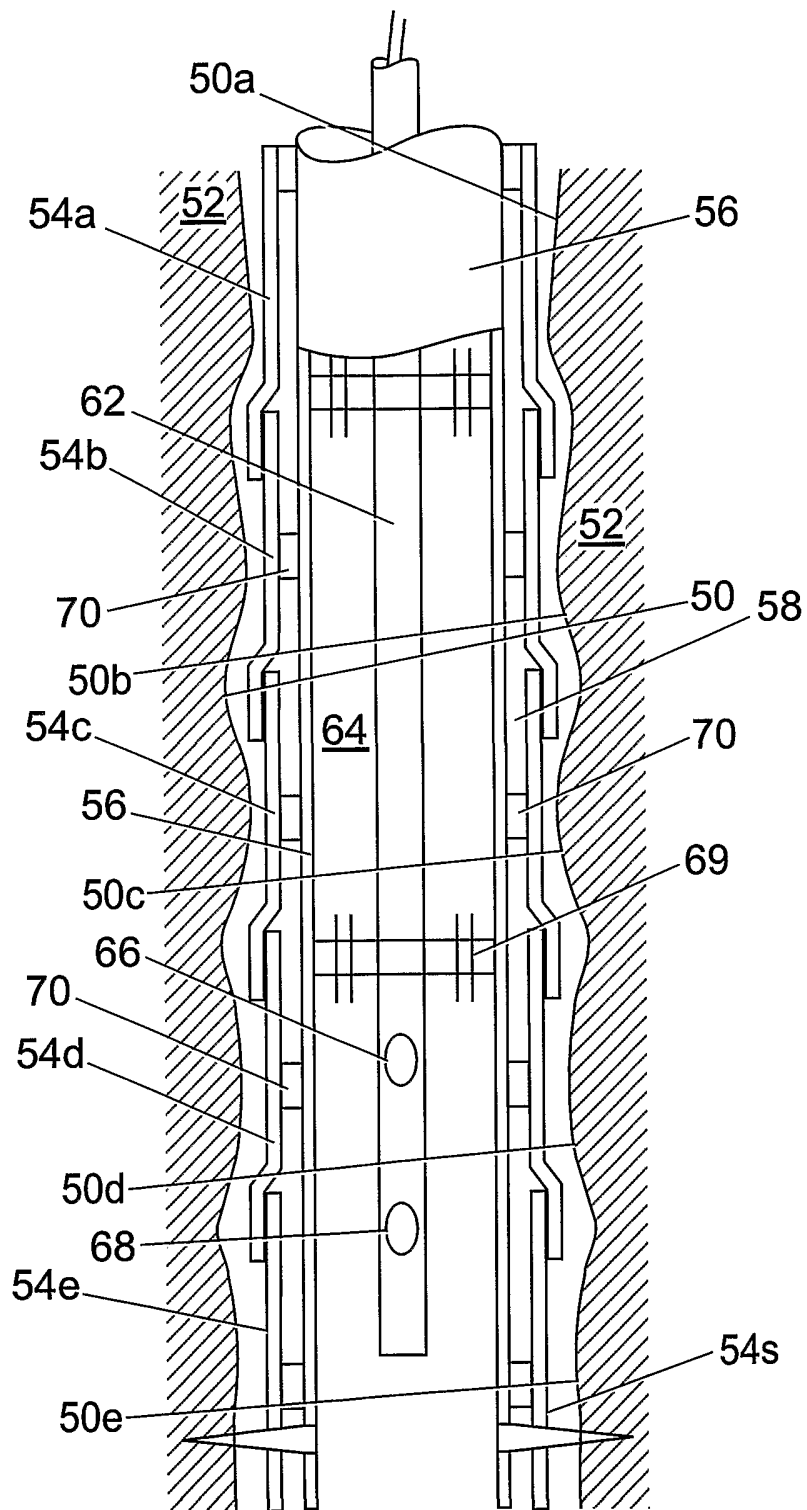
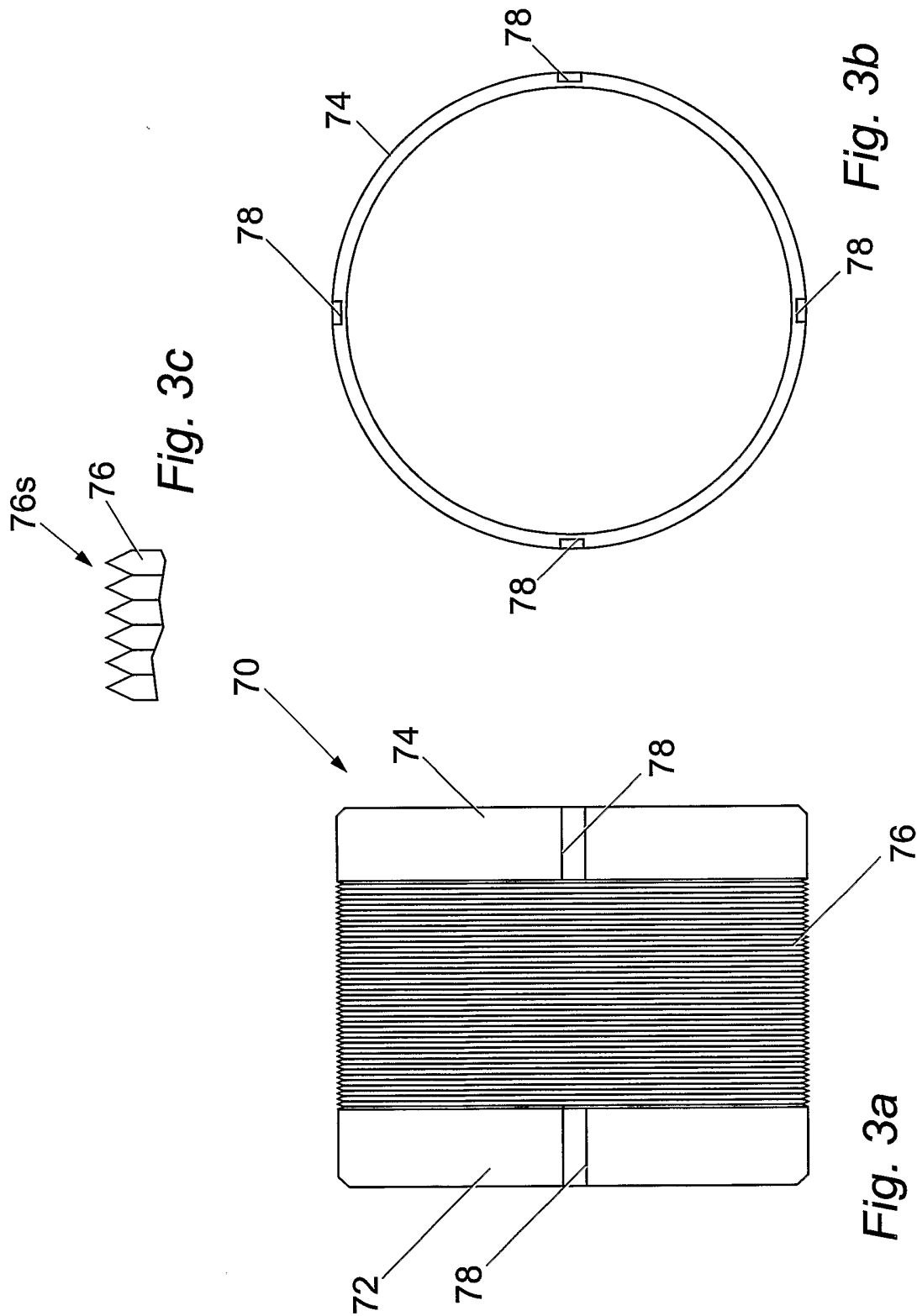

Fig. 2



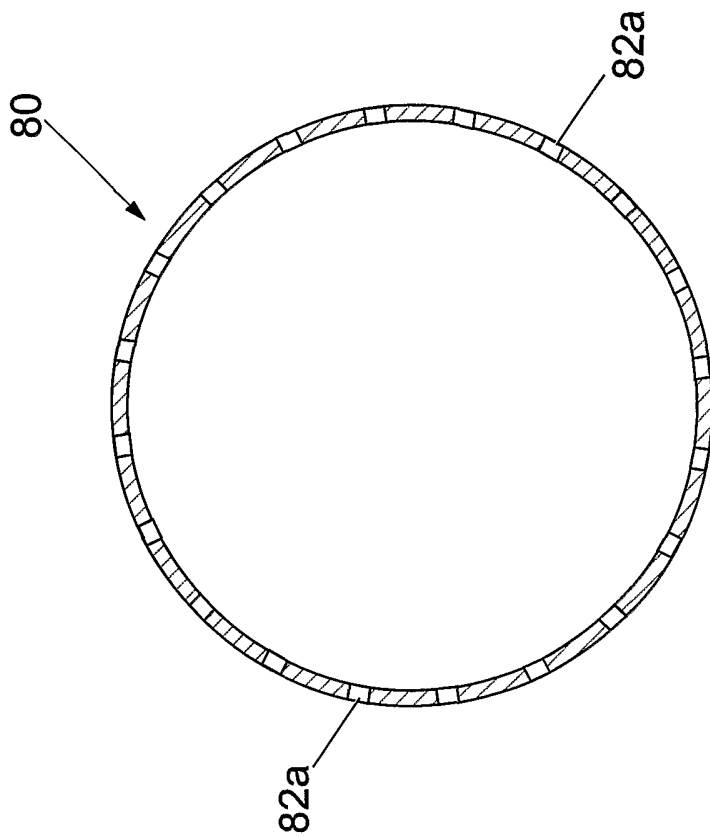

Fig. 4b

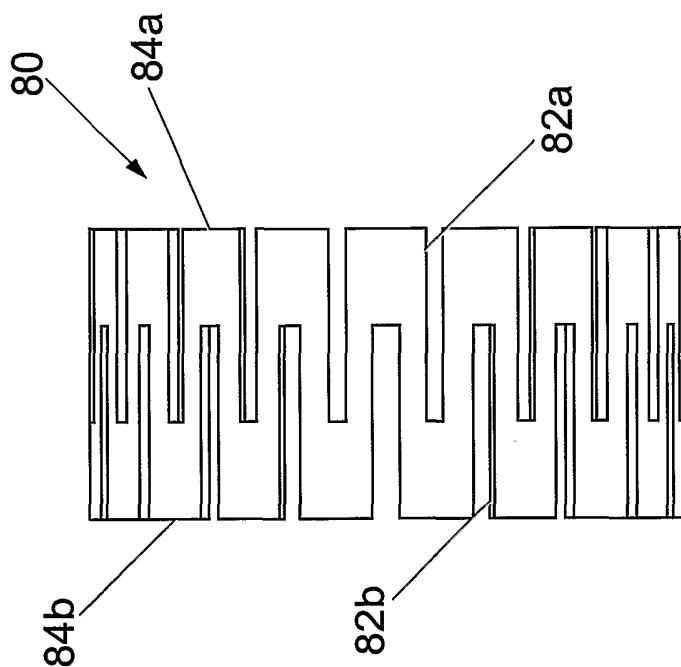

Fig. 4a