

(Model.)

2 Sheets—Sheet 1.

T. C. MERZ.
CAPSULE MACHINE.

No. 334,792.

Patented Jan. 26, 1886.

Fig. 1.

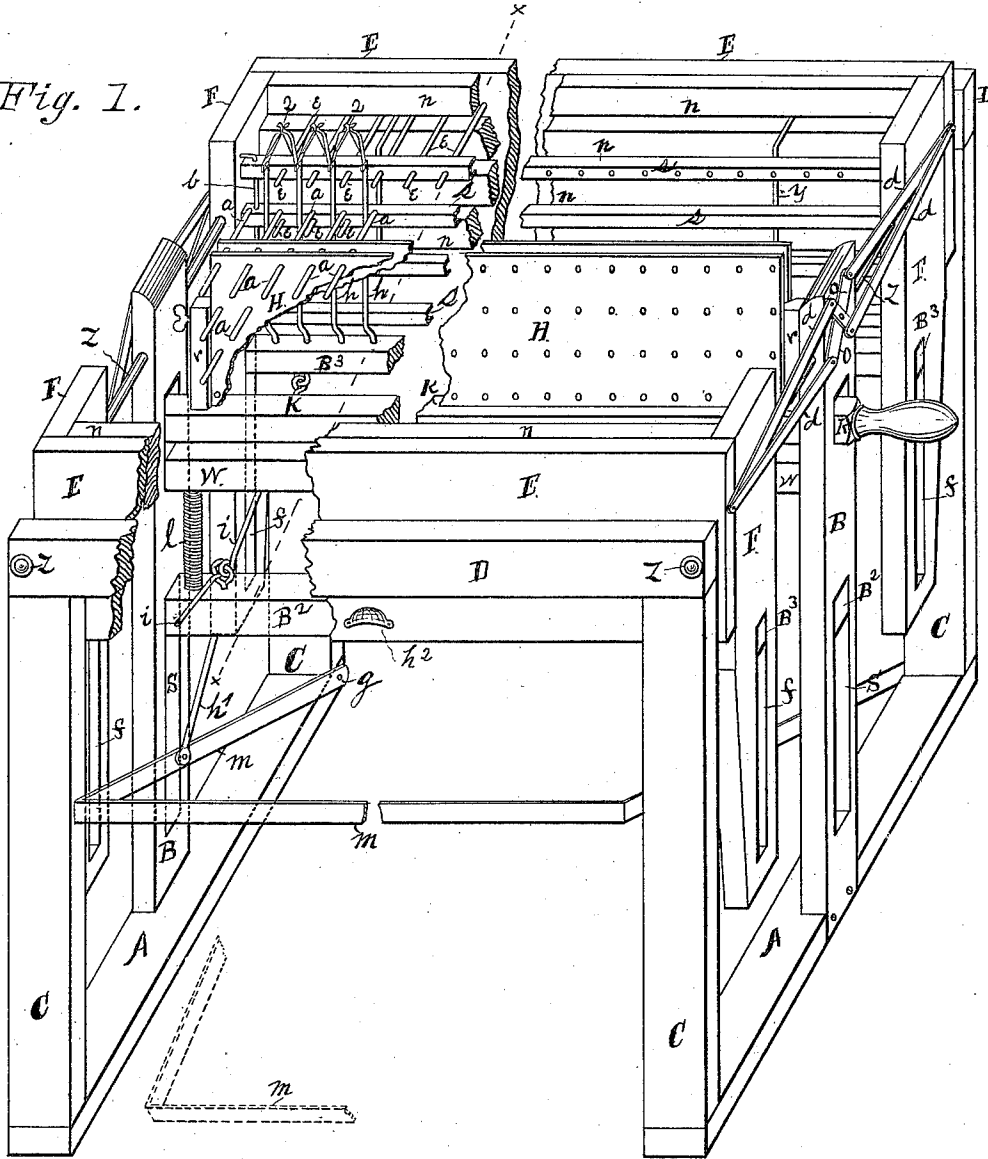

WITNESSES:

Ino G. Doyle
Wm B Doyle

INVENTOR:

Theodore C. Merz
By
Rasco B. Wheeler

UNITED STATES PATENT OFFICE.

THEODORE C. MERZ, OF DETROIT, MICHIGAN.

CAPSULE-MACHINE.

SPECIFICATION forming part of Letters Patent No. 334,792, dated January 26, 1886.

Application filed April 24, 1885. Serial No. 163,249. (Model.)

To all whom it may concern:

Be it known that I, THEODORE C. MERZ, a citizen of the United States, residing at Detroit, in the county of Wayne and State of Michigan, have invented certain new and useful Improvements in Devices for Removing Surplus from Capsule-Pins; and I do declare the following to be a full, clear, and exact description of the invention, such as will enable others skilled in the art to which it appertains to make and use the same, reference being had to the accompanying drawings, and to the letters and figures of reference marked thereon, which form a part of this specification.

My present invention consists in the means employed for removing, before dry or hardened, the surplus or trimmed portion of capsules from their pins after being separated from the part or parts forming the capsule. The mechanical parts of the sides of this machine are in duplicate, connected together so as to operate simultaneously upon a double faced capsule-pin plate, as hereinafter set forth.

Figure 1 is an isometrical view having parts separated or broken transversely to show connecting parts. Fig. 2 is an elevation, part in section, on dotted lines *x x* of Fig. 1. Fig. 3 is an enlarged perspective of the wipers and supporting-rods.

The frame supporting the works consists of the parts A B C D. Passing through the parts D B of the frame are supporting-rods L L. Upon said rods I mount freely the traveling parts E F. The sides E, sliding freely on said rods, are connected together by the pivoted folding bars *d o*. The bars *o* are pivoted to the uprights B, as shown in Fig. 1. The plate H, containing the capsule-pins *a* on both sides, is located in the center of the machine in an upright position, being supported by the bar K, and secured at the ends by uprights *r*. The inner faces of the sides E are provided with the pins *e*. The free ends of said pins project horizontally through the metal bars *s*, and said pins are located between the horizontal rails *n*. Said rails are attached to the uprights F. (See Figs. 1 and 2.)

Y represents bails anchored to the sides E, passing forward between the rails *n*, thence

vertically in front of said rails, as clearly shown in Fig. 2.

B² is a horizontal bar, its ends working freely within the slots S of the uprights B. I attach to said bar two depending rods, as *h'*, which are also attached to the operating-lever *m*. Said lever is pivoted to the frame, as shown at *g*.

B³ represents operating-bars parallel with the bar B², which are fitted at the ends to move freely within the openings *f* of the sliding uprights F. The bars B³ are connected near the ends to the bar B² by the pivoted rods *i*. The bar W affords a central support for the machine, and is firmly attached to the stationary uprights B. Below said bar near each end I locate the springs *l*, which lift the movable bar B². (See Figs. 1 and 2.)

Mounted upon the traveling bars B³ is a series of vertical rods, *h*, to the curved upper ends of which I attach the metal wiping-blades 2. Said blades are attached on opposite sides of said rods by rivets *v*, (see Fig. 3,) being spread apart at the top. The free end of each blade is bent back and over itself, forming the lip V'. Said blades are arranged upon the rods *h*, so that the curved free portion of the blade of one rod meets the curved free portion of the blade of the next rod of the series, thereby forming the V-shaped pockets *t*. (See Fig. 3.) I secure over the curved ends *v'* of the blades a flexible or cloth wiper, 4, which is attached to the body of each blade at *c*. (See Fig. 3.) The series of metal bars *s* is attached to the traveling uprights F, by means of the vertical rods *b*, passing through said bars and into the uprights, as shown in Figs. 1 and 2.

In the manufacture of capsules by machines of this class they are formed upon the pins *a* of the plate H by dipping in the usual way, which need not be described. As the capsules form upon the ends of said pins, they vary in length and are trimmed or cut to the desired length by suitable means while upon the pins, as indicated at 1, (see Fig. 2,) in which 5 represents the capsule and 8 the surplus or severed portion.

The plate H, containing the pins, with capsules, is placed in the center of the machine,

as shown in Fig. 1. The side of the machine on which is the handle h^2 is forced toward the capsule-plate. The opposite side of the machine is also simultaneously advanced by the connection through the folding bars d o . As the sides advance, the wiping-pins e are projected through and beyond the face of the bars s , the sides pressing against the series of rails n , attached to the traveling uprights F , causing said uprights to also advance, thereby moving forward the bars B^3 , carrying the series of vertical rods h between capsule-pins a , thereby moving the wiping-blades 2 in a line vertically over the surplus or cut-off portion 8 of the capsules; also, advancing the series of bars s horizontally between the free ends of the capsule-pins a , containing capsules 5. (See Fig. 2.) The pins e are projected under each capsule pin a , in a direct line with said pins, as shown clearly in Fig. 2. The lever m is then forced down to the dotted position of Fig. 1, drawing down the central supporting-bar, B^2 , also the operating-bars B^3 , by means of the coupling-rods i , as indicated by dotted lines in Fig. 2, thereby drawing down the series of wiping-blades 2, supported upon the vertical rods h of said bars. As the wiping-blades are drawn down, the cloth or flexible covering 4 is drawn across the surplus or severed portion 8 of the capsules upon the pins, and by the pressure of the spring-metal blades 2 said portion or portions are caused to break or separate from the pins, and as the wipers pass each capsule-pin they close, holding the removed portion 8 within the pockets t . As the wipers pass down from a capsule-pin, they are drawn over the free ends of the wiping-pins e , which removes the surplus from the pockets t , and (as the material is of an adhesive nature, being removed before hard or dry) it remains on the pins e . The wiping-blades 2 are forced down until they have passed alternately across the capsule and wiping-pins, as set forth. The lever m is kept depressed when the sides of the machine are drawn back by the handle h^2 and mechanism set forth. The side supports, E , move first, drawing the pins e back until the free ends are flush with the vertical face of the bars s , removing the surplus from said pins as they draw through the holes of said bars. The sides move back until the bails Y , attached thereto, strike the face of the series of bars n , (see Fig. 2,) when said bars, the uprights F , the operating-bars B^3 , and series of wipers 2 will be removed or receded from the capsule-pins a , when the plate H may be taken from the machine. The lever m is then released, when the springs l force the bars B^3 up to their former position, thereby elevating the wiping-blades to the position of

Fig. 1, ready to repeat the operation when another capsule-plate is inserted.

Having thus fully set forth my present invention, what I claim as new, and desire to secure by Letters Patent, is—

1. In a gelatine-capsule machine, the combination of the capsule-pin plate and its capsule-pin, the wiping-blades, the cloth or flexible wipers attached thereto, said blades mounted upon a suitable support, and mechanism for drawing the wipers transversely over the severed portion of a capsule upon its pin, as and for the purposes set forth.

2. In a gelatine-capsule machine, the combination, with the capsule-pin plate, its capsule-pin, and capsule mounted thereon, of a wiping-pin located below the capsule-pin, the wiping-blades, the cloth or flexible wipers attached thereto, the vertical rod supporting the wiping-blades, and means for drawing transversely the wipers over the severed portion of a capsule and the wiping-pin, for the purposes set forth.

3. In a gelatine-capsule machine, the combination, with a capsule-pin plate having a series of capsule-pins with capsules and severed portions thereon, a series of wiping-blades, and wipers mounted upon suitable supports, of a series of wiping-pins, and mechanism for advancing said wiping-pins under the capsule-pins, and means for simultaneously advancing therewith the series of wipers vertically over the severed portions of the capsules, as set forth.

4. In a gelatine-capsule machine, the combination, with the frame, the supporting-rods having the sides and sliding uprights mounted thereon, said sides joined together by the pivoted levers, as set forth, and the series of wiping-pins attached to the sides, said sides adapted to be advanced toward each other, thereby bringing a wiping-pin vertically below each capsule-pin, of a double-faced capsule-pin plate, substantially as set forth.

5. In a gelatine-capsule machine, as set forth, the combination of the sliding uprights supporting the operating-bars within the vertical openings f , the fixed bar W , attached to the uprights B , the bar B^2 , working in the openings S of the uprights B , said operating-bars attached together by the coupling-rods i , the springs l , the bars B^3 , supporting a series of vertical rods and wiping-blades, as set forth, the connecting-rods h' , and lever for moving the parts specified.

In testimony whereof I affix my signature in presence of two witnesses.

THEODORE C. MERZ.

Witnesses:

R. B. WHEELER,
JNO. G. DOYLE.