



- (51) International Patent Classification:
A43B 3/16 (2006.01)
- (21) International Application Number:
PCT/US2014/012054
- (22) International Filing Date:
17 January 2014 (17.01.2014)
- (25) Filing Language:
English
- (26) Publication Language:
English
- (30) Priority Data:
61/754,534 19 January 2013 (19.01.2013) US
- (72) Inventors; and
- (71) Applicants : FENG, Zhen, Zhou [US/US]; 3646 Bellagio CT, Santa Rosa, CA 95404 (US). BUCKLEY, Thomas, N. [US/AU]; 12656 Newell Highway, Narrabri, New South Wales 2390 (AU). FENG, Zhen-Yu [US/MY]; Unit 23-0-2, Bangsar Permai Condo, Jalal Tandok, 59100 Kuala Lumpur (MY).

BZ, CA, CH, CL, CN, CO, CR, CU, CZ, DE, DK, DM, DO, DZ, EC, EE, EG, ES, FI, GB, GD, GE, GH, GM, GT, HN, HR, HU, ID, IL, IN, IR, IS, JP, KE, KG, KN, KP, KR, KZ, LA, LC, LK, LR, LS, LT, LU, LY, MA, MD, ME, MG, MK, MN, MW, MX, MY, MZ, NA, NG, NI, NO, NZ, OM, PA, PE, PG, PH, PL, PT, QA, RO, RS, RU, RW, SA, SC, SD, SE, SG, SK, SL, SM, ST, SV, SY, TH, TJ, TM, TN, TR, TT, TZ, UA, UG, US, UZ, VC, VN, ZA, ZM, ZW.

- (84) Designated States (unless otherwise indicated, for every kind of regional protection available): ARIPO (BW, GH, GM, KE, LR, LS, MW, MZ, NA, RW, SD, SL, SZ, TZ, UG, ZM, ZW), Eurasian (AM, AZ, BY, KG, KZ, RU, TJ, TM), European (AL, AT, BE, BG, CH, CY, CZ, DE, DK, EE, ES, FI, FR, GB, GR, HR, HU, IE, IS, IT, LT, LU, LV, MC, MK, MT, NL, NO, PL, PT, RO, RS, SE, SI, SK, SM, TR), OAPI (BF, BJ, CF, CG, CI, CM, GA, GN, GQ, GW, KM, ML, MR, NE, SN, TD, TG).

Declarations under Rule 4.17:

- as to the identity of the inventor (Rule 4.17(i))
- as to applicant's entitlement to apply for and be granted a patent (Rule 4.17(ii))
- as to the applicant's entitlement to claim the priority of the earlier application (Rule 4.17(iii))

- (74) Agent: SHERMAN, Edward, S.; Suite 303, 3554 Round Barn Blvd., Santa Rosa, CA 94903 (US).

- (81) Designated States (unless otherwise indicated, for every kind of national protection available): AE, AG, AL, AM, AO, AT, AU, AZ, BA, BB, BG, BH, BN, BR, BW, BY,

[Continued on next page]

(54) Title: ALL WEATHER CYCLING SHOE COVER

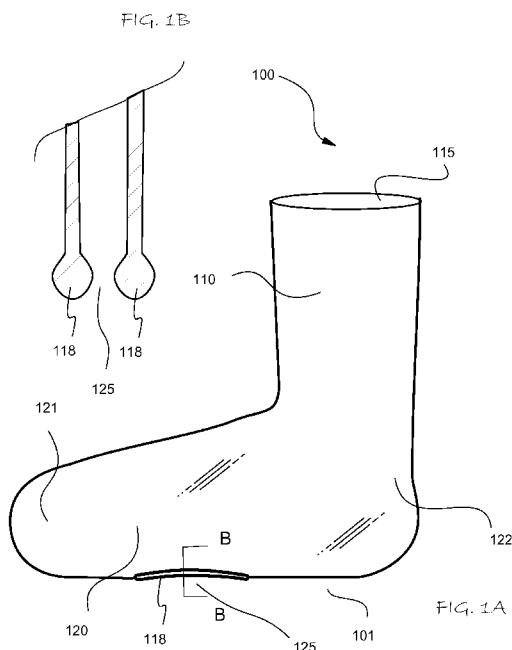

(57) Abstract: A cycling shoe cover is designed to provide maximum protection from the elements such as rain, snow, and cold. It also provides aerodynamic benefit with minimum weight. The cover is flexible unitary made from an elastomer, such as silicone or latex rubber, and is highly elastic and waterproof. The upper part of the cover fits snugly over the cyclist's ankle to prevent water egress into the shoes from above. The lower part of the cover snugly cover and seals to the bottom edge of the shoe without interfering with the cycling shoe's cleat or attachment to the cycle pedal.



— *of inventorship (Rule 4.17(iv))*

Published:

— *with international search report (Art. 21(3))*

— *before the expiration of the time limit for amending the claims and to be republished in the event of receipt of amendments (Rule 48.2(h))*

Specification for an International (PCT) Patent Application
for:

ALL WEATHER CYCLING SHOE COVER

Cross Reference to Related Applications

- 5 [0001] The present application claims the benefit of priority to the US Provisional patent application of the same title that was filed on Jan. 19, 2013, having application serial no. 61/754,534.

Background of Invention

- 10 [0002] The field of inventions is protective covers for shoes or footwear, and more particularly bicycle shoes such as those used in competitive bicycle racing and the practice thereof.

- 15 [0003] Currently most avid cyclists wear cycling shoes with cleats attached to the bottom of the shoes, which allow firm and secure contact with cycling pedals. Prior art shoe covers are intended to keep both the feet of the cyclist dry in inclement weather, or when splashes from puddles and mud may hit the cyclist. Such shoe covers protect portion of the shoe to some extent, but do not really keep the cyclist's feet dry. Further, such prior art or current cycling shoe covers are typically made from sheets of foamed and elastic fabric covered or filled "Neoprene" TM brand rubber or "Lycra" TM or "Spandex" brand fabric materials, which are heavy or can lose water resistance after
20 prolonged exposure to rain and snow. Most of these shoe covers are designed to slip over the shoe from below, a "bottom-up" installation process, and are secured with a zipper or Velcro TM brand hook and loop fasteners along a seam at the back or side of the foot and ankle. These covers are made by the
25 attachment of multiple precut fabric pieces, which creates multiples seams, allowing water to egress through the seams.

[0004] The third and most important weakness of the bottom-up design is that the seal around the ankle cannot be made sufficiently snug to prevent substantial water egress from above. The fourth weakness is that the bottom-up design is costly to produce, because of the materials, the attachment of multiple precut
5 pieces of these materials to each other, and the formation of these seams and, as well as the attachment of stays or fasteners.

[0005] Accordingly, it is an object of the invention to provide a new and improved cycling shoe cover that overcomes the above deficiencies of the prior art.

[0006] It is a further object to provide such a shoe cover a show cover that can be
10 made at significantly reduced costs.

[0007] The above and other objects, effects, features, and advantages of the present invention will become more apparent from the following description of the embodiments thereof taken in conjunction with the accompanying drawings

Summary of Invention

[0008] In the present invention, the first object is achieved by providing a tubular member formed of an elastic waterproof material, the tubular member comprising: a first tubular portion having an upper opening at the proximal end disposed orthogonal to a primary axis of thereof, and a distal end opposite the proximal end, and a second tubular portion closed at the distal end and connected in sealed unitary engagement at the proximal end in an orthogonal orientation to the distal end of the first tubular portion, and having a first generally elliptical opening on a lower portion thereof that is opposite the opening in the first tubular member.

[0009] A second aspect of the invention is characterized in by a die for forming a sock like protective cover, the die comprising a first generally planar portion having a foot like shape with rounded edges and a second portion extending downward from the rounded edge of the sole portion of the first generally planar portion.

[0010] Another aspect of the invention is characterized in by a method of forming a unitary elastic waterproof sock like protective cover, the method comprising the steps of providing the above die, coating the die with an elastomer forming liquid, solidifying the elastomer forming liquid on the die to replicate the shape of the die, removing the solidified form from the die, slitting the solidified form at an intermediate position on the second downward extending portion to leave a residual sleeve below a sole shaped lower portion of the sock like protective cover, rolling the residual sleeve upward on itself to form a thick continuous annular bead about the perimeter of the opening in the sole shaped lower portion of the sock like protective cover, wherein the rolled bead adheres to itself.

[0011] Another aspect of the invention is achieved by providing a unitary sock like tubular waterproof elastic member comprising an upper foot receiving portion

on an upper surface thereof having a shape adopted to receive an ankle and heel of a person, and a lower sole portion at the bottom of the upper foot receiving portion having at least one generally elliptical hole formed therein.

5 [0012] Another aspect of the invention is characterized by providing a second generally elliptical opening on the lower sole portion or second tubular portion thereof.

10 [0013] Another aspect of the invention is characterized by the elastic waterproof material that forms the tubular member material has a greater thickness along the perimeter of the first and/or second generally elliptical opening that on the portions distal therefrom.

[0014] Another aspect of the invention is characterized by the perimeter of the first and/or second generally elliptical opening that on the portions distal therefrom being an annular bead with a circular cross-section having a thickness of about 2-4 mm.

15 [0015] Another aspect of the invention is characterized by the elastic waterproof material being capable of stretching at least about 25%.

[0016] The above and other objects, effects, features, and advantages of the present invention will become more apparent from the following description of the embodiments thereof taken in conjunction with the accompanying drawings.

20

Brief Description of Drawings

- [0017] FIG. 1A is a top plan view of a first embodiment of the inventive shoe cover disposed on a flat surface, whereas FIG. 1B is a cross-sectional elevation of the portion indicated by section line B-B in FIG. 1A.
- 5 [0018] FIG. 2 is a perspective view showing the shoe cover of FIG. 1 installed over a cycling shoe, with the extent of the shoe cover illustrated by a mesh pattern.
- [0019] FIG. 3A is a side elevation view of a mold used to form the shoe cover of FIG. 1 and 2, whereas FIG. 3B is a front elevation view thereof and FIG. 3C is a cross-sectional elevation at section line C-C in FIG. 3A.
- 10 [0020] FIG. 4 is a top plan view of another embodiment of the inventive shoe cover disposed on a flat surface.
- [0021] FIG. 5 is a perspective view showing the shoe cover of FIG. 4 installed over a cycling shoe, with the extent of the shoe cover illustrated by a mesh pattern.
- [0022] FIG. 6A is a side elevation view of a mold used to form the shoe cover of
15 FIG. 4 and 5, whereas FIG. 6B is a front elevation view thereof and FIG. 6C is a cross-sectional elevation at section line C-C in FIG. 6A.
- [0023] FIG. 7 is a top plan view of another embodiment of the inventive shoe cover disposed on a flat surface.
- [0024] FIG. 8 is a perspective view showing the shoe cover of FIG. 7 installed over a
20 cycling shoe, with the extent of the shoe cover illustrated by a mesh pattern.
- [0025] FIG. 9A is a top plan view of another embodiment of the inventive shoe cover disposed on a flat surface, whereas FIG. 9B is an enlarged cross-sectional elevation of the highlighted region in FIG. 9A.

[0026] FIG. 10A is a side elevation view of a mold used to form the shoe cover of FIG. 8 and 9, whereas FIG. 10B is a front elevation view thereof and FIG. 10C is a cross-sectional elevation at section line C-C in FIG. 10A.

5 [0027] FIG. 11A is a side elevation view of a mold used to form the shoe cover of FIG. 12-17, whereas FIG. 11B is a front elevation view thereof and FIG. 11C is a cross-sectional elevation at section line C-C in FIG. 11A.

[0028] FIG. 12, 13, 14 and 15 illustrate consecutive steps of a user installing the shoe cover constructed using the mold illustrated in FIG. 11A-C, with the extent of the shoe cover illustrated by a mesh pattern.

10 [0029] FIG. 16 is a first perspective view of the installed shoe cover constructed using the mold illustrated in FIG. 11A-C, with the extent of the shoe cover illustrated by a mesh pattern.

[0030] FIG. 17 is a first perspective view of the installed shoe cover constructed using the mold illustrated in FIG. 11A-C, with the extent of the shoe cover
15 illustrated by a mesh pattern.

Detailed Description

[0031] Referring to FIGS. 1 through 17, wherein like reference numerals refer to like components in the various views, there is illustrated therein a new and improved All Weather Cycling Shoe Cover, generally denominated 100
5 herein.

[0032] In accordance with the present invention, the All Weather Cycling Shoe Cover is a generally sock shaped elastic member 100 for protecting the shoe and foot of a cyclist from exposure to cold temperature, water, snow, mud and road debris. It is formed as a unitary thin elastic member from a waterproof
10 material, such as natural rubber, natural rubber blends, latex rubber, synthetic rubber, polyisoprene, polychloroprene rubber ("Neoprene"™), nitrile rubber, butyl rubber, silicone rubber, polyvinyl chloride, polyurethane, and the like.

[0033] In one embodiment of the invention, the sock like member 100 has a generally tubular shape when opened and elastically expanded by a shoe or foot and ankle that are wider than the sock like member 100. The sock like shape of show cover 100 is generally formed by a first generally cylindrically shaped tube member 110 having an opening 115 at the proximal end that is disposed orthogonal to a primary axis of the first cylindrical tube member 110, and a second tubular member 120 is closed at the distal end 121 (for receiving the
15 toe end of a shoe) connected in sealed engagement at the proximal end to the distal end of the first cylindrical member 110. first generally cylindrically shaped tube member 110 designed to snugly fit around the cyclist's upper ankle. The second tubular portion is sloped downward from the intersection with the first cylindrical member to snugly accommodate a shoe. The second tubular member 120 has at least one generally elliptical opening 125 around a
20 lower or outer side portion thereof, which is on the opposing side of the shoe cover 101 from the first opening 115. The generally elliptical opening 115 is disposed on the outer side 101 of the second cylindrical member closer to the closed distal end 121 than the end connected to tubular member 110. When a
25

first embodiment of the shoe cover 100 is installed as shown in FIG. 2,5, the aperture or opening 125 in FIG. 2 accommodates the cleat 16 that extends downward from near the toe of shoe, while the heel piece 17 is optionally covered by the lower surface of shoe cover 100.

5 [0034] As the shoe cover 100 is intended to stretch over the user's shoe 15 to provide a tight seal, the sock like member 100 need not have a full 3-dimensional pseudo or anatomical foot or shoe shape. Hence, the reference to the parts of the cover having a generally cylindrical or tubular shape should not be considered limiting, but merely to exemplary, as alternative shapes in
10 the generally form of a foot, but smaller than the intended users foot and shoe dimensions, will provide similar benefits

[0035] In a second embodiment of the invention shown in FIG. 4, the sock like member 100 includes a second generally elliptical opening 126 disposed on the bottom between the proximal end 122 of the second tubular member and a
15 first generally elliptical opening 115. The aperture or opening 125 in FIG. 5 accommodate the cleat 16 that extends downward from the heel of the shoe, while the heel piece 17 extends through the second opening 126, shown in FIG. 5.

[0036] FIG. 3A-3B illustrates the process of forming the shoe cover sock like
20 member using a generally planar sock shaped die 300. The dimensions shown in FIG. 3A are in mm and are intended to be merely exemplary, and non-limiting. The face 310 of the die 300 is preferably flat, with all edges 311 rounded, preferably at a radius that is half the thickness of the die forming plate, which is preferably about ¼ inch (about 6-7 mm). The bottom of the die
25 300 that would correspond to the placement of the first elliptical opening has a protuberance or extension 330 in along an axis that is parallel to the cylindrical axis of what will become the first cylindrical tube member 110, but extending in the opposite direction. The die 300 is held by this protuberance 330, as for example via the holes shown therein when dipped in an elastomer

forming liquid, such as for example a concentrated solution or either latex or other elastic polymers, or a monomer, pre-polymer or other oligomeric liquid or mixture. A thin liquid coating will remain on die 300 upon removal and draining of excess liquid. Then, upon solidification of this liquid coating, such as upon drying to remove solvent, or alternatively the curing and cross-linking of the monomer, pre-polymer or other oligomer in the elastomer forming liquid, a thin elastic coating is formed on the die 300 having the general shape of a sock 100. It should be appreciated that the same die shape can be deployed when the liquid elastomer forming fluid is applied to the surface thereof by spray coating, curtain coating and the like.

[0037] After application and curing or otherwise sufficient solidification of the liquid elastomer forming compound on the outer surface of the die 300, the sock 100 is slit at positions 340 and optionally 350 to create a thicker perimeter around the generally elliptical openings 125 and 126. The portion 355 between slit position 350 and the intended bottom 101 of the sock 100 is rolled over itself to form the thicker edge or band 118 at the perimeter of the first elliptical opening 125 defined by protuberance 330. Slitting can occur after removal from die 330. However, in a more preferred embodiment of the invention, the perimeter 118 of each generally elliptical opening 125 and 126 is considerably thicker than the elastic material that forms the body of the sock like member 100. When the sock like shoe cover 100 is formed of latex rubber, the thickness over the surface thereof distal from the opening is preferably about 0.2 mm to about 0.4mm, with the thicker edge or band 118 at the elliptical and/or upper opening preferably having a circular cross-section with a diameter of about 3 mm to about 5 mm, and more preferably about 4 mm. Preferably, heat is used to further cure the latex, and the slitting is carried out while the latex is hot to enable self adhesion and/or residual curing to complete the reactions necessary to form a strong and coherent thicker edge 118 upon roller the portion between slit position 355 and the bottom 101.

[0038] In the embodiment shown in FIG. 6, the die 300 has a first and second protuberance 330 and 332 to form the generally elliptical hole or slit 125 and 126 respectively of the shoe cover shown in FIG. 4 and 5. Edge 118 is similarly formed by rolling portion 365 formed on the second die protuberance 332. It should be understood that either or both of holes 125 and 126 can optionally be circular and need not have a perfect elliptical shape, as the term elliptical is used to generally embrace rectangular holes rounded corners or a slit with rounded sides. However, to the extent that the intended hole or slit 126 is not intended to stretch significantly on opening, the opening 126 may be formed without the use of protuberance 332, deploying for example die 300 of FIG. 3, and slitting the lower bottom surface 101 after molding.

[0039] In FIG. 7, the shoe cover 100 is formed by slitting the freshly cast preform after removal from the die 300 at reference line 340' (FIG. 6), generally removing a significant portion of the first cylindrical tube member 110 and placing the upper opening 116 at an acute angle across the primary axis of the second tube member 120. Fig. 8 illustrates the expanded cover 100 of FIG. 7 installed to cover the shoe 15 of the user 10, in which sock 13 is now exposed both above the shoe 15 and the shoe cover 100. The embodiment of FIG.7 can be installed over the shoe after the user is wearing the shoe.

[0040] In a more preferred embodiment of the invention, illustrated with the aid of FIG. 9A, 9B and FIG. 10, the die 300 in FIG. 10 has a series of 2 or more spaced apart and indented annular channels 360 and 361 around what will become the first cylindrical portion 110 of the sock 100. As the channels 360 and 361 will tend to retain more elastomer forming liquid compound on coating the die 300, due to surface tension, upon extraction from die 300 filled annular channels will replicate into a pair of spaced apart annular bands or flange 160 and 161 on the corresponding portion of the sock like shoe cover member 100 as shown in the embodiment in FIG. 9A and 9B. Then, upon installation on the ankle 11 of the user 10, these bands 160 and 161, will form

a tighter sealing surface by concentrating a compressive stress in a narrow region on the user's leg/ankle 11 or sock 13 to further preclude water egress in harsher conditions. As shown in FIG. 9A and 9B, these bands 161 and 162 preferably have a height (H) of about 2- 4 mm and a depth (D) of about 1.0 to about 1.5 mm. They are also preferably separated from each other by about 5 to 20 mm, and more preferably by about 10 mm, and are also preferably disposed about 5 to 20 mm, but more preferably about 10 mm, from the top of the sock like shoe cover 100.

5

10

[0041] In FIG. 11A-C, the die 300 has a single large protrusion 330 that is intended to form a lower generally elliptical opening 125 in the bottom of the sock shown in FIG. 12-17.

15

20

[0042] It should now be appreciated that the sock like shoe cover of the various embodiments, is preferably placed on the ankle to form a water tight seal before or after socks are worn. Thus, as shown in FIG. 12 the cyclist 10 first places the shoe cover 100 over the ankle 11, then puts on the socks 13 (FIG. 13) and cycling shoe 15 on in FIG. 14, and finally in FIG. 15 pulls the shoe cover over the shoe 15 from above. The shoe cover 100 is flipped over the shoe and cradles the edge of the sole by about 1 cm all around to provide a secure fit. Because the shoe cover 100 will not be in contact with the cleat 16, it will not interfere with the engagement of the cleat 16 and pedal of a bicycle. The aperture or opening 125 in FIG. 17 accommodate both the cleat 16, and the heel piece 17.

25

[0043] It should now be appreciated that the inventive shoe cover 100 uniquely and inventively departs from prior art design by enabling a "top-down" installation, which covers the entire shoe from above with a single piece of material. This ensures a tight seal around the ankle and the entire upper surface of the shoe, providing maximum water, snow, and wind resistance.

[0044] It should be understood that the shoe cover 100 is intended to stretch at least about 20 to 30% of the original length to form a snug fit at the user's 10 ankle

or calf 11. However, the elastomer forming the shoe cover 100 should also be about to stretch without tearing, undergoing permanent deformation or strain hardening when stretched by at least about 40% to about 80 %, and preferably at least 60% to fit over the shoe and retain a tight seal at the ankle 11 by
5 remaining stretched to about 15 to 30%, and more preferably at least about 20%, on the user's calf and ankle above the shoe 15. However, the shoe cover 100 is also preferably sized so that once installed on the shoe it has preferably stretched at least about 20 to 30% at each hole or aperture in the sole portion and to both reduce water egress into the shoe from above and slippage of the
10 cover during cycling.

[0045] For example, a well fitted shoe cover 100 will stretch about 60% at the portion that extends over the toe, and 80% to extend over the heel. Then upon fitting over the shoe 15, the elastic material while relaxing is still stretched preferably about 20 to 30% at the apertures 125 or 126 on the bottom or sole
15 portion 101.

[0046] If the shoe cover 100 needs to be removed from the shoe while the cleat is engaged with the pedal, the cyclist can simply tear the cover off and discard it. Whereas discarding a "bottom-up" shoe cover would be prohibitively expensive, discarding the "top-down" shoe cover (the present invention)
20 would be economically feasible because the cover is made of a single-mold piece of inexpensive elastomer, such as latex rubber. In contrast, with the "bottom-up" shoe cover, the cyclist has to disengage the pedal from the cleat in order to remove the cover, which can be dangerous.

[0047] While the invention has been described in connection with a preferred
25 embodiment, it is not intended to limit the scope of the invention to the particular form set forth, but on the contrary, it is intended to cover such alternatives, modifications, and equivalents as may be within the spirit and scope of the invention as defined by the appended claims.

Claims

[c1] A tubular member formed of an elastic waterproof material, the tubular member comprising:

- 5 a) first tubular portion having an upper opening at the proximal end disposed orthogonal to a primary axis of thereof, and a distal end opposite the proximal end,
- b) second tubular portion closed at the distal end and connected in sealed unitary engagement at the proximal end in an orthogonal orientation to the distal end of the first tubular portion, and having a first generally elliptical opening on a lower portion thereof that is opposite the opening in the first tubular member.
- 10

[c2] The tubular member according to claim 1 and further comprising a second generally elliptical opening on the lower portion thereof that is opposite the upper opening in the first tubular member.

[c3] The tubular member according to claim 1 wherein the elastic waterproof material that forms the tubular member material has a greater thickness along the perimeter of the first generally elliptical opening than on the portions distal therefrom.

15

[c4] The tubular member according to claim 3 wherein the portion of greater thickness along the perimeter of the first generally elliptical opening is a continuous bead with a generally circular cross-section.

[c5] The tubular member according to claim 4 wherein the elastic materials is a latex containing rubber with a thickness of between about 0.2 to 0.4 mm and the bead along the perimeter of the first generally elliptical opening has a diameter of at least about 4 mm.

20

[c6] The tubular member according to claim 2 wherein the elastic waterproof material that forms the tubular member material has a greater thickness along the perimeter of the first and second generally elliptical openings than on the portions distal therefrom

5 [c7] The tubular member according to claim 6 wherein the portion of greater thickness along the perimeter of the first and second generally elliptical opening is a continuous bead with a generally circular cross-section.

[c8] The tubular member according to claim 6 wherein the portion of greater thickness along the perimeter of the first and second generally elliptical openings is a
10 continuous bead with a generally circular cross-section.

[c9] The tubular member according to claim 7 wherein the elastic materials is a latex containing rubber with a thickness of between about 0.2 to 0.4 mm and the bead at the first and second generally elliptical opening has a diameter of about 2 mm.

15 [c10] The tubular member according to claim 1 wherein the first tubular portion has one or more interior annular beads on the inner surface thereof disposed below the upper opening at the proximal end thereof that is generally disposed orthogonal to the primary axis thereof.

[c11] The tubular member according to claim 10 wherein the one or more interior annular beads has a thickness of at least about 1.0 mm.

20 [c12] The tubular member according to claim 11 wherein the one or more interior annular beads has a height of at least about 2 mm.

[c13] The tubular member according to claim 1 wherein the elastomer is latex rubber having a thickness of about 0.2 to 0.4 mm.

25 [c14] The tubular member according to claim 1 wherein the portion of the elastomer proximal to the lower generally elliptical opening is capable of stretching at least about 40%.

[c15] A die for forming a sock like protective cover, the die comprising:

a) a first generally planar portion having a foot like shape with rounded edges,

b) a second portion extending downward from the rounded edge of the sole portion of the first generally planar portion.

5

[c16] The die for forming a sock like protective cover according to claim 11 further comprising a third portion extending downward from the rounded edge of the sole portion of the first generally planar portion.

[c17] A method of forming a elastic waterproof sock like protective cover, the method comprising the steps of :

- a) providing the die of claim 15,
- b) coating the die with an elastomer forming liquid,
- 5 c) solidifying the elastomer forming liquid on the die to replicate the shape of the die,
- d) removing the solidified form from the die,
- e) slitting the solidified form at an intermediate position on the second downward extending portion to leave a residual sleeve below a sole shaped lower portion of
10 the sock like protective cover,
- f) rolling the residual sleeve upward on itself to form a thick continuous annular bead about the perimeter of the opening in the sole shaped lower portion of the sock like protective cover, wherein the rolled bead adheres to itself.

[c18] The method of forming an elastic waterproof sock like protective cover
15 according to claim 17 wherein said step of slitting the solidified form at an intermediate position on the second downward extending portion to leave a residual sleeve below the sole shaped portion sock line cover occurs before the solidified form is removed from the die.

[c19] The method of forming an elastic waterproof sock like protective cover
20 according to claim 17 further comprising the step of slitting the solidified form on the first generally planar portion of the die to form a foot receiving opening in the sock like protective cover.

[c20] The method of forming an elastic waterproof sock like protective cover
25 according to claim 17 wherein solidified elastic materials is capable of stretching to at least about 20% and the rolled bead has a diameter of about 2 mm.

[c21] A sock like unitary tubular waterproof elastic member comprising:

a) an upper foot receiving portion on an upper surface thereof having a shape adopted to receive an ankle and heel of a person,

5 b) a lower sole portion at the bottom of the upper foot receiving portion having at least one generally elliptical hole formed therein.

[c22] The sock like unitary tubular waterproof elastic member according to claim 21 and further comprising a second generally elliptical opening on the lower sole portion thereof.

10 [c23] The sock like unitary tubular waterproof elastic member according to claim 21 wherein the elastic waterproof material that forms the tubular member material has a greater thickness along the perimeter of the first generally elliptical opening than on the portions distal therefrom.

15 [c24] The sock like unitary tubular waterproof elastic member according to claim 23 wherein the portion of greater thickness along the perimeter of the first generally elliptical opening is a continuous bead with a generally circular cross-section.

20 [c25] The sock like unitary tubular waterproof elastic member according to claim 24 wherein the elastic materials is a latex containing rubber with a thickness of between about 0.2 to 0.4 mm and the bead along the perimeter of the first generally elliptical opening has a diameter of at least about 2 mm.

FIG. 1B

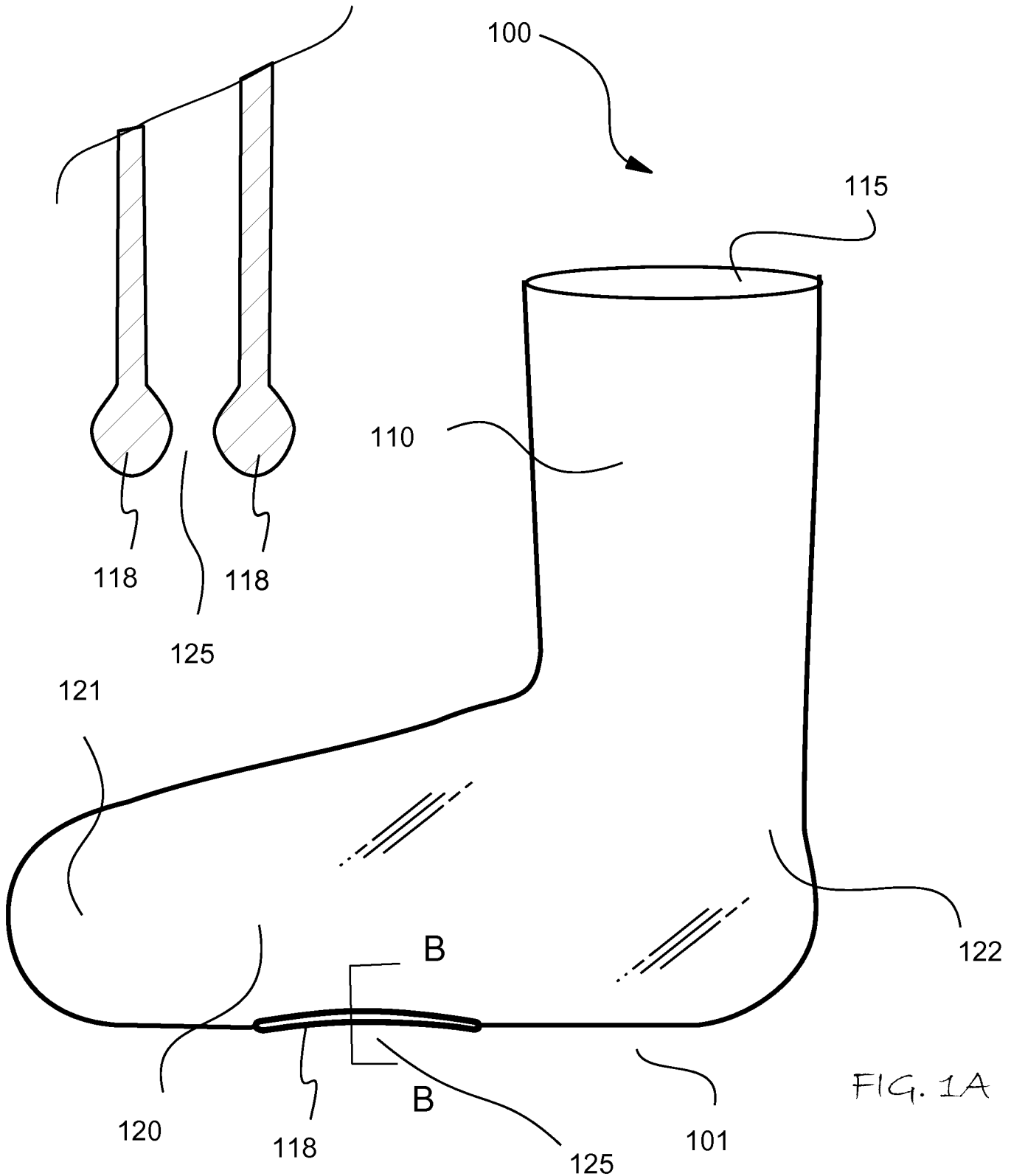

FIG. 1A

FIG. 2

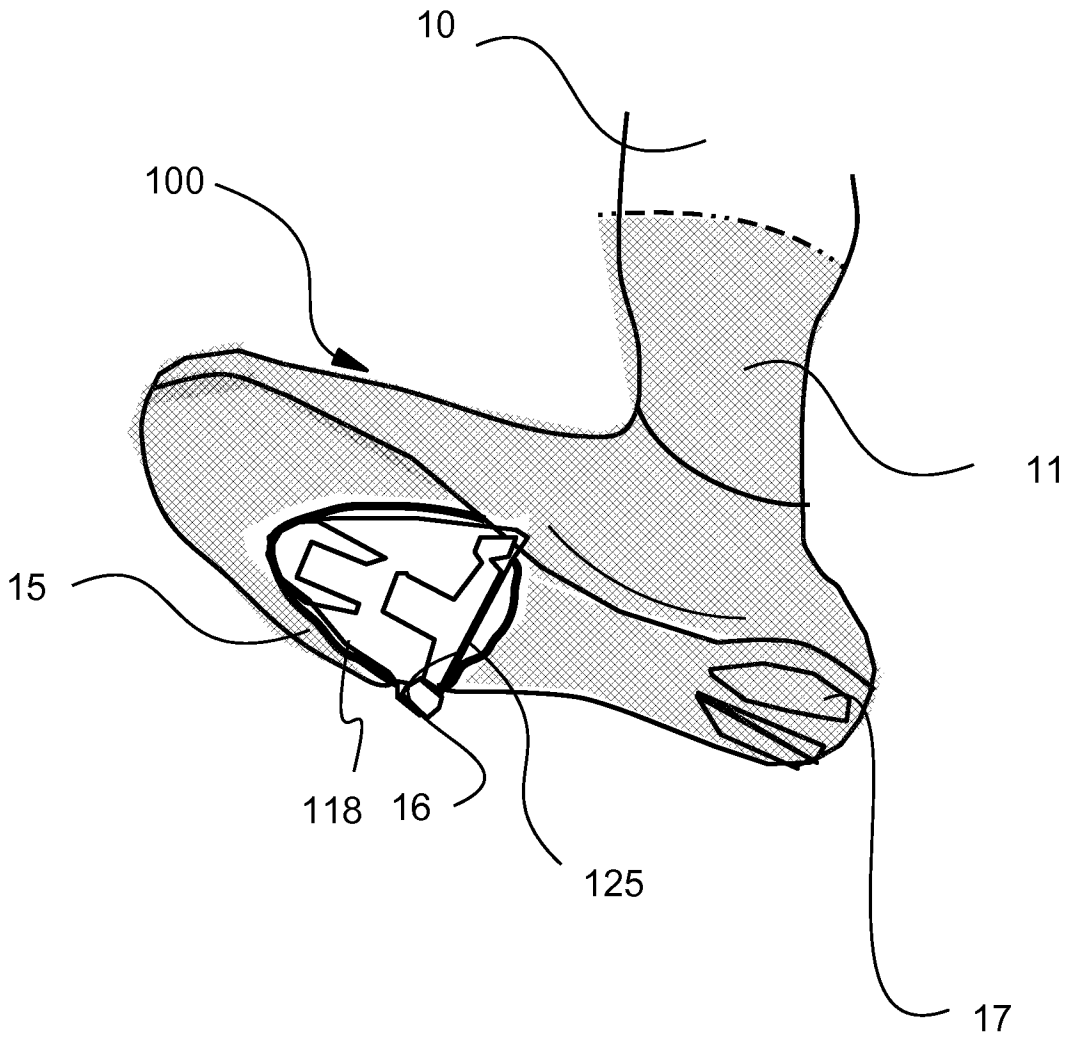

FIG. 3C

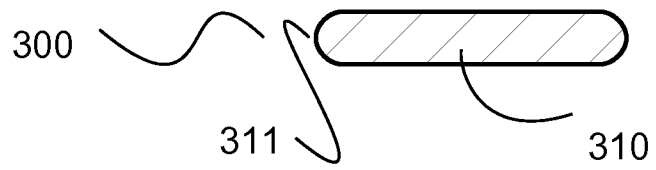
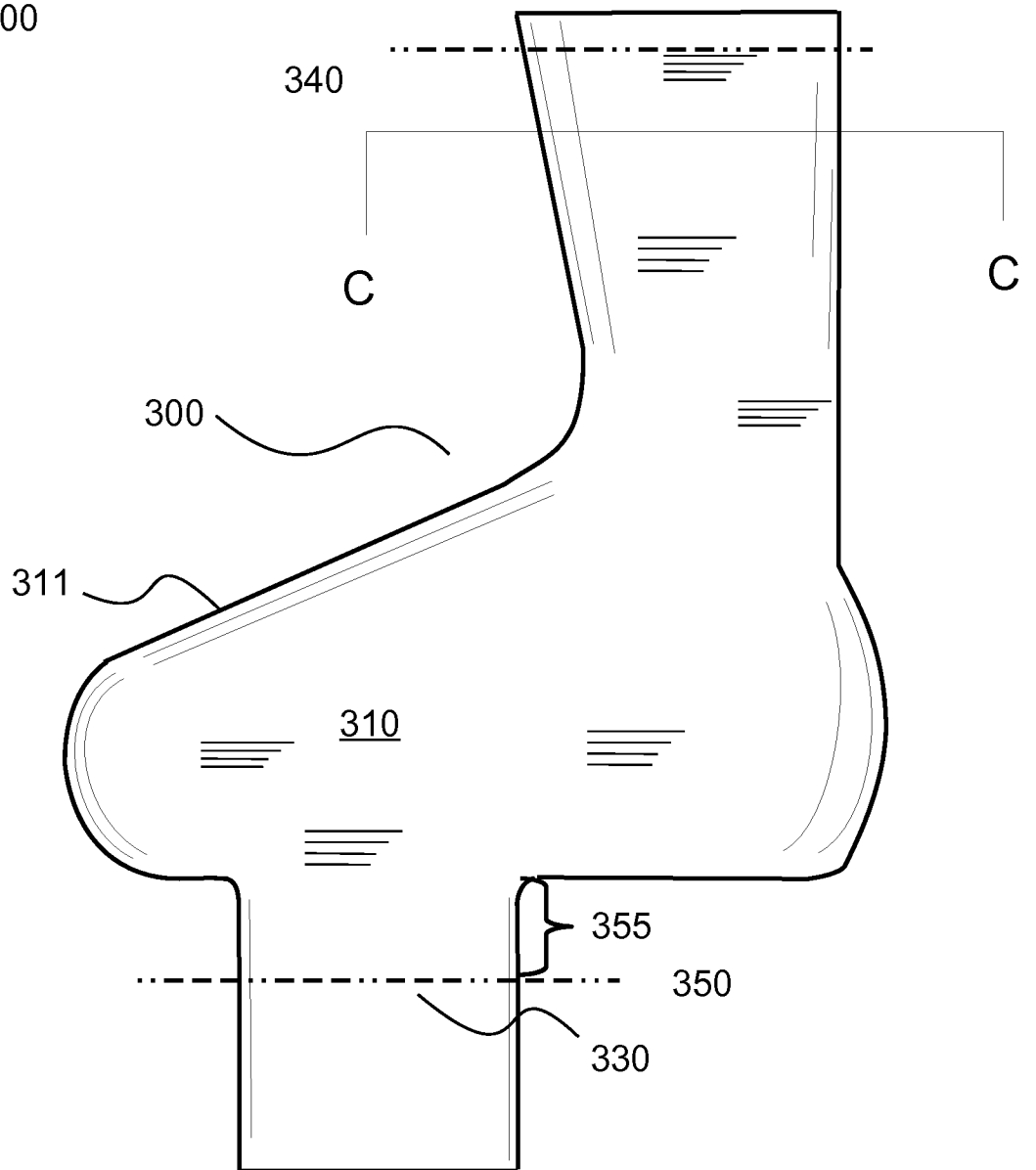
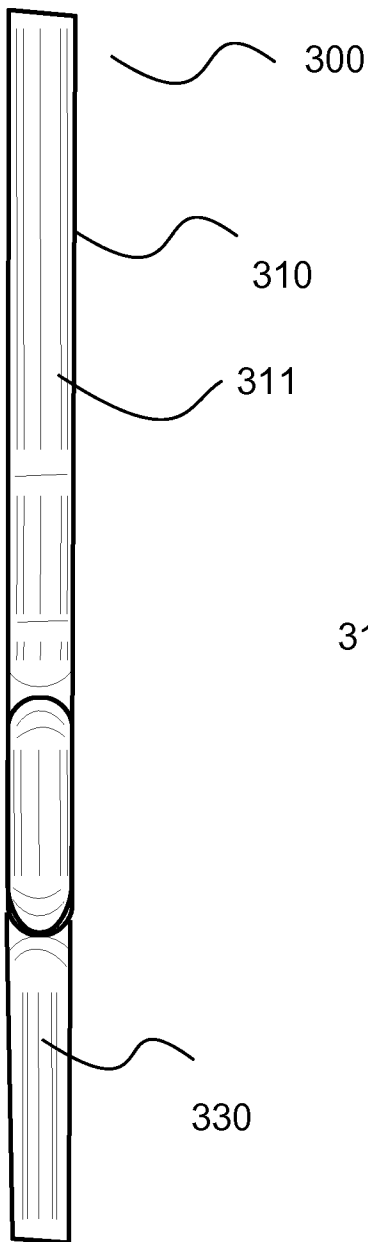

FIG. 3B



Dimensions in mm

FIG. 3A

FIG. 4

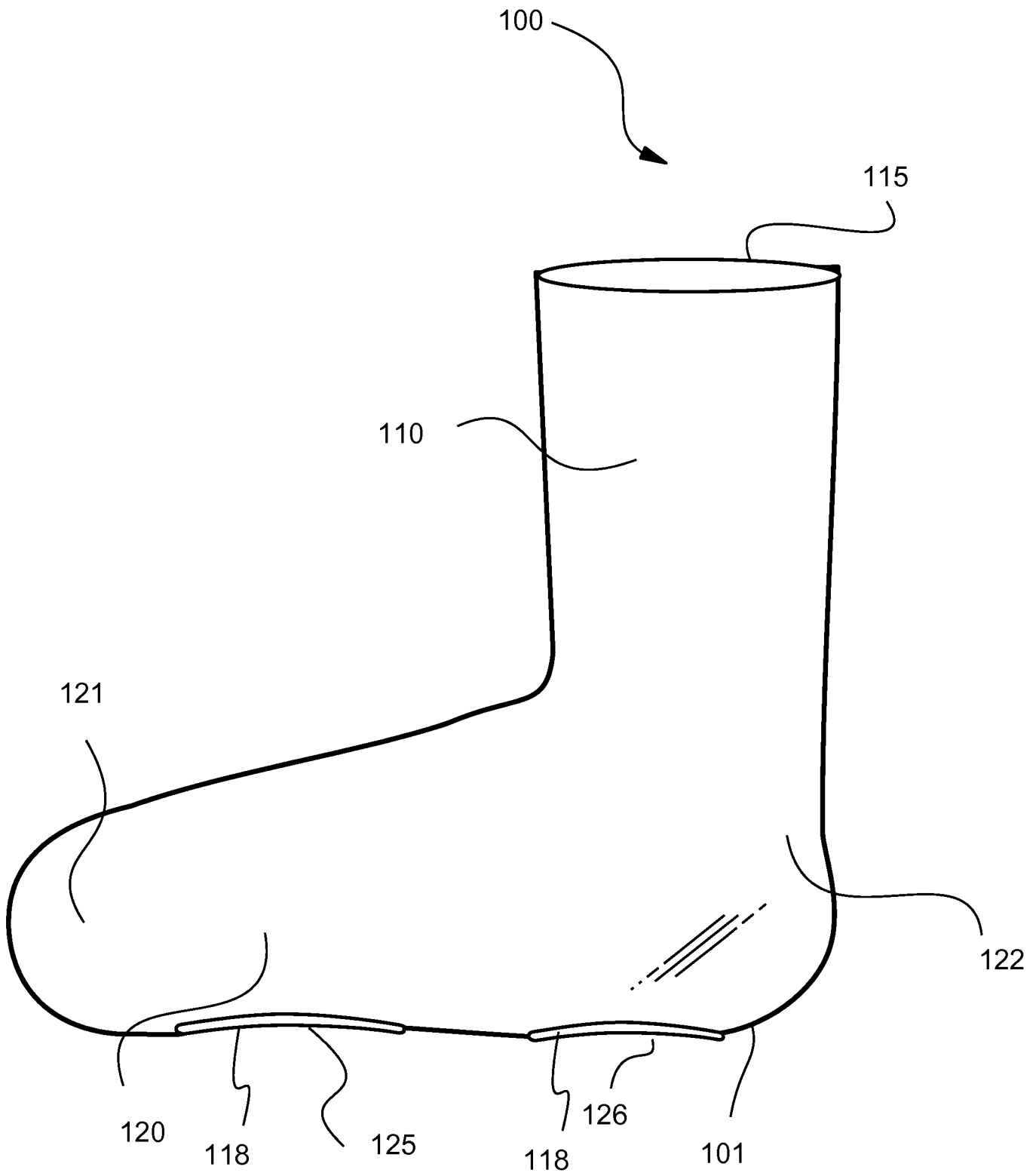

FIG. 6C

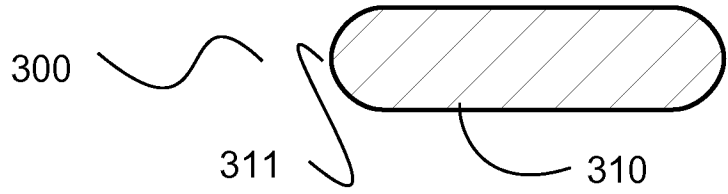

FIG. 6B

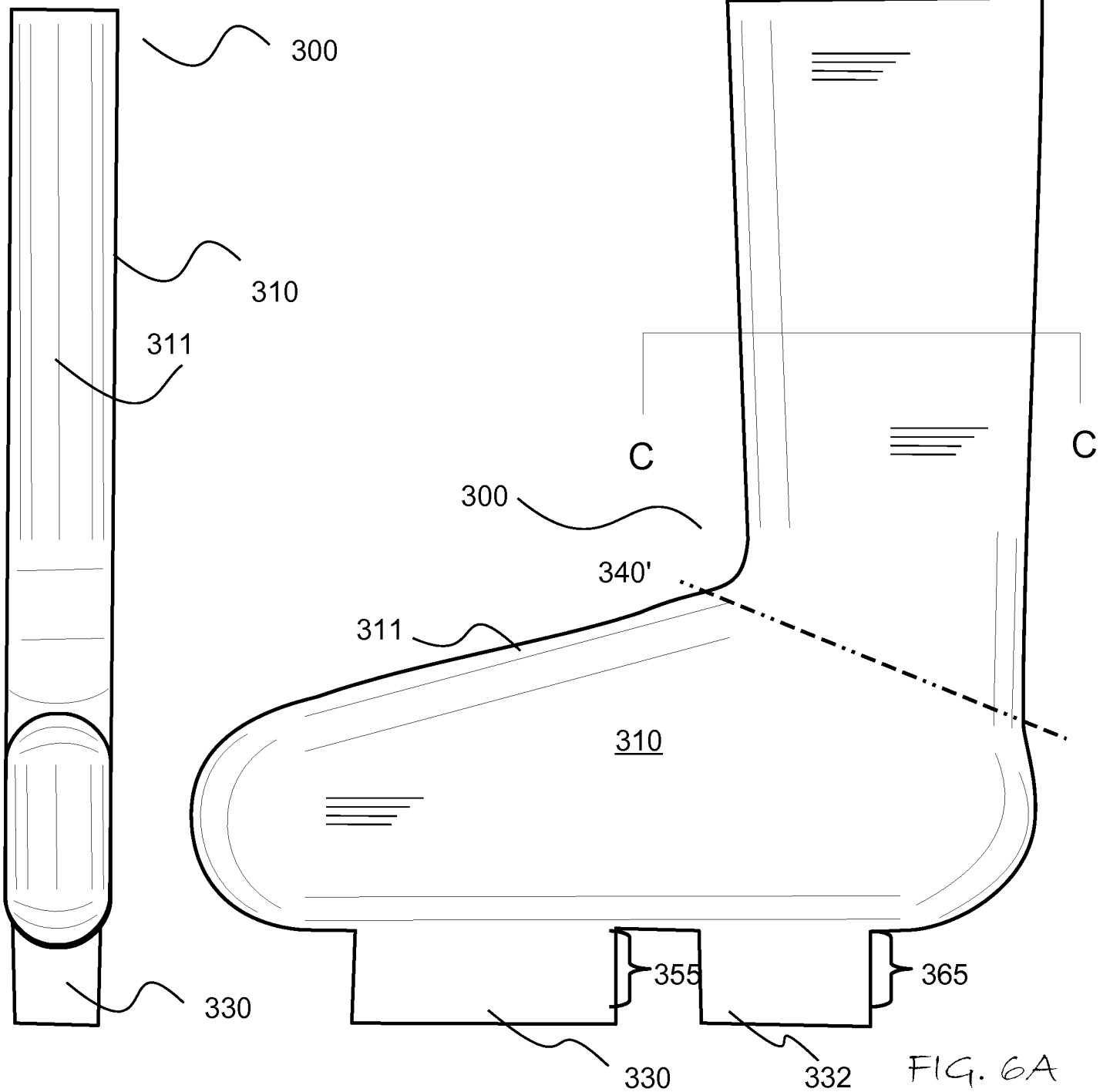

FIG. 6A

FIG. 7

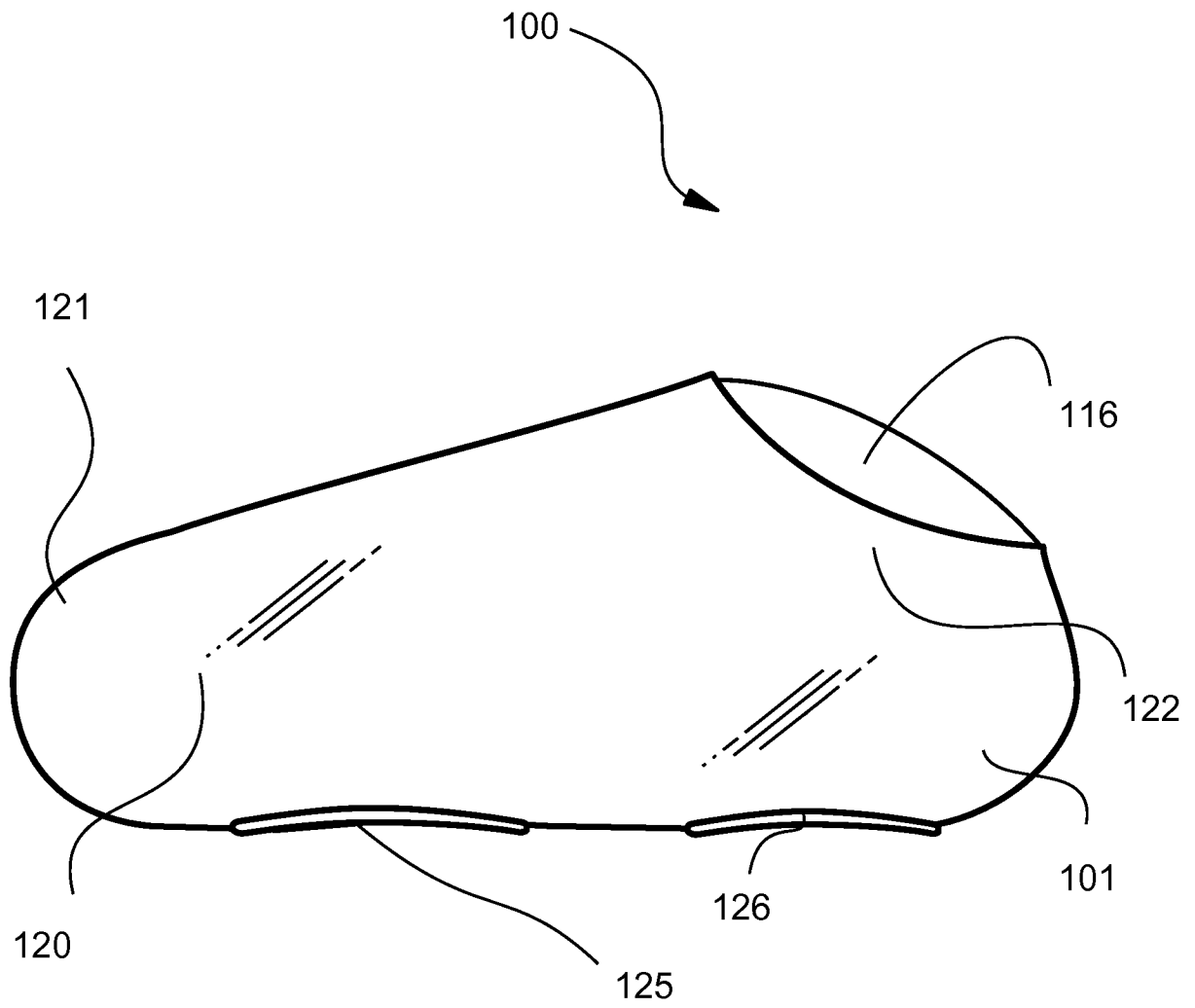
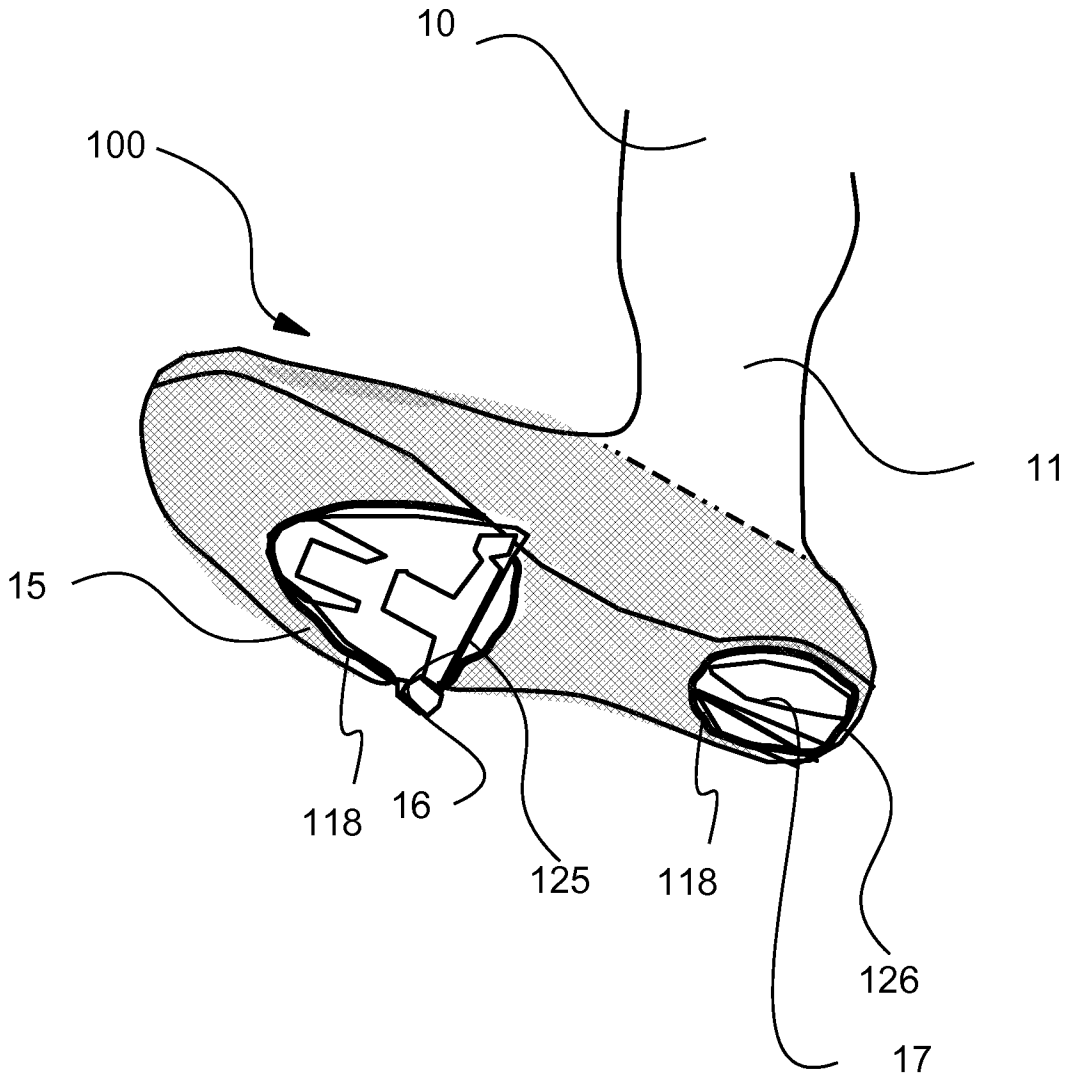

FIG. 8



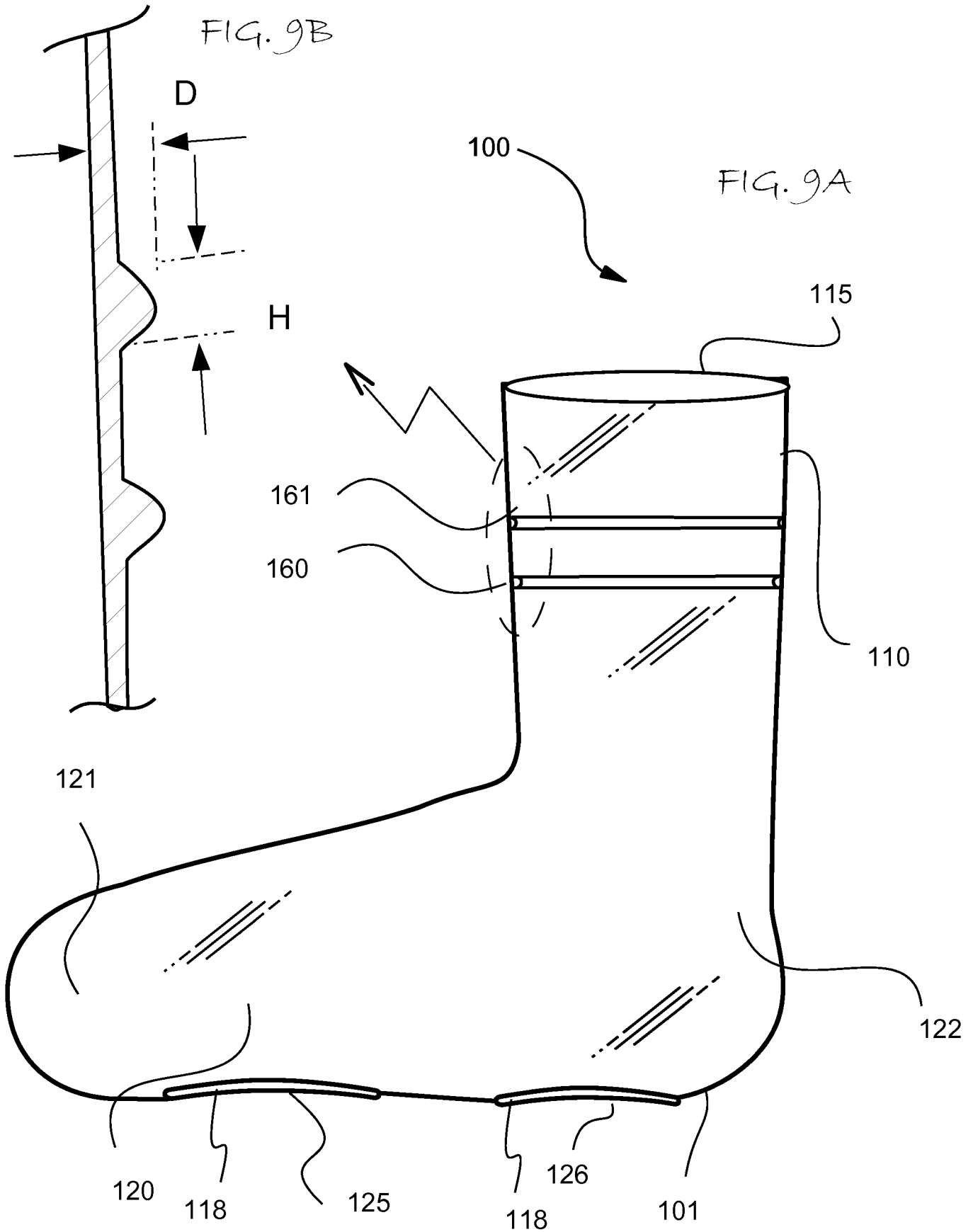

FIG. 10C

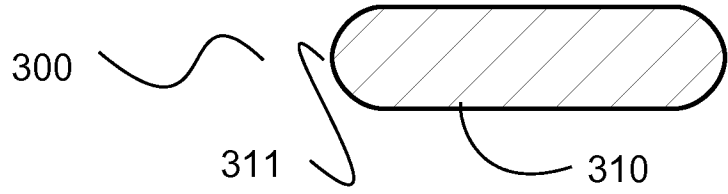

FIG. 10B

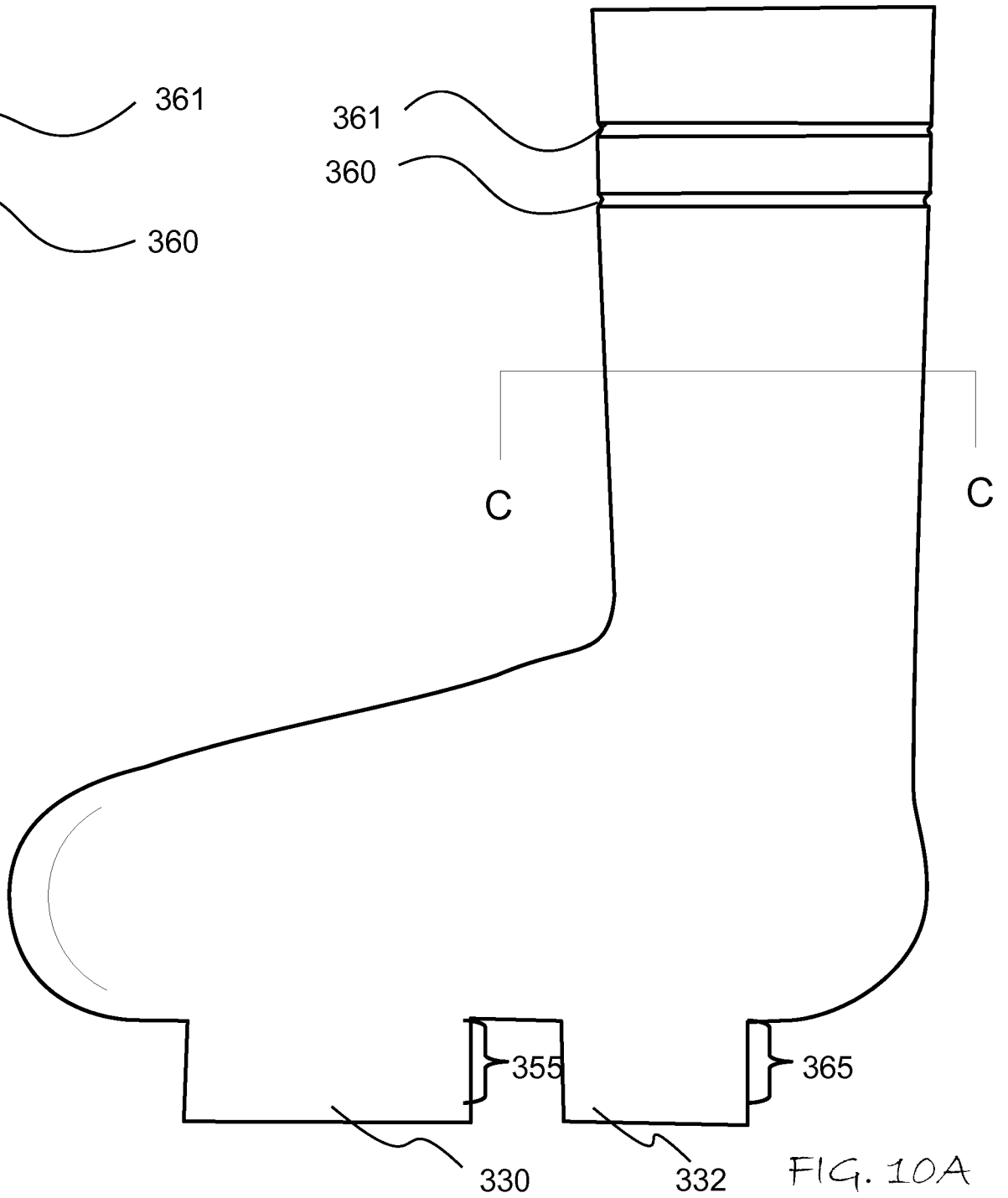

FIG. 10A

FIG. 11C

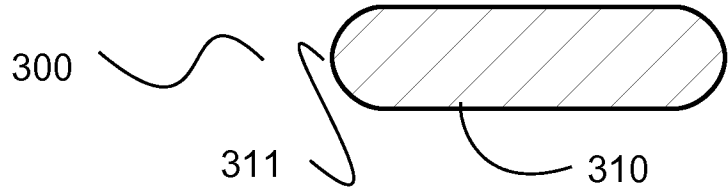

FIG. 11B

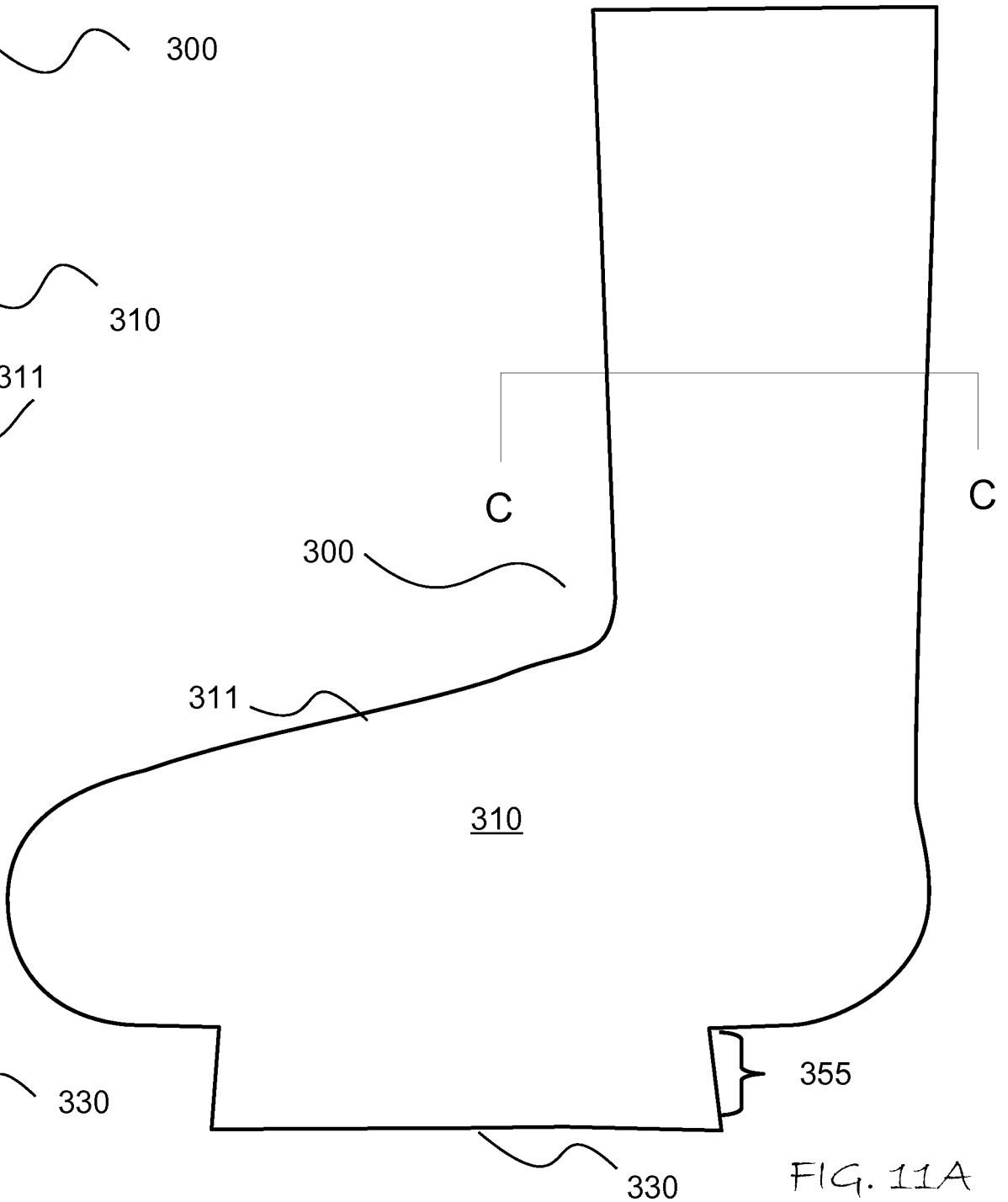
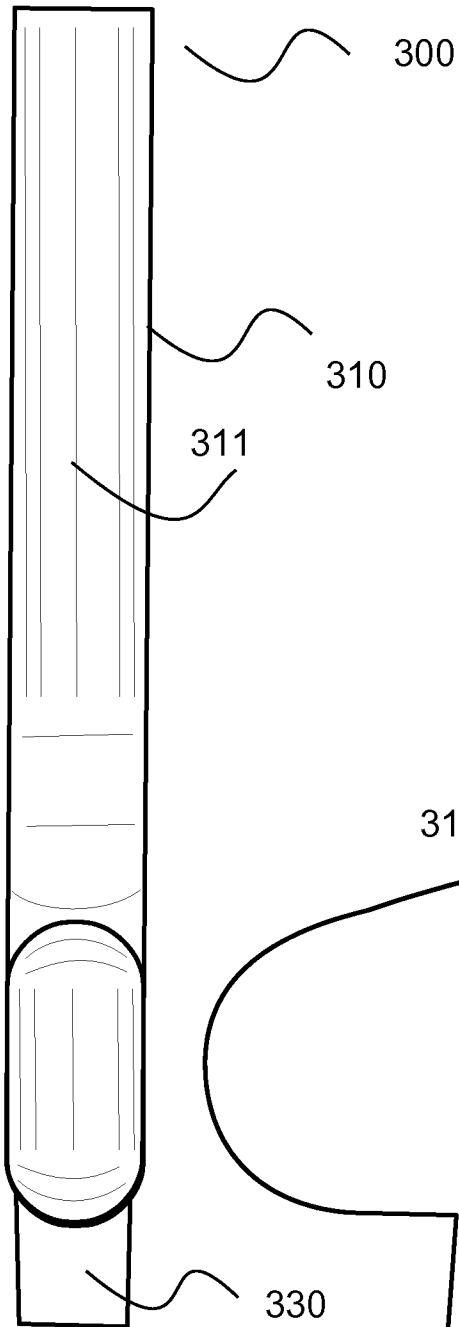

FIG. 11A

FIG. 12

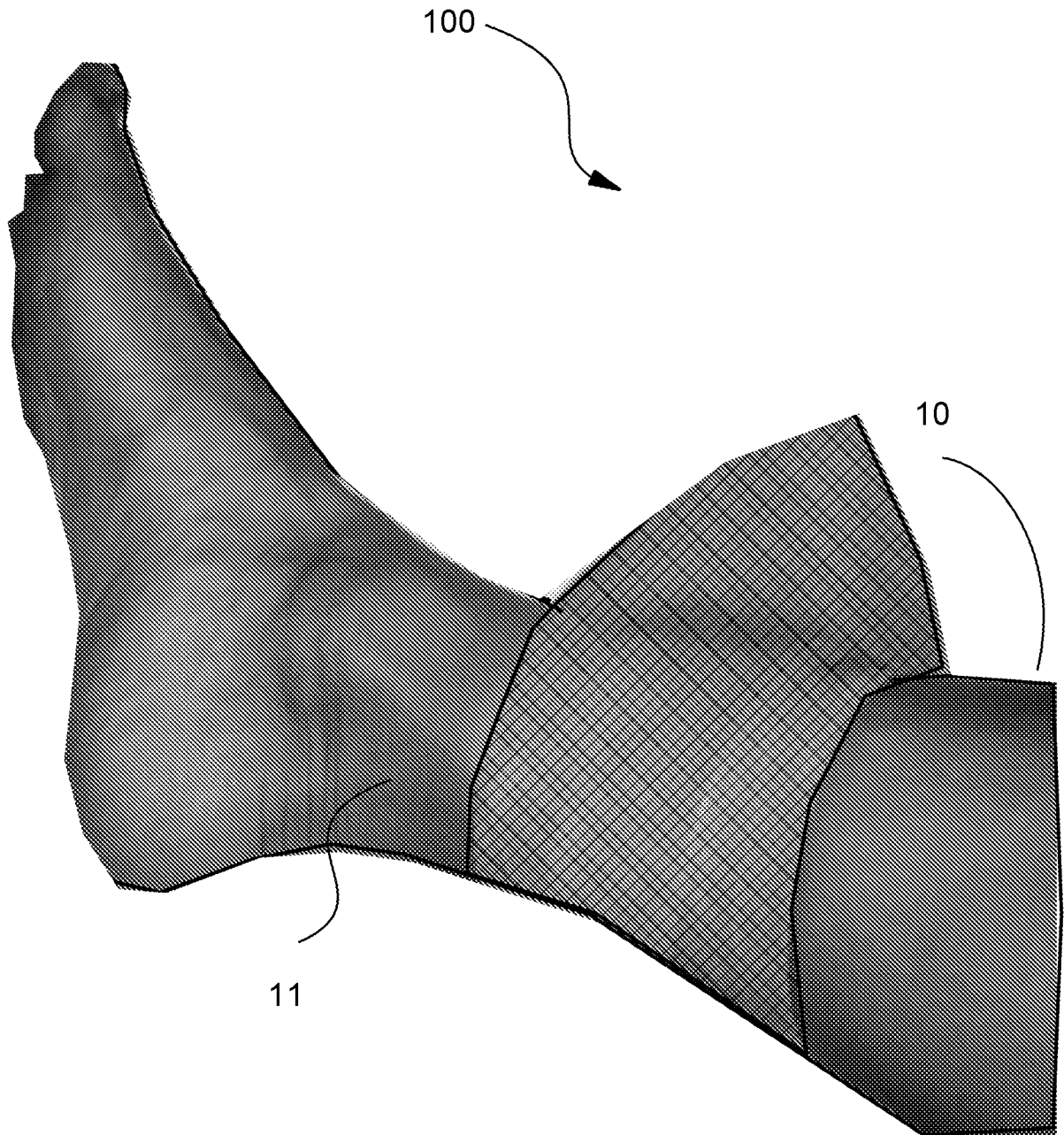

FIG. 13

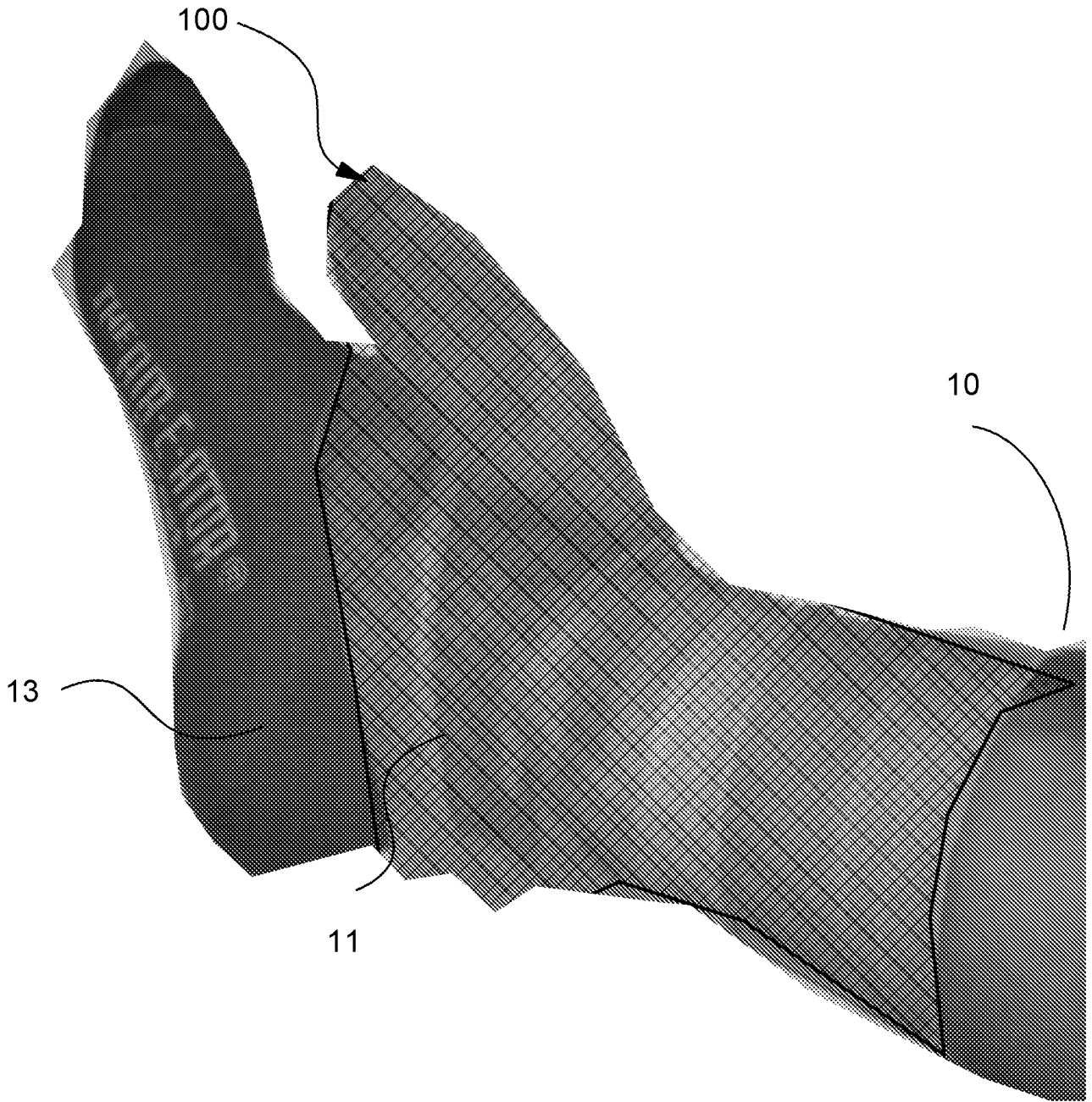

FIG. 14

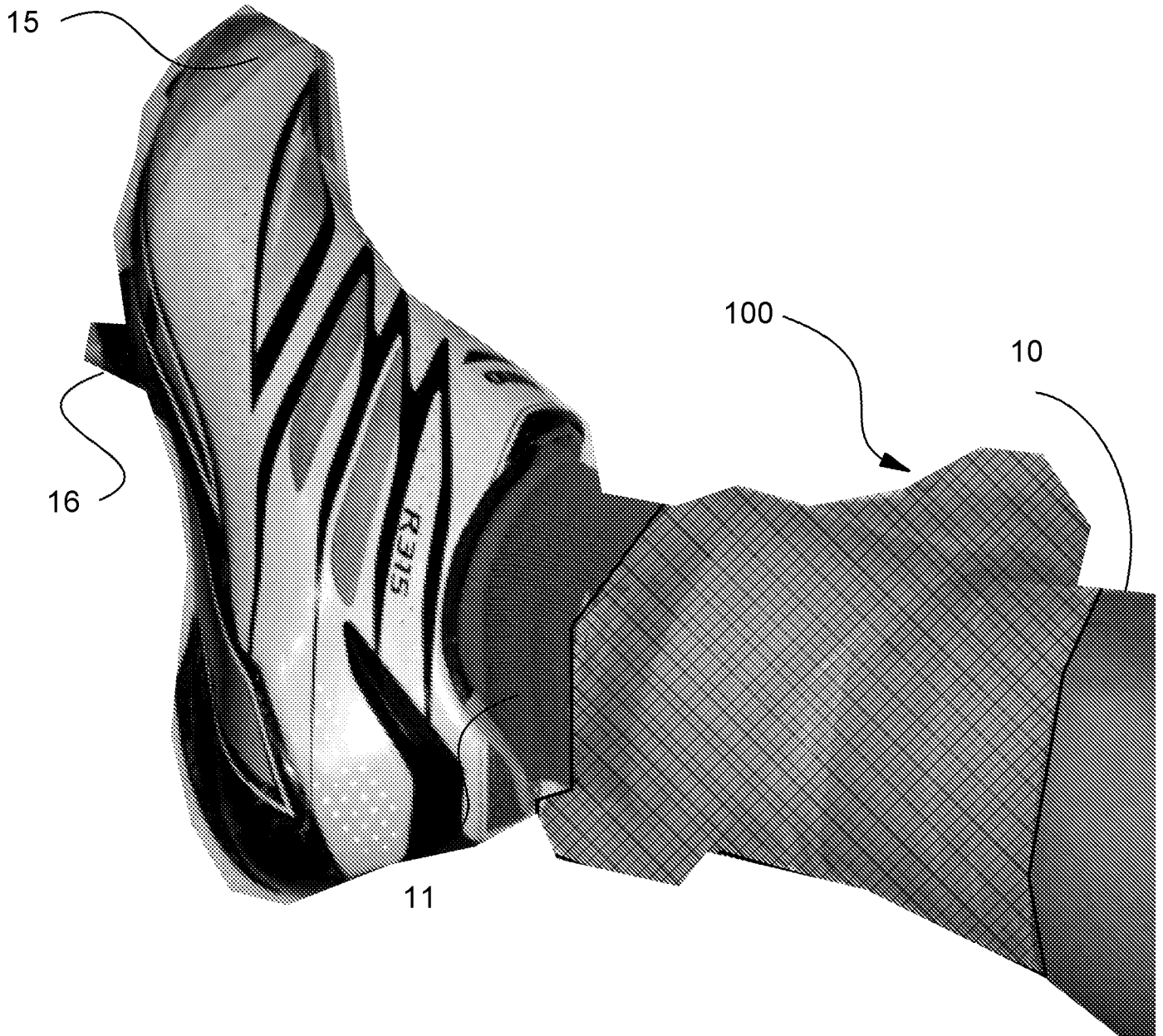

FIG. 15

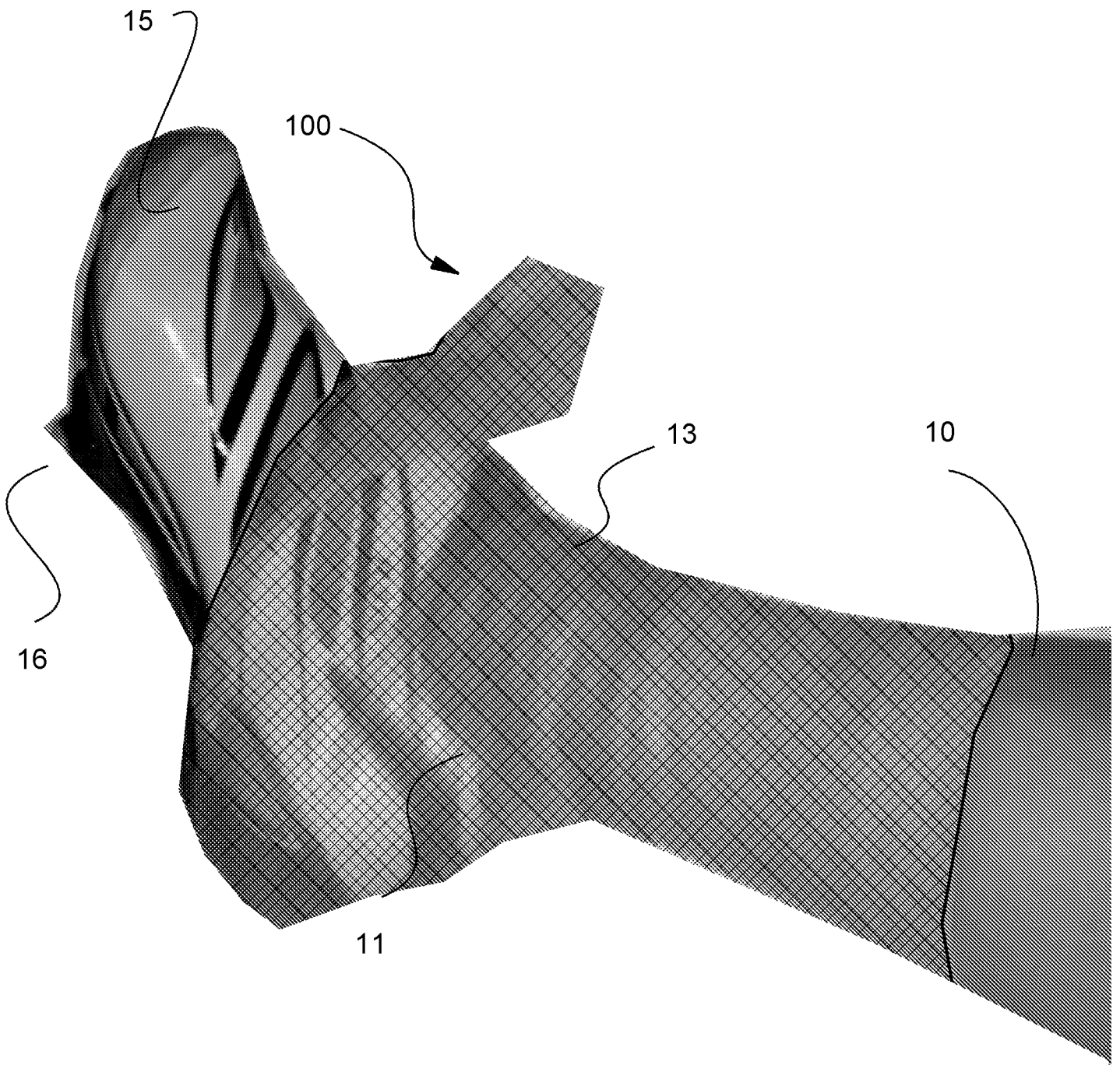

FIG. 16

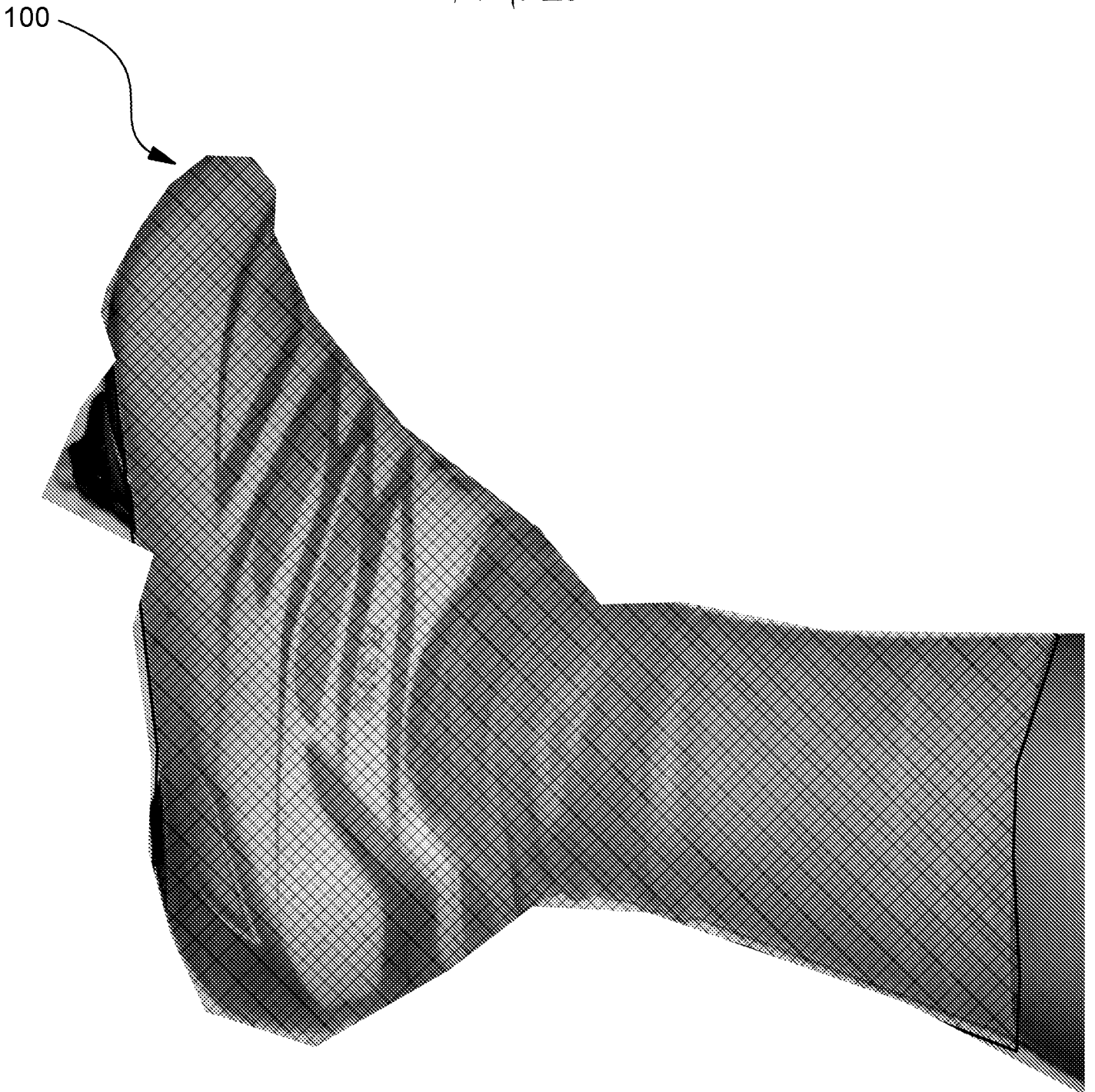
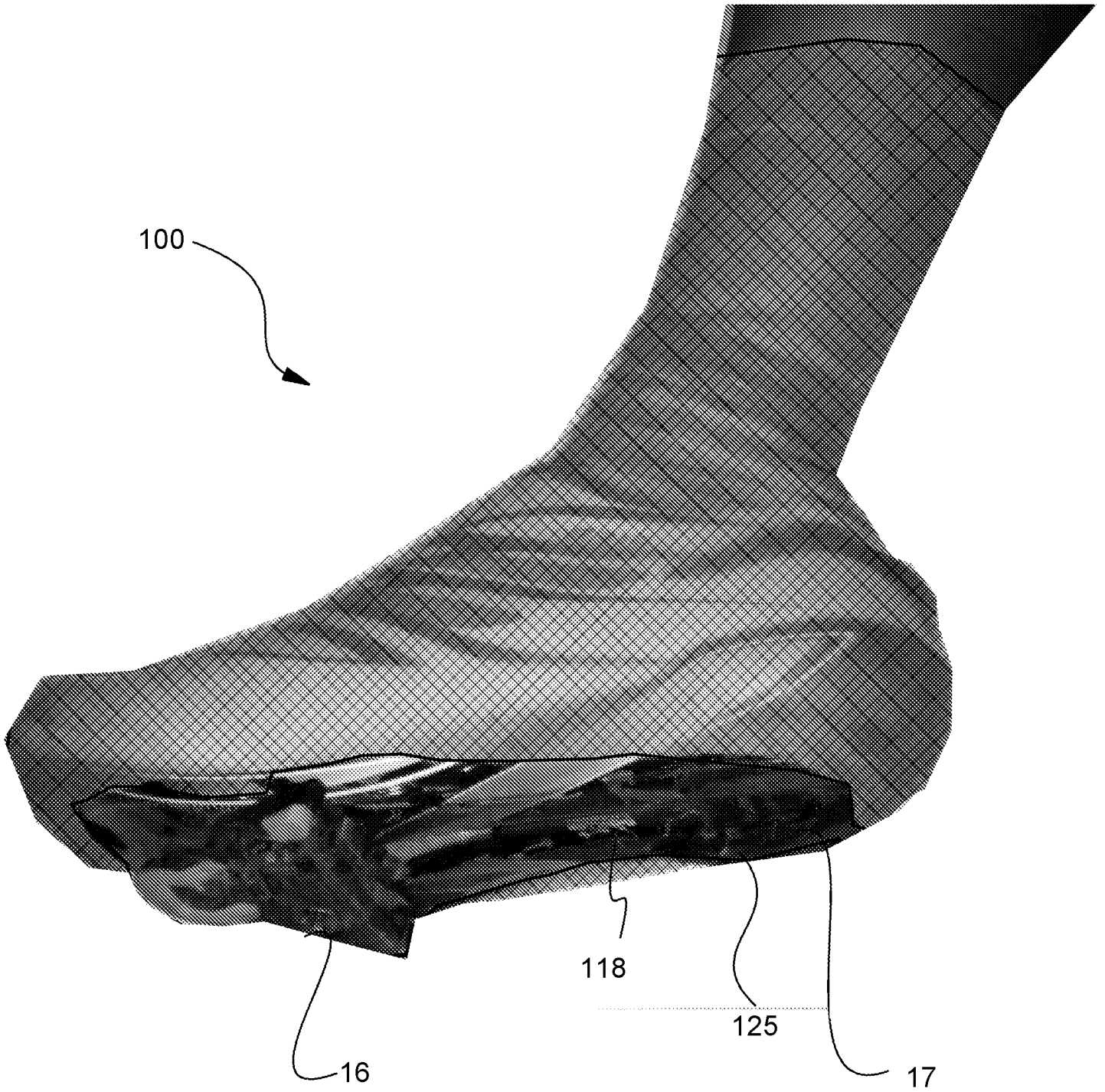

FIG. 17



INTERNATIONAL SEARCH REPORT

International application No.

PCT/US 2014/012054

A. CLASSIFICATION OF SUBJECT MATTER		
<i>A43B 3/16 (2006.01)</i>		
According to International Patent Classification (IPC) or to both national classification and IPC		
B. FIELDS SEARCHED		
Minimum documentation searched (classification system followed by classification symbols)		
A41B 11/00-11/14, A43B 23/00-23/30, 3/16		
Documentation searched other than minimum documentation to the extent that such documents are included in the fields searched		
Electronic data base consulted during the international search (name of data base and, where practicable, search terms used)		
Information Retrieval System of FIPS, Espacenet, USPTO		
C. DOCUMENTS CONSIDERED TO BE RELEVANT		
Category*	Citation of document, with indication, where appropriate, of the relevant passages	Relevant to claim No.
Y A	US 2011/0023215 A1 (DAVIDDA PTY LTD) 03.02.2011, claims, fig. 1-16	1-16, 21-25 17-20
Y	US 7682326 B2 (HAN JI CORPORATION) 23.03.2010, col. 4, claims, fig. 3-10	1-14, 21-25
Y	RU 2306118 C2 (PROTSKO VIKTOR GENNADIEVICH et al.) 20.09.2007, p.4, lines 37-53, fig. 3	15, 16
Y	RU 108961 U1 (OBSHESTVO S OGRANICHENNOY OTVETSTVENNOSTYU "SAMARIN") 10.10.2011, claims, fig. 1-4	3-14, 23-25
<input type="checkbox"/> Further documents are listed in the continuation of Box C. <input type="checkbox"/> See patent family annex.		
* Special categories of cited documents:		
"A"	document defining the general state of the art which is not considered to be of particular relevance	"T" later document published after the international filing date or priority date and not in conflict with the application but cited to understand the principle or theory underlying the invention
"E"	earlier document but published on or after the international filing date	"X" document of particular relevance; the claimed invention cannot be considered novel or cannot be considered to involve an inventive step when the document is taken alone
"L"	document which may throw doubts on priority claim(s) or which is cited to establish the publication date of another citation or other special reason (as specified)	"Y" document of particular relevance; the claimed invention cannot be considered to involve an inventive step when the document is combined with one or more other such documents, such combination being obvious to a person skilled in the art
"O"	document referring to an oral disclosure, use, exhibition or other means	"&" document member of the same patent family
"P"	document published prior to the international filing date but later than the priority date claimed	
Date of the actual completion of the international search		Date of mailing of the international search report
15 May 2014 (15.05.2014)		19 June 2014 (19.06.2014)
Name and mailing address of the ISA/ FIPS Russia, 123995, Moscow, G-59, GSP-5, Berezhkovskaya nab., 30-1		Authorized officer
Facsimile No. +7 (499) 243-33-37		L. Sukhanovskaya
		Telephone No. (495)531-64-81

Box No. II Observations where certain claims were found unsearchable (Continuation of item 2 of first sheet)

This international search report has not been established in respect of certain claims under Article 17(2)(a) for the following reasons:

1. Claims Nos.:
because they relate to subject matter not required to be searched by this Authority, namely:

2. Claims Nos.:
because they relate to parts of the international application that do not comply with the prescribed requirements to such an extent that no meaningful international search can be carried out, specifically:

3. Claims Nos.:
because they are dependent claims and are not drafted in accordance with the second and third sentences of Rule 6.4(a).

Box No. III Observations where unity of invention is lacking (Continuation of item 3 of first sheet)

This International Searching Authority found multiple inventions in this international application, as follows:

The requirement of unity of invention is violated in the application. According to Rule 13.2 of Regulations under the Patent Cooperation Treaty (PCT) the requirement of unity of invention is considered to be ensured, if there is a technical interconnection between the claimed inventions; wherein this technical interconnection is determined by one or more the same or corresponding special technical features defining the contribution of each of inventions to the prior art.

The inventions can be divided in the following groups relative to the special technical features.

First group of inventions: independent claims 1, 17, 21 - the special technical features are forming an elliptical opening on a lower portion of a second tubular portion of the product.

Second group of invention: independent claim 15 - the special technical feature is the die for forming a sock like protective cover.

Comparison of the inventions of two groups shows that the first group of inventions and the second group of inventions are not connected by each other with the same or corresponding special technical features. The unity of inventions is lacked.

1. As all required additional search fees were timely paid by the applicant, this international search report covers all searchable claims.
2. As all searchable claims could be searched without effort justifying additional fees, this Authority did not invite payment of additional fees.
3. As only some of the required additional search fees were timely paid by the applicant, this international search report covers only those claims for which fees were paid, specifically claims Nos.:

4. No required additional search fees were timely paid by the applicant. Consequently, this international search report is restricted to the invention first mentioned in the claims; it is covered by claims Nos.:

Remark on Protest

- The additional search fees were accompanied by the applicant's protest and, where applicable, the payment of a protest fee.
- The additional search fees were accompanied by the applicant's protest but the applicable protest fee was not paid within the time limit specified in the invitation.
- No protest accompanied the payment of additional search fees.