

(No Model.)

3 Sheets—Sheet 1.

J. GRAHAM.  
SMOKE CONSUMING FURNACE.

No. 521,586.

Patented June 19, 1894.

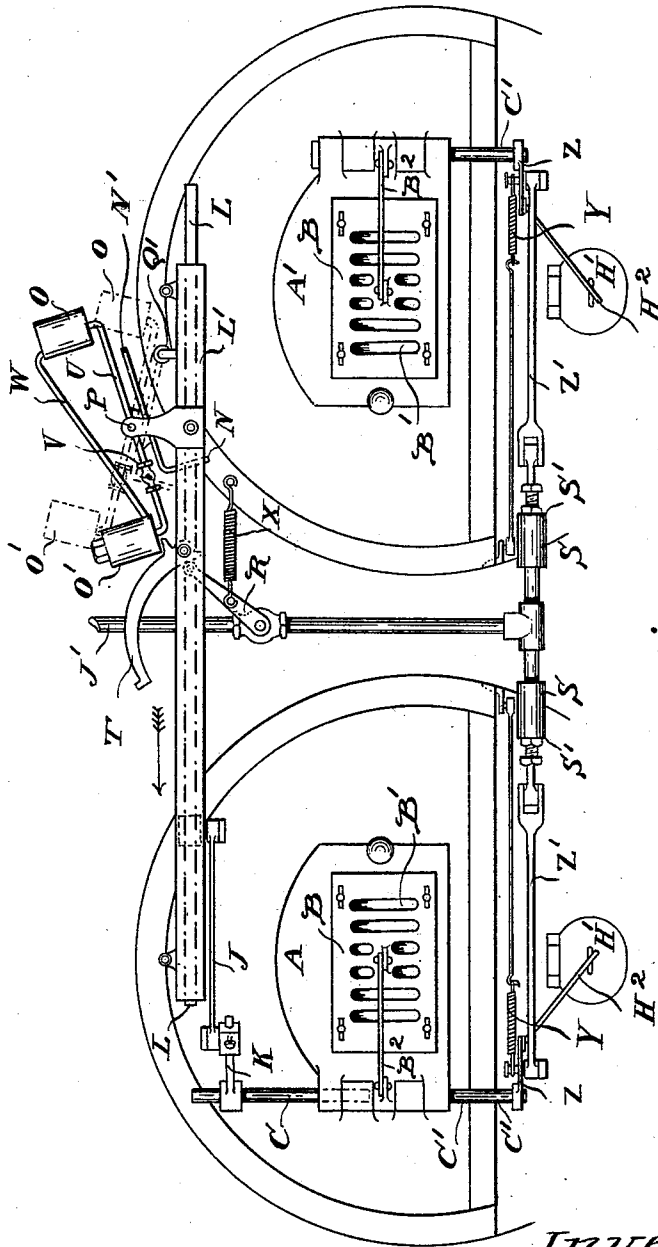

Fig. 1.

Witnesses:

E. B. Bolton

J. B. van Oldensteel

Inventor:  
Jesse Graham

By *Richard A. Lee*  
his Attorneys.

J. GRAHAM.  
SMOKE CONSUMING FURNACE.

No. 521,586.

Patented June 19, 1894.

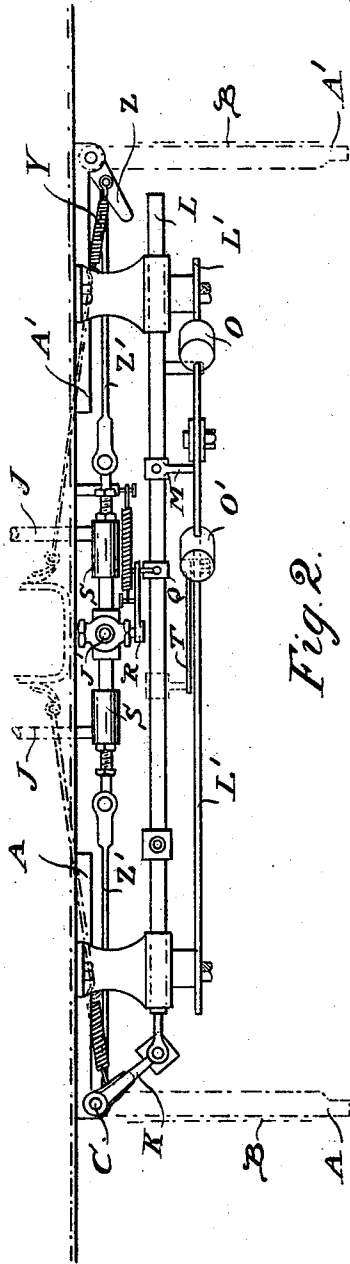

Fig. 2.

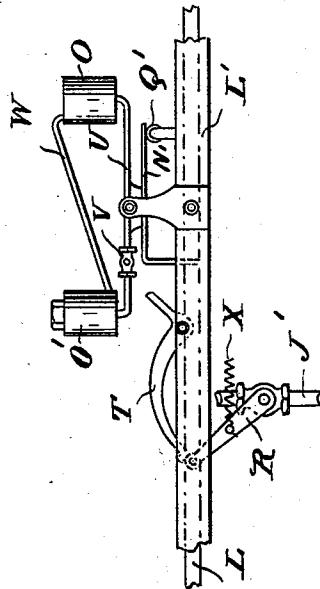

Fig. 3.

Inventor:  
Jesse Graham

By *Richardson*  
his Attorneys.

Witnesses:  
*E. B. Bolton*  
*H. Van Dolenneel*

(No Model.)

3 Sheets—Sheet 3.

J. GRAHAM.  
SMOKE CONSUMING FURNACE.

No. 521,586.

Patented June 19, 1894.

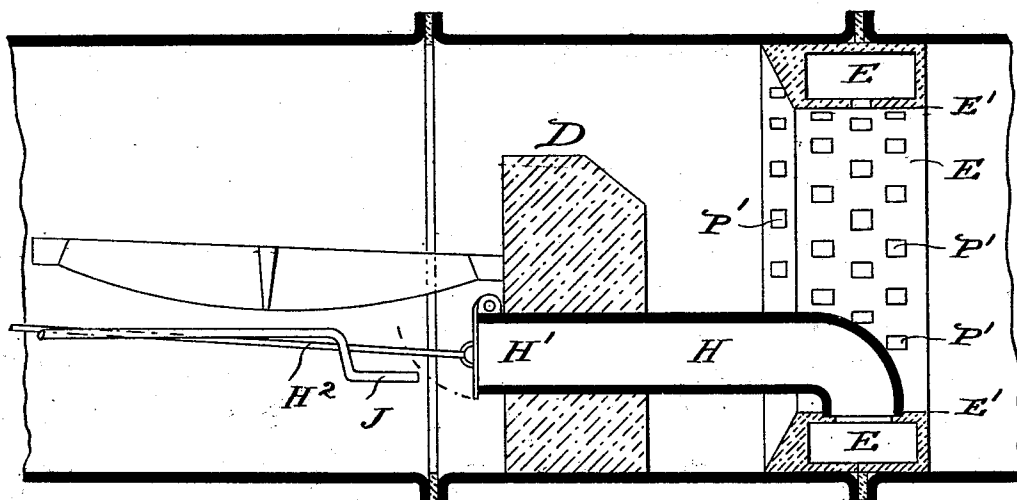

Fig. 4.

Witnesses:

*C. B. Bolton*  
*H. van Oldenneel*

Inventor:

*Jesse Graham*

By *Richard A. Lee*

*his Attorneys.*

# UNITED STATES PATENT OFFICE.

JESSE GRAHAM, OF MORLEY, ENGLAND.

## SMOKE-CONSUMING FURNACE.

SPECIFICATION forming part of Letters Patent No. 521,586, dated June 19, 1894.

Application filed August 1, 1893. Serial No. 482,099. (No model.) Patented in England July 29, 1892, No. 13,793.

*To all whom it may concern:*

Be it known that I, JESSE GRAHAM, a subject of the Queen of Great Britain and Ireland, residing at Morley, in the county of York, England, have invented certain Improvements in Apparatus for the Consumption of Smoke in the Furnaces of Steam-Boilers and the Like, (for which a patent has been granted to me and Henry Gowan Hudson and William Milne Rennie by the Government of Great Britain and Ireland, No. 13,793, dated July 29, 1892,) of which the following is a specification.

This invention has for its object the more effectual consumption of smoke by combining with a fire box or furnace, an apparatus constructed by the combination of the several parts in such a manner that, after supplying the fire with fuel, a volume of cold air is admitted to the front portion of the furnace, and a volume of air heated and distributed at the back end of the furnace in such a manner that the smoke emitted from the fuel is consumed; also to so arrange the apparatus that the volumes of cold and heated air are automatically stopped when required.

In describing my invention in detail, reference is made to the accompanying drawings, in which—

Figure 1 represents the front view of the furnaces of a boiler fitted with my improvement. Fig. 2 is a plan of such portions of the apparatus as are fitted to the front of a boiler; Fig. 3 a detail of that portion which automatically governs the time the air is allowed to enter the front and back ends of the furnace, and Fig. 4 a sectional detail through the back part of a furnace fitted with the hollow arch portion of the apparatus.

The combined apparatus is shown as applied to a two flued boiler, the furnace doors A and A' of which are each provided with a series of slotted openings and a sliding plate B having similar openings B' cut through same. The hinge pin C of the door A extends about half way down the door and is secured thereto so that, when opened or closed, the hinge pin C is operated. The sliding plate B of each door is connected by a rod B<sup>2</sup> to a short lever secured to the bottom portion C' of the hinge pin. When the door A is opened, the plate B in each door A. and A'. is caused

to slide in the manner as hereinafter described into the position for the slotted openings in the plates to correspond with those through the respective doors for the purpose of admitting cold air to the front of the furnaces when the doors are closed.

Behind the ordinary bridge D of each furnace is a perforated and hollow arch or projection E extending round the flue, and formed of brick or other refractory material, the space between the internal circumference of same at E' E' being unobstructed.

Connected to the hollow portion of the perforated arch E is a pipe H. open at one end to the atmosphere and fitted with a hinged door H' coupled by a rod H<sup>2</sup> to the lever Z secured to hinge pin C'. To the hinge pin C is secured a lever K. coupled by a rod J to bar L. supported by brackets in a manner that the said bar may slide therein. On opening the door A the hinge pin C and lever K are operated, thereby causing the bar L to slide some distance in the direction of arrow, and a projecting pin M, fixed to bar L to come in contact with an arm N and operate same along with the attached vessels O and O' supported on fulcrum pin P. to the position shown by dotted lines. On the bar L sliding in the direction described, another pin Q secured to the said bar comes in contact with the lever R attached to the plug of a tap, in the steam pipe J', and operates the said lever such a distance that steam is allowed to pass and flow into the cylinders S. S. through pipes J. J. and escape through suitable jets into the open end of the respective pipes H. thus inducing a current of air to flow into the heated arches E. which distribute the air in a heated condition by the perforations P' in a manner that it amalgamates with the heated gases of the furnaces escaping over the bridges D. On admitting steam to the cylinders S. S. in the manner described, the piston in each is forced to the end S', thus operating the respective levers Z and hinge pins C' through the connecting rods Z'. The pins C' turning to some extent in the door hinges cause the plates B in the respective doors to slide to the position for the slotted openings to correspond with those in the door, where they remain so long as steam is allowed to flow. The lever R is held in the position for keeping the tap open, by the

end of said lever engaging with a catch bar T supported on a pin secured to fixed bar L'. The vessels O and O' are connected by a pipe W which allows the liquid in the vessels to flow from O' to O, when in the position shown by dotted lines; the said vessels are also connected by a pipe U provided with a tap V for allowing the liquid to flow from vessel O to O' when in the position shown by Fig. 3 after the door has been closed. On closing the door A. the sliding bar L is moved in the opposite direction to that before described. When a support Q' on the bar L sliding under the arm N' moves the vessels to the position shown by Fig. 3, the liquid in the vessel O will then flow into vessel O' through pipe U and regulating tap V. and when the surface of the liquid in the two vessels is about level, the end O' being slightly heavier, causes the vessels to tip to the position shown by full lines in Fig. 1, and on the descent of O'. it strikes one end of catch lever T and thereby liberates the lever R, which is then moved in the direction for closing the tap by the contraction of the spiral spring X. thus stopping the supply of steam. So long as steam is passing through the pipes J. the pistons in the respective cylinders S. S. allow steam to be injected into the respective pipes H. and the air to be distributed in a heated condition through the perforations P' as before described; but when the flow of steam is cut off, the extended spiral springs Y contract, and operate the respective hinge pins C', thus moving the pistons and sliding plates B back to their original position, thereby stopping the supply of air to the back and front of the furnaces. The sliding bar L is not operated by the door A'. which is hinged in the same manner as door A'. the slotted plates B. in the doors being opened and closed in the manner as before described.

What I claim as my invention is—

1. In a smoke consuming furnace the fire box, the air inlet pipe extending in rear of the same, and opening to the atmosphere, the valve or door controlling said open end, the draft plate B at the front of the furnace, the steam jet directed to the air pipe H, the steam cylinder S, the connections therefrom to the draft slide at the front of the furnace and with the valve of the air pipe H, the steam valve and means for operating the same, said means being in connection with the furnace door, substantially as described.

2. In a smoke consuming furnace, the fire box, the air inlet pipe extending in rear of the same and having a valved opening to the atmosphere, the draft plate B at the front of the furnace, the steam jet directed to the air pipe, the steam cylinder S, the connections therefrom to the valve of the air pipe H and to the draft plate B, and the steam valve, substantially as described.

3. In combination in a smoke consuming furnace, the fire box, the perforated arch in rear thereof, the steam jet, the air pipe H leading from said steam jet to the perforated arch, the valve controlling the air pipe H, the connection to the said valve controlled by the pressure of steam, the steam valve for controlling the pressure and the supply to the steam jet and the connection for operating the steam valve extending from the furnace door whereby when said door is opened the steam pressure will open the air valve of pipe H and then supply the steam jet, substantially as described.

4. In combination in a smoke consuming furnace the air pipe H leading into the same, the steam jet directed to the pipe H, the steam supply, the valve controlling the same, the tipping vessels O O' with connections between them, said vessels being arranged to control the closing of the steam valve, the sliding bar L and the connection therefrom to the furnace door to be operated thereby, substantially as described.

5. In combination, in a smoke consuming furnace, the door, the draft slide B thereon, the hinge pin C connected to and movable with the door, the hinge pin C' arranged to have movement independent of the door, the air pipe H extending into the furnace, the steam jet leading thereto, the steam supply and valve, the piston S, connected with the steam supply, the connections from the hinge pin C for operating the steam valve when the door is opened, the valve plate H' for the pipe H, and the connections from the piston S to the hinge pin C', and the valve plate H', substantially as described.

6. In combination in a smoke consuming furnace, the door A having the draft slide B thereon and the hinge pin C rigidly connected to turn with the door, the air pipe H having a valve plate H', the piston having connection with the valve plate and with the movable hinge pin C' connected with the draft slide, the sliding bar L connected with the hinge pin C, the steam valve, the steam pipe extending therefrom to the piston and to the steam jet leading into the air pipe H, the lever R of the steam valve arranged to be operated by the movement of the bar L to open the steam valve, the catch T for holding the lever R in open position and the tipping device O O' arranged to be operated by the movement of the sliding bar for releasing the catch, substantially as described.

In testimony whereof I have signed my name to this specification in the presence of two subscribing witnesses.

JESSE GRAHAM.

Witnesses:

JNO. GILL,  
WM. PREST.