

Dec. 28, 1965

E. A. HAYDEN ETAL

3,225,799

LUMBER SAWING ATTACHMENT FOR PORTABLE CHAIN SAW

Filed Jan. 10, 1961

6 Sheets-Sheet 3

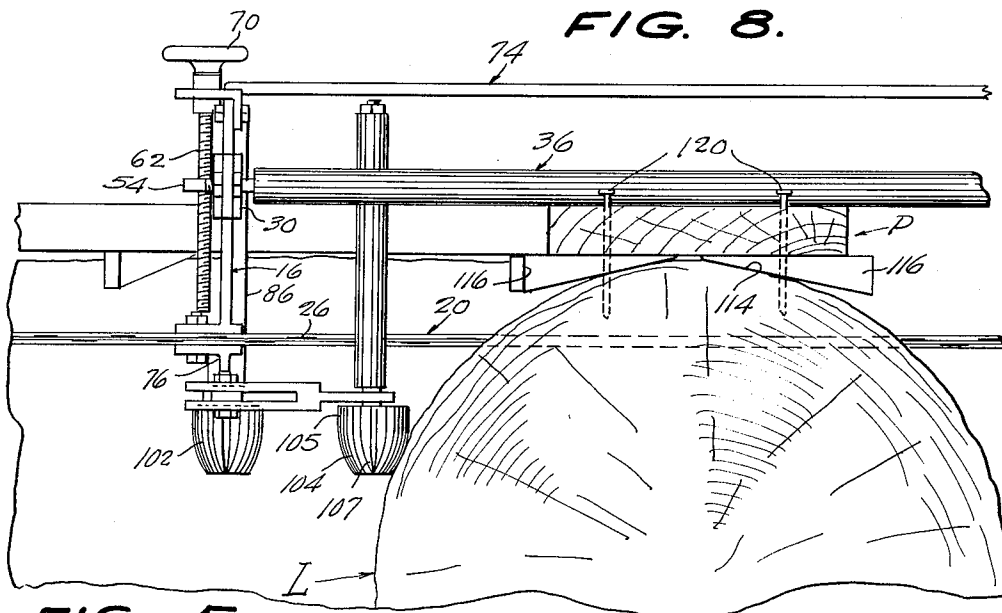

FIG. 5.

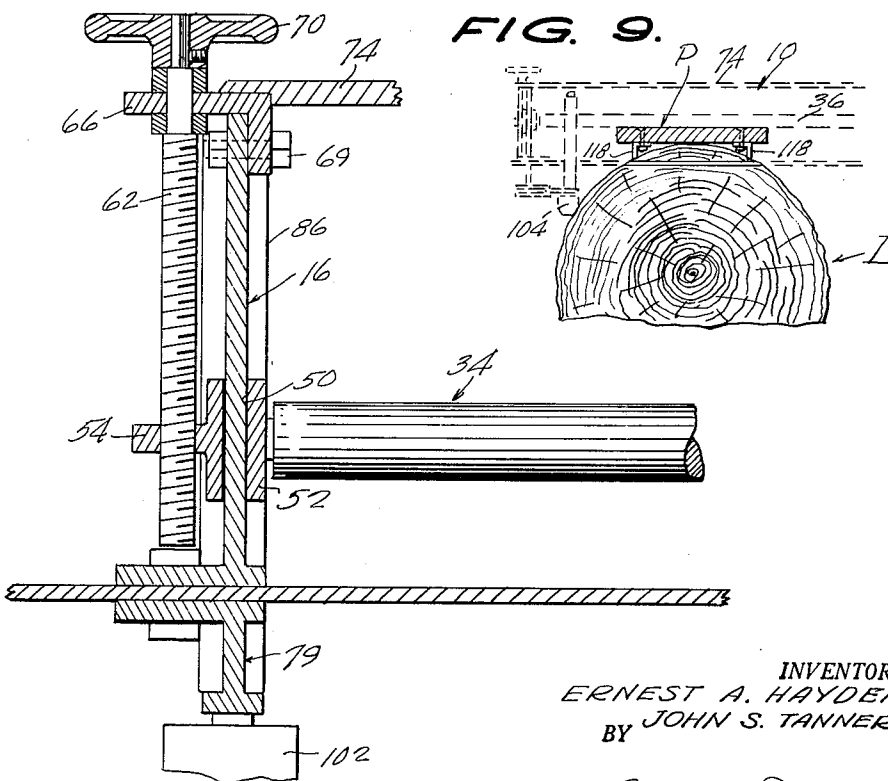

FIG. 9.

INVENTOR.
ERNEST A. HAYDEN,
BY JOHN S. TANNER,

McMorrow, Berman + Davidson
ATTORNEYS.

Dec. 28, 1965

E. A. HAYDEN ETAL

3,225,799

LUMBER SAWING ATTACHMENT FOR PORTABLE CHAIN SAW

Filed Jan. 10, 1961

6 Sheets-Sheet 4

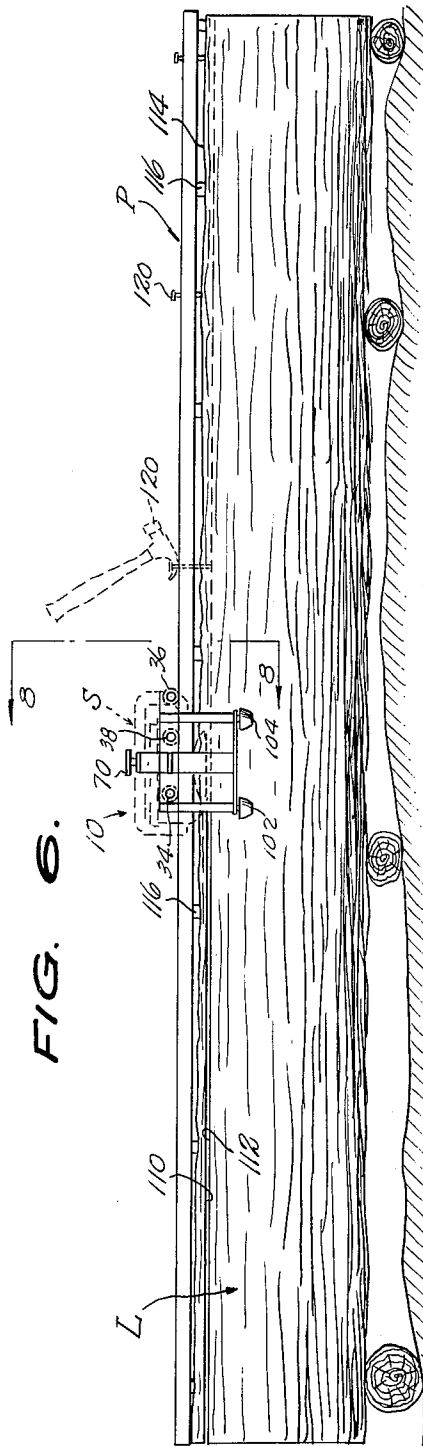

FIG. 6.

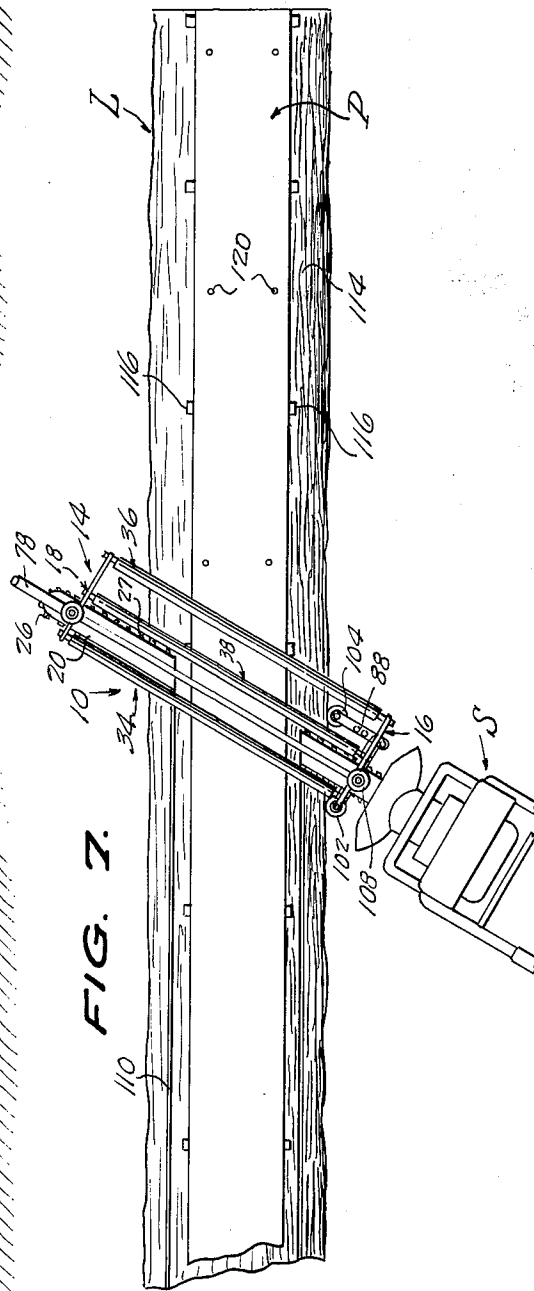

FIG. 7.

INVENTORS
ERNEST A. HAYDEN,
BY JOHN S. TANNER,

McMorrow, Berman & Davidson
ATTORNEYS.

Dec. 28, 1965

E. A. HAYDEN ETAL

3,225,799

LUMBER SAWING ATTACHMENT FOR PORTABLE CHAIN SAW

Filed Jan. 10, 1961

6 Sheets-Sheet 5.

FIG. 10.

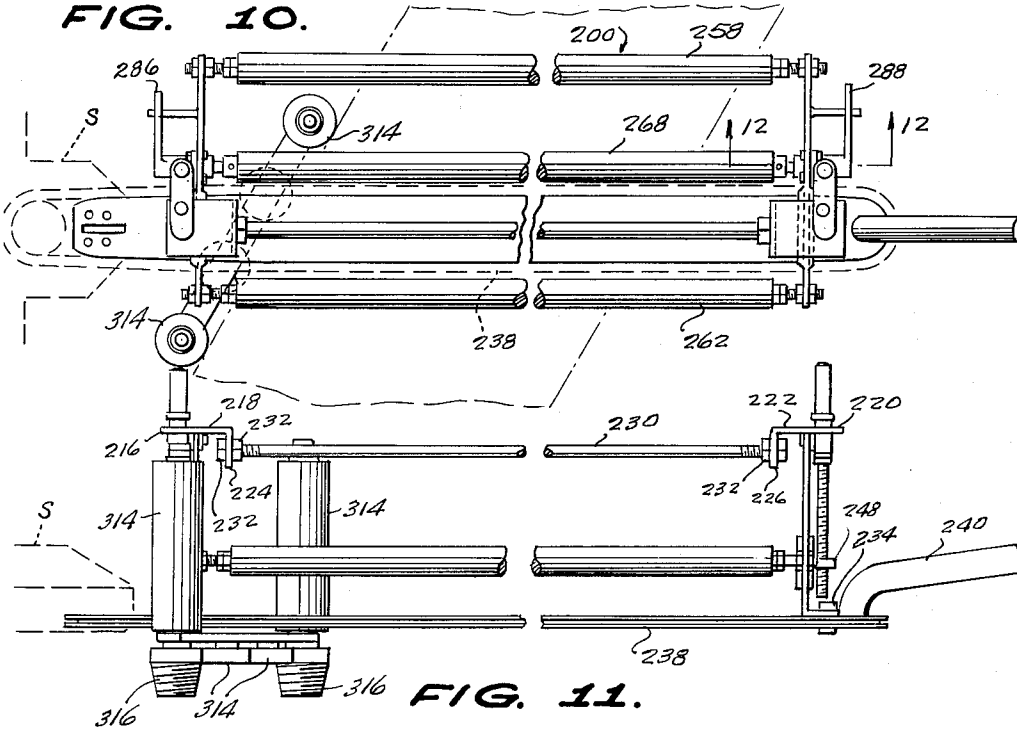

FIG. 11.

FIG. 13.

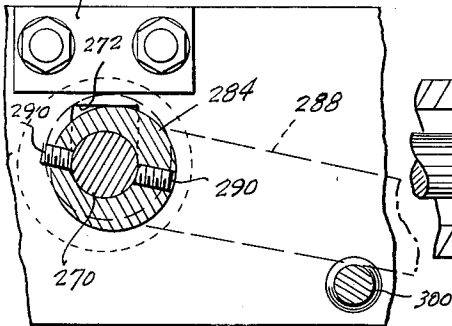

FIG. 12.

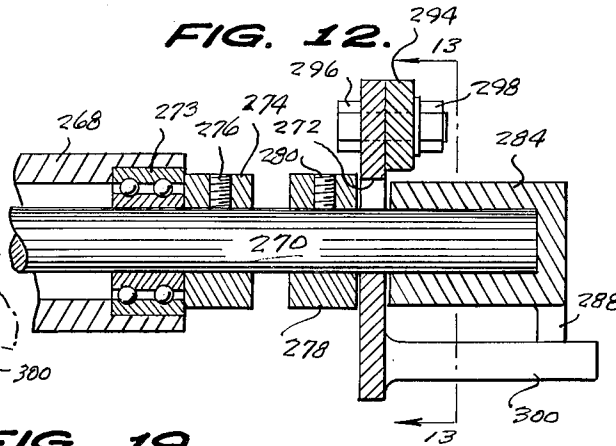
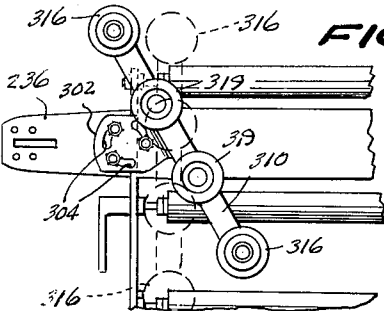

FIG. 19.



INVENTORS
ERNEST A. HAYDEN
JOHN S. TANNER,
BY

McMorrow, Berman & Davidson
ATTORNEYS.

Dec. 28, 1965

E. A. HAYDEN ETAL

3,225,799

LUMBER SAWING ATTACHMENT FOR PORTABLE CHAIN SAW

Filed Jan. 10, 1961

6 Sheets-Sheet 6

FIG. 14.

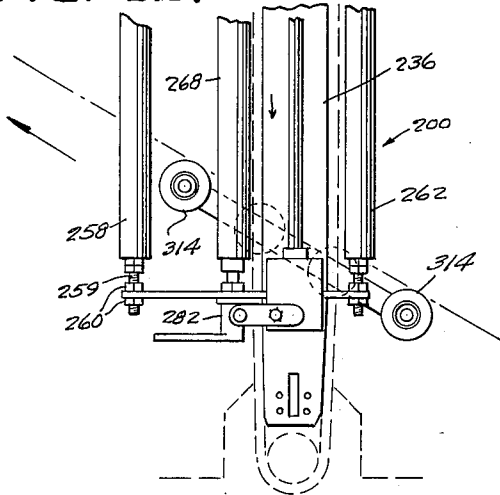

FIG. 16.

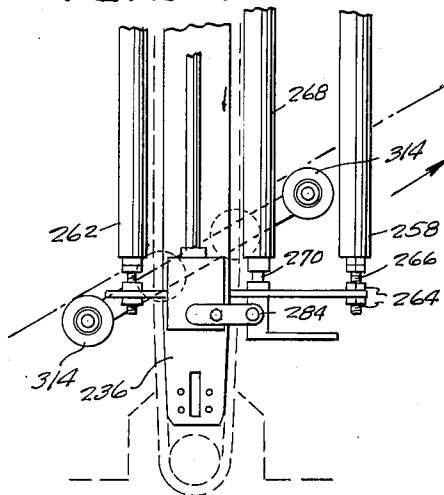

FIG. 15.

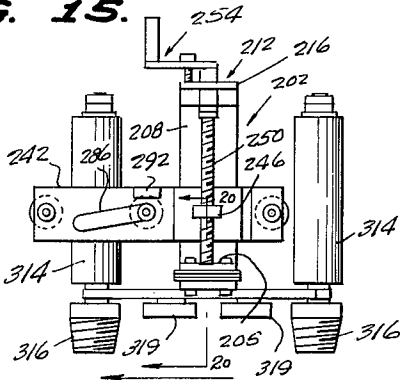

FIG. 17.

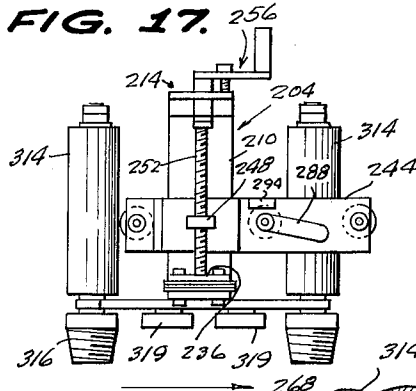

FIG. 18.

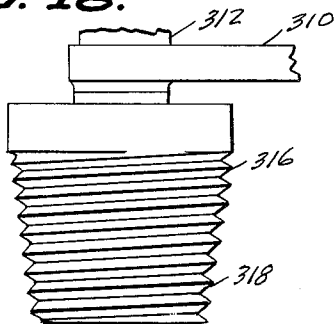
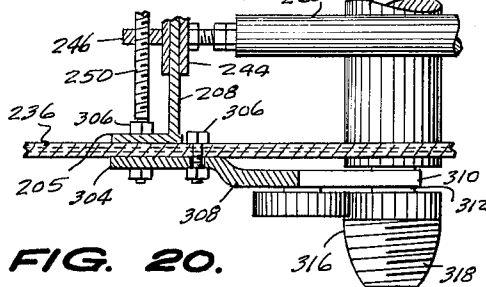

FIG. 20.



INVENTORS
ERNEST A. HAYDEN,
JOHN S. TANNER,
BY

McMurray, Berman & Davidson
ATTORNEYS.

1

2

3,225,799

**LUMBER SAWING ATTACHMENT FOR
PORTABLE CHAIN SAW**

**Ernest A. Hayden, P.O. Box 248, Callahan, Calif., and
John S. Tanner, Auke Bay, Alaska; said Tanner assignor
to said Hayden**

Filed Jan. 10, 1961, Ser. No. 81,899

19 Claims. (Cl. 143—32)

This invention relates to a portable novel chain saw assembly for sawing reclining logs lengthwise, and for other sawing operations, and comprises a continuation-in-part of our co-pending application having the same title, bearing Serial No. 853,586, filed November 17, 1959.

One of the primary objects of this invention is to provide an efficient, compact, lightweight, and easily used chain saw assembly which may be carried by one man into remote and relatively inaccessible areas to which present sawing equipment of the kind cannot be feasibly transported and used, and which thereby renders feasible and profitable the preparation of lumber in such areas.

Another object of the invention is to provide a device of the character indicated above which is readily adjustable to saw through logs and other wood forms, so as to produce forms which are of desired width and thickness, and which have flat sides that are parallel or angled to each other, or sides which are convex or concave, so that the device can be used in furniture and cabinet making, in bridge building, and log cabin construction work.

A still further object of this invention is to provide a chain saw assembly of the type generally referred to above, the assembly including roller mounting means for supporting the assembly on a log during the sawing operation, the mounting means including a plurality of rollers mounted in laterally-spaced relation relative to each other with the respective axes being disposed in parallel relationship, and wherein said roller mounting assembly includes at least one floating roller.

A still further object of this invention is to provide a roller thrust unit for a chain saw assembly of the type described briefly supra, the thrust unit including leading and trailing vertically-mounted rollers for engagement against the side of a log.

It is still another object of this invention to provide a roller thrust unit for a device of the type described wherein the unit includes leading and trailing thrust rollers mounted on a common bar and pivotally connected to the chain saw assembly and, additionally, a plurality of independent rollers disposed below said vertical thrust rollers and subtended from the bar.

This invention contemplates, as a still further object thereof, a chain saw assembly including a thrust unit wherein the chain saw assembly is interchangeable to permit the device to lead from left to right, or right to left according to the direction of drive of the chain saw.

This invention has, as a still further object, the provision of a chain saw assembly of the type referred to above, that is non-complex in construction and assembly, is composed of a small number of simple and easily assembled parts, and which may be made in rugged and serviceable forms at relatively low cost.

Other and further objects and advantages of the instant invention will become more apparent from the consideration of the following specification when read in conjunction with the annexed drawings, in which:

FIGURE 1 is a top plan view of a chain saw assembly constructed in accordance with the present invention, part of the chain saw structure being shown and broken away;

FIGURE 2 is a side elevational view of the device shown in FIGURE 1;

FIGURE 3 is an enlarged vertical section, partly in cross-section, FIGURE 3 being taken substantially on the vertical plane of line 3—3 of FIGURE 2, looking in the direction of the arrows;

FIGURE 4 is a fragmentary horizontal cross-sectional view, FIGURE 4 being taken substantially on the horizontal plane of line 4—4 of FIGURE 3, looking in the direction of the arrows;

FIGURE 5 is a fragmentary cross-sectional view, FIGURE 5 being taken substantially on the vertical plane of line 5—5 of FIGURE 3, looking in the direction of the arrows;

FIGURE 6 is a schematic view in side elevation illustrating the device applied to a log in conjunction with an initial cut sawing guide;

FIGURE 7 is a top plan view of FIGURE 6;

FIGURE 8 is an enlarged fragmentary sectional end view, FIGURE 8 being taken on the vertical plane of line 8—8 of FIGURE 6;

FIGURE 9 is an end elevation of FIGURE 6 on a reduced scale and showing details of the sawing guide;

FIGURE 10 is a top plan view of a second embodiment of this invention;

FIGURE 11 is a side elevational view of the device shown in FIGURE 10;

FIGURE 12 is an enlarged fragmentary detail cross-sectional view showing the eccentric locking means for one of the mounting rollers, FIGURE 12 being taken substantially on the horizontal plane of line 12—12 of FIGURE 10, looking in the direction of the arrows;

FIGURE 13 is an enlarged detail cross-sectional view of the eccentric locking means, FIGURE 13 being taken substantially on the vertical plane of line 13—13 of FIGURE 12, looking in the direction of the arrows;

FIGURE 14 is a fragmentary top plan view of the modification shown in FIGURE 10, FIGURE 14 illustrating schematically, the operation of the device in making a cut from right to left;

FIGURE 15 is an end elevational view of the device as illustrated in FIGURE 14;

FIGURE 16 is a fragmentary top plan view similar to FIGURE 14, but illustrating the arrangement and disposition of component elements of the device when making a cut from left to right;

FIGURE 17 is an end elevation view of FIGURE 16;

FIGURE 18 is an enlarged side elevational view of a hold-down roller according to this invention;

FIGURE 19 is a fragmentary bottom plan view of the device shown in FIGURE 10, FIGURE 19 illustrating the means for pivoting or swinging the roller thrust unit; and

FIGURE 20 is an enlarged detail cross-sectional view of the thrust roller assembly, FIGURE 20 being taken substantially on the vertical plane of line 20—20 of FIGURE 15, looking in the direction of the arrows.

Referring now more specifically to the drawings, reference numeral 10 illustrates, in general, a device of the type described constructed in accordance with the teachings of one embodiment of this invention. The device or assembly 10 is seen to comprise a horizontally elongated, rigid inverted, U-shaped frame or carriage 14 that includes a first vertical depending end bracket 16, and a second depending vertical bracket 18. A horizontal, longitudinally elongated chain saw guide bar 20 is secured to and extends between the end brackets 16, 18, and is longer than the distance therebetween. This provides a first end portion 22 of the guide bar 20 which extends beyond the first end bracket 16 for connection to the power end of the frame 24 of a portable chain saw S, whose motor operates the chain saw 26 that is trained around the second end portion 23 of the guide bar 20 in a groove 28 formed therein. As is seen in the drawings,

the second end portion 23 of the guide bar 20 extends outwardly beyond the second bracket 18.

The first end bracket 16 comprises a horizontally and transversely elongated crossbar 30 which is in register within spaced and substantially parallel relation, an opposed and similar crossbar 32 of the second end bracket 18. Laterally spaced horizontal, parallel leading and trailing rollers 36, 34, respectively, and a middle roller 38, extend between and are journaled at their opposed ends on the bars 30 and 32. As shown in FIGURE 4, a preferable method of so journaling the rollers is by means of shafts 35 which extend through bores 37 formed in the rollers, to provide free rotation of the rollers, with anti-friction bearings 39 seated in the ends of the bores and circumposed on the shafts and bearing outwardly against enlarged split ring bearing retainers 40 mounted on the shafts 35. The other terminal ends of the shafts 35 are formed with external threads 42 which extend through holes 44 formed in and spaced longitudinally along the bars 30 and 32, the shafts 35 being retained in place on the bars 30, 32 by means of nuts 46. As is seen in the several figures of the drawings, the rollers 34, 36 and 38 are coplanar, and the rollers 34 and 36 are spaced from each other a distance greater than the spacing between the rollers 36 and 38. By means to be described below, the guide bar 20 and the saw chain 26 are suspended below and between the rollers 34, 38.

Fixed to and upstanding from the guide bar 20 and connected to the crossbars 30, 32 at locations spaced approximately midway between the rollers 38 and 34 are first and second standards 46 and 48, respectively, the crossbars 30 and 32 being spaced above the guide bar 20, so as to space the cutting plane of the saw chain 26 below the rollers 34, 36 and 38. The standards 46, 48 are substantially flat rectangular bars that extend upwardly and non-rotatably through slots 50 formed, as is indicated at 52, in the crossbars 30, 32. The crossbars 30, 32 have severally thereon longitudinally, outwardly projecting lugs 54 and 56 that are provided with threaded vertical bores 58 through which are downwardly threaded vertical first and second adjusting and locking screws 62 and 64, respectively.

The adjusting screws 62, 64 are suitably journaled in journal brackets 66 and 68 secured to, as indicated at 69, the upper ends of associated standards 46 and 48, against endwise movements of the screws, and the screws 62, 64 have fixedly secured thereto, for rotation therewith, the hand-operated wheels 70 and 72, respectively, the wheels being disposed above the brackets.

A heavy, rigid, longitudinally extending horizontal tie bar or spreader 74 extends between and is suitably fixed at its ends to the upper ends of the standards, as to the brackets 66 and 68. The second standard 48 has a fixed longitudinal foot 76 on its lower end, which is fixed upon the related end of the guide bar 20, and a longitudinal handle 78 is secured on and extends above and longitudinally outwardly from the foot 76.

Fixed on the underside of the guide bar 20 in line with the lower end of the first standard 46 is a bracket 79 having on its lower end a horizontal transverse foot bar 80 which is spaced below the level of the chain saw and the guide bar 20, the foot bar 80 having leading and trailing ends 84 and 82, respectively. Supportable and fixedly journaled on the trailing end 82 of the foot bar 80 is a fixed upstanding guide roller shaft 86 which is disposed to the rear of and proximate the trailing roller 34. Pivoted on the leading end of the foot bar 80, at a location between the leading roller 36 and the middle roller 38, is a swing arm 88 having a fork 89 that receives the bar 80 between its arms 90, as shown in FIGURE 2, and has a line of holes 92 spaced therealong. The holes 92 selectively receive a pivot bolt 94 which also extends through the foot bar 80. The fork arm 90 is joined by an arm 96 having a free end 98, through which a leading upstanding thrust roller shaft 100 is journaled.

The thrust roller shafts 86 and 100 have in common downwardly tapering rounded roller heads 102, 104 on their lower ends below the foot bar 80 and the adjustable arm 96, respectively, and extend laterally beyond each for rolling engagement with the related side of a reclining log L to be longitudinally sawed, at a level below the plane of the saw chain 26 and guide bar 20; the leading roller head 104 being located longitudinally inwardly of the end bracket 16 and longitudinally inwardly of the trailing thrust roller head 102. As a result, the engagement of the roller heads 102, 104 with the side of the log L positions the device diagonally across the log, with the leading roller head 104 and the trailing roller head 102 nearly always remaining in contact with the log, as shown in FIGURE 7, with benefits hereinafter described, by the fact of their being urged toward the long side of the travel toward the thrust roller head 104 of the forward flight 27 of the saw chain 26. The adjustable arrangement of the leading thrust roller 104 provides a self-actuating feeding action of the saw assembly dependent upon the degree of diagonal angle of the assembly relative to the log L, regulated by the longitudinal setting of the thrust roller assembly 104, so that the operator of the device is relieved to the degree desired and within practical limits of the necessity of physical exertion required to force the saw into the wood.

The first end portion of the chain saw guide bar 20 is suitably bored or slotted, as indicated at 105, to accommodate the head 108 of the portable driving means S, and is secured in a suitable manner thereto.

For planking a reclining log L lying where it was felled, a guide plank P is used in making a preliminary or top cut 110, in order to provide thereunder a flat horizontal supporting surface 112 on the log, for the carriage rollers 36, 38 and 34 to roll upon, and so that the rolling contact with the surface 112 provides automatically for the sawing of a next below cut at an angle parallel or angularly spaced to the surface 112 at a distance predetermined by the adjustments of the adjusting screws 62 and 64 by means of their handwheels 70 and 72, respectively.

The guide plank P rests upon and is secured to the irregular upper surface 114 of the log L, as by means of wedges 116 shown in FIGURE 8, or preferably by means of longitudinal laterally spaced depending angle irons 118, to prevent tilting of the plank around the log, the securing of the plank preferably being by means of nails 120 which are to be pulled out in advance of the device 10, in the manner shown in FIGURE 6. When the preliminary cut 110 has been made and the sawed piece put aside, the carriage rollers 36, 38 and 34 are engaged upon the resultant surface 112 and a new sawing operation performed, so as to make a first full cut below the preliminary cut 110, resulting in a desired plank or board. Subsequent cuts are made in the same manner.

It is to be noted that the thrust roller heads 104 and 102 have tapered lower portions 107 which make conforming and frictionless engagement with the upper part of the side of the log L, in making the preliminary cut an upper cut, and the cylindrical upper portions 105 which maintain contact with mid-height portions of the side of the lower log during intermediate cuts.

For cutting the log on different sides, a preliminary cut is made and the log rolled or rotated to present sides thereof for preliminary cuts. For producing cuts which afford planks having opposed concave-convex or convex-concave sides, the carriage 14, including the tie rod 74, is warped by changing the positions of the nuts 46 on the carriage roller shafts 35 so as to spread or contract the lower ends of the frame end members 16 and 18 away or toward each other, and in so moving, cause the saw chain guide 20 to bow or warp, and thereby the saw chain 26, so that the saw chain 26 then makes the desired convex or concave cuts.

The benefit and advantage of the thrust roller means,

in conjunction with the above-described arrangement of the carriage roller means, besides the physical ease of holding the device to the work, is that the carriage roller means provides a forwardly planing or grading engagement of the device with the log surface that facilitates its forward travel on the log, and which serves to maintain an accurate cut and equalize and/or correct irregularities in the wood of the log.

Further, in starting a cut, the leading roller 36 and the middle roller 38, being in advance of the flights of the saw chain 26, enables the operator to properly align the saw chain and guide bar before the cut is begun, by riding the rollers 36 and 38 on the level preliminary cut surface 112; and when finishing a cut, the middle roller 38 and the trailing roller 34 remain on the surface 112 until the cut is finished, and so that the cut is accurate and uniform from end-to-end thereof.

The diagonal position of the device 10 relative to the log L is shown in FIGURE 7, and is variable for sawing logs of different densities and widths, for which purpose the leading thrust roller head 104 is pivotally adjustable toward the side of the log L, on its arm 88. The diagonal travel of the device 10 along a log L under pull or push exerted on the handle 78, by one man, or exerted by two men, one on the handle 78 and the other on the end of the carriage 14, and the consequent diagonal cutting relation of the saw chain 26 to the log L, increases the cutting ease and efficiency of the saw chain, and keeps the leading thrust roller head 104 rolling in frictionless, dragless contact with the log side, as pointed out above, while the trailing thrust roller head 102 bears either constantly or intermittently against the log side, during intentional or unintentional yawing of the device 10 relative to the log. In any case, the leading thrust roller head 104 can, by reason of a locked adjustment thereof, serve as a positive limit stop, when engaged with the log side, which prevents the device from approaching too close to right angles to the log, that is, losing the desired diagonal relation to the log, and this, without physical exertion on the part of the operator of the device.

It is to be noted that the drive means for the saw chain is not restricted to a given end of the frame and chain, as the same may be at either end or both ends thereof, if desired.

FIGURES 10 to 20, inclusive, disclose a second embodiment of the invention wherein the chain saw assembly is denoted generally by the reference numeral 200. As in the modification of the invention described immediately above, the assembly or device 200 includes a substantially inverted U-shaped frame comprising a pair of oppositely-disposed, longitudinally spaced and substantially parallel end brackets 202, 204 (see FIGURES 15 and 17). Each of the brackets 202, 204 is of identical construction and comprises a vertically elongated, substantially rectangular L-shaped angle iron having a foot portion 205, 206, respectively, and leg portions 208, 210. To the upper ends of each of the leg portions 208, 210 of the brackets 202, 204 is fixedly secured a crosshead 212, 214, respectively, the crossheads 212, 214 being substantially rectangular in configuration and being essentially bisected by the foot portions 205, 206 to provide laterally-extending flanges 216, 218 and 220, 222, respectively. The flanges 218, 222 are disposed in confronting relationship relative to each other and each is integrally formed with longitudinally-spaced, parallel and depending flanges 224, 226, respectively. A tie bar or rod 230 extends between and is adjustably mounted on the flanges 224, 226, and is adjustably secured thereon by means of nuts 232.

To the undersides of the foot portions 205, 206, is fixedly secured, as by bolts 234, the chain saw guide bar 236, which extends longitudinally beyond the remotely disposed edges of the foot portions 205, 206, as in the first embodiment of this invention, to provide space for mounting the driving motor 5 for the chain saw designated

at 238, and space for connecting the longitudinally-extending handle 240.

As in the preceding embodiment of this invention, crossbars 242, 244 are slidably mounted on the leg portions 208, 210, respectively, of the brackets 202, 204, and the crossbars 242, 244 are provided with outwardly-projecting lugs 246, 248, the latter being internally threaded and disposed below the flanges 216, 220, respectively. Shafts 250, 252, externally threaded, are received within the lugs 246, 248, respectively, and the upper ends there are journaled for rotation within the flanges 216, 220. As is seen in the several figures, the upper ends of the threaded shafts 250, 252 project above the flanges 216, 220 and have fixedly secured thereto manually-manipulative handles 254, 256. Rotation of the handles 254, 256 clockwise and/or counterclockwise will effect the raising and lowering of the crossbars 242, 244 in the manner hereinbefore described. The vertical position of the crossbars 242, 244 relative to the foot portions 205, 206 adjusts the depth of the cut, as previously described, and which will become more evident as the specification progresses.

Reference numeral 258 denotes a horizontally-extending leading roller fixedly secured to the bars 242, 244 adjacent an end thereof, the roller 258 having the same construction as the leading roller of the previous embodiment of this invention, and as is seen in the several drawings, the roller 258 is free to rotate about a shaft 259 having threaded terminal ends which are extended through appropriate apertures formed in the crossbars 242, 244 and secured thereon by means of the adjusting lock nuts 260. Reference numeral 262 designates a trailing roller mounted on and supported by the crossbars 242, 244 adjacent the other ends thereof. Nuts 264 adjustably secure the roller mounting shaft 266 thereon.

Reference numeral 268 indicates a third roller mounted for free rotation on a roller shaft 270, the thermal ends of the latter extending through and projecting beyond the remote sides of the crossbars 242, 244, the roller shaft 270 being received in the crossbars 242, 244 in a vertically-extending, substantially rectangular slot 272 (see FIGURES 12 and 13), the slot 272 appearing in both crossbars. As is seen in FIGURE 12, the roller 268 is rotatably mounted on the shaft 270 through inset end bearings 273 which are held against end thrust by collars 274 which abut against the outer end thereof and are fixedly secured to the shaft 270 by means of set screws 276.

Adjacent the adjacent sides of the crossbars 242, 244 and engaging thereagainst is a second pair of thrust collars 278 which are mounted on the shaft 270 and are fixedly secured thereto for rotation therewith by means of set screws 280. Also fixedly secured to the opposed ends of the shaft 270, and located adjacent the remotely-disposed sides of the crossbars 242, 244 is a substantially hollow cylindrical member 282, 284 from which project handles 286, 288, respectively. As is seen in FIGURE 13, the hollow cylindrical members 282, 284 are mounted eccentrically on the shaft 270 and are secured thereto by means of set screws 290. Fixedly secured to the crossbars 242, 244 are identical lock plates 292, 294 held in place thereon by means of bolts 296 and nuts 298, the plates being disposed immediately above each of the cylindrical members 282, 284 and are adapted to be engaged by the high sides thereof when the handles 286, 288 are rotated in a counterclockwise direction, reference being made to FIGURE 13 of the drawings. In this position, the roller 284 is held in its locked-down condition, but rotation of the handles 286, 288 into their positions shown in FIGURES 12 and 13 releases the roller shaft 270 so that the same may be free to move vertically in the opening or aperture 272 to serve a purpose to be described.

Projecting laterally from each of the crossbars 242, 244 (see FIGURES 12 and 13) is a stop pin 300 which is so

arranged and positioned as to limit the clockwise movement of the handles 286, 288 in a clockwise direction.

Fixedly secured to the underside of the guide bar 236 is a plate 302 having a basically rectangular configuration. The plate 302 is provided with a plurality of transversely-extending apertures or openings 304 having an arcuate configuration, the openings or apertures 304 being adapted to receive therethrough bolts 306 which extend through the guide bar 236 (see FIGURE 20). The plate 302 has integrally formed therewith a downwardly-dependent arm 308 which is integrally connected with a bar 310 having an elongated, substantially rectangular configuration.

The bar 310, adjacent each end thereof, supports shafts indicated at 312 which extend normally thereto above and below thereof. As in the previous embodiment of this invention, rollers 314 are mounted for rotation about the shaft 312 on that end thereof which projects above the bar 310. In a similar manner, rollers 316 are mounted for free rotation about the shaft 312 on that portion thereof which extends below the bar 310.

The rollers 316 are formed with threads 318 which may be of either right or left-hand threading, depending upon whether the cut is to be made from right to left, as illustrated in FIGURE 14, or left to right, as illustrated in FIGURE 16. The threads 318 are adapted to engage and move along the bark of the log to be sawed, and the threading of the rollers 316 is such as to constantly tend to pull the chain saw 238 downwardly as the cut progresses to resist displacement of the log saw assembly until the threaded portions of the rollers 316 pass the maximum diameter of the log being sawed.

Also subtended from the bar 310 are a pair of intermediate rollers 319 which are adapted to also engage the exterior side of the log being sawed.

It will be observed that the rollers 314 have substantially the same diameters, and that this diameter is carried over into the rollers 316 adjacent the upper ends thereof. The rollers 316, on the threaded portions 318 thereof, taper downwardly.

The arrangement and disposition of the bar 310 is such that one of the rollers 314 is disposed between the leading roller 258 and the center or intermediate roller 268, while the roller 314 always occupies the position behind the trailing roller 262.

The arcuate slots or openings 304, taken together with the bolts 306, provide means whereby the plate 302, and consequently the bar 310, may be pivotally adjusted to assume, for example, either the full-line position shown in FIGURE 19, or the dotted-line position also indicated therein.

It will be recalled that in the first embodiment of this invention, the three rollers 34, 36 and 38 are rigidly fixed in the coplanar position with the chain saw bar. It has been found that with this rigid construction irregularities, in the log being cut, tended to be traced by the rollers and consequently, the chain saw bar. This is due to the fact that the intermediate roller 38 acts as a fulcrum for the leading roller 36 and the trailing roller 34. Now, after extensive use of this device in the practice of sawing lumber, it was found that if the intermediate roller could be released so as to "float" and be inoperative after the three rollers were engaged with the work, a grading or levelling action tending to continually eliminate the irregularities in the wood occurs. This is effected due to the fact that the cutting side of the chain saw bar is disposed approximately one-half way between the leading and trailing rollers, 258, 262 respectively.

The operation of this second embodiment of the invention is essentially the same as that described in connection with the first embodiment.

In operation, and upon starting the cut, the roller 268 is locked down by the handle means 286, 288 so that all rollers are coplanar. With all three of the rollers engaging the work, the handles 286, 288 are rotated to permit

the roller 268 to float free in the slots 272. Just before the leading roller 258 leaves the work, the roller 268 is again locked down in coplanar position to insure proper alignment upon leaving the cut.

The guide roller shaft 86 and the thrust roller shaft 100 and their corresponding rollers 314, all of which extend above the chain saw guide members, are adapted for use when sawing below the greatest diameter of a log and for support when sawing timbers of a thickness that would extend substantially above the chain saw guide bar so as to afford a steadier support. The provision of these members is most important since if they were not provided, the end brackets would drag against the log when sawing below the greatest diameter thereof.

It is obvious, of course, that the instant device could be equipped with a plurality of intermediate rollers 268 which would function in exactly the same manner.

Having described and illustrated two embodiments of this invention, it will be understood that the same are offered merely by way of example, and that the instant invention is to be limited only by the scope of the appended claims.

What is claimed is:

1. A portable log saw assembly comprising a carriage to extend across a reclining log, means mounted on the carriage to bear movably upon the log, a saw guide bar mounted on the carriage and spaced below said means, a saw chain trained around said guide bar, said carriage having a first and a second end and said chain having a leading flight working toward said first end, a saw chain driving means mounted on said carriage and operably connected to said saw chain, lateral thrust means mounted on the carriage at said first end having thrust head means located on the carriage at said first end and having thrust head means located below the level of the saw chain and guide bar for engaging the side of a log in thrust opposition to the action of the leading flight of said saw chain, said first mentioned means comprising a leading roller, a middle roller, and a trailing roller, said rollers being in the same horizontal plane, with said saw guide bar and said saw chain located between the middle roller and the trailing roller.

2. A portable log saw assembly comprising a carriage adapted for extension across a reclining log and travel along the length of the log, roller means on axes spaced apart in the direction of travel of the said carriage and mounted on the carriage in a plane to roll upon the log, a saw guide bar mounted on the carriage and spaced below and parallel to said plane of roller means, a saw chain trained around said guide bar, said carriage having a first end and a second end and said chain having a leading flight working toward said first end, said saw chain having driving means fixedly secured to said carriage in driving connection with said saw chain, lateral thrust means mounted on said carriage at said first end and having thrust head means located below the level of said saw chain and said guide bar for engaging the side of a log in thrust opposition to the action of said leading flight of said saw chain, said thrust means being pivotally mounted on said carriage, and means for adjusting and locking said roller means in vertically-adjusted relations above said guide bar and chain.

3. A portable log saw assembly comprising a carriage to extend across a reclining log, a plurality of horizontal laterally spaced roller means mounted on said carriage to roll upon said log, a saw guide bar mounted on said carriage and spaced below parallel to said roller means, a saw chain trained around said guide bar, said carriage having a first end and a second end and said chain having a leading flight working toward said first end, saw chain driving means mounted on said carriage and operably connected to said saw chain, lateral thrust means mounted on said carriage at said first end and including thrust head means located below the level of said saw chain and guide bar for engaging a side of said log, means for ad-

justing and locking the roller means in vertically-adjusted relations above said guide bar and chain, said carriage roller means including a leading roller, at least one middle roller, and a trailing roller, said rollers being in the same horizontal plane, with said guide bar and said chain located between at least one said middle roller and said trailing roller.

4. A portable log saw assembly comprising a carriage to extend across a reclining log and travel along the length of the log, a plurality of horizontal roller means on axes spaced apart in the direction of travel of said carriage and mounted on the carriage in a plane to roll upon said log, a saw guide bar mounted on said carriage and spaced below and parallel to said plane of said roller means, a saw chain trained around said guide bar, said carriage having a first end and a second end and said chain having a leading flight working toward said first end, saw chain driving means mounted on said carriage and operably connected to said saw chain, lateral thrust means mounted on said carriage at said first end, said thrust means including means located above and below the level of said saw chain and guide bar for engaging a side of said log, said thrust means comprising vertical shafts mounted on said carriage at said first end thereof, and said thrust means including rollers journaled on said vertical shafts.

5. A portable log saw assembly comprising a carriage to extend across a reclining log and travel along the length of the log, a plurality of horizontal roller means on axes spaced apart in the direction of travel of said carriage and mounted on the carriage in a plane to roll upon said log, a saw guide bar mounted on said carriage and spaced below and parallel to said plane of said roller means, a saw chain trained around said guide bar, said carriage having a first end and a second end and said chain having a leading flight working toward said first end, saw chain driving means mounted on said carriage and operably connected to said saw chain, lateral thrust means mounted on said carriage at said first end and having thrust means located below the level of said saw chain and said guide bar for engaging a side of said log, said thrust means comprising vertical shafts mounted on said carriage at the first end thereof and said thrust means including rollers journaled on said vertical shafts of which one of said vertical shafts is a trailing thrust shaft fixedly mounted on said carriage behind said carriage roller means.

6. A portable log saw assembly comprising a carriage to extend across a reclining log and travel along the length of the log, a plurality of horizontal roller means on axes spaced apart in the direction of travel of said carriage and mounted on the carriage in a plane to roll upon said log, a saw guide bar mounted on the carriage and spaced below and parallel to said plane of said roller means, a saw chain trained around said guide bar, said carriage having a first end and a second end and said chain having a leading flight working toward said first end, saw chain driving means mounted on said carriage and operably connected to said saw chain, and lateral thrust means mounted on said carriage at said first end, said lateral thrust means including means located above and below the level of said saw chain and guide bar for engaging a side of said log, said thrust means comprising vertical shafts mounted on the carriage at said first end thereof, said thrust means comprising rollers journaled on said vertical shafts, one of said vertical shafts being a trailing shaft fixedly mounted on said carriage behind the carriage roller means, another of said vertical shafts being fixedly mounted on said carriage at a location forwardly and longitudinally-inwardly of said trailing thrust shaft for adjustment toward and away from said first end of said carriage and relative to said side of said log.

7. A portable log saw assembly comprising a carriage to extend across a reclining log, plural horizontal roller means mounted on said carriage to roll upon said log, a saw guide bar mounted on the carriage and spaced below said roller means, a saw chain trained around said guide

bar, said carriage having a first end and a second end and said chain having a leading flight working toward said first end, saw chain driving means mounted on said carriage and operably connected to said saw chain, and lateral thrust means mounted on said carriage at said first end having thrust head means located below the level of said saw chain and said guide bar for engaging a side of said log in thrust opposition to the action of the leading flight of said saw chain, and screw means for adjusting and locking the roller means in vertically-adjusted relations above said guide bar and chain, said carriage roller means comprising a leading roller, a middle roller, and a trailing roller, said rollers being in the same horizontal plane, with the said guide bar and the chain located between the middle roller and the trailing roller, roller shafts extending between the first and second ends of the carriage upon which the rollers are severally journaled, said roller shafts having ends secured to the carriage ends for longitudinal adjustment of the spacing of portions of the carriage ends in the region of the saw guide bar for warping of the saw guide bar.

8. A portable log saw assembly comprising an inverted substantially U-shaped frame including a tie rod from the ends of which depend leg portions, an elongated bar slidably mounted on each of said leg portions in laterally-spaced and confronting relation, a plurality of rollers mounted and supported for rotation on said bars in longitudinally-spaced relation, said rollers including leading and trailing rollers and at least one roller disposed therebetween, said rollers being normally coplanar, means on said bars to release said one roller for movement out of said coplanar relationship, a saw guide bar mounted on said frame below said rollers, a saw chain trained around said guide bar, and means for driving said saw chain.

9. A portable log saw assembly comprising an inverted substantially U-shaped frame including a tie rod from the ends of which depend leg portions, an elongated bar slidably mounted on each of said leg portions in laterally-spaced and confronting relation relative to each other, a plurality of rollers mounted and supported for rotation on said bars in longitudinally-spaced relation relative to each other, said rollers including leading and trailing rollers and at least one roller disposed therebetween, said rollers being normally coplanar, means on said bars to release said one roller for movement in and out of said coplanar relationship, a saw guide bar mounted on said frame below said trailing roller and said intermediate roller, a saw chain trained around said guide bar, means for driving said saw chain, a plate fixedly secured to one end of said saw guide bar, said plate having fixedly secured thereto a support bar, said support bar having an elongated substantially rectangular configuration, a roller mounted for rotation on each end, respectively, of said support bar, one of said rollers projecting vertically between said leading roller and said intermediate roller, the other of said last-named rollers projecting upwardly at right angles with respect to the trailing roller and being disposed rearwardly thereof, and means cooperating with said plate whereby said rollers mounted on said second bar may be adjusted angularly with respect to the longitudinal axes of said leading, said trailing, and said intermediate rollers.

10. A portable log saw assembly comprising an inverted substantially U-shaped frame including a tie rod from the ends of which depend the leg portions of a pair of angle irons having integrally formed foot portions at the lower ends thereof, an elongated substantially rectangular bar slidably mounted on each of said leg portions in laterally-spaced and confronting relation, a plurality of shafts mounted on said bars in longitudinally-spaced and substantially parallel relation relative to one another, a plurality of rollers mounted on said shafts, respectively, for free rotation relative thereto, said rollers including a leading roller, a trailing roller, at least one roller being disposed intermediate said leading and trailing rollers, a

vertically-extending opening formed in each of said bars and disposed in confronting relation relative to one another, said shaft for said intermediate roller having its terminal ends received within said openings and being vertically movable therein, eccentric means secured to each end of said last-named shaft to effect a locked-down position of said last-named shaft and operable to effect the release thereof, a saw guide bar fixedly secured to said foot portions of said angle irons, said saw guide bar being disposed intermediate said trailing roller and said one roller, a saw chain trained around said guide bar, and means for driving said saw chain.

11. A portable log saw assembly comprising an inverted substantially U-shaped frame including a tie rod from the ends of which depend the leg portions of a pair of angle irons having foot portions at the lower ends thereof, an elongated substantially rectangular bar slidably mounted on each of said leg portions in laterally-spaced and confronting relation relative to each other, a plurality of rollers mounted and supported for rotation on said bars in longitudinally-spaced relation relative to each other, said rollers including leading and trailing rollers and at least one roller disposed therebetween, said rollers being normally coplanar, means on said bars and said rollers to release said one roller for movement out of said coplanar relationship, a saw guide bar fixedly secured to said foot portions and extending therebetween, said saw guide bar being disposed below said rollers, a chain trained around said guide bar, means for driving said saw chain, a plate fixedly secured to one end of said saw guide bar, a support bar fixedly secured to said plate below said saw guide bar, said support bar having a substantially rectangular configuration, a shaft fixedly secured to each end of said support bar and projecting on each side thereof in a vertical direction, one of said shafts extending between said leading roller and said intermediate roller and the other of said shafts being disposed rearwardly of said trailing roller, a roller mounted on each of said shafts and projecting upwardly between said leading and one roller and rearwardly of said trailing roller, a roller mounted on each of the depending ends of said last-named shafts, said last-named rollers tapering from top to bottom and being provided with external threads the engagement of which with a log will cause said assembly to move inwardly toward said log, and means for changing the angularity of said second bar with respect to the longitudinal axis of any of the leading, trailing, or said one roller.

12. A log saw assembly as defined in claim 11, and a plurality of rollers mounted on said support bar intermediate the ends thereof.

13. In a log saw assembly as defined in claim 12, wherein the diameter of said last-named rollers is substantially the same as said rollers mounted on said vertically-extending shafts.

14. A portable log saw assembly comprising a carriage for extension across a felled log, guide means mounted in a plane on said carriage to bear on said log as said carriage is moved longitudinally thereof, said guide means including a leading roller, a middle roller, and a trailing roller, means on said carriage to effect the connection of a chain saw therewith in a plane below and parallel to the plane of said guide rollers, thrust means extending below said chain saw plane for engagement with said log as said chain saw is operated and said carriage is moved longitudinally of said log, and said thrust means including a roller having a downwardly-tapering portion, said tapering portion having bark-engaging threads to resist vertical displacement of said portable log saw assembly during a sawing operation.

15. A portable log saw assembly comprising an inverted substantially U-shaped frame including a tie rod from the ends of which depend the leg portions of a pair of angle irons having foot portions at the lower ends thereof, an elongated substantially rectangular bar slidably

mounted on each of said leg portions in laterally-spaced and confronting relation relative to each other, a plurality of rollers mounted and supported for rotation on said bars in longitudinally-spaced relation relative to each other, said rollers including leading and trailing rollers and at least one roller disposed therebetween, said rollers being normally coplanar, means on said bars and said rollers to release said one roller for movement out of said coplanar relationship, said foot portions providing means for connecting a saw guide bar to said assembly, said saw guide bar being normally disposed below said rollers, a bar fixedly secured to one of said foot portions below said saw guide bar, a shaft fixedly secured to each end of said last-named bar and projecting on each side thereof in a vertical direction, one of said shafts extending between said leading roller and said intermediate roller and the other of said shafts being disposed rearwardly of said trailing roller, a roller mounted on each of said last-named shafts and projecting upwardly between said leading and one roller and rearwardly of said trailing roller, a roller mounted on each of the depending ends of said last-named shafts, said last-named roller tapering from top to bottom and being provided with external threads the engagement of which with the log causing said assembly to move inwardly toward said log, and means for changing the angularity of said last-named bar with respect to the longitudinal axis of any of the leading, trailing, or said one roller.

16. A portable log saw assembly as defined in claim 15, and means on said frame for vertically adjusting said first rollers longitudinally of said leg portions.

17. A portable log saw assembly comprising a carriage adapted to extend across a reclining log, a plurality of guide means mounted on said carriage in a plane to bear movably upon said log, said plural guide means including a leading guide means, a middle guide means, and a trailing guide means, means on said carriage to effect the connection of a chain saw guide bar therewith for spacing below and parallel to the plane of said plural guide means between said middle and trailing guide means, a saw chain trained around said guide bar, said carriage having a first end and a second end, and said chain having a leading flight working toward said first end, saw chain driving means mounted on said guide bar and carriage and operably connected to said saw chain, and thrust means for engagement with said log as said saw chain is driven and said carriage is moved along said log.

18. A portable log saw assembly comprising a carriage to extend across a reclining log, plural horizontal roller means mounted on the carriage to roll upon the log, a saw guide bar mounted on the carriage and spaced below said roller means, a saw chain trained around the guide bar, said carriage having a first end and a second end and said chain having a leading flight working toward said first end, saw chain driving means mounted on the carriage and operatively connected to the saw chain, and lateral thrust means mounted on the carriage at said first end having thrust head means located below the level of the saw chain and guide bar for engaging the side of a log in thrust opposition to the action of the leading flight of the saw chain, and screw means for adjusting and locking the roller means in vertically-adjusted relations above the said guide bar and chain, said carriage roller means comprising a leading roller, a middle roller, and a trailing roller, said rollers being in the same horizontal plane, with the said guide bar and the chain located between the middle roller and the trailing roller, roller shafts extending between the first and second ends of the carriage upon which the rollers are severally journaled, said roller shafts having ends secured to the carriage ends for longitudinal adjustment of the spacing of portions of the carriage ends in the region of the saw guide bar for warping the saw guide bar, said first and second carriage ends comprising vertical end brackets, a rigid tie bar extending between and fixed to the end brackets at their

13

upper ends, the roller shafts having their ends severally traversing the brackets at the lower ends thereof.

19. A portable log saw assembly comprising a carriage to extend across a reclining log, plural horizontal roller means mounted on the carriage to roll upon the log, a saw guide bar mounted on the carriage and spaced below said roller means, a saw chain trained around the guide bar, said carriage having a first end and a second end and said chain having a leading flight working toward said first end, saw chain driving means mounted on the carriage and operatively connected to the saw chain, and lateral thrust means mounted on the carriage at said first end having thrust head means located below the level of the saw chain and guide bar for engaging the side of a log in thrust opposition to the action of the leading flight of the saw chain, and screw means for adjusting and locking the roller means in vertically-adjusted relations above the said guide bar and chain, said carriage roller means comprising a leading roller, a middle roller, and a trailing roller, said rollers being in the same horizontal plane, with the said guide bar and the chain located between the middle roller and the trailing roller, roller shafts extending between the first and second ends of the carriage upon which the rollers are severally journaled, said roller shafts having ends secured to the carriage ends for longitudinal adjustment of the spacing of portions of the carriage ends in the region of the saw guide bar for warping the saw guide bar, said first and second carriage ends comprising vertical end brackets, a rigid tie bar ex-

14

tending between and fixed to the end brackets at their upper ends, the roller shafts having their ends severally traversing the brackets at the lower ends thereof, said end brackets comprising standards having upper ends to which the tie bar is fixed and lower ends to which the saw guide bar is fixed, and cross bars slidably confined on the standards and through which the roller shaft ends are engaged, said adjusting screw means being vertical screws rotatably fixed on the standards at the upper end of the standards, said cross bars having threaded lugs through which the screws are threaded.

References Cited by the Examiner

UNITED STATES PATENTS

1,652,756	12/1927	Bruce.	
2,813,556	11/1957	Woodworth.	
3,134,409	5/1964	Hayden	----- 143—32

FOREIGN PATENTS

941,406	7/1948	France.
727,488	11/1942	Germany.

OTHER REFERENCES

Special Attachment for Plank Making and Bridge Timbers, page 3, Timberhog Chain Saw Catalogue, 1938.

WILLIAM W. DYER, JR., *Primary Examiner*.

MORRIS M. FRITZ, DONALD R. SCHRAN, *Examiners*.