

(No Model.)

B. F. LEWIS.
SHAFT SHACKLE.

No. 314,694.

Patented Mar. 31, 1885.

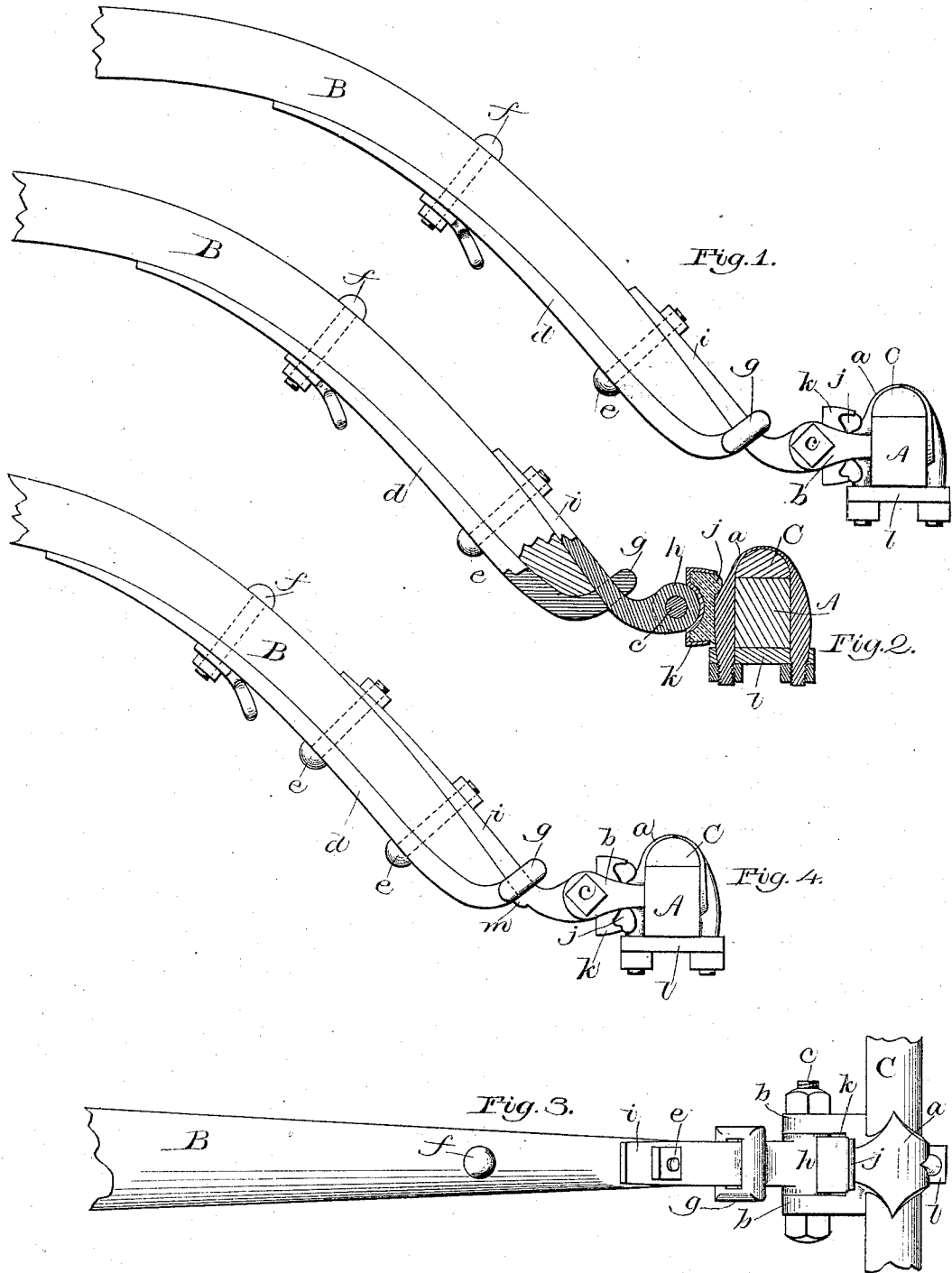

Witnesses
a. c. Crane
A. G. Porter.

Inventor
Benjamin F. Lewis
per Porter & Hutchinson
Atty

UNITED STATES PATENT OFFICE.

BENJAMIN F. LEWIS, OF AMESBURY, MASSACHUSETTS.

SHAFT-SHACKLE.

SPECIFICATION forming part of Letters Patent No. 314,694, dated March 31, 1885.

Application filed October 13, 1884. (No model.)

To all whom it may concern:

Be it known that I, BENJAMIN F. LEWIS, of Amesbury, in the county of Essex and State of Massachusetts, have invented a new and useful Improvement in Shifting Shaft-Shackles, which will, in connection with the accompanying drawings, be hereinafter fully described, and specifically defined in the appended claim.

This invention has for its object the production of a shaft-shackle for vehicles which facilitates the disconnecting of the shafts from the vehicle without disturbance of the pivot-bolt of the shackle or the liberation of the compressed anti-rattler cushion; and it will, in connection with the drawings, be hereinafter fully described and claimed.

In said drawings, Figure 1 is an elevation showing my invention in connection with the shaft, axle, and shackle. Fig. 2 is a view similar to Fig. 1, except that the axle, the shackle, and the lower portion of the shaft are shown in vertical section taken on a line passing centrally through the shaft. Fig. 3 is a top or plan view of Fig. 1; and Fig. 4 is a view like Fig. 1, but showing certain modifications.

In said views, A represents the axle, B is the shaft, and C the wooden stock, all of usual construction, as is the shackle *a*, which is formed to inclose the axle and stock, and to receive and be secured in place by yoke *l*, and is formed with usual perforated ears, *b*, which receive the pivot-bolt *e*, on which the shaft-eye *h* is secured between ears *b*, in the well-known manner.

Instead of forming the under iron, *d*, of the shafts with eye *h* at its rear extremity adapted to receive pivot-bolt *e*, I form thereon the eye *g*, having a rectangular hole or passage, as shown, to receive the strap *i*, which is inte-

gral with and extends from eye *h*, and is arranged upon the upper side of shaft B, to which it is secured by said eye *g* and the screw-bolt *e*, which passes through iron *d*, the shaft, and strap *i*, as shown.

Instead of securing the strap *i* to the shaft by one bolt *e*, as shown in Figs 1, 2, 3, two of said bolts may be employed, as shown in Fig. 4; and, if desired, a shoulder, *m*, may be formed on strap *i* and arranged to bear against eye *g*, as shown in said Fig. 4. By thus forming the iron *d* with an eye adapted to receive strap *i*, and forming said strap *i* integral with the pivotal eye *h* and securing it upon the upper side of the shaft by means of eye *g* and bolt *e*, the end of the shaft is secured between straps *d* and *i*; and when it is desired to detach the shafts from the carriage, either to replace them with a pole or for other reasons, it is only necessary to remove the screw-nuts from bolts *e* and "drift" the bolts below straps *i*, when the shafts may be instantly detached from the vehicle, leaving straps *i* with their pivotal eyes *h* still mounted upon bolts *e*, and with the pressure of buffers *j k* still exerted thereon; and the shafts or a pole may be attached to the vehicle as readily as the shafts are detached therefrom.

I claim as my invention—

The strap *i*, formed to be attached to the part of the shackle secured to the axle and to extend along the top of shaft B, in combination with strap *d*, formed with eye *g*, to receive strap *i*, and curved upward a distance sufficient to admit the shaft between said straps, substantially as specified.

BENJAMIN F. LEWIS.

Witnesses:

T. W. PORTER,
EUGÈNE HUMPHREY.