



- (51) International Patent Classification:
E05F 17/00 (2006.01) B64C 1/14 (2006.01)
E05D 15/58 (2006.01)
- (21) International Application Number: PCT/US2015/039598
- (22) International Filing Date: 8 July 2015 (08.07.2015)
- (25) Filing Language: English
- (26) Publication Language: English
- (30) Priority Data:
62/023,530 11 July 2014 (11.07.2014) US
14/754,620 29 June 2015 (29.06.2015) US
- (71) Applicant: B/E AEROSPACE, INC. [US/US]; 1400 Corporate Center Way, Wellington, Florida 33414 (US).
- (72) Inventors: CHRISTENSON, Justin C.; 13105 27th Pl.W, Everett, Washington 98204 (US). LOAR, Graydon E.; 7000 Cleopatra Pl.NW, Seattle, Washington 98117 (US).
- (74) Agent: JAMES, Paul W.; Fulwider Patton LLP, 6060 Center Drive, Tenth Floor, Los Angeles, California 90045 (US).
- (81) Designated States (unless otherwise indicated, for every kind of national protection available): AE, AG, AL, AM, AO, AT, AU, AZ, BA, BB, BG, BH, BN, BR, BW, BY, BZ, CA, CH, CL, CN, CO, CR, CU, CZ, DE, DK, DM, DO, DZ, EC, EE, EG, ES, FI, GB, GD, GE, GH, GM, GT, HN, HR, HU, ID, IL, IN, IR, IS, JP, KE, KG, KN, KP, KR, KZ, LA, LC, LK, LR, LS, LU, LY, MA, MD, ME, MG, MK, MN, MW, MX, MY, MZ, NA, NG, NI, NO, NZ, OM, PA, PE, PG, PH, PL, PT, QA, RO, RS, RU, RW, SA, SC, SD, SE, SG, SK, SL, SM, ST, SV, SY, TH, TJ, TM, TN, TR, TT, TZ, UA, UG, US, UZ, VC, VN, ZA, ZM, ZW.

[Continued on next page]

(54) Title: TELESCOPING AIRCRAFT PANEL DOOR

FIG. 1

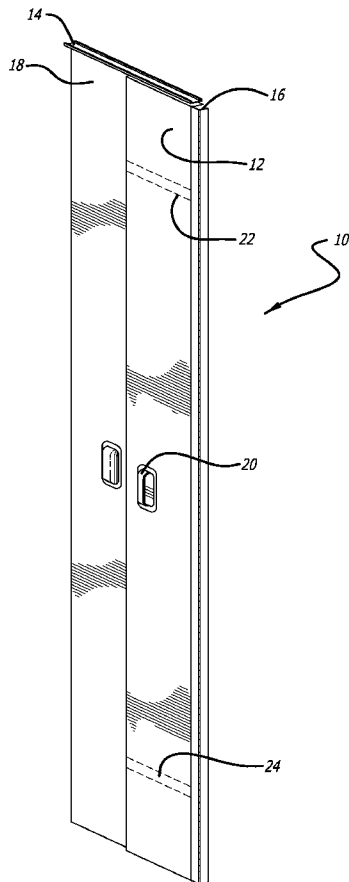

(57) Abstract: A telescoping aircraft door is disclosed having first and second panels that slide relative to one another to extend and retract as the door closes and opens, respectively. The first panel is hinged to the door frame in a traditional manner, and the second panel is fixed to the door frame by a linkage that limits the arc of the second panel. By selecting the location and length of the linkage, the relative movement of the two panels can be predictably controlled to reduce the depth of the door when closed and the length of the door when opened.

WO 2016/007663 A1



(84) Designated States (*unless otherwise indicated, for every kind of regional protection available*): ARIPO (BW, GH, GM, KE, LR, LS, MW, MZ, NA, RW, SD, SL, ST, SZ, TZ, UG, ZM, ZW), Eurasian (AM, AZ, BY, KG, KZ, RU, TJ, TM), European (AL, AT, BE, BG, CH, CY, CZ, DE, DK, EE, ES, FI, FR, GB, GR, HR, HU, IE, IS, IT, LT, LU, LV, MC, MK, MT, NL, NO, PL, PT, RO, RS, SE,

SI, SK, SM, TR), OAPI (BF, BJ, CF, CG, CI, CM, GA, GN, GQ, GW, KM, ML, MR, NE, SN, TD, TG).

Published:

— *with international search report (Art. 21(3))*

TELESCOPING AIRCRAFT PANEL DOOR

CROSS-REFERENCES TO RELATED APPLICATIONS

This application claims priority from U.S. Application No. 62/023,530, filed July 11, 2014, and from U.S. Application No. 14/754,620, filed June 29, 2015, the content of which are incorporated by reference in their entireties.

5

BACKGROUND

The interior of a commercial aircraft typically includes several compartments, such as crew changing quarters, lavatories, galleys, and the like. In each case, ingress and egress of these compartments are typically through a door or panel that walls off the compartment when in use. Doors of this type include both sliding doors and swinging doors. Each of these types of doors have inherent drawbacks. Namely, swinging or hinged doors occupy a large amount of cross-aisle space when the door is open and the design of the aircraft must account for the free space needed to accommodate the arc of the door as it transitions open. Conversely, sliding doors occupy twice the depth space to achieve the same closure area. Both of these shortcomings add unnecessary weight and/or occupy space that could be used for better purposes. Thus, there is a need for an improved door for use in an aircraft that overcomes the shortcomings of the prior art.

10

15

SUMMARY OF THE INVENTION

The present invention is directed to a two panel door having a first panel hinged to the door frame and a second panel coupled to the frame by a linkage that includes a rotating arm. The rotating arm reduces the arc traveled by the second panel (and thus the door in general) and results in a door with less width, weight, and covers the same area without unduly monopolizing cross-aisle space. The door when opened is roughly half as wide as when it is closed, allowing for a more narrow aisle or, alternatively, leaving more aisle space available for cross traffic. In narrow aisle aircraft, the use of a bi-fold door can be replaced with the present invention.

20

25

BRIEF DESCRIPTION OF THE DRAWINGS

FIG. 1 is an elevated perspective view of a first embodiment of the present invention;

FIGURES 2A-2E show a sequence of positions of the first and second panels as the door of the present invention transitions from closed to open;

FIG. 3 is an elevated, perspective view of the first and second panels; and

FIG. 4 is a perspective view looking upward at the linkage between the second
5 panel and the door frame.

DETAILED DESCRIPTION OF THE PREFERRED EMBODIMENTS

Figure 1 illustrates a first preferred embodiment of a telescoping door of the present invention in which a door for an aircraft, vessel, or other vehicle is disclosed. The door 10 of the present invention comprises at least two panel, including a first panel 12
10 connected to the door frame 14 via a hinge or set of hinges, such as the piano hinge 16, and a second panel 18 that is slidingly engaged with the first panel 12 and extends therefrom. The first panel 12 is attached to the frame 14 in a pivoting arrangement and a width of the first panel is selected to be sufficient to approximately span one half of the width of the doorway. A handle or release lever 20 is provided in the first panel 12 to
15 assist in opening and closing the door 10. The first panel 12 is also provided with preferably two horizontal grooves or slots 22,24, as set forth more fully below. The operation of the first panel 12 is relatively simply, swinging about its fixed point on the hinge or hinges 16 between on open position and a closed position, where the closed position locates the first panel 12 in the doorway where it occupies approximately one half
20 of the door frame area.

The second panel 18 of the telescoping door 10 is attached to the first panel through a wheel 23 and slot arrangement where the wheels are captured on tracks in the horizontal slots 22,24 or grooves, such that the second panel 18 is carried by the wheels 24
25 to move relative to the first panel 12 in a sliding or telescoping relationship. It should be noted that the wheels 23 of the second panel 18 can be replaced with other structure that allow the second panel 18 to glide or extend outward from the first panel 12 without undue friction or resistance (e.g., drawer slides) and is not limited to any particular mode of sliding/rolling/shifting engagement. If the second panel 18 is sized to be approximately
30 the same width as the first panel 12, when fully extended away from the first panel 12 (in the direction away from the hinged connection on the first panel) the second panel 18 will cooperate with the first panel 12 to completely cover and occlude the door frame 14 in a

reliable manner. That is, the first and second panels 12,18 have a combined width that when fully extended close the doorway when the door 10 is closed by virtue of the full extension of the second panel 18 along and within the horizontal grooves or slots 22,24 of the first panel 12.

5 To extend and retract the second panel 18 from the first panel 12 as discussed above, the second panel 18 is connected along an upper edge 26 to the door frame 14 by a linkage such as a rigid bar 28. The bar 28 is fixed at a first end 30 to the second panel 18 at an inner edge 32 that is closest to the piano hinge 16, and is fixed at a second end 34 in a pivoting connection to the door frame approximately at approximately one quarter of the
10 distance between the sides of the door frame, closest to the side 36 with the hinge that connects the first panel 12 (See Figure 2).

Figure 2 shows a sequence of the two panels 12,18 as the door 10 transitions from fully closed in Figure 2a to fully open in Figure 2e. In the first frame (Figure 2A), the telescoping door 10 is fully closed and lies in the plane of the doorway. The depth (or
15 thickness) of the door 10 is a single panel for the entire door's length except for where the two panels are joined together, creating space on both sides of the door itself. In the second frame (Figure 2B), the door 10 is slightly ajar as it begins to open.

One can see that the first panel 12 is hinged to the door frame 14 and moves in a predictable arc about the hinged connection. However, the second panel 18 is prevented
20 from following the same arc due to the fixed connection of the inner edge 32 with the door frame via the linkage 28. As a result, the second panel 18 is retracted or constrained along the first panel 12 within the horizontal grooves or slots 22,24, and the door "shortens" in length as a result.

In the third frame (Figure 2C), the door 10 is approximately half way open and the
25 second panel 18 is further withdrawn or retracted into the first panel as the door continues to shorten. The fixed connection of the linkage 28 at the second panel 18 pulls the second panel along the first panel 12 such that the combined width (negating overlap) of the first and second panels is effectively halved.

In the fourth frame (Figure 2D), the first panel 12 is opened more than half way,
30 and the second panel 18 has almost completely moved in alignment with the first panel such that the door's width is significantly reduced. Finally, in the last frame, the linkage

28 has retracted the second panel 18 into complete alignment with the first panel 12 such that there is essentially no overlap between the two panels 12,18. The width of the door 10 now coincides with the width of the first panel 12 as the second panel 18 is hidden behind the first panel. When used as a lavatory door, for example, the telescoping door of the present invention when closed extends only approximately half way into the lavatory as compared with a traditional door, yielding greater mobility and comfort to the occupant without any loss of function.

Figure 3 illustrates the first and second panels 12,18 in the closed (extended) position. The horizontal slot 22 in the first panel is shown, and the wheel 23 or other engagement mechanism is shown in shadow that couple the two panels 12,18 together. A pivoting extension 50, such as a coat hook, can be positioned just adjacent the edge of the second panel. When the extension 50 is seated inside the first panel 12, the second panel 18 is free to slide back and forth as shown in Figure 2 as the door transitions from opened to closed. However, with the extension pivoted out of the plane of the first panel 12, the second panel 18 is blocked from sliding across the surface of the first panel 12 by the interference of the extension 50. Thus, a reliable and efficient locking mechanism can be formed using a dual purpose coat hook 50 or the like.

Figure 4 illustrates the linkage 28 between the second panel 18 and the door frame 14. The linkage 28 connects the second panel 18 at a top edge 26 with a pin or other mechanical arrangement that allows for rotation of the linkage 28 about the connection so that the linkage can track the second panel 18 as it rotates around the primary hinge 16. The bar, rod, or other structure that forms the linkage 28 is connected to the door frame 14 or an immediate adjacent location by a similar pivoting coupling that allows for the linkage 28 to swivel at the fixed location. As the door 10 opens, the linkage 28 limits the travel of the second panel 18 from the fixed connection point of the bar, thereby causing the second panel 18 to slide along the horizontal grooves 22, 24 from an extended position to a retracted position as the first panel 12 swings in an arc away from the fixed connection point. In this manner, the length of the door 10 automatically shortens to (roughly) half of its extended length in the open position.

The horizontal grooves or slots 22, 24 on the first panel 12 establish tracks or raceways that permit a smooth rolling or sliding motion across their surfaces, so that the second panel 18 can move easily and freely along the first panel. This is particularly

important where there is only one linkage 28 maneuvering the second panel 18 at the top 26 of the door 10, because friction or sticking of the track will cause issues with torquing or twisting of the panels with a resultant loss of effectiveness.

The result is a two panel door for an aircraft compartment that has a first panel
5 hingedly connected to a door frame, the first panel having a width of approximately half of a door frame to which it is mounted, and a second panel mounted on the first panel for sliding translation thereon, the second panel extending parallel to the first panel in a sliding arrangement. The first panel is coupled to the door frame via a hinge and the second panel is coupled to the door frame via a linkage, the linkage fixing a distance that
10 the second panel can extend from the door frame as the first panel swings about its hinged connection is a circular arc. The two panel door operates such that the ends of the panels 60,32 are adjacent in the closed configuration and the faces 62,64 of the panels 12, 18 are adjacent to each other in the open configuration.

It will be apparent from the foregoing that while particular forms of the
15 invention have been illustrated and described, various modifications can be made without departing from the spirit and scope of the invention. Accordingly, it is not intended that the invention be limited, except as by the appended claims.

I Claim:

1. A two panel door for an aircraft compartment, comprising:
a first panel hingedly connected to a door frame, the first panel having a width of approximately half of a door frame to which it is mounted;
5 a second panel mounted on the first panel for sliding translation thereon, the second panel extending parallel to the first panel in a sliding arrangement;
a linkage for fixing coupling a door frame to the second panel at a distance of approximately one fourth a length of the door frame, the linkage fixing a distance that the second panel can extend from the door frame, the linkage coupled to the door frame and
10 the second panel so as to permit relative pivoting between connected ends;
wherein the two panel door operates such that the ends of the panels are adjacent in the closed configuration and the faces of the panels are adjacent in the open configuration.
2. The two panel door of Claim 1, further comprising an extendable locking mechanism on the first panel to prevent the door from opening when the extendable
15 locking mechanism is in a first position.
3. The two panel door of Claim 2, wherein the extendable locking mechanism is a coat hook.
4. The two panel door of Claim 1, wherein the first panel includes first and second spaced apart horizontal rails and the second panel includes a pair of wheels
20 configured to ride in the rails and support the sliding relationship therebetween.
The two panel door of Claim 1, wherein the first panel is connected to the door frame via a piano hinge.
5. The two panel door of Claim 1, wherein the width of the first panel is approximately equal to a width of the second panel.

25

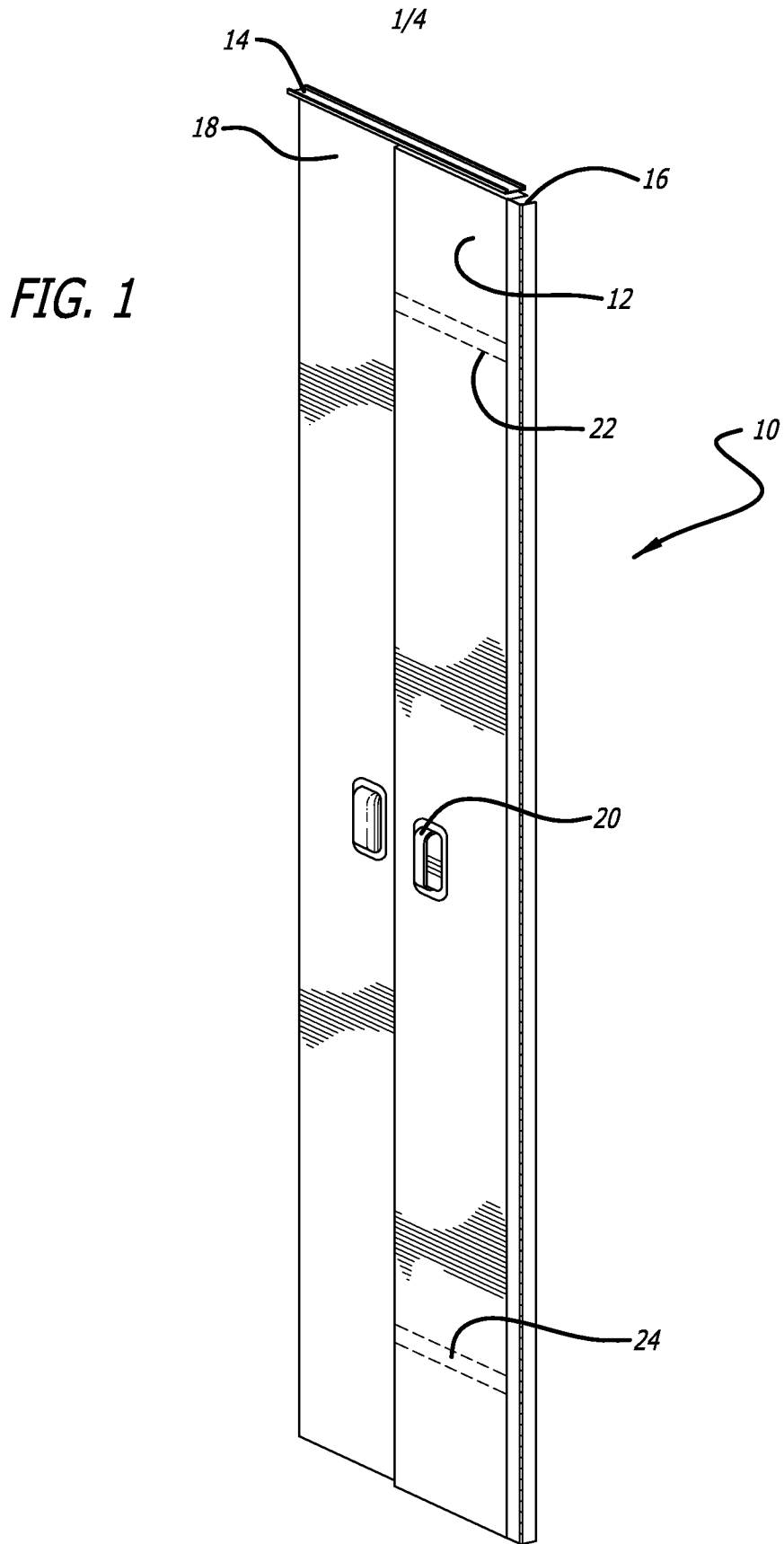

2/4

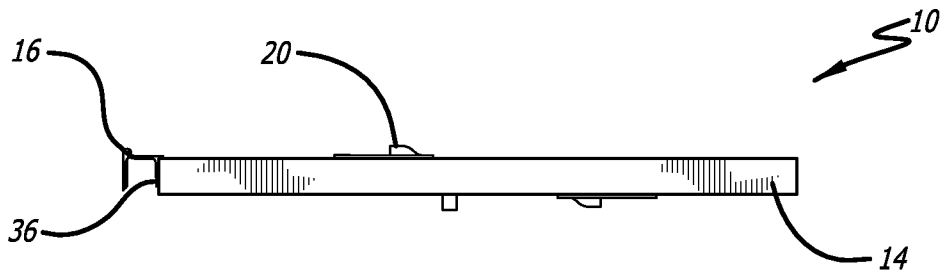

FIG. 2A

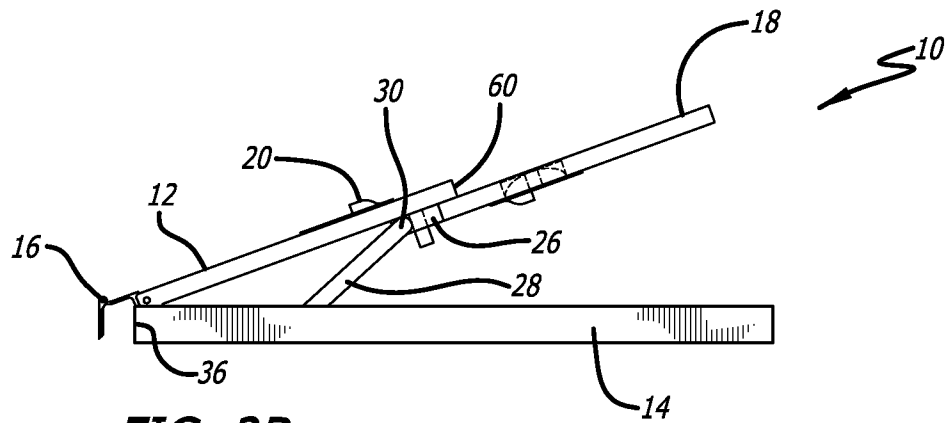

FIG. 2B

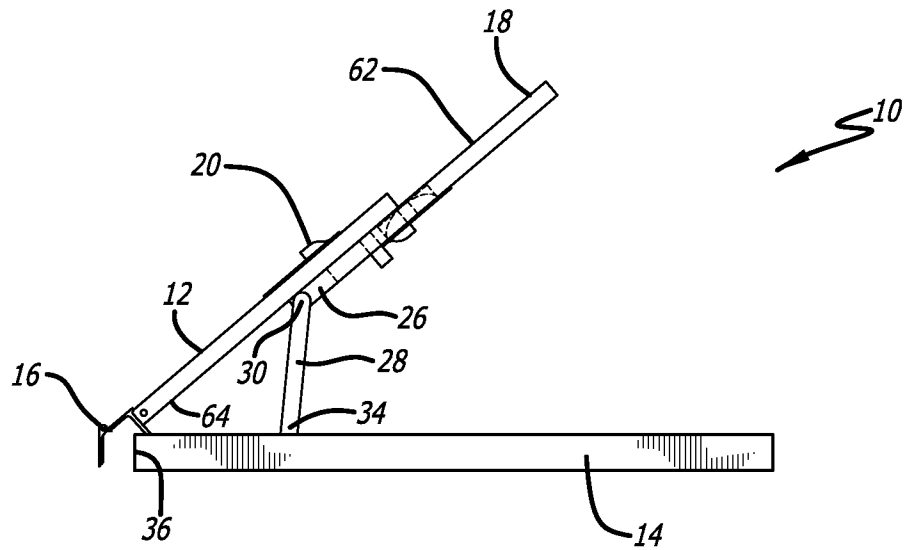

FIG. 2C

3/4

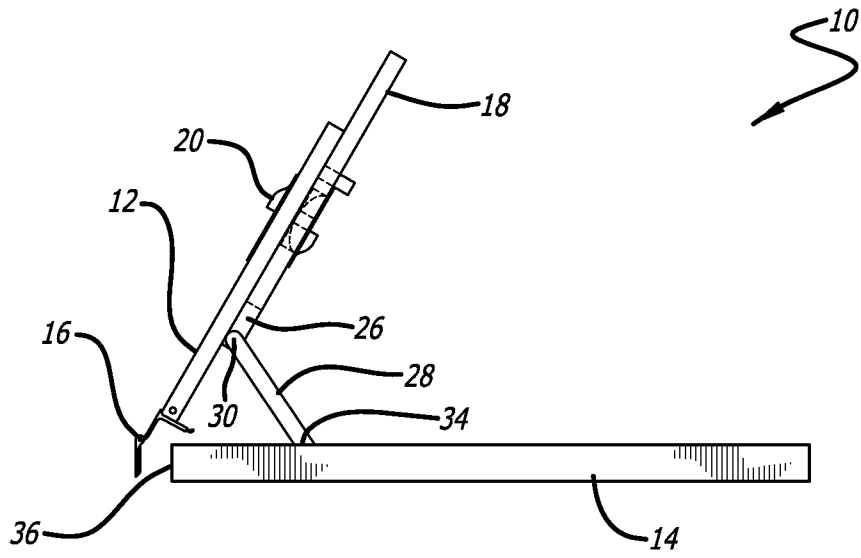

FIG. 2D

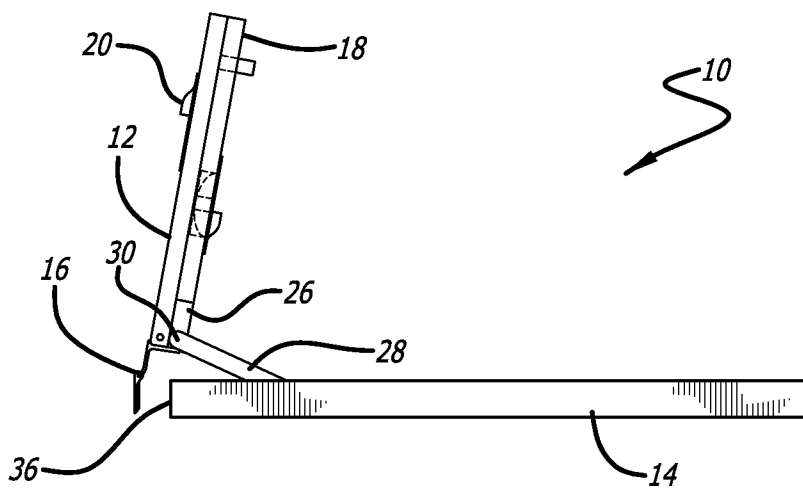

FIG. 2E

4/4

FIG. 3

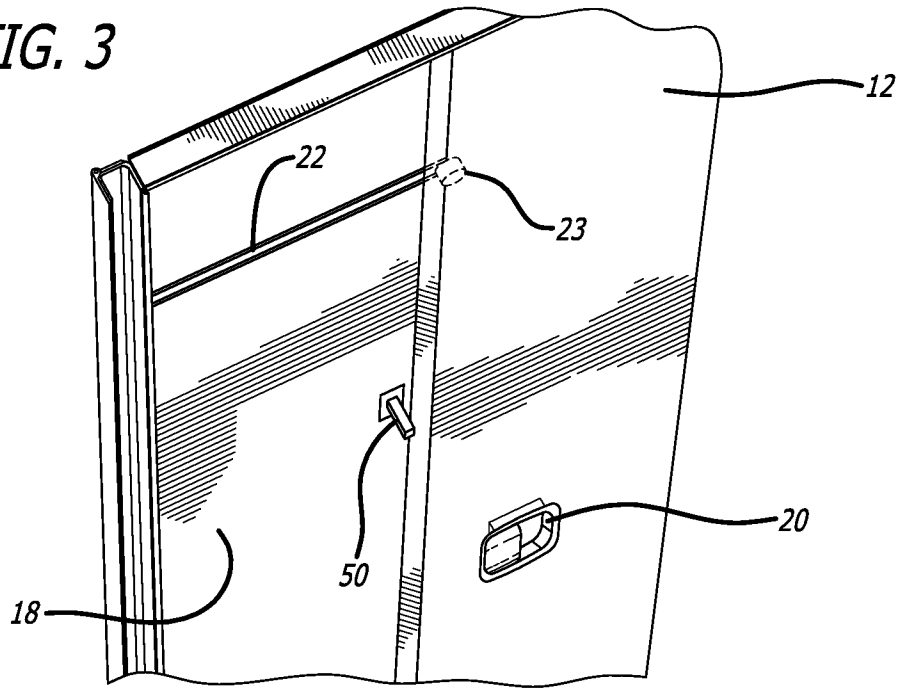
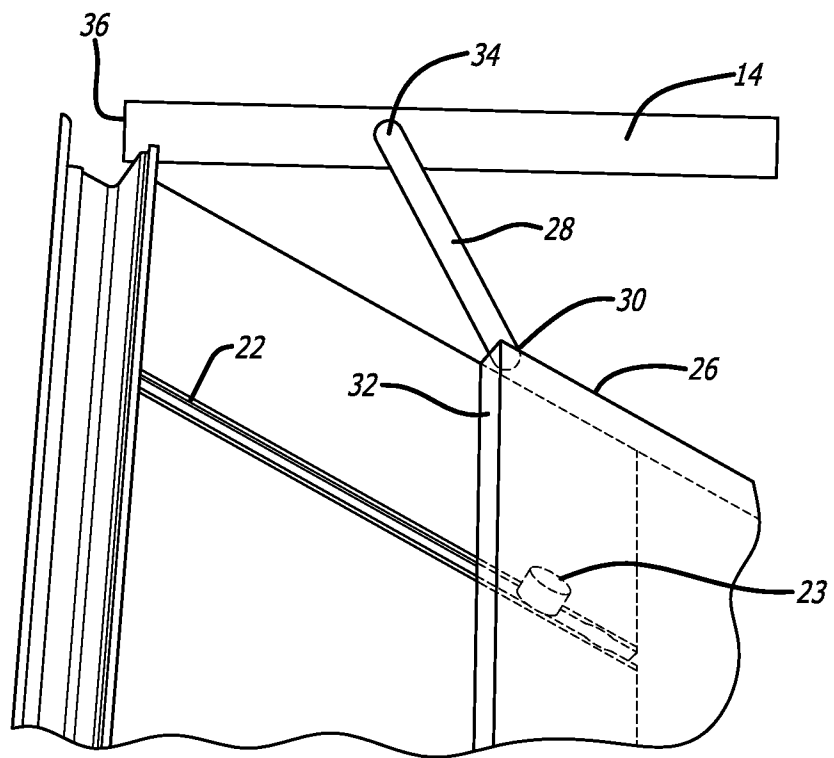

FIG. 4



INTERNATIONAL SEARCH REPORT

International application No
PCT/US2015/039598

A. CLASSIFICATION OF SUBJECT MATTER
 INV. E05F17/00 E05D15/58 B64C1/14
 ADD.
 According to International Patent Classification (IPC) or to both national classification and IPC

B. FIELDS SEARCHED
 Minimum documentation searched (classification system followed by classification symbols)
 E05F E05D B64C
 Documentation searched other than minimum documentation to the extent that such documents are included in the fields searched

Electronic data base consulted during the international search (name of data base and, where practicable, search terms used)
 EPO-Internal

C. DOCUMENTS CONSIDERED TO BE RELEVANT

Category*	Citation of document, with indication, where appropriate, of the relevant passages	Relevant to claim No.
X	DE 23 22 907 A1 (MATZANKE BRUNO) 28 November 1974 (1974-11-28)	1,4,6
Y	page 7, paragraph 3 - paragraph 4; figure 5	2,3,5
X	----- US 704 887 A (LOW FREDERIC F [US]) 15 July 1902 (1902-07-15) page 1, line 9 - line 99; figures 1-8	1,4,6
Y	----- WO 2008/090447 A2 (BI FOLD SOLUTIONS PTY LTD [AU]; SHIPMAN SIMON GARY [AU]) 31 July 2008 (2008-07-31) abstract; figures 1,3-7	2,3,5

Further documents are listed in the continuation of Box C.

See patent family annex.

* Special categories of cited documents :

"A" document defining the general state of the art which is not considered to be of particular relevance	"T" later document published after the international filing date or priority date and not in conflict with the application but cited to understand the principle or theory underlying the invention
"E" earlier application or patent but published on or after the international filing date	"X" document of particular relevance; the claimed invention cannot be considered novel or cannot be considered to involve an inventive step when the document is taken alone
"L" document which may throw doubts on priority claim(s) or which is cited to establish the publication date of another citation or other special reason (as specified)	"Y" document of particular relevance; the claimed invention cannot be considered to involve an inventive step when the document is combined with one or more other such documents, such combination being obvious to a person skilled in the art
"O" document referring to an oral disclosure, use, exhibition or other means	"&" document member of the same patent family
"P" document published prior to the international filing date but later than the priority date claimed	

Date of the actual completion of the international search 9 September 2015	Date of mailing of the international search report 21/09/2015
--	---

Name and mailing address of the ISA/ European Patent Office, P.B. 5818 Patentlaan 2 NL - 2280 HV Rijswijk Tel. (+31-70) 340-2040, Fax: (+31-70) 340-3016	Authorized officer Guillaume, Geert
--	---

INTERNATIONAL SEARCH REPORT

Information on patent family members

International application No

PCT/US2015/039598

Patent document cited in search report	Publication date	Patent family member(s)	Publication date
DE 2322907	A1	28-11-1974	NONE
US 704887	A	15-07-1902	NONE
WO 2008090447	A2	31-07-2008	NONE