



INTERNATIONAL APPLICATION PUBLISHED UNDER THE PATENT COOPERATION TREATY (PCT)

<p>(51) International Patent Classification³ : E04G 11/02</p>	<p>A1</p>	<p>(11) International Publication Number: WO 82/ 03103 (43) International Publication Date: 16 September 1982 (16.09.82)</p>
<p>(21) International Application Number: PCT/AU82/00023 (22) International Filing Date: 8 March 1982 (08.03.82) (31) Priority Application Number: PE 7894 (32) Priority Date: 6 March 1981 (06.03.81) (33) Priority Country: AU (71)(72) Applicant and Inventor: ROACH, John, William [AU/AU]; 498 High Street, Penrith, N.S.W. 2750 (AU). (74) Agent: TAYLOR, Paul, Robert; Arthur S. Cave & Co., Gold Fields House, 1 Alfred Street, Sydney, N.S.W. 2000 (AU). (81) Designated States: AU, GB, JP, US.</p>		<p>Published <i>With international search report.</i></p>

(54) Title: HIGH RISE SYSTEM

(57) Abstract

A method and apparatus for casting in situ a multi-storey building. The walls, columns and beams, and floor of each level are cast in one operation by the use of moulds (10). After the concrete has set a secondary lifting rig (12) lifts the primary lifting rig (11) to the next level and the primary lifting rig (11) then lifts the moulds (10) to the next level for the process to be repeated until the desired number of floors of the building are poured.

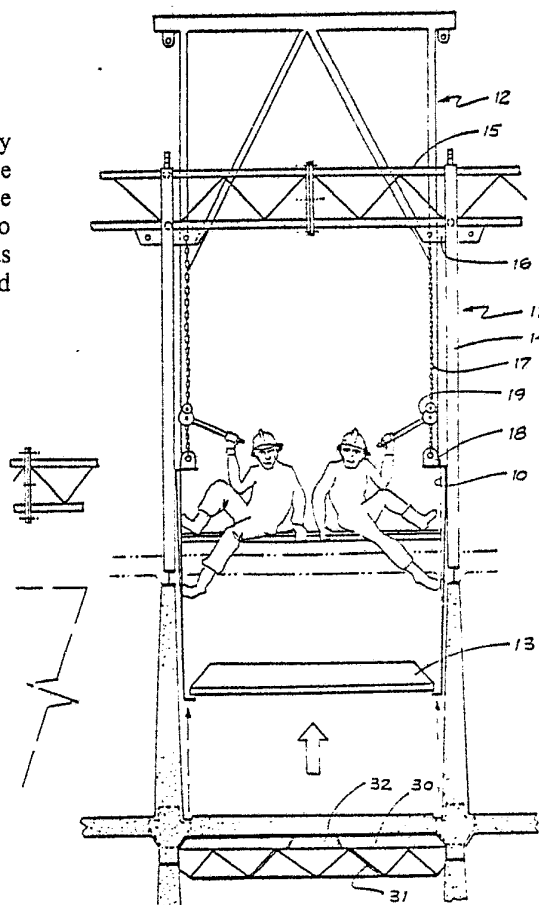

FOR THE PURPOSES OF INFORMATION ONLY

Codes used to identify States party to the PCT on the front pages of pamphlets publishing international applications under the PCT.

AT	Austria	KP	Democratic People's Republic of Korea
AU	Australia	LI	Liechtenstein
BE	Belgium	LK	Sri Lanka
BR	Brazil	LU	Luxembourg
CF	Central African Republic	MC	Monaco
CG	Congo	MG	Madagascar
CH	Switzerland	MW	Malawi
CM	Cameroon	NL	Netherlands
DE	Germany, Federal Republic of	NO	Norway
DK	Denmark	RO	Romania
FI	Finland	SE	Sweden
FR	France	SN	Senegal
GA	Gabon	SU	Soviet Union
GB	United Kingdom	TD	Chad
HU	Hungary	TG	Togo
JP	Japan	US	United States of America

- 1 -
HIGH RISE SYSTEM

This invention relates to a method of casting a multi-storey building, to apparatus for carrying out the method and to buildings constructed by the method.

It is known to cast concrete structures using steel or other moulds but hitherto the methods have been cumbersome because of difficulties in gaining access for removing the moulds after casting of the concrete has been completed.

The object of the present invention is to provide an improved method of casting in situ a multi-storey building which overcomes the difficulties inherent in prior art methods and which permits the rapid construction of a multi-storey building using the minimum of skilled labour.

According to the invention there is provided a method of casting in situ a multi-storey building comprising the steps of:-

- (1) providing a ground floor for the building,
- (2) positioning a core or mould for each room or space in the ground floor plan of the building;
- (3) positioning external shutters around the external faces of the ground floor plan,
- (4) pouring concrete into the spaces defined by the cores and the shutters to provide internal and external walls or columns and beams of the ground floor plan,
- (5) raising the cores and shutters to the level of the second floor after the concrete has cured sufficiently to remain unsupported,
- (6) erecting the mountable soffits at the top of each room or space of the ground floor plan in spaced relation to the bottom on the respective cores,
- (7) pouring concrete into the spaces defined by the cores, shutters and soffits to provide the internal and external walls or columns and beams and floors of the first floor plan and the ceiling of the ground floor plan.

The invention further provides apparatus for casting in situ a multi-storey building comprising:-

- (a) a moulding core for each room or space of the ground floor plan of the building which defines the walls or columns and beams of the room or space,



- 2 -

(b) a primary lifting rig for raising each mould to the first floor once the ground floor is cast, and,

(c) a secondary lifting rig for raising the primary lifting rig to the next floor when the mould is established in its new position.

In order that the invention may be more readily understood and put into practical effect reference will now be made to the accompanying drawings in which:-

Fig. 1 is a front elevational schematic view of apparatus according to one embodiment of the invention for casting a multi-storey building in situ,

Fig. 2 is a view similar to Fig. 1 showing the mould fixed in position ready for pouring and the primary lifting rig being moved into the next location by the secondary lifting rig,

Fig. 3 is a partial side elevation view corresponding to Fig. 1 showing the top portion of the lifting rigs,

Fig. 4 is a front elevational view of a stabiliser member secured to the top of each cast wall, and,

Fig. 5 is a side elevational view of a multi-storey building cast in situ using the method of the invention.

The apparatus shown in Figs. 1 and 2 includes a core or mould 10, a primary lifting rig 11 and a secondary lifting rig 12. Each mould 10 defines the walls of its room or space and appropriate openings for doors and windows are provided by utilising steel block outs which extend between adjacent moulds. At the bottom of each mould 10 there is a screeder 13 for finishing-off the cast floor.

The primary lifting rig 11 has four corner legs 14 which are positioned on top of the previously cast walls or beams so that the rig straddles the space or room. Each lifting rig 11 has a truss assembly 15 connected to the upper end of each leg 14. Support brackets 16 secured to the legs 14 and to the truss assembly 15 carry chains 17



- 3 -

which are secured to brackets 18 at the top of the mould 10. Each chain 17 has a manually operated lifting block 19 for raising the mould 10 to the next floor level as shown in Fig. 1. This can be modified by using a winch instead of the chain and block.

The secondary lifting rig 12 is attached to the top of the mould by lugs 20 and is thus raised whenever the mould is raised. The top of legs 20 are connected by a top plate or member 21 which has at each end pulleys 22. A lifting cable 23 extends from the top of each leg 14 around the pulley 20 to winch 24 on the primary rig 11 whereby the primary lifting rig 11 may be raised as shown in Fig. 2.

A locator bar or stabiliser member 25 is bolted to the top of each corner of each room or space and when in position, the mould 10 is bolted thereto as shown in Figs. 2 and 4.

When a multi-storey building is to be constructed, the ground floor is established to a very accurate level and smoothness with the aid of a mechanical bridge screed. A grid showing the ground floor plan of the building is then set out and a mould 10 is accurately set into position for every room or space of the ground floor plan. Reinforcing and services (electrical and plumbing) are located in the wall or column cavities defined by adjacent moulds. The external faces of the building can be formed with simple steel shutters supported vertically off the internal wall moulds and spaced at the desired wall thickness with cast in spacer pieces.

Concrete is then poured into the spaces defined by the moulds and the external shutters and following a suitable curing period the moulds are drawn vertically by the primary lifting rigs which are located directly on top of two of the cast walls or beams as shown in Fig. 3 the base of the primary lifting rig 11 has a channel member 26 which extends between the vertical legs 14. In the case of the mould for the columns and beams, the underneath of the beam



mould section is releasably hinged attached such that when the mould is to be lifted the underneath section is hinged open so that the mould slides over the concrete beam. The wall or column mould is positioned at the next floor level and adjustable cast in stabiliser brackets 25 are bolted to the inner faces of the mould and connected to the top of the cast wall or beam by a heavy duty insert cast in during the previous concrete pour. Each mould is aligned and located accurately to a tolerance of plus or minus 2 millimetres and then locked tightly into position onto the stabiliser brackets.

The legs of the primary lifting rig are then raised clear of the room or space defined by the mould by the secondary lifting rig which, as stated before, is connected to the mould.

A soffit 30 is placed in position and can be supported by truss assembly 31. The truss assemblies 31 are bolted onto the previously cast walls columns where predetermined transverse holes have been cast for this purpose. Each soffit 30 includes a grid work of flat interconnecting panels approximately 1 metre by 500 millimetres in size when viewed in a plan. These units are connected to one another and supported therebeneath. Both the supports and the soffits contain central key units 32 (in the case of the soffits) which are wedge shaped to allow for ease of dismantling against the reverse slope of the walls or beams rising from the taper of the core moulds 10.

Around the periphery of the completed soffit is fixed a cornice former which will ensure that a 80 x 80 millimetre fillet is formed around the ceiling to wall joint in each room or space. Upon completion of the erection of the soffit and cornice former, reinforcing and block outs are located. Services are then positioned and concrete then poured to finish the first floor. The concrete is first placed into the soffit and finished off to a very accurate level with an integral vibrating bridge

- 5 -

screeder which is winched across the toes of the wall or beam mould. After the floor concrete has cured sufficiently the wall or column and beam voids are then filled with concrete and accurately screeded off at the top.

The above process is repeated for all subsequent floors of the building to provide a multi-storey structure as shown in Fig. 5.

As can be seen in the drawings, each mould 10 is tapered from the bottom to the top of the mould on all faces so as to assist its movement from one floor to the next. This gives rise to a slight inward taper in the wall columns and beam structures which may typically be approximately 5° off the vertical.

Various modifications may be made in details of design, construction and the application of the method without departing from the scope and ambit of the invention the nature of which is to be determined from the preceding description.



- 6 -

CLAIMS

1. A method of casting in situ a multi-storey building comprising the steps of:-
 - (1) providing a ground floor for the building,
 - (2) positioning a core or mould for each room or space in the ground floor plan of the building;
 - (3) positioning external shutters around the external faces of the ground floor plan,
 - (4) pouring concrete into the spaces defined by the cores and the shutters to provide internal and external walls or columns and beams of the ground floor plan,
 - (5) raising the cores and shutters to the level of the second floor after the concrete has cured sufficiently to remain unsupported,
 - (6) erecting the mountable soffits at the top of each room or space of the ground floor plan in spaced relation to the bottom on the respective cores,
 - (7) pouring concrete into the spaces defined by the cores, shutters and soffits to provide the internal and external walls or columns and beams and floors of the first floor plan and the ceiling of the ground floor plan.
2. A method of claim 1 wherein the moulds and shutters of the walls and columns and beams are tapered from the bottom of the mould to the top of the mould and shutters on all faces.
3. Apparatus for casting in situ a multi-storey building comprising:-
 - (a) a moulding for each room or space of the ground floor plan of the building which defines the walls or columns and beams of the room or space,
 - (b) a primary lifting rig for raising each mould to the first floor once the ground floor is cast, and,
 - (c) a secondary lifting rig for raising the primary lifting rig to the next floor when the mould is established in its new position.



- 7 -

4. Apparatus according to claim 3 wherein each mould is tapered from the bottom to the top of the mould on all faces to facilitate the movement of the moulds from one floor to the next.
5. Apparatus according to claim 3 or 4 wherein the mould has at its bottom a screeder for finishing off the cast floor.
6. A method of casting in situ a multi-storey building substantially as hereinbefore described with reference to the accompanying drawings.
7. Apparatus for casting in situ a multi-storey building substantially as hereinbefore described with reference to the accompanying drawings.



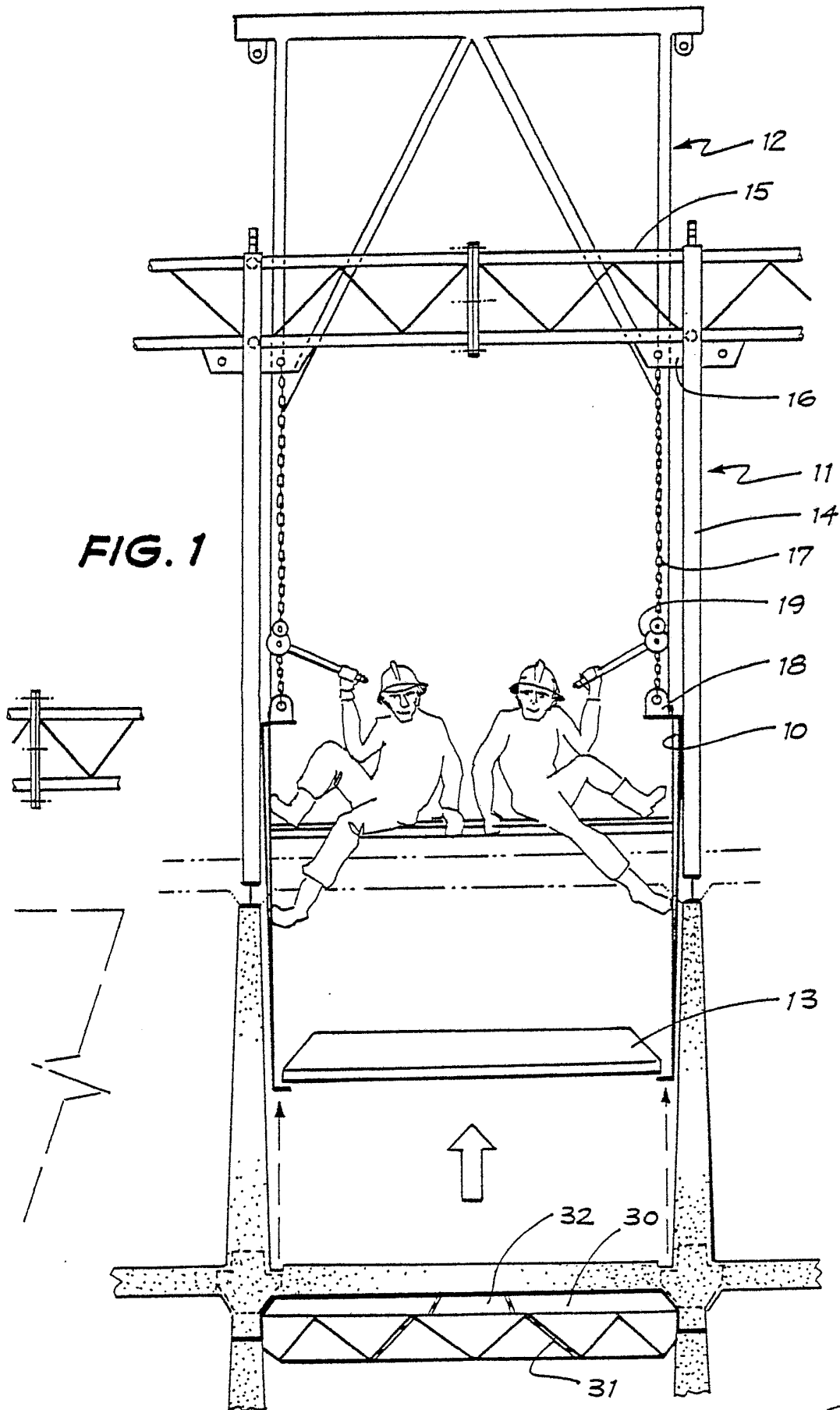

FIG. 1

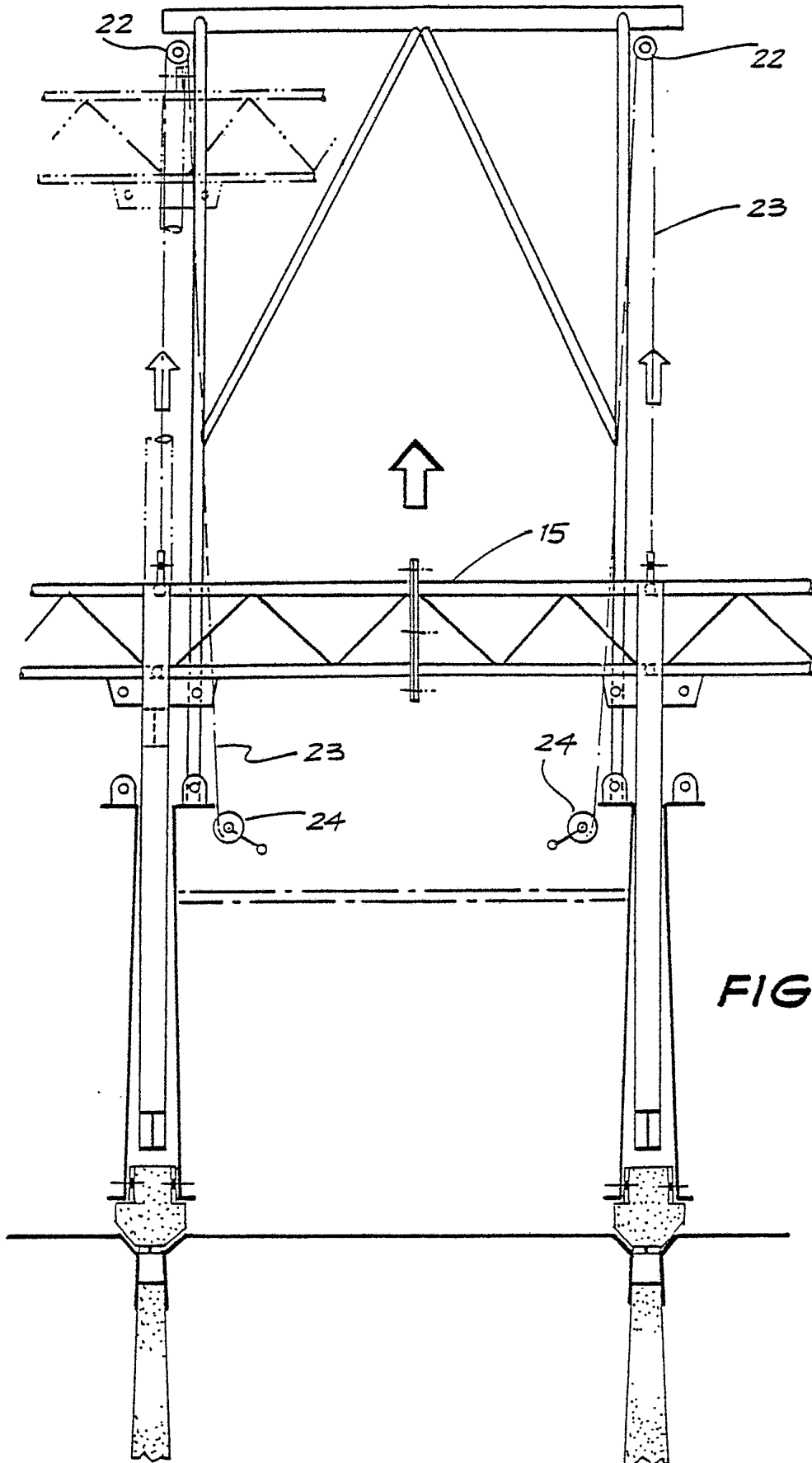

FIG. 2



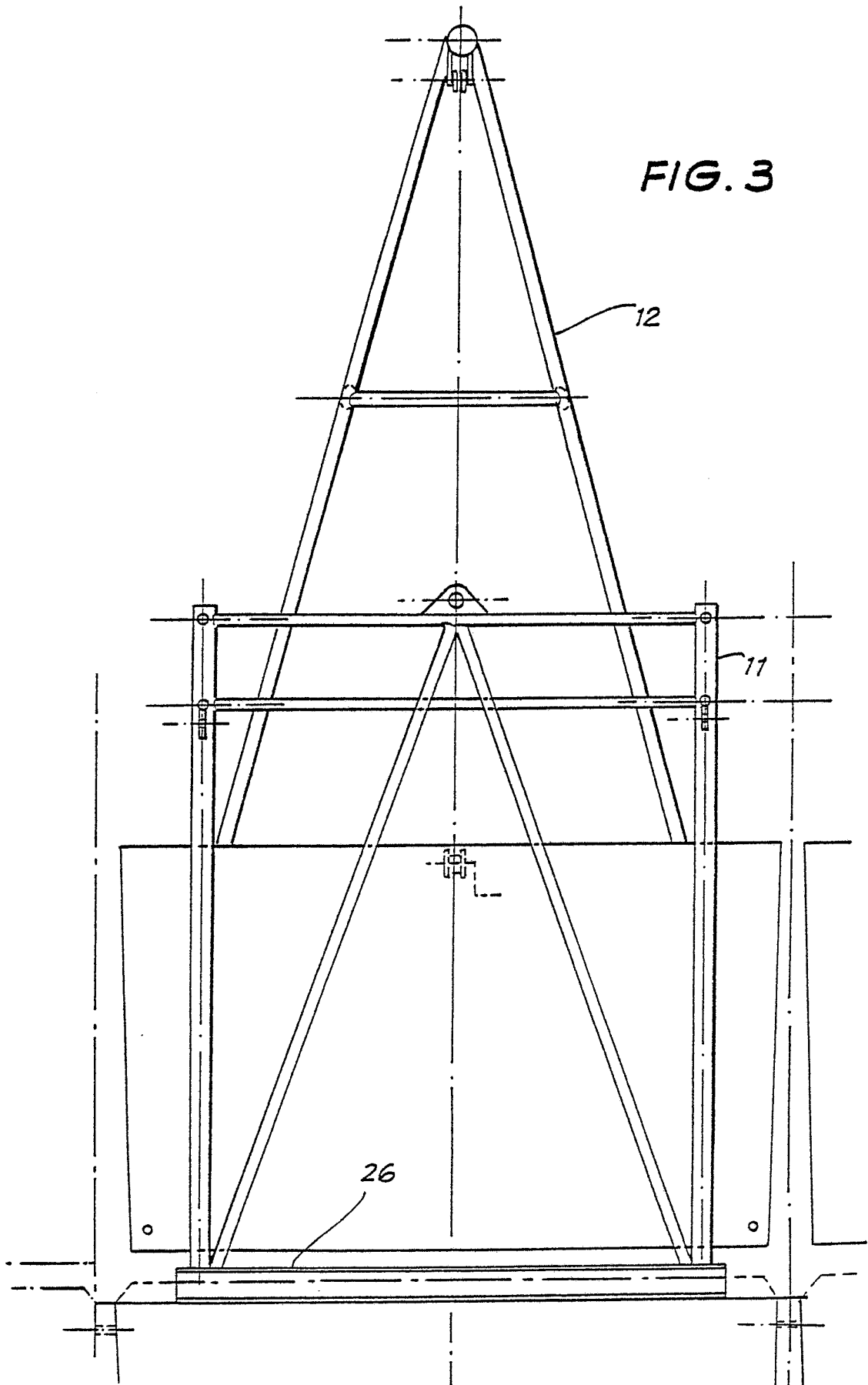

FIG. 3

FIG. 4

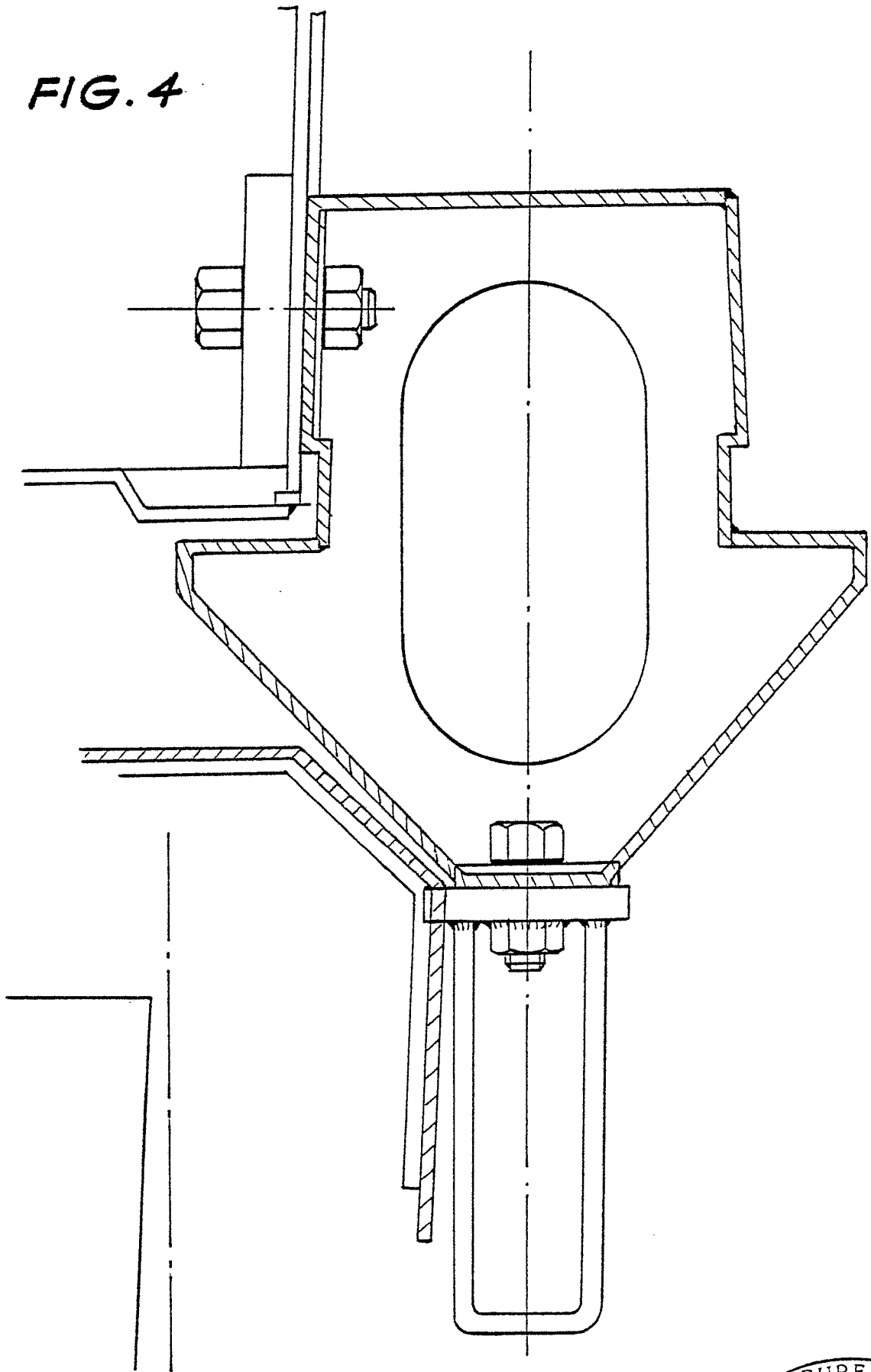
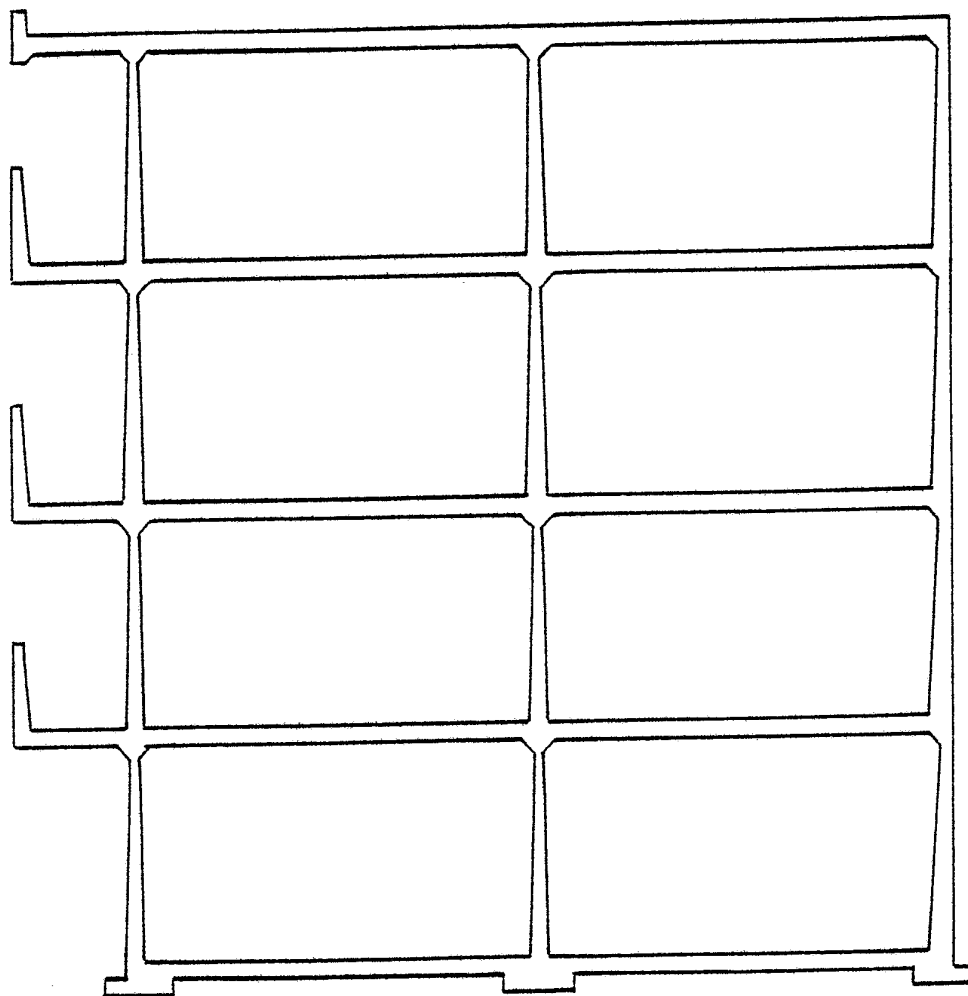

FIG. 5



INTERNATIONAL SEARCH REPORT

International Application No **PCT/AU82/00023**

I. CLASSIFICATION OF SUBJECT MATTER (if several classification symbols apply, indicate all) ³				
According to International Patent Classification (IPC) or to both National Classification and IPC				
Int. Cl ³ E04G 11/02				
II. FIELDS SEARCHED				
Minimum Documentation Searched ⁴				
Classification System	Classification Symbols			
IPC	E04G 11/02			
Documentation Searched other than Minimum Documentation to the Extent that such Documents are Included in the Fields Searched ⁵				
AU : IPC as above				
III. DOCUMENTS CONSIDERED TO BE RELEVANT ¹⁴				
Category ⁶	Citation of Document, ¹⁶ with indication, where appropriate, of the relevant passages ¹⁷	Relevant to Claim No. ¹⁸		
A,Y	US,A, 1701113 (KELLER) 5 February 1929 (05.02.29)	1		
A,Y	GB,A, 1086524 (PAPAICONOMOU) 11 October 1967 (11.10.67)	1		
X	FR,A, 884182 (GUTEHOFFNUNGSHUTTE OBERHAUSEN A.G.) 4 August 1943 (04.08.43)	1		
A,Y	DE,A, 1684430 (SIEMENS-BAUUNION GmbH) 4 December 1969 (04.12.69) See figures 1-4	1,3		
<p>¹⁵ * Special categories of cited documents:</p> <table style="width: 100%; border: none;"> <tr> <td style="width: 50%; border: none;"> <p>"A" document defining the general state of the art which is not considered to be of particular relevance</p> <p>"E" earlier document but published on or after the international filing date</p> <p>"L" document which may throw doubts on priority claim(s) or which is cited to establish the publication date of another citation or other special reason (as specified)</p> <p>"O" document referring to an oral disclosure, use, exhibition or other means</p> <p>"P" document published prior to the international filing date but later than the priority date claimed</p> </td> <td style="width: 50%; border: none;"> <p>"T" later document published after the international filing date or priority date and not in conflict with the application but cited to understand the principle or theory underlying the invention</p> <p>"X" document of particular relevance; the claimed invention cannot be considered novel or cannot be considered to involve an inventive step</p> <p>"Y" document of particular relevance; the claimed invention cannot be considered to involve an inventive step when the document is combined with one or more other such documents, such combination being obvious to a person skilled in the art.</p> <p>"&" document member of the same patent family</p> </td> </tr> </table>			<p>"A" document defining the general state of the art which is not considered to be of particular relevance</p> <p>"E" earlier document but published on or after the international filing date</p> <p>"L" document which may throw doubts on priority claim(s) or which is cited to establish the publication date of another citation or other special reason (as specified)</p> <p>"O" document referring to an oral disclosure, use, exhibition or other means</p> <p>"P" document published prior to the international filing date but later than the priority date claimed</p>	<p>"T" later document published after the international filing date or priority date and not in conflict with the application but cited to understand the principle or theory underlying the invention</p> <p>"X" document of particular relevance; the claimed invention cannot be considered novel or cannot be considered to involve an inventive step</p> <p>"Y" document of particular relevance; the claimed invention cannot be considered to involve an inventive step when the document is combined with one or more other such documents, such combination being obvious to a person skilled in the art.</p> <p>"&" document member of the same patent family</p>
<p>"A" document defining the general state of the art which is not considered to be of particular relevance</p> <p>"E" earlier document but published on or after the international filing date</p> <p>"L" document which may throw doubts on priority claim(s) or which is cited to establish the publication date of another citation or other special reason (as specified)</p> <p>"O" document referring to an oral disclosure, use, exhibition or other means</p> <p>"P" document published prior to the international filing date but later than the priority date claimed</p>	<p>"T" later document published after the international filing date or priority date and not in conflict with the application but cited to understand the principle or theory underlying the invention</p> <p>"X" document of particular relevance; the claimed invention cannot be considered novel or cannot be considered to involve an inventive step</p> <p>"Y" document of particular relevance; the claimed invention cannot be considered to involve an inventive step when the document is combined with one or more other such documents, such combination being obvious to a person skilled in the art.</p> <p>"&" document member of the same patent family</p>			
IV. CERTIFICATION				
Date of the Actual Completion of the International Search ¹⁹	Date of Mailing of this International Search Report ²⁰			
13 April 1982 (13.04.82)	19 April 1982 (19-04-82)			
International Searching Authority ¹	Signature of Authorized Officer ²⁰			
Australian Patent Office	A.S. Moore. <i>A.S. Moore</i>			