

①9



LATVIJAS REPUBLIKAS
PATENTU VALDE

①1 LV 11492 B

⑤1 Int.Cl. 6 E04H4/10

Latvijas patents uz izgudrojumu
1995.g. 30.marta Latvijas Republikas likums

①2

Īsziņas

②1	Pieteikuma numurs:	P-95-355
②2	Pieteikuma datums:	28.11.1995
④1	Pieteikuma publikācijas datums:	20.08.1996
④5	Patenta publikācijas datums:	20.12.1996
③0	Prioritāte:	
	9301488-4	30.04.1993 SE
⑧6	PCT pieteikums:	
	PCT/SE94/00390,	29.04.1994
⑧7	PCT publikācija:	
	WO 94/25707,	10.11.1994

⑦3 Īpašnieks(i):
Stig WESTLUND; Carlgrensväg 70, S-892 30
Domsjö, SE

⑦2 Izgudrotājs(i):
Stig WESTLUND (SE)

⑦4 Pilnvarotais vai pārstāvis:
Ābrams FOGELS,
Patentu birojs "ALFA-PATENTS",
Mārstaļu iela 2/4, Rīga LV-1050, LV

⑤4 Virsraksts: Pārsegs peldbaseiniem

⑤7 Kopsavilkums: Izgudrojums attiecas uz peldbaseiniem un tiem līdzīgiem baseiniem, kas aprīkoti ar apmali. Piedāvātā aizsargierīce (fig.2) izveidota kā baseina pārsegs, kuru var uzvilkt vai atlocīt baseina pārsegšanai, kā arī novilkt, ievilkt vai salocīt baseina atsegšanai. Piedāvātais baseina pārsegs ar vienu galu pievienots pirmajam turētājam (3;27) un ar otro, pretējo galu, pievienots otrajam turētājam (4;30). Pirmais turētājs (3;27) balstās uz ārpus baseina apmales izvietota atbalsta (5;26), kuram tas piestiprināts, bet otrais turētājs (4;30) pagriežami nostiprināts uz pirmā turētāja tādā veidā, ka baseina pārsegu no ievilkta stāvokļa var izvilkt baseina pārsegšanai, pagriežot otro turētāju attiecībā pret pirmo turētāju.

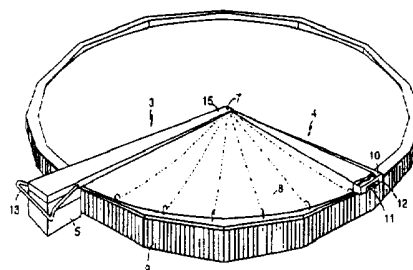

FIG.2

Izgudrojuma formula

1. Aizsargierīce peldbaseiniem vai tiem līdzīgiem baseiniem, kas aprīkoti ar apmali, izveidota kā baseina pārsegs, kuru var uzvilkt vai atlocīt baseina pārsegšanai un novilkt, ievilkt vai salocīt baseina atsegšanai, kas raksturojas ar šādu pazīmju kombināciju:

- baseina pārsegs ar vienu galu pievienots pirmajam turētājstienim (3; 27), kuram ir speciāli izveidoti abi gali, un ar otru, pretējo galu, pievienots otrajam turētājstienim (4; 30), kuram speciāli izveidoti abi gali;
- pirmais turētājstienis (3; 27) balstās uz ārpus baseina apmales izvietota fundamenta (5; 26), kuram tas piestiprināts;
- otrais turētājstienis (4; 30) ar vienu tā galu šarnīrveidīgi nostiprināts uz ass, kas izvietota vienā pirmā turētājstieņa (3; 27) galā tādā veidā, ka baseina pārsegu no ievilkta stāvokļa, kurā abi turētājstieņi atrodas tuvu viens otram, var izvilkt baseina pārsegšanai, pagriežot otro turētājstieni attiecībā pret pirmo turētājstieni;
- otrais turētājstienis izveidots ar tā garenvirzienā izvietotu līdzekli turētājstieņa vieglākai pagriešanai, kurš ir tik garš, lai vienmēr balstītos uz baseina (2; 24) apmales (9; 25).

2. Aizsargierīce peldbaseiniem pēc 1. punkta, kas atšķiras ar to, ka pirmā turētājstieņa (27) un otrā turētājstieņa (30) viens gals (28; 31) ir izvietoti uz fundamenta (26) un otrā turētājstieņa (30) gals (31) ir šarnīrveidīgi nostiprināts uz ass, kas izvietota pirmā turētājstieņa (27) galā (28).

3. Aizsargierīce peldbaseiniem pēc 1. punkta, kas **atšķiras** ar to, ka pirmais turētājstienis (3) ir šarnīrveidīgi piestiprināts pie vertikālas ass (6) uz fundamenta (5) tādā veidā, ka no neaktīva stāvokļa, kurā turētājstienis ir izvietots gar baseina (2) malu, tas var tikt pagriezts pret baseina vidusdaļu un nostiprināts darba stāvoklī, bet otrais turētājstienis (4) ar vienu tā galu ir šarnīrveidīgi nostiprināts uz otras vertikālās ass (7), kas novietota tajā pirmā turētājstieņa galā (15), kurš atrodas baseina vidusdaļā, pie kam minētā ass (7) izvietota baseina malas veidotā apļa centrā.

4. Aizsargierīce peldbaseiniem pēc 3. punkta, kas **atšķiras** ar to, ka pirmais (3) un otrais (4) turētājstienis ir savienoti divdaļīgas kasetes veidā, kurā pirmais turētājstienis (3) veido kasetes augšējo daļu, bet otrais turētājstienis (4) veido kasetes apakšējo daļu.

5. Aizsargierīce peldbaseiniem pēc 3. vai 4. punkta, kas **atšķiras** ar to, ka līdzeklis turētājstieņa atvieglotai pagriešanai (11, 12) balstās uz rullīša un tā garums atbilst starpībai starp lielāko un mazāko attālumu no baseina centra līdz tā apmalei (9).

6. Aizsargierīce peldbaseiniem pēc 4. punkta, kas **atšķiras** ar to, ka tā ietver fiksatoru (13), ar kura palīdzību kaseti (3, 4) var nostiprināt neaktīvā stāvoklī tuvu baseina apmalei (9), kā arī nostiprināt augšējo turētājstieni (3) darba stāvoklī, kurā tā izvirzītais gals (15) atrodas baseina (2) centrā.

7. Aizsargierīce peldbaseiniem pēc 6. punkta, kas **atšķiras** ar to, ka augšējā turētājstieņa (3) uz fundamenta (5) novietotais gals nostiprināts ar viras veida stiprinājumu (14), kas dod iespēju turētājstieņa (3) izvirzīto galu (15) pacelt uz augšu, kad turētājstieni (3) punktā (16) ceļ ar fiksatoru (13).

8. Aizsargierīce peldbaseiniem pēc jebkura no 3. līdz 7. punktam, kas **atšķiras** ar to, ka baseina pārsegu (8) paredzēts nostiprināt uz baseina

apmales (9) ar vairākiem nostiprināšanas līdzekļiem (17), kas izvietoti pa baseina aploci.

9. Aizsargierīce peldbaseiniem pēc 8. punkta, kas atšķiras ar to, ka nostiprināšanas līdzeklis (17) sastāv no pirmā elementa (18), kas paredzēts piestiprināšanai pie baseina pārsega (8), un otrā elementa (19), kas paredzēts ieāķēšanai baseina apmalē (9) izveidotā iedobumā (20), un abi elementi (18, 19) ir savienoti ar stieni (21), kas nospriegots ar atsperi tā, ka pirmo elementu (18) var atvilkt no otrā elementa (19), pārvarot atsperes (22) pretestību.

This invention relates to a protection device for swimming pools and similar types of pools, which are provided with a surrounding pool edge, the protection device comprising a pool cover which can be pulled or folded out for covering the pool and be pulled, retracted or folded in for discovering the pool.

5 Nowadays there are requirements that swimming pools shall be protected when not used. The reason for that is that children shall be prevented from falling into the pool and from drowning. An essential advantage with a pool cover is partly that the vaporisation from the pool is reduced, partly that the wastage of additives is prevented. Furthermore, the number of swimming pools has strongly increased lately. These facts taken
10 together have had the consequence that the demand for pool covers has strongly risen.

By American patent No. 3.008.148 is previously known a pool cover for protection of swimming pools having a circular design. The pool cover is intended to be folded out and folded in. However, the device has a very complicated construction. Thus, the pool cover shall be kept in place in the pool by means of a cylinder functioning as a
15 ballast device and being intended to be placed on the bottom of the pool in its centre part. From this cylinder goes up an essentially vertical pipe which in its upper end is connected with the pool cover and keeps the same in place. When the pool shall be used, the cylinder-like lump and the pool cover have accordingly to be lifted away from the pool which is a very complicated measure. Due to that fact, the known pool cover has not had
20 a great importance.

This invention intends to remove the problems with known technique and to provide a pool cover which is very simple to fasten to the pool when this one is not used and to take away from the pool when this one shall be used. This has been made possible by a pool protection of the kind mentioned by way of introduction which is characterized
25 by the combination of the following features:

- The pool cover has a first end portion, which is connected to a first, elongated carrier provided with two end portions, and a second, opposite end portion which is connected to a second, elongated carrier, provided with two end portions;

30 - The first carrier is fastened to and borne by a fundament which is positioned outside the pool edge;

- The second carrier at its one end portion is pivotally journalled at the one end portion of the first carrier about an essentially vertical, first shaft so that the pool cover from a retracted position where the two carriers are close to each other can be brought to cover the pool by pivoting out the second carrier in relation to the first one;

The second carrier has elongated, movement-facilitating means which are directed in the longitudinal direction of the carrier and which has such an extension that a part of the means will always be in contact with the edge surrounding the pool.

Further features of the invention will appear more closely below in connection with the description of two preferred embodiments of the pool protection according to the invention. In this connection reference is made to the accompanying drawings, where Fig 1 shows a view from above of a first embodiment of the pool protection with the pool cover in an inactive position for an essentially round swimming pool, the pool edge surrounding the swimming pool comprising a pool border, Fig 2 shows a perspective view of the swimming pool with a pool protection, the pool cover being partly in an active position, Fig 3 shows a cross section of the pool protection, taken along the line III-III of fig 1, Fig 4 shows a view of the pool protection according to fig 1, seen in the direction of the arrows IV-IV, Fig 5 shows a plurality of devices for fastening the pool cover to the border of the swimming pool, Fig 6 shows a detailed illustration of a fastening device of the kind shown in fig 5, and Fig 7 shows a schematical illustration of a second embodiment of the pool cover.

Referring to figures 1, 2 is shown there the pool cover 1 applied on an essentially round swimming pool 2. The pool cover 1 comprises two elongated carriers 3, 4, which, when the pool protection is in an inactive position, are arranged like a two-piece cassette with the one carrier 3 positioned above the other one 4.

The cassette is fastened to and born by a fundament 5 which is preferably fixed in the ground by casting just outside the pool itself. Furthermore, the cassette is pivotally journalled about an essentially vertical shaft 6 in the fundament so that it can take different positions in relation to this one, preferably an active position (indicated by A in fig 1) when the outer end of the cassette projects essentially to the mid portion of the pool, and an inactive position (indicated by B in fig 1) when the cassette is pivoted in to the pool edge in order not to be an obstacle to those who use the swimming pool.

In fig 2 is shown the lower cassette part. i.e. the carrier 4 extracted from the upper cassette part, i.e. the carrier 3. In order that this shall be possible, the lower carrier 4 is pivotally arranged on the upper carrier 3 at the outer end portion of this one about an essentially vertical shaft 7. Furthermore, the lower carrier is box-shaped and is intended to contain the pool cover 8 itself (see fig 3), the one end of which is fastened to the upper carrier 3, whereas its other, opposite end is fastend to the lower carrier 4. The upper carrier 3 is preferably made of aluminium profiles, which overlap each other on their top

sides, and has a design which narrows in the direction towards its free end.

As is shown in fig 2 the swimming pool has a surrounding border 9. On the top side of this border the lower carrier 4 is intended to move when extracting the pool cover 8. In order to facilitate this movement, the end portion 10 of the lower carrier 4, intended to be in contact with the border 9, has two roller-like means 11, 12. These means 11, 12 are essentially parallel with the carrier 4 and has such a length that even if the pool is not completely round, for instance if it is kidney-shaped, they shall be in contact with the top side of the pool border 9. For this purpose the length of the roller means shall be the same as the difference between the greatest and the least distance between the pool border and the centre of the pool.

The pool protection is provided with a locking device 13, (see fig 2, 4), which is designed like a handle, and by which the cassette can be locked in its active position in the centre of the pool and in its inactive position at the peripheral part of the pool. The inner end portion of the upper carrier 3 has a hinge-like fastening 14 in relation to the fundament 5. Due to that fact a raising of the outer end portion 15 of the carrier 3 is made possible, when a pressure from below is applied onto the carrier 3 at the point 16 (see fig 4) by means of the locking device 13. This means that, when the pool cover 8 covers the pool 2, the outer end portion 15 of the carrier 3 brings the pool cover 8 at the centre of the pool with it, which has the positive effect that the drainage of rain water from the pool cover 8 is improved, whereby the rain water is prevented from streaming down into the pool.

As is apparent from figs 5, 6, the pool protection comprises a great number of devices 17 for fastening the pool cover 8 to the pool border 9. Due to that fact it is possible to prevent for instance strong winds to catch the pool cover and to lift it up. These fastening devices 17 are positioned at a distance from each other around the periphery of the pool.

Each fastening device 17 comprises a first means 18 which is intended to be fastened in the pool cover 8 and a second means 19 which is intended to be fastened by hooking in a cavity 20 made in the upper part of the pool border 9. The two means 18, 19 are connected with each other by means of a bar 21 which is spring-loaded, whereby the means 18 has a possibility to get further away from the means 19 against the action of the spring 22. This fact facilitates the raising of the pool cover 8, especially if the distance from the centre of the pool to the pool edge varies around the periphery of the pool, which as has been mentioned previously is made in order to facilitate the drainage of rain

water.

When covering the swimming pool 2 the following is made. In that connection is supposed that the two-piece cassette 3, 4 is placed in an inactive position at a peripheral part of the pool.

5 The cassette 3, 4 is pivoted out so that its free end portion ends up at the centre part of the swimming pool 2. In this connection, the upper carrier 3 is locked by means of the locking device 13. In this position the lower carrier 4 is resting on the top side of the border 9 at its inner portion and is at its outer end connected with the outer end of the upper carrier 3 by means of the shaft 7, the lower carrier 4 being pivotally arranged in
10 relation to the upper carrier about the mentioned shaft. Thereafter the lower carrier 4 is pivoted out from its inactive position under the upper carrier 3. In this connection, the roller means roll on the top side of the border 9. At the same time the pool cover 8 slides out from the lower carrier 4 and begins to cover the pool. The lower carrier 4 is rolled on the top side of the border 9 round the entire pool so that, after a turning of 360°, it ends
15 up under the upper carrier 3. In this position, the entire pool 2 is covered by the pool cover 8. At the same time as the pool cover 8 is folded out, the same is fixed by locking on the top side of the pool border 9 by the fastening devices 17. Finally, the pool cover 8 is raised at the centre of the pool 2 by means of the locking device 13.

When discovering the pool the different steps are made in an opposite order and
20 direction, the loosening of the fastening devices 17 having to be started at the imagined terminal position of the pool cover.

In fig 7 is shown a schematical illustration of a second embodiment of the pool protection according to the invention. This embodiment is suitable to be used on pools having an unusual design, for instance kidney-shaped ones as in the figure.

25 Even the swimming pool 24 according to fig 7 has a surrounding pool border 25. Outside the pool edge is arranged a fundament 26 in which a first carrier 27, provided with two end portions 28, 29, is fastened and borne. In this connection the first end portion of the carrier 27 is arranged in the fundament 26. A second carrier 30, provided with two end portions 31, 32, is pivotally journalled with its one end portion 31 at the
30 first end portion 28 of the first carrier so that the second carrier 30 can be pivoted out in relation to the first carrier 27.

In the same way as in the first embodiment this second one is intended to comprise a pool cover provided with two end portions. The one end portion is intended to be connected to the first carrier 27, whereas the second end portion is intended to be

connected to the second carrier 30. Due to that fact, the pool cover will cover the pool 24 when the second carrier 30 is pivoted out in relation to the first carrier 27.

In order to facilitate the movement of the second carrier 30 on the pool edge 25, the former one is provided with elongated, movement-facilitating means which are
5 directed in the longitudinal direction of the carrier. These means have such an extension that a part of the means will always be in contact with the edge 25 surrounding the pool
24.

The invention is of course not limited to the mentioned embodiments but can be modified within the scope of the following claims. The carriers of the end portions of the
10 pool cover, for instance, can be in the same plane and accordingly be placed beside each other in an inactive position. Furthermore, the pool itself could be dug into the ground which would mean that no projecting border would be needed.

Claims

1. A protection device for swimming pools and similar types of pools, which are provided with a surrounding pool edge, the protection device comprising a pool cover which can be pulled or folded out for covering the pool and be pulled, retracted or folded
5 in for decovering the pool, c h a r a c t e r i z e d by the combination of the following features:

- The pool cover has a first end portion, which is connected to a first elongated carrier (3;27) provided with two end portions, and a second, opposite end portion, which is connected to a second, elongated carrier (4; 30), provided with two end portions;

10 - The first carrier (3; 27) is fastened to and borne by a fundament (5; 26) positioned outside the pool edge;

- The second carrier (4; 30) at its one end portion is pivotally journalled at the one end portion of the first carrier (3; 27) so that the pool cover from a retracted position where the two carriers are close to each other can be brought to cover the pool by
15 pivoting out the second carrier in relation to the first carrier;

- The second carrier (4; 30) has elongated, movement-facilitating means which are directed in the longitudinal direction of the carrier and which have such an extension that a part of the means will always be in contact with the edge (9; 25) surrounding the pool (2; 24).

20 2. A pool protection according to claim 1, c h a r a c t e r i z e d in that the first end portion (28; 31) of the first (27) and the second (30) carrier are arranged at the fundament (26) and that the first end portion (31) of the second carrier (30) is pivotally journalled at the first end portion (28) of the first carrier (27).

3. A pool protection according to claim 1, c h a r a c t e r i z e d in that the first
25 carrier (3) is pivotally journalled in the fundament (5) about an essentially vertical, first shaft (6) so that from an inactive position, where the carrier is positioned along a peripheral part of the pool (2), can be pivoted out towards the centre part of the pool and be fixed in an active position, and that the second carrier (4) with its one end portion is pivotally journalled at the end portion (15) of the first carrier, being at the centre part of
30 the pool, about an essentially vertical, second shaft (7), whereby this shaft (7) is positioned at the centre of a circle circumscribing the pool.

4. A pool protection according to claim 3, c h a r a c t e r i z e d in that the first (3) and the second carrier (4) are put together to a two-piece cassette, the first carrier (3) comprising an upper part of the cassette, whereas the lower carrier (4) comprises a lower

part of the cassette.

5. A pool protection according to claim 3 or 4, characterized in that the movement-facilitating means (11, 12) comprise roller means and have a length which essentially corresponds to the difference between the greatest and the least distance
5 between the pool edge (9) and the centre of the pool.

6. A pool protection according to claim 4, characterized in that it comprises a device (13) by means of which the cassette (3, 4) can be fixed by locking in an inactive position close to the pool edge (9) and the upper carrier (3) in an active position, where its outer end portion (15) is positioned at the centre of the pool (2).

10 7. A pool protection according to claim 6, characterized in that the inner end portion of the upper carrier (3) has a hinge-like fastening (14) in relation to the fundament (5), whereby the outer end portion (15) of the carrier (3) can be lifted upwards when a pressure from below is applied onto the carrier (3) at the point (16) by means of the locking device (13).

15 8. A pool protection according to any one of the claims 3-7, characterized in that the pool cover (8) is intended to be fastened on the pool edge (9) by means of a plurality of fastening devices (17) which are positioned around the periphery of the pool.

20 9. A pool protection according to claim 8, characterized in that each fastening device (17) comprises a first means (18) which is intended to be fastened in the pool cover (8) and a second means (19) which is intended to be fastened by hooking in a cavity (20) made in the pool edge (9), and that the two means (18, 19) are connected with each other by a bar (21), which is spring-loaded, whereby the means (18) can be moved away from the means (19) against the action of the spring (22).

25 -----

1/5

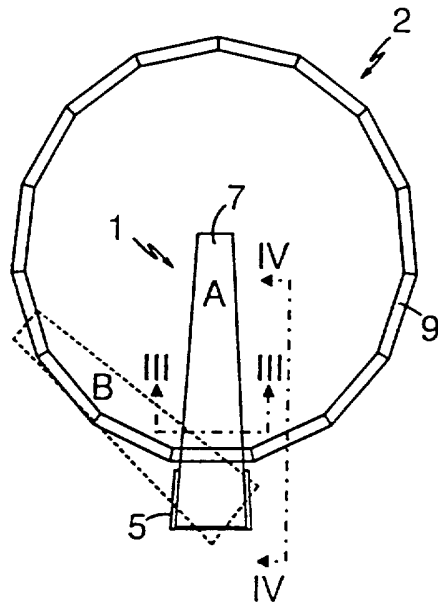

FIG. 1

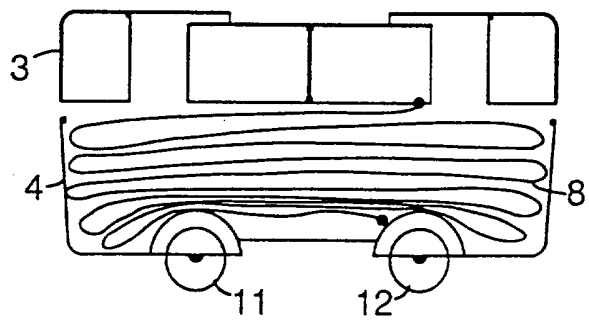

FIG. 3

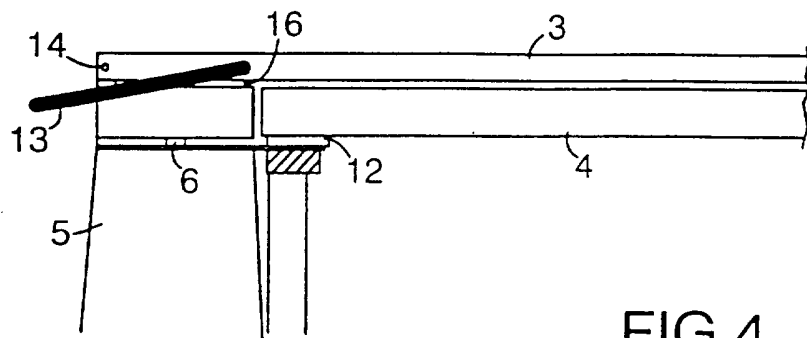

FIG. 4

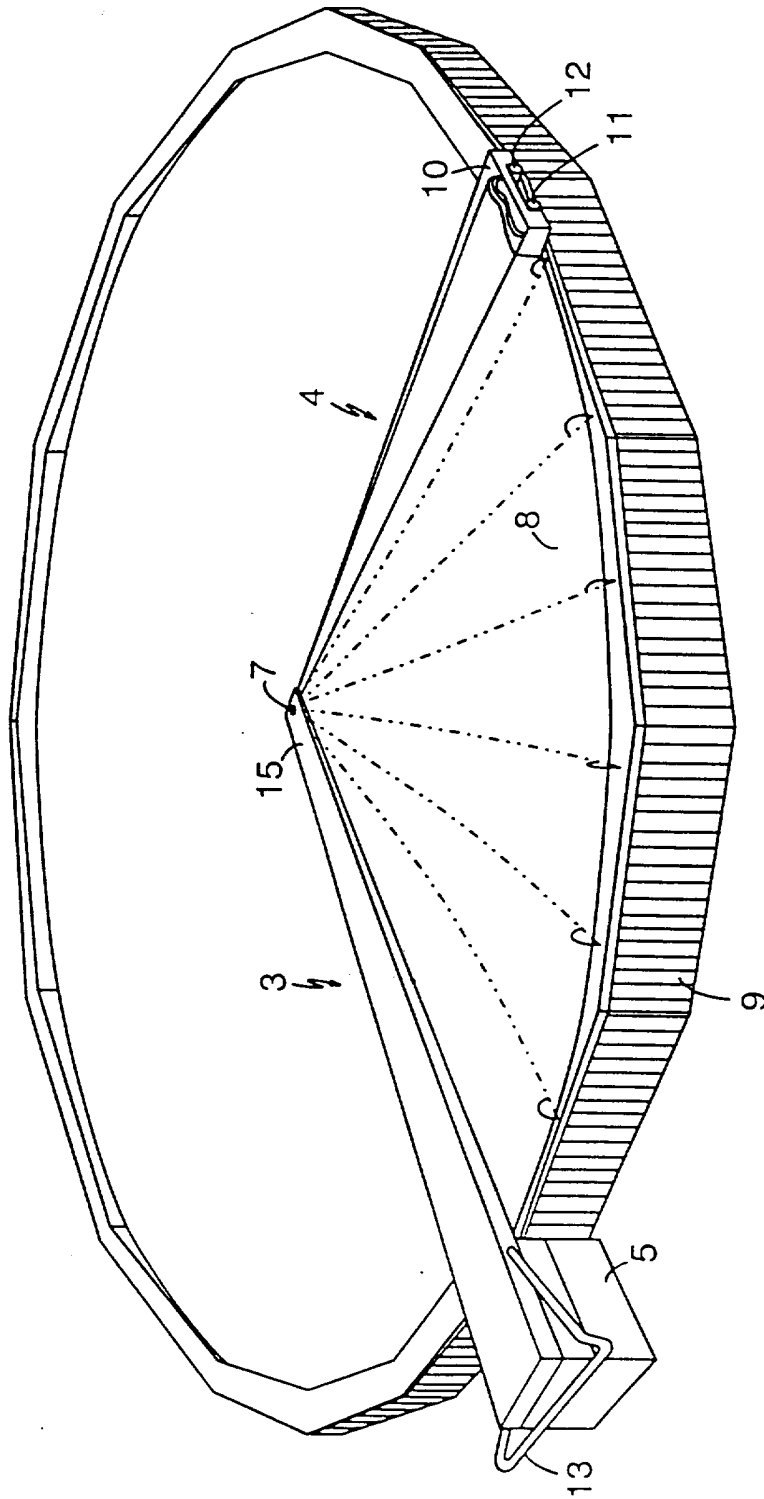

FIG.2

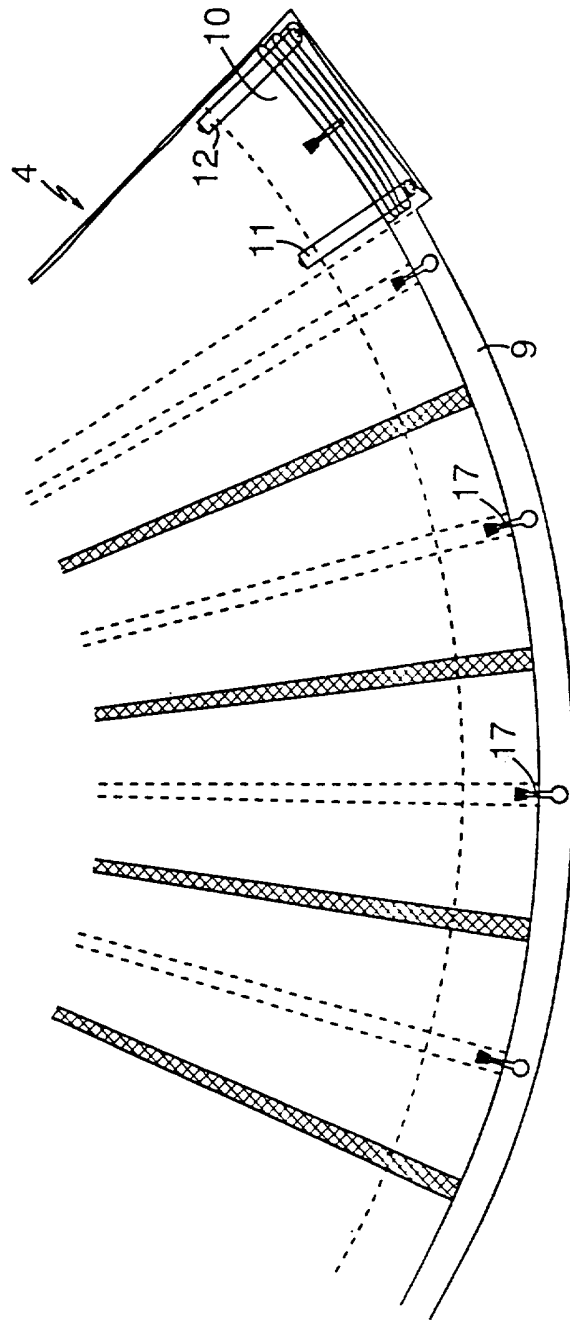

FIG.5

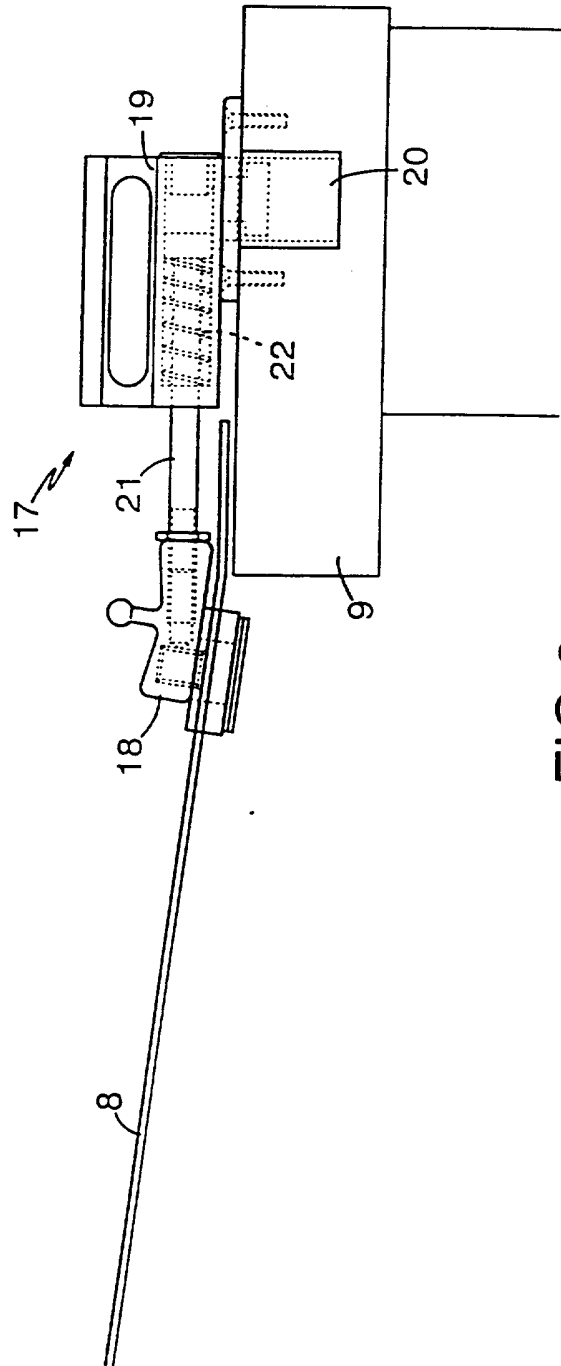

FIG.6

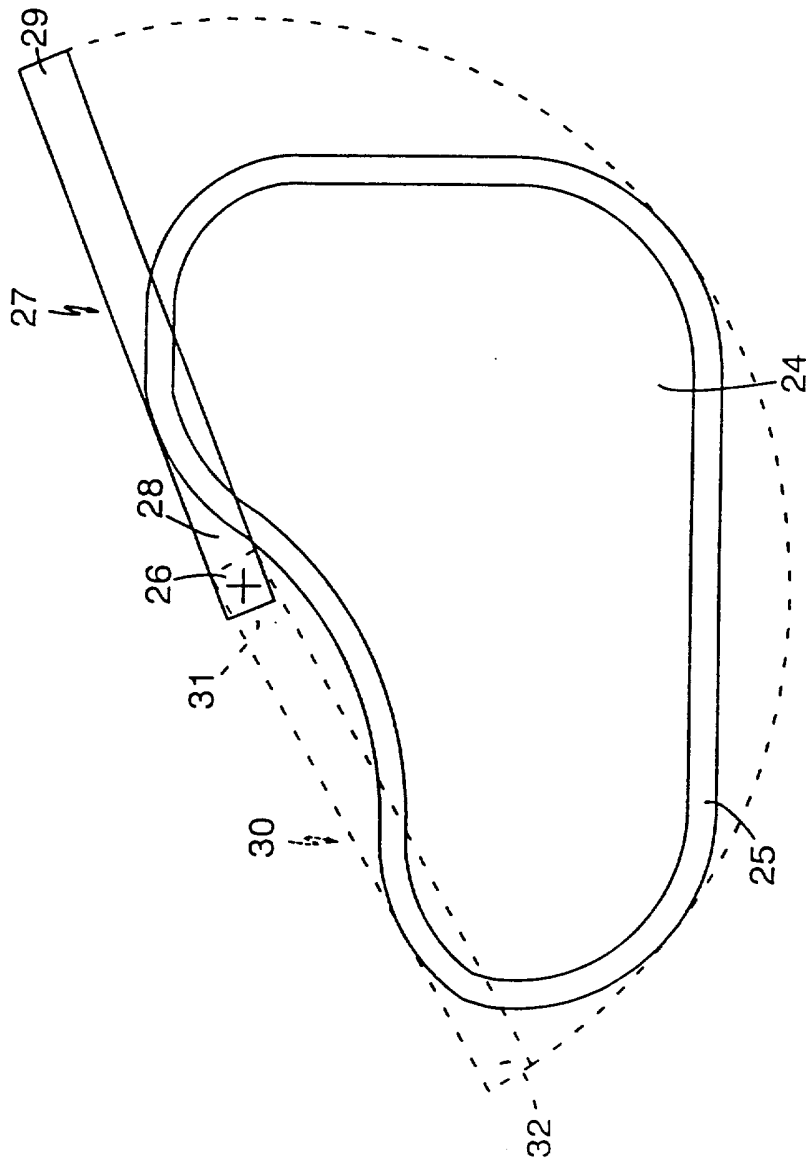

FIG.7