

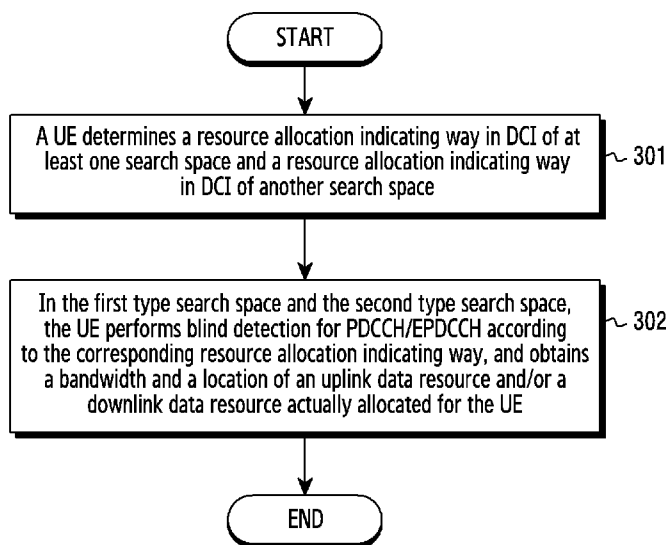

- (51) International Patent Classification: *H04W 72/12* (2009.01) *H04W 72/04* (2009.01)
- (71) Applicant: SAMSUNG ELECTRONICS CO., LTD. [KR/KR]; 129, Samsung-ro, Yeongtong-gu, Suwon-si, Gyeonggi-do 16677 (KR).
- (21) International Application Number: PCT/KR2017/005611
- (72) Inventors: FU, Jingxing; 18/F Sun Palace Building, No.12A, TaiYangGong Middle Rd,Chaoyang District, Beijing 100028 (CN). YU, Bin; 18/F Sun Palace Building, No.12A, TaiYangGong Middle Rd,Chaoyang District, Beijing 100028 (CN). QIAN, Chen; 18/F Sun Palace Building, No.12A, TaiYangGong Middle Rd,Chaoyang District, Beijing 100028 (CN). XIONG, Qi; 18/F Sun Palace Building, No.12A, TaiYangGong Middle Rd,Chaoyang District, Beijing 100028 (CN). HAO, Chenxi; 18/F Sun Palace Building, No.12A, TaiYangGong Middle Rd,Chaoyang District, Beijing 100028 (CN).
- (22) International Filing Date: 30 May 2017 (30.05.2017)
- (25) Filing Language: English
- (26) Publication Language: English
- (30) Priority Data:
- | | | |
|----------------|-------------------------------|----|
| 201610371842.7 | 30 May 2016 (30.05.2016) | CN |
| 201611008262.8 | 16 November 2016 (16.11.2016) | CN |
| 201710149997.0 | 14 March 2017 (14.03.2017) | CN |
| 201710373245.2 | 24 May 2017 (24.05.2017) | CN |
- (74) Agent: KWON, Hyuk-Rok et al.; 2F, 28, Gyeonghui-gung-gil, Jongro-gu, Seoul 03175 (KR).

(54) Title: RESOURCE SCHEDULING METHOD AND APPARATUS



(57) Abstract: The present disclosure relates to a pre-5th-Generation (5G) or 5G communication system to be provided for supporting higher data rates Beyond 4th-Generation (4G) communication system such as Long Term Evolution (LTE). The present disclosure provides a resource scheduling method, which includes: determining, by a UE, a resource allocation indicating way in DCI of a first type search space and a resource allocation indicating way in DCI of a second type search space, wherein the resource allocation indicating way comprises an allocation unit of a UE frequency resource and a bandwidth and a location of all frequency resources available for UE frequency resource allocation; in the first type search space and the second type search space, performing, by the UE, blind detection for PDCCH/EPDCCH on the bandwidth and the location of all the frequency resources available for the UE frequency resource allocation in the corresponding resource allocation indicating way according to the allocation unit of the UE frequency resource in the corresponding resource allocation indicating way, determining a bandwidth and a location of an uplink resource and/or a downlink resource actually allocated for the UE. According to the present disclosure, in a condition that the UE cannot support the entire system bandwidth, an uplink resource and a downlink resource allocated by a base station can still be appropriately determined.



(81) Designated States (*unless otherwise indicated, for every kind of national protection available*): AE, AG, AL, AM, AO, AT, AU, AZ, BA, BB, BG, BH, BN, BR, BW, BY, BZ, CA, CH, CL, CN, CO, CR, CU, CZ, DE, DJ, DK, DM, DO, DZ, EC, EE, EG, ES, FI, GB, GD, GE, GH, GM, GT, HN, HR, HU, ID, IL, IN, IR, IS, JP, KE, KG, KH, KN, KP, KR, KW, KZ, LA, LC, LK, LR, LS, LU, LY, MA, MD, ME, MG, MK, MN, MW, MX, MY, MZ, NA, NG, NI, NO, NZ, OM, PA, PE, PG, PH, PL, PT, QA, RO, RS, RU, RW, SA, SC, SD, SE, SG, SK, SL, SM, ST, SV, SY, TH, TJ, TM, TN, TR, TT, TZ, UA, UG, US, UZ, VC, VN, ZA, ZM, ZW.

(84) Designated States (*unless otherwise indicated, for every kind of regional protection available*): ARIPO (BW, GH, GM, KE, LR, LS, MW, MZ, NA, RW, SD, SL, ST, SZ, TZ, UG, ZM, ZW), Eurasian (AM, AZ, BY, KG, KZ, RU, TJ, TM), European (AL, AT, BE, BG, CH, CY, CZ, DE, DK, EE, ES, FI, FR, GB, GR, HR, HU, IE, IS, IT, LT, LU, LV, MC, MK, MT, NL, NO, PL, PT, RO, RS, SE, SI, SK, SM, TR), OAPI (BF, BJ, CF, CG, CI, CM, GA, GN, GQ, GW, KM, ML, MR, NE, SN, TD, TG).

Published:

— with international search report (Art. 21(3))

Description

Title of Invention: RESOURCE SCHEDULING METHOD AND APPARATUS

Technical Field

- [1] The present disclosure relates to radio communication technical fields, and more particularly, to a resource scheduling method and apparatus.

Background Art

- [2] To meet the demand for wireless data traffic having increased since deployment of 4th generation (4G) communication systems, efforts have been made to develop an improved 5th generation (5G) or pre-5G communication system. Therefore, the 5G or pre-5G communication system is also called a 'Beyond 4G Network' or a 'Post Long Term Evolution (LTE) System'.
- [3] The 5G communication system is considered to be implemented in higher frequency (mmWave) bands, e.g., 60GHz bands, so as to accomplish higher data rates. To decrease propagation loss of the radio waves and increase the transmission distance, the beamforming, massive multiple-input multiple-output (MIMO), Full Dimensional MIMO (FD-MIMO), array antenna, an analog beam forming, large scale antenna techniques are discussed in 5G communication systems.
- [4] In addition, in 5G communication systems, development for system network improvement is under way based on advanced small cells, cloud Radio Access Networks (RANs), ultra-dense networks, device-to-device (D2D) communication, wireless backhaul, moving network, cooperative communication, Coordinated Multi-Points (CoMP), reception-end interference cancellation and the like.
- [5] In the 5G system, Hybrid frequency shift keying (FSK) and quadrature amplitude modulation (FQAM) and sliding window superposition coding (SWSC) as an advanced coding modulation (ACM), and filter bank multi carrier (FBMC), non-orthogonal multiple access (NOMA), and sparse code multiple access (SCMA) as an advanced access technology have been developed.

Disclosure of Invention

Technical Problem

- [6] The present disclosure provides a resource scheduling method and apparatus, in a condition that a UE cannot support the entire system bandwidth, an uplink resource and a downlink resource allocated by a base station can still be appropriately determined.

Solution to Problem

- [7] In order to improve the intention above, the present disclosure provides technical

solutions as follows.

- [8] A resource scheduling method includes determining, by a user equipment (UE), a resource allocation indicating way in downlink control information (DCI) of a first type search space and a resource allocation indicating way in DCI of a second type search space, wherein the resource allocation indicating way includes an allocation unit of a UE frequency resource and a bandwidth and a location of all frequency resources available for UE frequency resource allocation, in the first type search space and the second type search space, performing, by the UE, blind detection for Physical Downlink Control Channel (PDCCH)/Enhanced Physical Downlink Control Channel (EPDCCH) on the bandwidth and the location of all the frequency resources available for the UE frequency resource allocation in the corresponding resource allocation indicating way according to the allocation unit of the UE frequency resource in the corresponding resource allocation indicating way, determining a bandwidth and a location of an uplink resource and/or a downlink resource actually allocated for the UE.
- [9] Preferably, the UE determining the resource allocation indicating way in the DCI of the first type search space includes determining, by the UE, the resource allocation indicating way in the DCI of the first type search space according to common signaling and initial access information transmitted by a base station, or, determining by the UE, the bandwidth and the location of all the frequency resources available for the UE frequency resource allocation in the DCI of the first type search space according to the common signaling and the initial access information transmitted by the base station, and determining the allocation unit of the UE frequency resource in the DCI of the first type search space through pre-configuration, or, determining, by the UE, the resource allocation indicating way in the DCI of the first type search space according to the pre-configuration.
- [10] Preferably, the UE determining the resource allocation indicating way in the DCI of the second type search space includes determining, by the UE, the resource allocation indicating way in the DCI of the second type search space according to higher layer signaling transmitted by the base station, or, determining by the UE, the bandwidth and the location of all the frequency resources available for the UE frequency resource allocation in the DCI of the second type search space according to higher layer signaling transmitted by the base station, and determining the allocation unit of the UE frequency resource in the DCI of the second type search space through the pre-configuration, or, for the DCI of a fallback transmission mode, determining, by the UE, the resource allocation indicating way in the DCI of the second type search space according to the common signaling or the initial access information transmitted by the base station, or determining the resource allocation indicating way in the DCI of a specific search space same as the resource allocation indicating way in the DCI of the

first type search space; for the DCI of a non-fallback transmission mode, determining, by the UE, the resource allocation indicating way in the DCI of the second type search space according to the higher layer signaling transmitted by the base station, or determining the bandwidth and the location of all the frequency resources available for the UE frequency resource allocation in the DCI of the second type search space according to the higher layer signaling transmitted by the base station, and determining the allocation unit of the UE frequency resource in the DCI of the second type search space through the pre-configuration, or, determining the resource allocation indicating way in the DCI of the specific search space same as the resource allocation indicating way in the DCI of the first type search space.

- [11] Preferably, when the UE does not determines the resource allocation indicating way in the DCI of the second type search space, the UE determines the resource allocation indicating way in the DCI of the specific search space same as the resource allocation indicating way in the DCI of the first type search space.
- [12] Preferably, the UE determining the resource allocation indicating way in the DCI of the first type search space and the resource allocation indicating way in the DCI of the second type search space includes receiving, by the UE, the common signaling or the initial access information transmitted by the base station, determining frequency information of two or more than two resource allocations, wherein the frequency information includes bandwidths and locations of all frequency resources for the resource allocations, using one of the two or more than two resource allocations for the first type search space according to the common signaling or the initial access information, taking a bandwidth and a location of all frequency resources for the resource allocation as the bandwidth and the location of all the frequency resources available for the UE frequency resource allocation in the DCI of the first type search space, selecting a resource allocation for the second type search space from the two or more than two resource allocations according to a preset regulation, taking a bandwidth and a location of all the frequency resources for the resource allocation as the bandwidth and the location of all the frequency resources available for the UE frequency resource allocation in the DCI of the second type search space.
- [13] Preferably, when the resource allocation indicating way for the first type search space and the resource allocation indicating way for the first type search space are determined, the UE determines the allocation unit of the UE frequency resource in the DCI of the first type search space and/or the second type search space according to the pre-configuration.
- [14] Preferably, the frequency information includes the allocation unit of the UE frequency resource, when the resource allocation indicating way for the first type search space and the resource allocation indicating way for the second type search

space are determined, the UE takes the allocation unit of the UE frequency resource used in the resource allocation for the first type search space as the allocation unit of the UE frequency resource in the DCI of the first type search space; and/or takes the allocation unit of the UE frequency resource used in the resource allocation for the second type search space as the allocation unit of the UE frequency resource in the DCI of the second type search space.

[15] Preferably, the UE determining the resource allocation indicating way in the DCI of the first type search space and the resource allocation indicating way in the DCI of the first type search space includes receiving, by the UE, the common signal or the initial access information transmitted by the base station, determining the frequency information of two or more resource allocations, wherein the frequency information includes the bandwidths and the locations of all frequency resource for the resource allocations, using, by the UE, one of the two or more than two resource allocations for the first type search space, and taking the bandwidth and the location of all the frequency resource of the resource allocation as the bandwidth and the location of all the frequency resource available for the UE frequency resource in the DCI of the first type search space, when the DCI of the UE specific search space is the DCI of the fallback transmission mode, determining the resource allocation indicating way in the DCI of the UE specific search space same as the resource allocation indicating way in the DCI of the first type search space; when the DCI of the UE specific search space is the DCI of the non-fallback transmission mode, select a resource allocation used for the second type search space from the two or more than two resource allocations according to the preset regulation, taking the bandwidth and the location of all the frequency resources for the resource allocation as the bandwidth and the location of all the frequency resources available for the UE frequency resource allocation in the DCI of the second type search space.

[16] Preferably, when the resource allocation indicating way in the DCI of the first type search space is determined, the UE determines the allocation unit of the UE frequency resource allocation in the DCI of the first type search space according to the pre-configuration, and/or, when the resource allocation indicating way in the DCI of the second type search space is determined and the DCI of the second type search space is the non-fallback transmission mode, the UE determines the allocation unit of the UE frequency resource allocation in the DCI of the second type search space according to the pre-configuration.

[17] Preferably, the frequency information includes the allocation unit of the UE frequency resource, when the resource allocation indicating way for the first type search space and the resource allocation indicating way for the second type search space are determined, the UE takes the allocation unit of the UE frequency resource

used in the resource allocation for the first type search type as the allocation unit of the UE frequency resource in the DCI of the first type search space; and/or, when the DCI of the second type search space is the non-fallback transmission mode, the UE takes the allocation unit of the UE frequency resource used in the resource allocation for the second type search type as the allocation unit of the UE frequency resource in the DCI of the second type search space.

- [18] Preferably, the preset regulation includes that the resource allocation the bandwidth of all the frequency resources of which is largest, and is smaller than or equal to the largest frequency bandwidth supported by the UE.
- [19] Preferably, before the UE determines the resource allocation indicating way in the DCI of the first type search space, further comprising: determining at least one sub-bandwidth indicated in the DCI of the first type search space; wherein the determining the resource allocation indicating way in the DCI of the first type search space comprises: determining a resource allocation indicating way in each sub-bandwidth indicated by the DCI of the first type search space, and/or, before the UE determines the resource allocation indicating way in the DCI of the second type search space, further comprising: determining at least one sub-bandwidth indicated in the DCI of the second type search space; wherein the determining the resource allocation indicating way in the DCI of the second type search space comprises: determining a resource allocation indicating way in each sub-bandwidth indicated by the DCI of the second type search space.
- [20] Preferably, before the UE determines the resource allocation indicating way in the DCI of the first type search space, further comprising: determining, by the UE, whether a one-step way or a two-step way is used for indicating a frequency resource in the DCI of the first type search space according to received system information indication or received high layer signaling configuration; when determining that the one-step way is used, directly performing the way that the UE determines the resource allocation indicating way in the DCI of the first type search space; when determining that the two-step way is used, before the UE determines the resource allocation indicating way in the DCI of the first type search space, determining the at least one sub-bandwidth indicated in the DCI of the first type search space, wherein the determining the resource allocation indicating way in the DCI of the first type search space comprises: determining a resource allocation indicating way in each sub-bandwidth indicated by the DCI of the first type search space, and/or, before the UE determines the resource allocation indicating way in the DCI of the second type search space, further comprising: determining, by the UE, whether a one-step way or a two-step way is used for indicating a frequency resource in the DCI of the second type search space according to received system information indication or high layer signaling con-

figuration; when determining that the one-step way is used, directly performing the way that the UE determines the resource allocation indicating way in the DCI of the second type search space; when determining that the two-step way is used, before the UE determines the resource allocation indicating way in the DCI of the second type search space, determining the at least one sub-bandwidth indicated in the DCI of the second type search space, wherein the determining the resource allocation indicating way in the DCI of the second type search space comprises: determining the resource allocation indicating way in each sub-bandwidth indicated in the DCI of the second type search space.

[21] Preferably, when the DCI of the second type search space is DCI with a backoff mode, before the UE determines the resource allocation indicating way in the DCI of the second type search space, further comprising: determining the at least one sub-bandwidth indicated in the DCI of the second type search space; wherein the determining the resource allocation indicating way in the DCI of the second type search space comprises: determining a resource allocation indicating way in each sub-bandwidth indicated in the DCI of the second type search space, and/or, when the DCI of the second type search space is DCI with a backoff mode, before the UE determines the resource allocation indicating way in the DCI of the second type search space, further comprising: determining, by the UE, whether a one-step way or a two-step way is used for indicating a frequency resource in the DCI of the second type search space according to received system information indication or received high layer signaling configuration; when determining that the one-step way is used, directly performing the way that the UE determines the resource allocation indicating way in the DCI of the second type search space; when determining that the two-step way is used, before the UE determines the resource allocation indicating way in the DCI of the second type search space, determining the at least one sub-bandwidth indicated in the DCI of the second type search space, wherein the determining the resource allocation indicating way in the DCI of the second type search space comprises: determining the resource allocation indicating way in each sub-bandwidth indicated in the DCI of the second type search space.

[22] Preferably, wherein the number of PRBs and locations of the PRBs included in the at least one sub-bandwidth in the DCI of the first type search space or in the DCI of the second type search space are preset, or are indicated by system information, or are determined according to system bandwidth.

[23] The present disclosure provides a resource scheduling apparatus, which includes an indicating way determining module, a blind detecting module and an actual resource determining module. The indicating way determining module is configured to determine a resource allocation indicating way in downlink control information (DCI)

of a first type search space and a resource allocation indicating way in the DCI of a second type search space, wherein the resource allocation indicating way includes an allocation unit of a UE frequency resource and a bandwidth and a location of all frequency resources available for UE frequency resource allocation. The blind detecting module is configured to in the first type search space and the second type search space, perform blind detection for Physical Downlink Control Channel (PDCCH)/Enhanced Physical Downlink Control Channel (EPDCCH) on the bandwidth and the location of all the frequency resources available for the UE frequency resource allocation in the corresponding resource allocation indicating way according to the allocation unit of the UE frequency resource in the corresponding resource allocation indicating way. And the actual resource determining module is configured to determine a bandwidth and a location of an uplink resource and/or a downlink resource actually allocated for the UE.

- [24] It can be seen from above that, according to the present disclosure, a UE determines a resource allocation indicating way in DCI of a first type search space and a resource allocation indicating way in DCI of a second type search space, wherein the resource allocation indicating way includes an allocation unit of a UE frequency resource and a bandwidth and a location of all frequency resources available for UE frequency resource allocation; in the first type search space and the second type search space, the UE performs blind detection for PDCCH/EPDCCH on the bandwidth and the location of all the frequency resources available for the UE frequency resource allocation in the corresponding resource allocation indicating way according to the allocation unit of the UE frequency resource in the corresponding resource allocation indicating way, determining a bandwidth and a location of an uplink resource and/or a downlink resource actually allocated for the UE. According to the technical solution above, the resource allocation indicating way is firstly determined, and then the blind detection is performed for the PDCCH/EPDCCH according to the resource allocation indicating way, so that when the UE cannot support the entire system bandwidth, the UE can still determine the range and the unit for the blind detection according to the resource allocation indicating way, and can appropriately determine the uplink resource and the downlink resource allocated by the base station.

Advantageous Effects of Invention

- [25] The present disclosure is to provide an apparatus and method for resource scheduling. Thus, it is possible to provide an apparatus and method for resource scheduling in a condition that a terminal in a wireless communication system cannot support the entire system bandwidth.

Brief Description of Drawings

- [26] FIG. 1 is a schematic diagram illustrating a structure of a frame in a frequency division duplex (FDD) system;
- [27] FIG. 2 is a schematic diagram illustrating a structure of a subframe in a LTE system;
- [28] FIG. 3 is a basic flowchart illustrating an uplink and downlink resource scheduling method according to the present disclosure;
- [29] FIG. 4 is a schematic diagram illustrating a structure of an uplink and downlink resource scheduling apparatus according to the present disclosure; and
- [30] FIG. 5 is an example configuration of a terminal in a wireless communication system according to an exemplary embodiment of the disclosure.
- [31] Throughout the drawings, it should be noted that like reference numbers are used to depict the same or similar elements, features, and structures.

Best Mode for Carrying out the Invention

- [32] In order to make the object, technical solution and merits of the present invention clearer, the present invention will be illustrated in detail hereinafter with reference to the accompanying drawings and specific examples.
- [33] In a Long Term Evolution Advanced (LTE-A) system, a length of each radio frame is 10ms, and the radio frame is equally divided into 10 subframes. A downlink Transmission Time Interval (TTI) is defined in a subframe. FIG. 1 is a schematic diagram illustrating a structure of a frame in a Frequency Division Duplex (FDD) system. As shown in FIG. 1, each downlink frame includes two slots, for a normal Cyclic Prefix (CP) length, each slot includes 7 Orthogonal Frequency Division Multiplexing (OFDM) symbols, for an extended CP length, each slot PDCCH/EPDCCH includes 6 OFDM symbols.
- [34] FIG. 2 is a schematic diagram illustrating a structure of a subframe in a LTE system. As shown in FIG. 2, first n OFDM symbols, $n=1, 2$ or 3 , are used for downlink control information transmission, which includes a Physical Downlink Control Channel (PDCCH) and other control information; additional OFDM symbols are used for Physical Downlink Shared Channel (PDSCH) transmission. A basic granularity for a resource allocation is a Physical Resource Block (PRB) pair, and a PRB includes 12 successive subcarriers in frequency, and corresponds to a slot in time. Two PRBs in two slots in a same subframe in a frame are referred to as a PRB pair. In each PRB pair, each resource element (RE) is a minimum unit of time-frequency resources, i.e., each RE is a subcarrier in frequency, and is an OFDM symbol in time. The RE can be used for different functions, e.g., a part of REs can be respectively used for Cell-specific Reference Signal (CRS) transmission, Demodulation Reference Signal (DMRS) transmission, Channel State Information-Reference Signal (CSI-RS) transmission, PDCCH transmission, PDSCH transmission, etc.

- [35] In LTE system, the PDSCH transmission and the PUSCH transmission are scheduled through a PDCCH or an Enhanced Physical Downlink Control Channel (EPDCCH), where resources for the PDSCH transmission and the PUSCH transmission are allocated through resource allocation signaling in Downlink Control Information (DCI) carried in the PDCCH/EPDCCH, a maximum resource allocated for the PDSCH transmission and the PUSCH transmission is all PRB pairs in the entire system bandwidth, a minimum resource allocated for the PDSCH transmission and the PUSCH transmission is a PRB pair. The number of bits of the resource allocation signaling in the PDCCH/EPDCCH is calculated according to the number of the PRB pairs in the entire system bandwidth. For example, when the system bandwidth is 10MHz, the number of the PRB pairs is equal to 50, and the number of the bits of the resource allocation signaling used in the PDCCH/EPDCCH is calculated according to different resource allocation methods regarding that the number of the PRB pairs is equal to 50.
- [36] In LTE system, for the PDCCH transmission, a common search space and a UE specific search space are defined. All UEs can perform demodulation and decoding in the common search space, and only specific UEs can perform demodulation and decoding in the UE specific search space. A process of tracking the PDCCH is performed by trying to perform demodulation and decoding (i.e., blind detection) for common search spaces of all candidate PDCCHs and a UE specific search common set, performing check through Cyclic Redundancy Check (CRC) scrambled by a Radio Network Temporary Indicator (RNTI) (e.g., C-RNTI), and searching out the PDCCH scheduled by a base station. The number of candidate PDCCHs of the common search space and UE specific search space is as shown in Table 1. The common search spaces include search spaces aggregation levels of which are 4 and 8 Control Channel Elements (CCE). The UE specific search spaces include search spaces aggregation levels of which are 1, 2, 4 and 8 Control Channel Elements (CCE). For each transmission mode, the UE tracks two different sizes of DCI formats. Thus, for the common search space, the UE tracks $2 * (4+2) = 12$ candidate PDCCHs; for the UE specific search space, the UE tracks $2 * (6+6+2+2) = 32$ candidate PDCCHs, where one type is a fallback DCI format, e.g., DCI format 1A, another type is a normal DCI format, e.g., DCI format 1B/1D/2/2A. The scheduling described above is PDSCH scheduling. Further, the scheduling described below is PUSCH scheduling. The PUSCH may be scheduled through the PDCCH in the common search space, or may be scheduled through the PDCCH in the UE specific search space.

[37]

Table 1

Search Space $S_k^{(L)}$			The number of candidate PDCCHs $M^{(L)}$
Type	Aggregation Level L	Size [the number of CCEs]	
UE Specific	1	6	6
	2	12	6
	4	8	2
	8	16	2
Common	4	16	4
	8	16	2

[38] The UE specific search space is associated with a user's RNTI and a subframe index, i.e., after the user's RNTI of the UE is determined, the location of the CCEs occupied by the UE in the UE specific search space in the specific subframe is determined.

[39] In LTE system, the UE capability may support the entire system bandwidth. Thus, when determining uplink data resources and downlink data resources actually allocated, the UE may perform blind detection in the entire frequency range in the common search space and the UE specific search space. However, in a new radio (NR) access technology, as the frequency bandwidth is largely improved, the system bandwidth is largely improved accordingly. However, some UEs may not support such large system bandwidth, and different UEs may support different maximum system bandwidths. According to the present disclosure, uplink and downlink data scheduling methods are researched in conditions that the supported system bandwidths are different.

[40] In order to implement an intention of the present disclosure, the present disclosure provides a resource scheduling method. As shown in FIG. 3, the method includes procedures as follows. Herein, the UE may be referred as 'a terminal' and so on.

[41] At block 301, a UE determines a resource allocation indicating way in DCI of at least one search space (referred to as a first type search space herein, e.g., a common search space, this type search space is used to schedule System Information (SIBs), a PDSCH for random access (Msg2), etc.) and a resource allocation indicating way in DCI of another search space (referred to as a second type search space, e.g., a UE specific search space, a UE-group search space).

[42] The resource allocation indication way includes a frequency resource allocation unit of the UE (e.g., referred to as a Resource Block Group (RBG), and a sub-carrier space) and bandwidth and locations of all frequency resources available for frequency resource allocation of the UE, e.g., the location of the frequency resource refers to a

central frequency of the frequency resource.

[43] At block 302, in the first type search space and the second type search space, the UE performs blind detection for PDCCH/EPDCCH according to the corresponding resource allocation indicating way, and obtains a bandwidth and a location of an uplink data resource and/or a downlink data resource actually allocated for the UE.

[44] When the blind detection for the PDCCH/EPDCCH is performed, the UE performs the blind detection for the PDCCH/EPDCCH on the bandwidth and the location of all the frequency resources available for the UE resource allocation in the first type search space or the second type search space according to the determined allocation unit of the UE frequency resource. After the blind detection is performed, a way same as an existing way may be used during the processing of determining a resource actually allocated, which is not repeatedly described.

[45] Technical solutions of the present disclosure are further described in detail according to preferable embodiments as follows.

[46] Embodiment 1

[47] In this embodiment, they are respectively described about how to determine the resource allocation indicating way in the DCI of the first type search space and how to determine the resource allocation indicating way in the DCI of the second type search space, so as to determine a DCI detection way in a corresponding search space.

[48] How to determine the resource allocation way in the DCI of the first type search space is firstly described.

[49] First Way:

[50] For the bandwidth and the location of all the frequency resources available for the UE frequency resource allocation in the resource allocation indicating way, a determining way includes that the UE receives the common signaling (e.g., MIB, system information) or initial access information transmitted by a base station, obtains the bandwidth and the location of all the frequency resources available for the resource allocation in the DCI of the first type search space by receiving the common signaling or the initial access information. For example, according to the received common signaling or the common initial access information, the UE obtains that the system bandwidth available for the DCI of the first type search space is 110 PRBs, or 75 PRBs, or 50 PRBs, or 25 PRBs, or 15 PRBs, or 6 PRBs, the location of these PRBs may be deduced according to the locations of the synchronization signals, and the bandwidth of each PRB is 180kHz.

[51] For the allocation unit of the UE frequency resource in the resource allocation indicating way, there are two determining ways. One determining way is same as that described above, i.e., the UE receives the common signaling or the initial access information, and determines the allocation unit of the UE frequency resource through the

common signaling or the initial access information; another determining way includes that the allocation unit of the UE frequency resource is determined according to pre-configuration, e.g., according to a specification; another determining way includes that the allocation unit of the UE frequency resource is determined according to the bandwidth of all the frequency resources for the resource allocation in the DCI of the first type search space.

[52] The UE performs the blind detection for the PDCCH of the first type search space according to the resource allocation indicating way determined above, obtains the number and the location of the uplink resource and the number of the location of the downlink resource actually allocated for the UE.

[53] Second Way:

[54] Another determining way includes that the UE determines the resource allocation indicating way in the first type search space according to pre-configuration (e.g., a specification), in particular, includes a bandwidth (referred to as a common system bandwidth) and a location of all frequency resources in the first type search space, and the allocation unit of the UE frequency resource in the first type search space. For example, the system bandwidth available for the first type search space is preset as 110 PRBs according to the specification, the location of the 110 PRBs may be deduced according to the synchronization signal, and the bandwidth of each PRB is 180kHz, and the allocation unit of the UE frequency resource in the DCI of the first type search space is further preset as 2PRBs pairs according to the specification. The UE performs the blind detection according to the information, and obtain the bandwidth and the location of the uplink resource and the bandwidth and the location of the downlink resource actually allocated for the UE. The number of the blind detections performed for the PDCCH/EPDCCH of the first type search space by the UE is obtained by receiving the common signaling and the initial access information, or is preset by the specification. A PDCCH/EPDCCH format of the PDCCH/EPDCCH which is blindly detected in the first type search space (including the number of bits included in the PDCCH/EPDCCH) is indicated by the common signaling, or is obtained through the initial access information, or is preset through a specification.

[55] The resource allocation indicating way in the DCI of the second type search space is described below, and the second type search space may be used for the UE specific search space, or may be used for the UE-group search space.

[56] First Way:

[57] For the bandwidth and the location of all the frequency resources available for the UE frequency resource allocation in the resource allocation indicating way, a first determining way includes that the UE receives higher layer signaling transmitted by the base station, obtains the bandwidth (which may be referred to as the UE specific

system bandwidth) and the location of all the frequency resources available for the resource allocation in the DCI of the second search space. For example, the configuration information through the higher layer signaling indicates that the system bandwidth available for the DCI of the second type search space is 110 PRBs, the configuration information through the higher layer signaling further indicates the location of these 110 PRBs, and the bandwidth of each PRB is 180 kHz.

[58] For the allocation unit of the UE frequency resource in the resource allocation indicating way, there are two determining ways. One determining way is same as that described above, i.e., the UE receives the higher layer signaling transmitted by the base station, and determines the allocation unit of the UE frequency resource through indication of the higher layer signaling; another determining way includes that the allocation unit of the UE frequency resource is determined according to the pre-configuration, e.g., according to a specification; another determining way includes that the allocation unit of the frequency resource is determined according to the bandwidth of all the frequency resources for the resource allocation in the DCI of the second type search space.

[59] The UE performs the blind detection for the PDCCH of the second type search space according to the determined resource allocation indicating way, obtains the bandwidth and the location of the uplink resource actually allocated for the UE and the bandwidth and the location of the downlink resource actually allocated for the UE. The number of the blind detections performed for the PDCCH/EPDCCH of the second type search space by UE is configured through the higher layer signaling, or is preset through the specification. The PDCCH/EPDCCH format of the PDCCH/EPDCCH which is blindly detected by the UE in the second type search space (including the number of bits included in the PDCCH/EPDCCH) is configured by the higher layer signaling, or is preset by the specification.

[60] Second Way:

[61] The second type search space includes two configuration transmission modes, one is referred to as a fallback transmission mode (e.g., a DCI format 1A), and the other one is referred to as a non-fallback transmission mode (e.g., a DCI format 1D, a DCI format 2, a DCI format 2A).

[62] For the fallback transmission mode, the UE directly takes the resource allocation indicating way in the DCI of the first type search space as the resource allocation indicating way in the DCI of the specific search space, i.e., the resource allocation indicating way in the DCI of the first type search space and the DCI of the second type search space are same.

[63] Since the second type search space includes the fallback transmission mode and the non-fallback transmission mode, the second type search space is the UE specific search

space, and further includes the UE-group search space, the UE-group search space is for a group of UEs, e.g., a power control command is transmitted through the UE-group search space, or some indications are transmitted through the UE-group search space, or some data may be scheduled, e.g., for system reconfiguration, the data transmitted in the search space is small, in order to reduce the number of times of blind detection, the fallback transmission mode in the UE specific search space and the UE-group search space may use a same DCI format as far as possible. Resource allocation indicating ways for these search spaces are described as below.

[64] For the fallback transmission mode, the transmission mode is mainly used for system reconfiguration, the scheduled data is small, in addition, the mode requires high reliability for DCI transmission, thus, the bandwidth of the resource may be small, and the number of bits for resource allocation is small, however, the central frequency may be same, when the UE detects simultaneously the two transmission modes, implementation complexity is small, and a resource allocation unit (i.e., RBG) may be same with the non-fallback transmission mode. For the non-fallback mode, the frequency resource allocated for the UE is greatly large, when the allocation unit of the frequency resource same with the fallback transmission mode is used, the number of the bits of the frequency resource allocation indication is greatly large, thus, the frequency resource allocation unit of the UE for the non-fallback transmission mode may be greatly large, thus, bits used for the frequency resource allocation indication may be saved. Time for switching between different search spaces may be reduced because the central frequency is same.

[65] In addition, since the UE receives a UE-group common command, e.g., a UE-group power control command, the UE-group power control command is received every time slot, since the number of bits of the UE-group DCI is small, in order to reduce the complexity that the UE blindly detects the DCI, the number of bits of the DCI for the fallback transmission mode may be same as that of the UE-group DCI. Thus, the fallback transmission mode may use the UE specific search space.

[66] Thus, the bandwidth of the frequency resource and the frequency resource allocation unit of the UE for the fallback transmission mode may be determined independently from the bandwidth of the frequency resource and the frequency resource allocation unit of the UE for the non-fallback transmission mode, e.g., configuration is performed through independent higher layer signaling. The number of bits of DCI of the UE-group search space is similar as that of the UE specific search space, and only one search space may be used, so as to further reduce the number of times of blind detection.

[67] For the non-fallback transmission mode, the determining way for the bandwidth and the location of all the frequency resources available for the UE frequency resource al-

location in the resource allocation indicating way includes that: the UE receives the higher layer signaling transmitted by the base station, obtains the bandwidth (referred as to the system bandwidth) and the location of all the frequency resources available for the resource allocation in the DCI of the second type search space through the indication of the higher layer signaling, e.g., the configuration information through the higher layer signaling indicates that the system bandwidth available for the DCI of the second type search space is 110 PRBs, the configuration information through the higher layer signaling further indicates the location of the 110 PRBs, and the bandwidth of each PRB is 180 kHz. The allocation unit of the UE frequency resource in the resource allocation indicating way may be determined according to the higher layer signaling transmitted by the base station, or may be determined according to the pre-configuration (e.g., may be preset according to the specification).

[68] The UE perform the blind detection for the PDCCH of the second type search space according to the determined resource allocation indicating way, obtains the bandwidth and the location of the uplink resource actually allocated for the UE and the bandwidth and the location of the downlink resource actually allocated for the UE.

[69] Third Way:

[70] In this way, a resource allocation way for the DCI of the second type search space may be determined same as that for the first type search space.

[71] Alternatively, when the resource allocation indicating way for the DCI of the second type search space is not determined according to a preset way, e.g., when the UE does not receive the higher layer signaling used for indicating the resource allocation indicating way in the DCI of the second search space, the resource allocation indicating way in the DCI of the second type search space is determined same as the resource allocation indicating way in the DCI of the first type search space.

[72] During the processing above, the resource allocation indicating way in the DCI of the first type search space and the resource allocation indicating way in the DCI of the second type search space are basically independent from each other. Two ways are provided below, in which the resource allocation indicating way in the DCI of the first type search space and the resource allocation indicating way in the DCI of the second type search space are respectively indicated through the common signaling or the initial access information indication.

[73] First Way:

[74] The UE receives the common signaling or the initial access information transmitted from the base station to the UE, and obtains bandwidths (referred as to system bandwidth) and locations of all frequency resources for two or more than two resource allocations. A bandwidth (referred as to system bandwidth) and a location of all frequency resources for a resource allocation are used for the resource allocation in the

DCI of the first type search space, and are taken respectively as the bandwidth and the location of all the frequency resources available for the UE frequency resource allocation in the DCI of the first type search space. Which resource allocation is used for the DCI of the first type search space may be determined through the common signaling or the initial access information, or may be determined through the pre-configuration. For the resource allocation in the DCI of the second type search space, a resource allocation may be selected from the two or more than two resource allocations obtained by using the common signaling or the initial access information according to a preset regulation, and the bandwidth and the location of all the frequency resources for the resource allocation is taken as the bandwidth and the location of all the frequency resources available for the UE frequency resource allocation in the second type search space. The detail preset regulation may be set according to requirements, e.g., the preset regulation may include that the resource allocation the bandwidth of all the frequency resources of which is largest, and is smaller than or equal to a maximum frequency bandwidth supported by the UE.

[75] The allocation unit of the UE frequency resource in the DCI of the first type search space and the allocation unit of the UE frequency resource in the DCI of the second type search space may be determined according to the pre-configuration (e.g., a fixed allocation unit of the UE frequency resource is preset in a specification), or may be determined according to the common signaling or the initial access information above. In particular, when the bandwidths (referred as to the system bandwidth) and the locations of all the frequency resources for the two or more than two resource allocations are obtained from the common signaling or the initial access information, the allocation unit of the UE frequency resource in the two or more than two resource allocations is indicated at the same time. Based on this, for the resource allocation used for the DCI of the first type search space, the allocation unit of the UE frequency resource for the resource allocation is taken as the allocation unit of the UE frequency resource in the DCI of the first type search space; for the resource allocation used for the DCI of the second type search space, the allocation unit of the UE frequency resource for the resource allocation is taken as the allocation unit of the UE frequency resource in the DCI of the second type search space.

[76] It can be seen from above that, the frequency information of two or more than two resource allocation is obtained according to the indication of the common signaling or the initial access information, the frequency information may include the bandwidth and the location of all the frequency resources, preferably, further includes the allocation unit of the UE frequency resource.

[77] Second Way:

[78] The UE receives the common signaling and the initial access information transmitted

from a base station to the UE, obtains the frequency information of the two or more resource allocations through the common signaling and the initial access information. The frequency information of the resource allocation is same as that in the first way above, which is not described repeatedly herein. For the resource allocation indicating way in the DCI of the first type search space, the determining way is same as that for the first type search space in the first way above, which is not described repeatedly herein.

- [79] For the second type search space, the DCI includes two configuration transmission modes, one is referred to as a fallback transmission mode (e.g., DCI format 1A), and the other is referred to as a non-fallback transmission mode (e.g., DCI format 1D, DCI format 2, DCI format 2A).
- [80] For the fallback transmission mode, the resource allocation indicating way in the DCI of the second type search space is determined same as the resource allocation indicating way in the DCI of the first search space.
- [81] For the non-fallback transmission mode, the resource allocation indicating way is determined same as the resource allocation indicating way in the DCI of the second search space in the first way above, which is not repeatedly described herein.
- [82] According to the multiple ways described above, the resource allocation indicating way in the DCI of the first type search space and the second type search space can be determined. Next, according to the determined resource allocation indicating ways, the DCI detection way is determined, i.e., in the first type search space and the second type search space, the PDCCH/EPDCCH is blindly detected according to the corresponding resource allocation indicating way. Lastly, according to a blind detection result, the bandwidth and the location of the uplink and/or downlink resources actually allocated for the UE are determined.
- [83] Embodiment 2
- [84] There are two methods for indicating a frequency resource in DCI. A method includes performing indication through one step, i.e., the number and locations of PRBs in allocated system bandwidth or configured bandwidth are directly indicated, Another method includes performing indication through two steps together, in a first step, a sub-bandwidth (also referred to as band part (BP)) in the system bandwidth or the configured bandwidth is indicated, in a second step, the number and the locations of the PRBs in the BP indicated in the first step are indicated. For the UE supporting limited bandwidth, by using the method that two steps are performed together to indicate the frequency resource can save information bit overhead. The one or more sub-bandwidths may be indicated in the first step, when multiple sub-bandwidths are indicated, the number and the locations of the PRBs in each BP are indicated in the second step.

- [85] It is described below whether a one-step way or a two-step way is used for the resource allocation in the DCI of the first type search space or the DCI of the second type search space.
- [86] There are some methods for the DCI of the first type search space.
- [87] Method 1:
- [88] A one-step indicating way is used for allocating a frequency resource for scheduling a PUSCH or a PDSCH in the DCI of the first type search space. Since different UEs supports different bandwidth capabilities, and a base station may not know a bandwidth capability supported by a UE just accessing a system, it is not required for the UE to use the two-step indicating way. An allocation unit of the frequency resource of the UE and bandwidths and locations of all frequency resources available for frequency resource allocation of the UE may be obtained through a method in embodiment 1.
- [89] Actually, the processing in the method is to independently perform a corresponding processing way in embodiment 1 above.
- [90] Method 2:
- [91] A two-step indicating way is used for allocating a frequency resource for scheduling a PUSCH or a PDSCH in the DCI of the first type search space. In a first step, at least one BP indicated by the DCI is determined, wherein the number of the PRBs included in the BP is preset through a specification, or is indicated through system information (the system information herein includes a main system block (MIB) or a system information block (SIB)). The number of the PRBs occupied by each BP in the first step and locations of the PRBs may be preset through a specification, or is indicated through system information (the system information herein includes a MIB or a SIB), or is deduced through system bandwidth (or determined according to minimum bandwidth). In a second step, a resource allocation indicating way for each BP in the first step is determined, wherein an allocation unit of a frequency resource of the UE in each BP and bandwidths and locations of all frequency resources available for frequency resource allocation of the UE may be obtained through the method in embodiment 1.
- [92] The processing in the method is to increase sub-bandwidth indicating processing based on the processing above in embodiment 1, accordingly, a resource allocation indicating way in the DCI of the first type search space in embodiment 1 is a resource allocation indicating way in a corresponding sub-bandwidth.
- [93] Method 3:
- [94] One of the one-step indicating way and the two-step indicating way is used for allocating a frequency resource for scheduling a PUSCH or a PDSCH in the DCI of the first type search space through system information indication or by high layer signaling

configuration. When the two-step indicating way is used, in a first step, at least one BP indicated in the DCI is determined. The number of the PRBs included in the BP is preset in specification, or is indicated by the system information (the system information herein includes a MIB or a SIB), or is deduced according to the system bandwidth. In a second step, a resource allocation indicating way in each BP in the first step is determined, wherein an allocation unit of a frequency resource of the UE in each BP and bandwidths and locations of all frequency resources available for frequency resource allocation of the UE may be obtained through the method in embodiment 1.

- [95] For the first type search space, the UE may preset the BP used for PDSCH transmission of the first type search space through specifications, or determines the BP used for PDSCH transmission of the first type search space according to system bandwidth, a system frequency band range, etc., when there are multiple BPs, information in MIB indicates which BP is scheduled for the PDSCH transmission by the DCI of the first type search space, or the BP scheduled for the PDSCH transmission by the DCI of the first type search space is the BP where the PBCH and the synchronization signaling is located.
- [96] For the first type search space, the BP for DCI transmission may be the BP where the PBCH and the synchronization signaling is located, or may be information indication in the MIB.
- [97] For the first type search space, the BP for DCI transmission may be in a same BP with the transmission of the PDSCH scheduled by the DCI of the first type search space, thus, the BP where the PDSCH is located may be not directly indicated in the DCI, implementation according to this method is simple; when the BP for DCI transmission may be not in the same BP with the transmission of the PDSCH scheduled by the DCI of the first type search space, the BP where the PDSCH is located may be directly indicated in the DCI, according to this method, frequency diversity gain may be improved through scheduling according to performance of different BPs.
- [98] There are some methods for the DCI of the second type search space.
- [99] Method 1:
- [100] A two-step indicating way is used for allocating a frequency resource for scheduling a PUSCH or a PDSCH in the DCI of the second type search space. In a first step, at least one BP indicated by the DCI is determined, wherein the number of the PRBs included in the BP is preset through a specification, or is indicated through system information (the system information herein includes a main system block (MIB) or a system information block (SIB)), or is deduced through system bandwidth, or is configured through high layer signaling. In a second step, a resource allocation in-

dicating way in each BP in the first step is determined, wherein an allocation unit of a frequency resource of the UE in each BP and bandwidths and locations of all frequency resources available for frequency resource allocation of the UE may be obtained through the method in embodiment 1.

[101] The processing in the method is to increase sub-bandwidth indicating processing based on the processing above in embodiment 1, accordingly, a resource allocation indicating way in the DCI of the second type search space in embodiment 1 is a resource allocation indicating way in a corresponding sub-bandwidth.

[102] For the second search space, the UE may receive higher layer signaling to determine to configure at least one BP for the UE, when multiple BPs are configured for the UE, by receiving physical layer signaling or Media Access Control layer signaling, it is determined which configured BP is activated, e.g., the UE is configured with three BPs, BP1, BP2, BP3, since bandwidth processing of the UE is limited, the UE may activate one of the BP1, BP2, BP3 through the physical layer signaling or the Media Access Control layer signaling.

[103] Method 2:

[104] One of the one-step indicating way and the two-step indicating way is used for allocating a frequency resource for scheduling a PUSCH or a PDSCH in the DCI of the second type search space through high layer signaling configuration. When the two-step indicating way is used, in a first step, at least one BP indicated in the DCI is determined. The number of the PRBs included in the BP is preset in specification, or is indicated by the system information (the system information herein includes a MIB or a SIB), or is deduced according to the system bandwidth, or is configured through high layer signaling. In a second step, a resource allocation indicating way in each BP in the first step is determined, wherein an allocation unit of a frequency resource of the UE in each BP and bandwidths and locations of all frequency resources available for frequency resource allocation of the UE may be obtained through the method in embodiment 1. When the one-step way is used, an allocation unit of a frequency resource of the UE in each BP and bandwidths and locations of all frequency resources available for frequency resource allocation of the UE may be obtained through the method in embodiment 1.

[105] Method 3:

[106] For the second type search space, there are two kinds of transmission configuration mode for the DCI, one may be referred to as backoff transmission mode (e.g., DCI format 1A), the other one may be referred to as non-backoff transmission mode (e.g., DCI format 1D, DCI format 2, DCI format 2A, etc.).

[107] For the backoff transmission mode, the two-step indicating way is used for allocating a frequency resource for scheduling a PUSCH or a PDSCH in the DCI of the second

type search space. In a first step, at least one BP indicated by the DCI is determined, wherein the number of the PRBs included in the BP is preset through a specification, or is indicated through system information (the system information herein includes a MIB or a SIB), or is deduced through system bandwidth, or is configured through high layer signaling. In a second step, a resource allocation indicating way for each BP in the first step is determined, wherein an allocation unit of a frequency resource of the UE in each BP and bandwidths and locations of all frequency resources available for frequency resource allocation of the UE may be obtained through the method in embodiment 1.

[108] For the non-falloff transmission mode, one of the one-step indicating way and the two-step indicating way is used for allocating a frequency resource for scheduling a PUSCH or a PDSCH in the DCI of the second type search space through high layer signaling configuration. When the two-step indicating way is used, in a first step, at least one BP indicated in the DCI is determined, wherein the number of the PRBs included in the BP is preset in specification, or is indicated by the system information (the system information herein includes a MIB or a SIB), or is deduced according to the system bandwidth, or is configured through high layer signaling. In a second step, a resource allocation indicating way in each BP in the first step is determined, wherein an allocation unit of a frequency resource of the UE in each BP and bandwidths and locations of all frequency resources available for frequency resource allocation of the UE may be obtained through the method in embodiment 1. When the one-step way is used, an allocation unit of a frequency resource of the UE in each BP and bandwidths and locations of all frequency resources available for frequency resource allocation of the UE may be obtained through the method in embodiment 1.

[109] The detail implementation for the resource scheduling method according to the present disclosure has been described above. The present disclosure further provides a resource scheduling apparatus. FIG. 4 is a schematic diagram illustrating a basic structure of the apparatus. As shown in FIG. 4, the apparatus includes: an indicating way determining module 410, a blind detecting module 420 and an actual resource determining module 430.

[110] The indicating way determining module 410 is configured to determine a resource allocation indicating way in DCI of a first type search space and a resource allocation indicating way in the DCI of a second type search space, wherein the resource allocation indicating way comprises an allocation unit of a UE frequency resource and a bandwidth and a location of all frequency resources available for UE frequency resource allocation. The blind detecting module 420 is configured to in the first type search space and the second type search space, perform blind detection for PDCCH/EPDCCH on the bandwidth and the location of all the frequency resources available

for the UE frequency resource allocation in the corresponding resource allocation indicating way according to the allocation unit of the UE frequency resource in the corresponding resource allocation indicating way. And the actual resource determining module 430 is configured to determine a bandwidth and a location of an uplink resource and/or a downlink resource actually allocated for the UE.

[111] FIG. 5 illustrates an example configuration of a terminal in a wireless communication system according to an exemplary embodiment of the disclosure. FIG. 5 illustrates an example of a configuration of the apparatus of Fig. 4 or the UE. Hereinafter, the term "unit" or the term ending with the suffix "-er" or "-or" refer to a unit for processing at least one function or operation and these terms may be implemented by using hardware or software or a combination of hardware and software. Referring to FIG. 5, the terminal includes a communication unit 510, a storage 520, and a controller 530.

[112] The communication unit 510 performs functions for transmitting and receiving signals via a radio channel. For example, the communication unit 510 performs a function of converting between a baseband signal and a bit string according to a physical layer standard of a system. For example, when transmitting data, the communication unit 510 generates complex symbols by encoding and modulating a transmission bit string. In addition, when receiving data, the communication unit 510 restores a reception bit string by demodulating and decoding a baseband signal. In addition, the communication unit 510 up-converts a baseband signal into an RF band signal and then transmit the RF band signal through an antenna, and down-converts an RF band signal received through the antenna into a baseband signal. For example, the communication unit 510 may include a transmission filter, a reception filter, an amplifier, a mixer, an oscillator, a DAC, an ADC, or the like.

[113] The communication unit 510 transmits and receives signals as described above. Accordingly, the communication unit 510 may be referred to as a transmission interface, a reception interface, a transmission and reception interface, a transmitter, a receiver or a transceiver. In addition, in the following description, transmitting and receiving performed through a radio channel may include processing by the communication unit 510 as described above.

[114] The storage 520 stores data such as a basic program for the operation of the terminal, an application program, setting information, or the like. The storage 520 may be configured by a volatile memory, a nonvolatile memory, or a combination of a volatile memory and a nonvolatile memory. In addition, the storage 520 provides stored data in response to a request of the controller 530.

[115] The controller 530 controls overall operations of the terminal. For example, the controller 530 transmits and receives signals through the communication unit 510. In addition, the controller 530 records and reads data on and from the storage 520. To

achieve this, the controller 530 may include at least one processor or microprocessor or may be a part of the processor. In addition, a part of the communication unit 510 and the controller 530 may be referred to as a communication processor (CP). In particular, the controller 530 may perform D2D signaling for positioning of the terminal and may measure information related to the D2D signal according to various exemplary embodiments which will be described below. For example, the controller 530 may control the terminal to perform a procedure according to various exemplary embodiments which will be described below. The controller 530 may comprise at least one of the indicating way determining module 410, a blind detecting module 420 and an actual resource determining module 430.

[116] The foregoing is only preferred examples of the present invention and is not used to limit the protection scope of the present invention. Any modification, equivalent substitution and improvement without departing from the spirit and principle of the present invention are within the protection scope of the present invention.

Claims

- [Claim 1] A method for resource scheduling of a terminal in a wireless communication system, the method comprising:
determining, by the terminal, a resource allocation indicating way in downlink control information (DCI) of a first type search space and a resource allocation indicating way in DCI of a second type search space, wherein the resource allocation indicating way comprises an allocation unit of a terminal frequency resource and a bandwidth and a location of all frequency resources available for terminal frequency resource allocation; and
in the first type search space and the second type search space, performing, by the terminal, blind detection for physical downlink control channel (PDCCH)/enhanced physical downlink control channel (EPDCCH) on the bandwidth and the location of all the frequency resources available for the terminal frequency resource allocation in the corresponding resource allocation indicating way according to the allocation unit of the terminal frequency resource in the corresponding resource allocation indicating way, determining a bandwidth and a location of an uplink resource and/or a downlink resource actually allocated for the terminal.
- [Claim 2] The method of claim 1, wherein determining the resource allocation indicating way in the DCI of the first type search space comprises:
determining, by the terminal, the resource allocation indicating way in the DCI of the first type search space according to common signaling and initial access information transmitted by a base station; or,
determining by the terminal, the bandwidth and the location of all the frequency resources available for the terminal frequency resource allocation in the DCI of the first type search space according to the common signaling and the initial access information transmitted by the base station, and determining the allocation unit of the terminal frequency resource in the DCI of the first type search space through pre-configuration; or,
determining, by the terminal, the resource allocation indicating way in the DCI of the first type search space according to the pre-configuration.
- [Claim 3] The method of claim 1, wherein determining the resource allocation indicating way in the DCI of the second type search space comprises:

determining, by the terminal, the resource allocation indicating way in the DCI of the second type search space according to higher layer signaling transmitted by the base station; or,
determining by the terminal, the bandwidth and the location of all the frequency resources available for the terminal frequency resource allocation in the DCI of the second type search space according to higher layer signaling transmitted by the base station, and determining the allocation unit of the terminal frequency resource in the DCI of the second type search space through the pre-configuration; or,
for the DCI of a fallback transmission mode, determining, by the terminal, the resource allocation indicating way in the DCI of the second type search space according to the common signaling or the initial access information transmitted by the base station, or determining the resource allocation indicating way in the DCI of a specific search space same as the resource allocation indicating way in the DCI of the first type search space; for the DCI of a non-fallback transmission mode, determining, by the terminal, the resource allocation indicating way in the DCI of the second type search space according to the higher layer signaling transmitted by the base station, or determining the bandwidth and the location of all the frequency resources available for the terminal frequency resource allocation in the DCI of the second type search space according to the higher layer signaling transmitted by the base station, and determining the allocation unit of the terminal frequency resource in the DCI of the second type search space through the pre-configuration; or,
determining the resource allocation indicating way in the DCI of the specific search space same as the resource allocation indicating way in the DCI of the first type search space.

[Claim 4] The method of claim 1 or 3, wherein when the terminal does not determine the resource allocation indicating way in the DCI of the second type search space, the terminal determines the resource allocation indicating way in the DCI of the specific search space same as the resource allocation indicating way in the DCI of the first type search space.

[Claim 5] The method of claim 1, wherein determining the resource allocation indicating way in the DCI of the first type search space and the resource allocation indicating way in the DCI of the second type search space comprises:

receiving, by the terminal, the common signaling or the initial access information transmitted by the base station, determining frequency information of two or more than two resource allocations, wherein the frequency information comprises bandwidths and locations of all frequency resources for the resource allocations;

using one of the two or more than two resource allocations for the first type search space according to the common signaling or the initial access information, taking a bandwidth and a location of all frequency resources for the resource allocation as the bandwidth and the location of all the frequency resources available for the terminal frequency resource allocation in the DCI of the first type search space; and selecting a resource allocation for the second type search space from the two or more than two resource allocations according to a preset regulation, taking a bandwidth and a location of all the frequency resources for the resource allocation as the bandwidth and the location of all the frequency resources available for the terminal frequency resource allocation in the DCI of the second type search space.

[Claim 6] The method of claim 5, when the resource allocation indicating way for the first type search space and the resource allocation indicating way for the first type search space are determined, the terminal determines the allocation unit of the terminal frequency resource in the DCI of the first type search space and/or the second type search space according to the pre-configuration.

[Claim 7] The method of claim 5 or 6, wherein the frequency information comprises the allocation unit of the terminal frequency resource, and wherein, when the resource allocation indicating way for the first type search space and the resource allocation indicating way for the second type search space are determined, the terminal takes the allocation unit of the terminal frequency resource used in the resource allocation for the first type search space as the allocation unit of the terminal frequency resource in the DCI of the first type search space; and/or takes the allocation unit of the terminal frequency resource used in the resource allocation for the second type search space as the allocation unit of the terminal frequency resource in the DCI of the second type search space.

[Claim 8] The method of claim 1, wherein determining the resource allocation indicating way in the DCI of the first type search space and the resource allocation indicating way in the DCI of the first type search space

comprises:

receiving, by the terminal, the common signal or the initial access information transmitted by the base station, determining the frequency information of two or more resource allocations, wherein the frequency information comprises the bandwidths and the locations of all frequency resource for the resource allocations;

using, by the terminal, one of the two or more than two resource allocations for the first type search space, and taking the bandwidth and the location of all the frequency resource of the resource allocation as the bandwidth and the location of all the frequency resource available for the terminal frequency resource in the DCI of the first type search space; and

when the DCI of the terminal specific search space is the DCI of the fallback transmission mode, determining the resource allocation indicating way in the DCI of the terminal specific search space same as the resource allocation indicating way in the DCI of the first type search space; when the DCI of the terminal specific search space is the DCI of the non-fallback transmission mode, select a resource allocation used for the second type search space from the two or more than two resource allocations according to the preset regulation, taking the bandwidth and the location of all the frequency resources for the resource allocation as the bandwidth and the location of all the frequency resources available for the terminal frequency resource allocation in the DCI of the second type search space.

[Claim 9]

The method of claim 8, wherein, when the resource allocation indicating way in the DCI of the first type search space is determined, the terminal determines the allocation unit of the terminal frequency resource allocation in the DCI of the first type search space according to the pre-configuration;

and/or,

when the resource allocation indicating way in the DCI of the second type search space is determined and the DCI of the second type search space is the non-fallback transmission mode, the terminal determines the allocation unit of the terminal frequency resource allocation in the DCI of the second type search space according to the pre-configuration.

[Claim 10]

The method of claim 8 or 9, wherein the frequency information comprises the allocation unit of the terminal frequency resource, and wherein, when the resource allocation indicating way for the first type

search space and the resource allocation indicating way for the second type search space are determined, the terminal takes the allocation unit of the terminal frequency resource used in the resource allocation for the first type search type as the allocation unit of the terminal frequency resource in the DCI of the first type search space; and/or, when the DCI of the second type search space is the non-fallback transmission mode, the terminal takes the allocation unit of the terminal frequency resource used in the resource allocation for the second type search type as the allocation unit of the terminal frequency resource in the DCI of the second type search space.

[Claim 11]

The method of any of claims 1-10, before the terminal determines the resource allocation indicating way in the DCI of the first type search space, further comprising: determining at least one sub-bandwidth indicated in the DCI of the first type search space; wherein the determining the resource allocation indicating way in the DCI of the first type search space comprises: determining a resource allocation indicating way in each sub-bandwidth indicated by the DCI of the first type search space;

and/or,

before the terminal determines the resource allocation indicating way in the DCI of the second type search space, further comprising: determining at least one sub-bandwidth indicated in the DCI of the second type search space; wherein the determining the resource allocation indicating way in the DCI of the second type search space comprises: determining a resource allocation indicating way in each sub-bandwidth indicated by the DCI of the second type search space.

[Claim 12]

The method of any of claims 1-10, before the terminal determines the resource allocation indicating way in the DCI of the first type search space, further comprising: determining, by the terminal, whether a one-step way or a two-step way is used for indicating a frequency resource in the DCI of the first type search space according to received system information indication or received high layer signaling configuration; when determining that the one-step way is used, directly performing the way that the terminal determines the resource allocation indicating way in the DCI of the first type search space; when determining that the two-step way is used, before the terminal determines the resource allocation indicating way in the DCI of the first type search space, determining the at least one sub-bandwidth indicated in the DCI of the

first type search space, wherein the determining the resource allocation indicating way in the DCI of the first type search space comprises: determining a resource allocation indicating way in each sub-bandwidth indicated by the DCI of the first type search space;

and/or,

before the terminal determines the resource allocation indicating way in the DCI of the second type search space, further comprising: determining, by the terminal, whether a one-step way or a two-step way is used for indicating a frequency resource in the DCI of the second type search space according to received system information indication or high layer signaling configuration; when determining that the one-step way is used, directly performing the way that the terminal determines the resource allocation indicating way in the DCI of the second type search space; when determining that the two-step way is used, before the terminal determines the resource allocation indicating way in the DCI of the second type search space, determining the at least one sub-bandwidth indicated in the DCI of the second type search space, wherein the determining the resource allocation indicating way in the DCI of the second type search space comprises: determining the resource allocation indicating way in each sub-bandwidth indicated in the DCI of the second type search space.

[Claim 13]

The method of any of claims 1-10, when the DCI of the second type search space is DCI with a backoff mode, before the terminal determines the resource allocation indicating way in the DCI of the second type search space, further comprising: determining the at least one sub-bandwidth indicated in the DCI of the second type search space; wherein the determining the resource allocation indicating way in the DCI of the second type search space comprises: determining a resource allocation indicating way in each sub-bandwidth indicated in the DCI of the second type search space;

and/or,

when the DCI of the second type search space is DCI with a backoff mode, before the terminal determines the resource allocation indicating way in the DCI of the second type search space, further comprising: determining, by the terminal, whether a one-step way or a two-step way is used for indicating a frequency resource in the DCI of the second type search space according to received system information indication or received high layer signaling configuration; when determining that the

one-step way is used, directly performing the way that the terminal determines the resource allocation indicating way in the DCI of the second type search space; when determining that the two-step way is used, before the terminal determines the resource allocation indicating way in the DCI of the second type search space, determining the at least one sub-bandwidth indicated in the DCI of the second type search space, wherein the determining the resource allocation indicating way in the DCI of the second type search space comprises: determining the resource allocation indicating way in each sub-bandwidth indicated in the DCI of the second type search space.

[Claim 14]

The method of any of claims 11-13, wherein the number of physical resource blocks (PRBs) and locations of the PRBs included in the at least one sub-bandwidth in the DCI of the first type search space or in the DCI of the second type search space are preset, or are indicated by system information, or are determined according to system bandwidth.

[Claim 15]

An apparatus of a terminal for resource scheduling in a wireless communication system, the apparatus comprising: an indicating way determining module, a blind detecting module and an actual resource determining module,

wherein the indicating way determining module is configured to determine a resource allocation indicating way in downlink control information (DCI) of a first type search space and a resource allocation indicating way in the DCI of a second type search space, wherein the resource allocation indicating way comprises an allocation unit of a terminal frequency resource and a bandwidth and a location of all frequency resources available for terminal frequency resource allocation,

wherein the blind detecting module is configured to in the first type search space and the second type search space, perform blind detection for physical downlink control channel (PDCCH)/enhanced physical downlink control channel (EPDCCH) on the bandwidth and the location of all the frequency resources available for the terminal frequency resource allocation in the corresponding resource allocation indicating way according to the allocation unit of the terminal frequency resource in the corresponding resource allocation indicating way, and

wherein the actual resource determining module is configured to determine a bandwidth and a location of an uplink resource and/or a

downlink resource actually allocated for the terminal.

[Fig. 1]

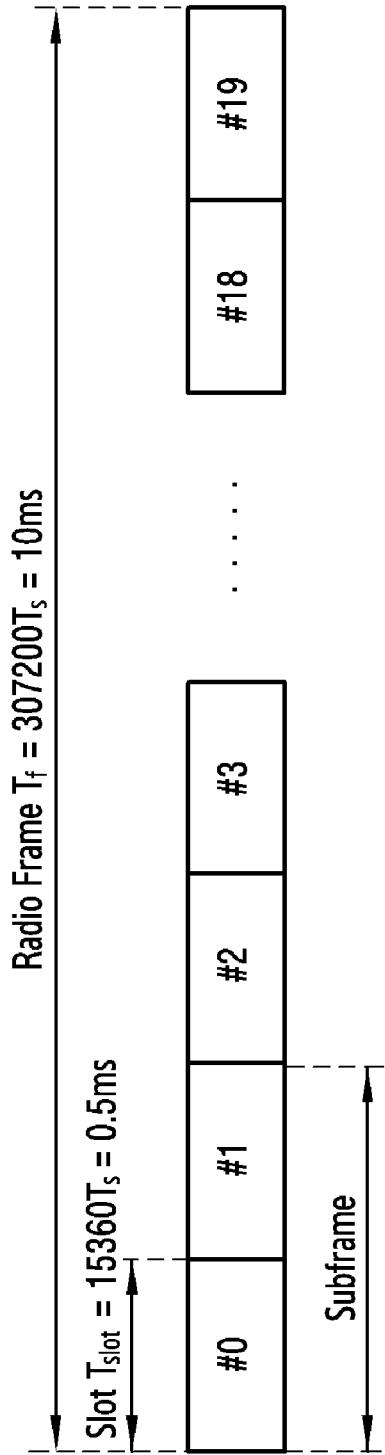

[Fig. 2]

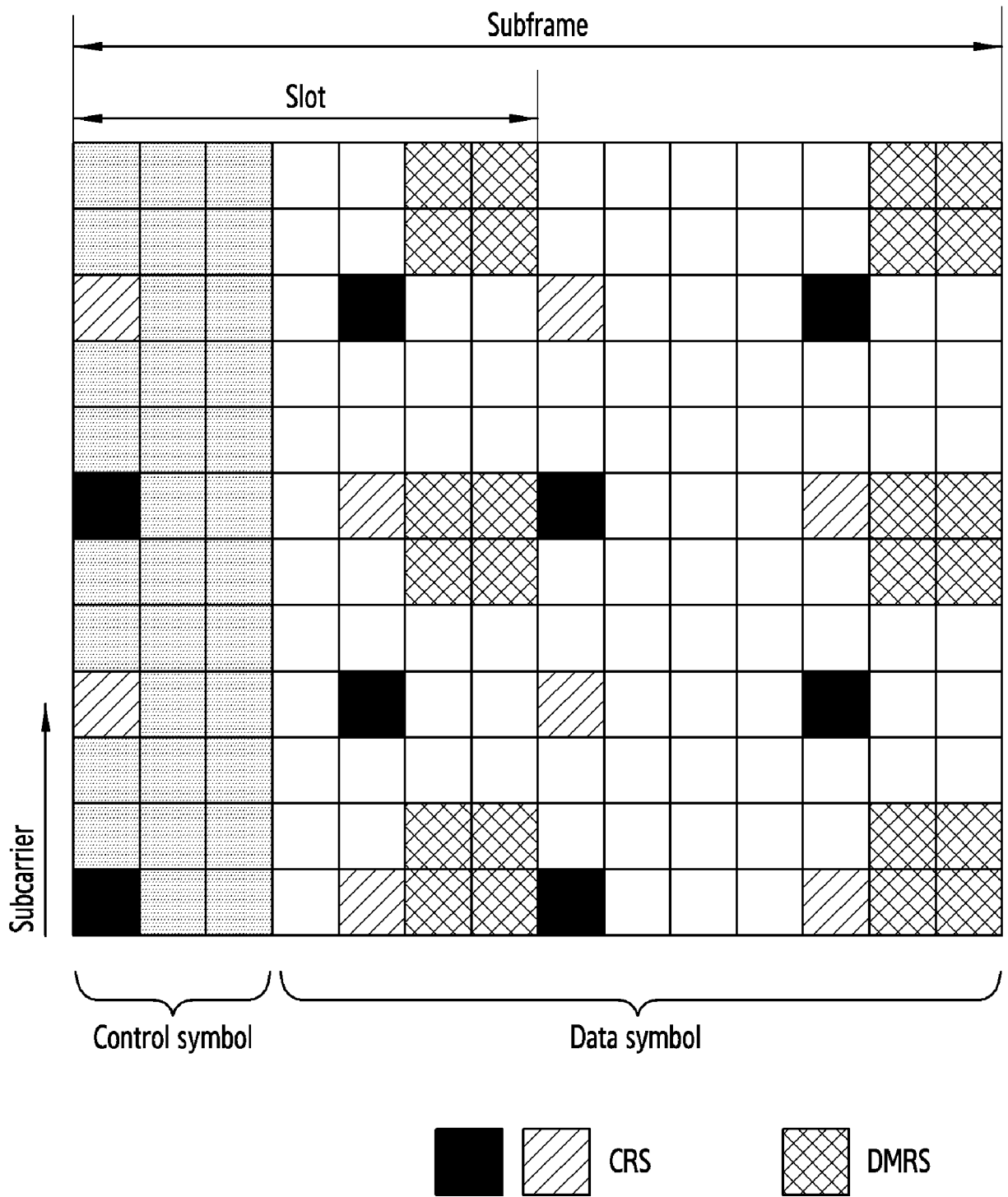

[Fig. 3]

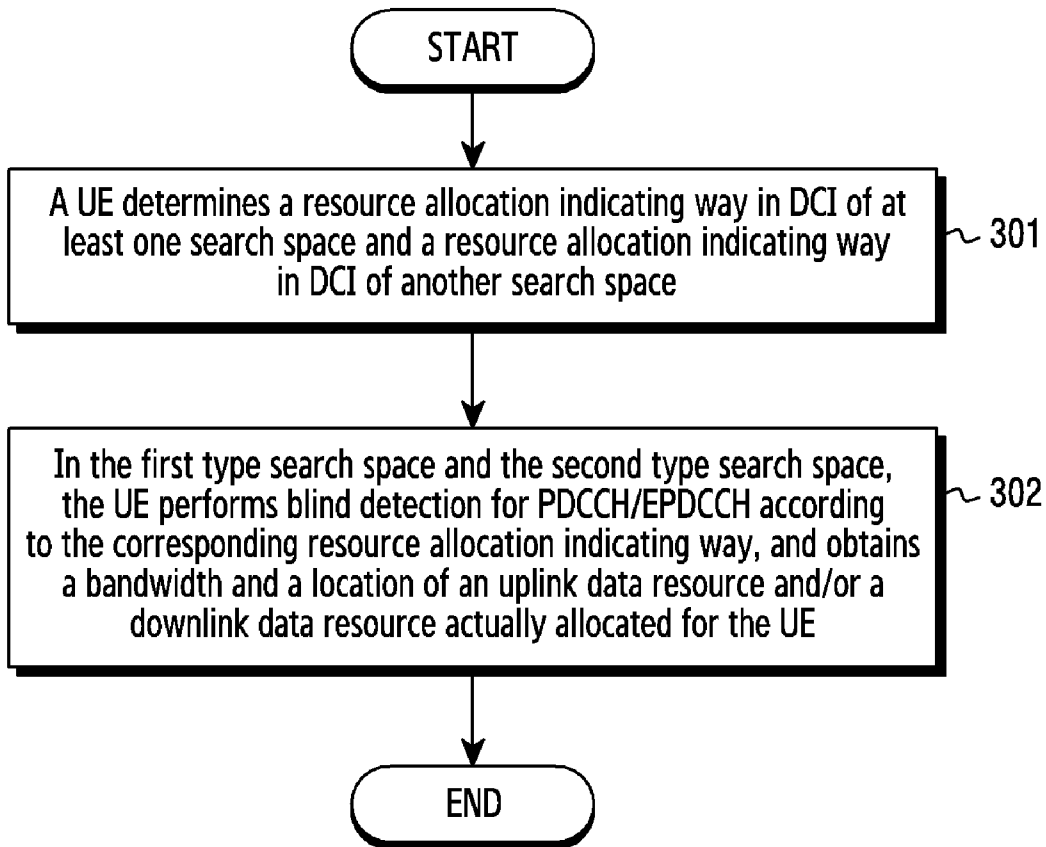

[Fig. 4]

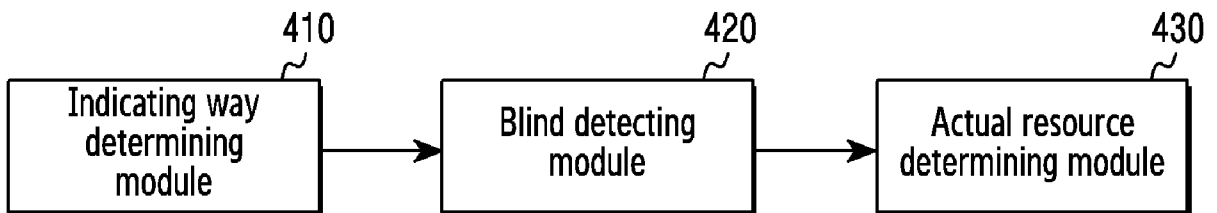

[Fig. 5]

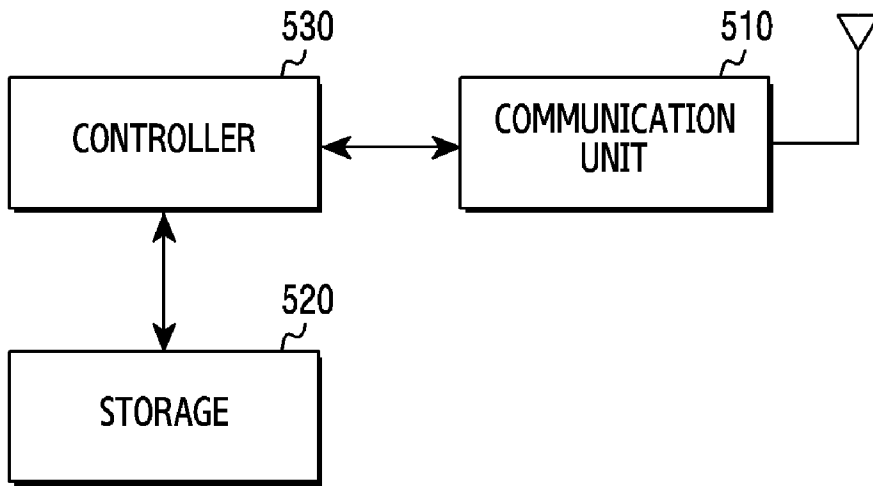

A. CLASSIFICATION OF SUBJECT MATTER**H04W 72/12(2009.01)i, H04W 72/04(2009.01)i**

According to International Patent Classification (IPC) or to both national classification and IPC

B. FIELDS SEARCHEDMinimum documentation searched (classification system followed by classification symbols)
H04W 72/12; H04W 8/00; H04W 72/04Documentation searched other than minimum documentation to the extent that such documents are included in the fields searched
Korean utility models and applications for utility models
Japanese utility models and applications for utility modelsElectronic data base consulted during the international search (name of data base and, where practicable, search terms used)
eKOMPASS(KIPO internal) & Keywords: UE specific search space, common search space, DCI, PDCCH, EPCCH, blind decoding, resource allocation**C. DOCUMENTS CONSIDERED TO BE RELEVANT**

Category*	Citation of document, with indication, where appropriate, of the relevant passages	Relevant to claim No.
A	US 2016-0037498 A1 (INTEL CORPORATION) 04 February 2016 See paragraphs [0037]-[0039]; and claims 1, 17.	1-15
A	US 2013-0250880 A1 (MEDIATEK, INC.) 26 September 2013 See paragraphs [0035]-[0039]; and figures 4-6.	1-15
A	US 2015-0049700 A1 (ALCATEL LUCENT) 19 February 2015 See paragraphs [0045]-[0054]; and claim 1.	1-15
A	WO 2013-008958 A1 (SHARP KABUSHIKI KAISHA et al.) 17 January 2013 See claims 1-4; and figures 7-9.	1-15
A	3GPP TS 36.213 v13.1.1, `3GPP; TSGRAN; Evolved Universal Terrestrial Radio Access (E-UTRA); Physical layer procedures (Release 13)', 31 March 2016 See section 7.1.	1-15

 Further documents are listed in the continuation of Box C. See patent family annex.

* Special categories of cited documents:

"A" document defining the general state of the art which is not considered to be of particular relevance

"E" earlier application or patent but published on or after the international filing date

"L" document which may throw doubts on priority claim(s) or which is cited to establish the publication date of another citation or other special reason (as specified)

"O" document referring to an oral disclosure, use, exhibition or other means

"P" document published prior to the international filing date but later than the priority date claimed

"T" later document published after the international filing date or priority date and not in conflict with the application but cited to understand the principle or theory underlying the invention

"X" document of particular relevance; the claimed invention cannot be considered novel or cannot be considered to involve an inventive step when the document is taken alone

"Y" document of particular relevance; the claimed invention cannot be considered to involve an inventive step when the document is combined with one or more other such documents, such combination being obvious to a person skilled in the art

"&" document member of the same patent family

Date of the actual completion of the international search

11 September 2017 (11.09.2017)

Date of mailing of the international search report

12 September 2017 (12.09.2017)

Name and mailing address of the ISA/KR

International Application Division
Korean Intellectual Property Office
189 Cheongsa-ro, Seo-gu, Daejeon, 35208, Republic of Korea

Facsimile No. +82-42-481-8578

Authorized officer

KANG, Hee Gok

Telephone No. +82-42-481-8264

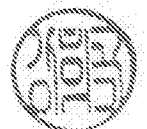

INTERNATIONAL SEARCH REPORT

Information on patent family members

International application No.

PCT/KR2017/005611

Patent document cited in search report	Publication date	Patent family member(s)	Publication date
US 2016-0037498 A1	04/02/2016	AU 2012-304276 A1	20/06/2013
		AU 2012-333172 A1	10/05/2013
		AU 2012-333172 B2	22/10/2015
		AU 2012-333237 A1	10/05/2013
		AU 2012-333237 B2	10/12/2015
		AU 2012-333239 A1	10/05/2013
		AU 2013-211872 A1	01/08/2013
		AU 2013-211872 B2	27/04/2017
		AU 2013-211927 A1	01/08/2013
		AU 2013-212088 A1	01/08/2013
		AU 2013-212088 B2	02/07/2015
		AU 2013-212110 A1	01/08/2013
		AU 2013-212110 B2	19/11/2015
		AU 2013-246041 A1	17/10/2013
		AU 2013-246041 B2	31/03/2016
		AU 2013-251441 A1	31/10/2013
		AU 2013-251441 B2	24/12/2015
		AU 2013-267841 A1	05/12/2013
		AU 2013-267841 B2	05/11/2015
		AU 2013-286893 A1	09/01/2014
		AU 2013-286893 B2	28/01/2016
		AU 2013-287185 A1	09/01/2014
		AU 2013-287185 B2	17/09/2015
		AU 2013-296189 A1	06/02/2014
		AU 2013-296189 B2	16/06/2016
		AU 2013-296976 A1	06/02/2014
		AU 2013-296976 B2	05/05/2016
		AU 2013-296977 A1	06/02/2014
		AU 2013-296977 B2	26/05/2016
		AU 2013-296991 A1	06/02/2014
		AU 2013-296991 B2	21/04/2016
		AU 2013-297032 A1	06/02/2014
		AU 2013-297032 B2	15/09/2016
		AU 2013-297042 A1	06/02/2014
		AU 2013-297042 B2	03/12/2015
		AU 2013-323321 A1	03/04/2014
		AU 2013-323321 B2	10/11/2016
		AU 2013-323624 A1	03/04/2014
		AU 2013-323624 B2	12/05/2016
		AU 2013-323978 A1	03/04/2014
AU 2013-323978 B2	21/04/2016		
AU 2015-203907 A1	09/07/2015		
CA 2850124 A1	10/05/2013		
CA 2853238 A1	10/05/2013		
CA 2853239 A1	10/05/2013		
CA 2857155 A1	06/06/2013		
CA 2861484 A1	01/08/2013		
CA 2862374 A1	01/08/2013		
CA 2863424 A1	01/08/2013		

INTERNATIONAL SEARCH REPORT

Information on patent family members

International application No.

PCT/KR2017/005611

Patent document cited in search report	Publication date	Patent family member(s)	Publication date
		CA 2863618 A1	01/08/2013
		CA 2868038 A1	17/10/2013
		CA 2868114 A1	31/10/2013
		CA 2871105 A1	05/12/2013
		CA 2874463 A1	09/01/2014
		CA 2874475 A1	09/01/2014
		CA 2874902 A1	09/01/2014
		CA 2878195 A1	06/02/2014
		CA 2878215 A1	06/02/2014
		CA 2878327 A1	06/02/2014
		CA 2878329 A1	06/02/2014
		CA 2878379 A1	06/02/2014
		CA 2882353 A1	03/04/2014
		CA 2926378 A1	06/02/2014
		CA 2931649 A1	09/07/2015
		CA 2931664 A1	09/07/2015
		CA 2932387 A1	10/05/2013
		CA 2957198 A1	17/10/2013
		CN 103368940 A	23/10/2013
		CN 103368940 B	12/04/2017
		CN 103369467 A	23/10/2013
		CN 103369467 B	22/06/2016
		CN 103379599 A	30/10/2013
		CN 103379599 B	28/12/2016
		CN 103428659 A	04/12/2013
		CN 103517327 A	15/01/2014
		CN 103532680 A	22/01/2014
		CN 103546477 A	29/01/2014
		CN 103581861 A	12/02/2014
		CN 103581880 A	12/02/2014
		CN 103581965 A	12/02/2014
		CN 103582003 A	12/02/2014
		CN 103582006 A	12/02/2014
		CN 103582006 B	12/04/2017
		CN 103582057 A	12/02/2014
		CN 103582066 A	12/02/2014
		CN 103596065 A	19/02/2014
		CN 103596065 B	01/03/2017
		CN 103763694 A	30/04/2014
		CN 103797771 B	01/03/2017
		CN 104054386 A	17/09/2014
		CN 104067536 A	24/09/2014
		CN 104067537 A	24/09/2014
		CN 104067549 A	24/09/2014
		CN 104067593 A	24/09/2014
		CN 104067593 B	22/02/2017
		CN 104067643 A	24/09/2014
		CN 104067667 A	24/09/2014
		CN 104067673 A	24/09/2014
		CN 104067674 A	24/09/2014

INTERNATIONAL SEARCH REPORT

Information on patent family members

International application No.

PCT/KR2017/005611

Patent document cited in search report	Publication date	Patent family member(s)	Publication date
		CN 104067684 A	24/09/2014
		CN 104067688 A	24/09/2014
		CN 104081681 A	01/10/2014
		CN 104081684 A	01/10/2014
		CN 104081696 A	01/10/2014
		CN 104081798 A	01/10/2014
		CN 104093398 A	08/10/2014
		CN 104093398 B	15/03/2017
		CN 104137611 A	05/11/2014
		CN 104145489 A	12/11/2014
		CN 104145524 A	12/11/2014
		CN 104170271 A	26/11/2014
		CN 104170521 A	26/11/2014
		CN 104205734 A	10/12/2014
		CN 104205977 A	10/12/2014
		CN 104221307 A	17/12/2014
		CN 104221410 A	17/12/2014
		CN 104272615 A	07/01/2015
		CN 104272689 A	07/01/2015
		CN 104272791 A	07/01/2015
		CN 104303446 A	21/01/2015
		CN 104365037 A	18/02/2015
		CN 104412660 A	11/03/2015
		CN 104769865 A	08/07/2015
US 2013-0250880 A1	26/09/2013	CN 104081851 A	01/10/2014
		EP 2689624 A1	29/01/2014
		JP 2015-518305 A	25/06/2015
		US 2016-0353421 A1	01/12/2016
		US 9445409 B2	13/09/2016
		US 9681436 B2	13/06/2017
		WO 2013-139285 A1	26/09/2013
US 2015-0049700 A1	19/02/2015	CN 103327521 A	25/09/2013
		CN 103327521 B	14/12/2016
		EP 2829033 A1	28/01/2015
		JP 2015-515794 A	28/05/2015
		JP 6022033 B2	09/11/2016
		KR 10-1615062 B1	22/04/2016
		KR 10-2014-0145159 A	22/12/2014
		RU 2014142044 A	10/05/2016
		TW 201349909 A	01/12/2013
		TW I496494 B	11/08/2015
		WO 2013-140241 A1	26/09/2013
WO 2013-008958 A1	17/01/2013	CN 102883368 A	16/01/2013