

(No Model.)

2 Sheets—Sheet 1.

T. DEPP & E. H. SELBY.

GATE.

No. 334,516.

Patented Jan. 19, 1886.

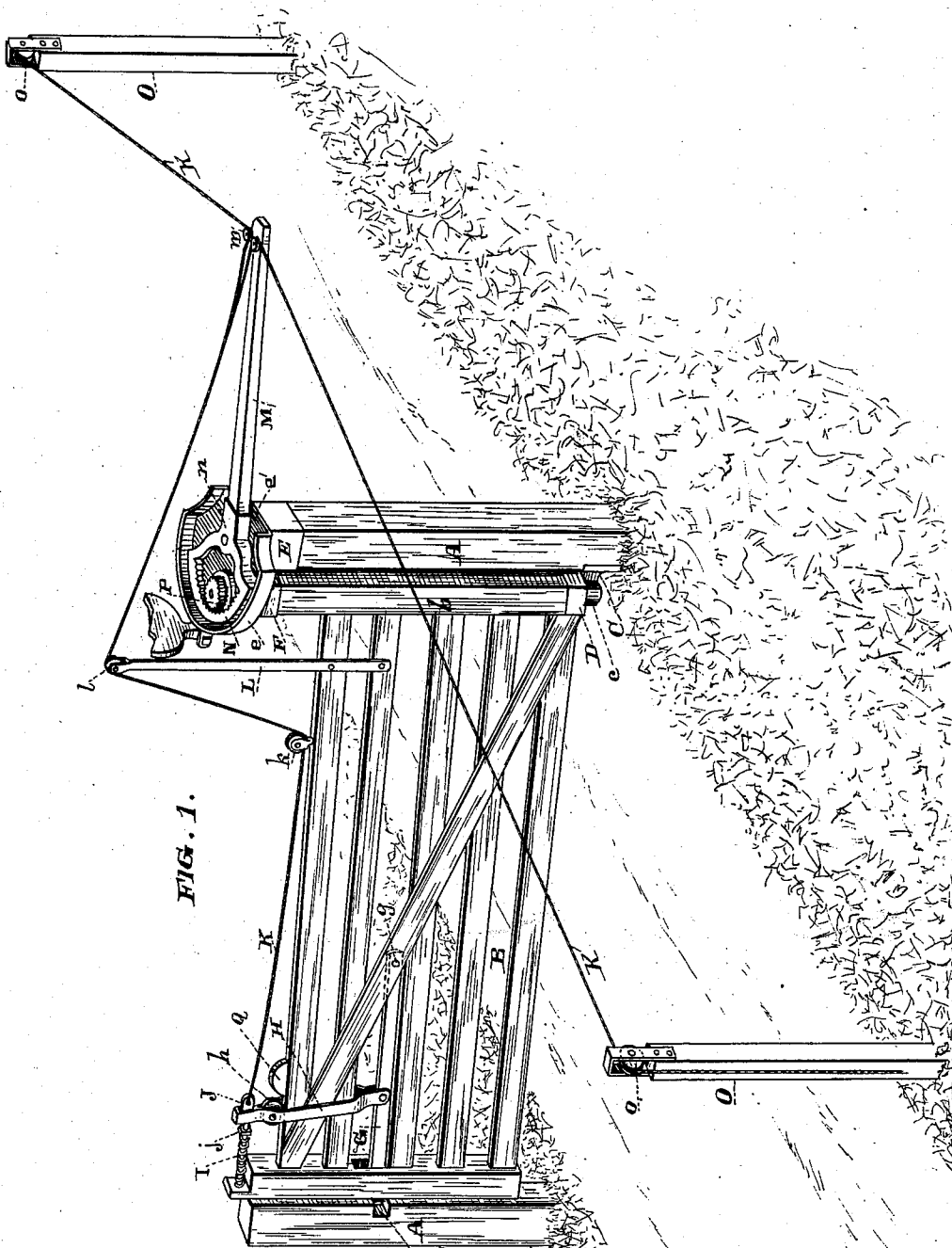

FIG. 1.

Witnesses,
H. C. Lee.

Inventors,
T. Depp
E. H. Selby.
Depp & Selby
 Attorneys

(No Model.)

T. DEPP & E. H. SELBY.

2 Sheets—Sheet 2.

GATE.

No. 334,516.

Patented Jan. 19, 1886.

FIG. 2.

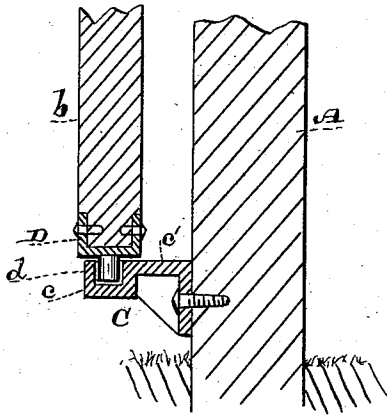
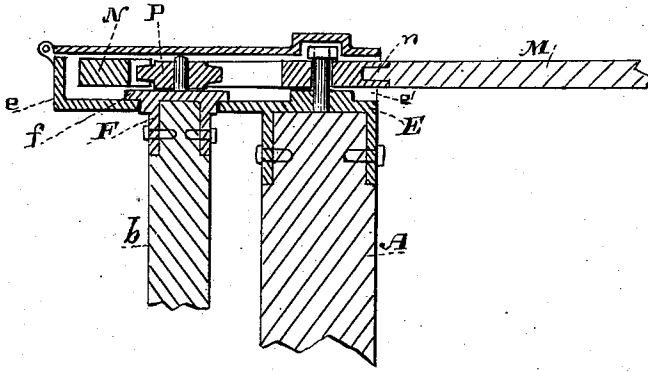
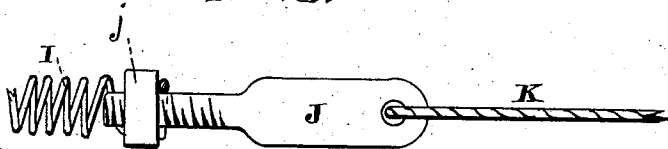

FIG. 3.



Witnesses,
J. H. House.
H. C. Lee.

Inventors,
Thos. Depp.
E. H. Selby
By Depp & Selby
Attorneys

UNITED STATES PATENT OFFICE.

THOMAS DEPP, OF MOORE'S STATION, AND EDWARD H. SELBY, OF MARYSVILLE, CALIFORNIA.

GATE.

SPECIFICATION forming part of Letters Patent No. 334,516, dated January 19, 1906.

Application filed August 31, 1885. Serial No. 175,859. (No model.)

To all whom it may concern:

Be it known that we, THOMAS DEPP, of Moore's Station, Butte county, State of California, and EDWARD H. SELBY, of Marysville, Yuba county, State of California, have invented an Improvement in Gates; and we hereby declare the following to be a full, clear, and exact description of the same.

Our invention relates to that class of gates which are adapted to be opened and closed by the passing traveler without the necessity of alighting from his vehicle or conveyance, and especially to those gates which, by means of suitably-directed ropes by the roadside, have their latches raised and are swung to an open or closed position.

Our invention consists in the devices which we shall hereinafter fully describe by reference to the accompanying drawings, in which—

Figure 1 is a perspective view of our gate. Fig. 2 is a vertical section through the pivot-post *b* of the gate and the adjoining gate-post. Fig. 3 is a view of the bolt J.

The object of our invention is to provide a simple and effective gate of this class.

A are the gate-posts, and B is the gate, of any suitable construction.

b is the pivot-post of the gate, which is hinged as follows to one of the gate-posts: On the bottom of the gate-post is a casting, C, consisting of a socketed piece, *c*, and a flange, *c'*, by which it is bolted to the gate-post. On the bottom of the pivot-post *b* is secured a casting, D, which consists of a socketed piece fitting on the post, and having a stem, *d*, which is journaled in the socket *c* of casting C. On top of the gate-post A is bolted a casting, E, having a curved annular extension, *e*, with a hinged cap and an open end, *e'*. On top of the pivot-post is secured a casting, F, which extends up through a hole in the base of the extension *e*, and has a flange, *f*, bearing on the upper surface of said extension. These several castings form the hinges on which the gate pivots. G is the latch of the gate, pivoted at *g*, and adapted to engage with the ordinary bevel-sided catch *a* of one of the gate-posts. Pivoted to this latch, and extending upward on both sides of the gate, is a link, H, which carries in its top a roller, *h*. In the

link above the roller is a bolt, J, one end of which has a nut, *j*, which secures the end of a spiral spring, I, the other end of which is bolted to the upright end of the gate. To the eye of the bolt J is secured the rope K, which passes along the top of the gate under the guide-pulley *k* thereon. Bolted to the gate is a vertical standard, L, carrying in its top a pulley, *l*, over which the rope K is guided.

M is a lever, the inner end of which is fitted in a socket, *n*, of an internal segmental gear, N, which is housed within the extension *e* of the casting E. The outer end of the lever M is provided with pulleys *m*, around which the rope K passes, said rope being here divided and extending in opposite directions along the roadside to the guide-pulleys *o* on the side posts, O. On top of the casting F, which forms a part of one of the hinges of the gate, is a pinion, P, with which the segmental gear N meshes. On top of the gate is a curved lug or cam, Q.

The operation of our gate is as follows: The traveler approaching takes hold of and pulls the rope K. The first effect is to draw the link H back, so that its roller *h* travels on the cam Q of the gate, whereby the link is raised, thereby raising the latch G from its engagement with the catch *a*. The continued pulling of the rope causes the lever M to be drawn toward the traveler, whereby the segmental gear N, meshing with the pinion P on top of the pivot-post of the gate, causes the gate to swing open in a direction away from the traveler until its latch engages a catch on the side post, *o*. When the tension on the rope is relieved, the spring I returns the link to its former position, allowing the latch to remain in its engagement and ready to be released, which release takes place when the traveler, having passed through the gate, pulls the opposite rope, whereby the gate is closed again.

Having thus described our invention, what we claim as new, and desire to secure by Letters Patent, is—

1. The gate B, having the pivoted latch G, and a curved cam, Q, on its top, in combination with the means for releasing said latch, consisting of the link H, pivoted to the latch, and having a roller, *h*, in its top adapted to

travel on the cam Q, and the rope K, connected with said link, substantially as herein described.

2. The gate B, having the cam Q on its top, and a pivoted latch, G, in combination with the link H on the gate pivoted to the latch, the roller *h* in said link adapted to travel on the cam to raise the latch, the eyebolt J in the link, the spring I, attached to one end of the bolt, and the rope K, attached to its other end, substantially as herein described.

3. The combination of the post A, casting E, secured to the top thereof and having the circular open-ended extension or housing *e*, lever M, pivoted on said casting and carrying the segmental gear N, which fits within the extension, the rope K, secured to the lever, the gate B, having pivot-post *b*, and the pinion P, mounted on top of said post, substantially as herein described.

4. The gate-post A and the gate B, having the pivot-post *b*, suitably hinged at its base to the gate-post, in combination with the casting E on top of the gate-post, having the circular open-ended extension or housing *e*, the casting F on top of the pivot-post having top flange, *f*, bearing on the extension *e* and forming the top hinge, the lever M, having segmental gear N, fitted within the extension or housing *e*, the pinion P on top of the casting F, meshing with the segmental gear, and a rope attached to the end of the lever M, substantially as herein described.

5. The gate-post A and the gate B, having pivot-post *b*, in combination with the hinges, consisting of the casting C on the gate post below, and the casting D on the pivot-post, the casting E on the gate-post above having circular open-ended extension *e*, the casting F on top of the pivot-post having top flange, *f*, and the means by which the gate is operated, consisting of the lever M, the segmental gear

N, to which the lever is attached, said gear being housed in the extension *e*, the pinion P on top of the casting F, and a rope, K, attached to the lever M, substantially as herein described.

6. The gate-posts A and the gate B, having pivot post *b*, hinged to one of the posts, a pivoted latch, G, adapted to engage the catch of the other post, and a curved cam, Q, on its top, in combination with the means by which the latch is released and the gate operated, consisting of the link H, pivoted to the latch, and having a roller, *h*, in its top adapted to travel on the cam Q of the gate, and the spring I, for returning said link, the lever M, having segmental gear N, the pinion P on top of the pivot-post, with which the segmental gear engages, and the rope K, attached to the link and passing over suitable guide-pulleys and around a pulley on the end of the lever M, substantially as herein described.

7. The gate-posts A and the gate B, having pivot post *b*, hinged to one of the gate-posts, a latch, G, adapted to engage with the catch of the other gate-post, a cam, Q, on its top, and a standard, L, in combination with the link H, having roller *h*, the spring I, returning said link, the lever M, having segmental gear N, guided on top of the gate-post, the pinion P on the pivot-post of the gate, and the rope K, attached to the link and passing around suitable guide-pulleys in the standard and the end of the lever, substantially as herein described.

In witness whereof we have hereunto set our hands.

THOMAS DEPP.
EDWARD H. SELBY.

Witnesses:

GEO. WAPPEL,
J. H. KRAUSE.