

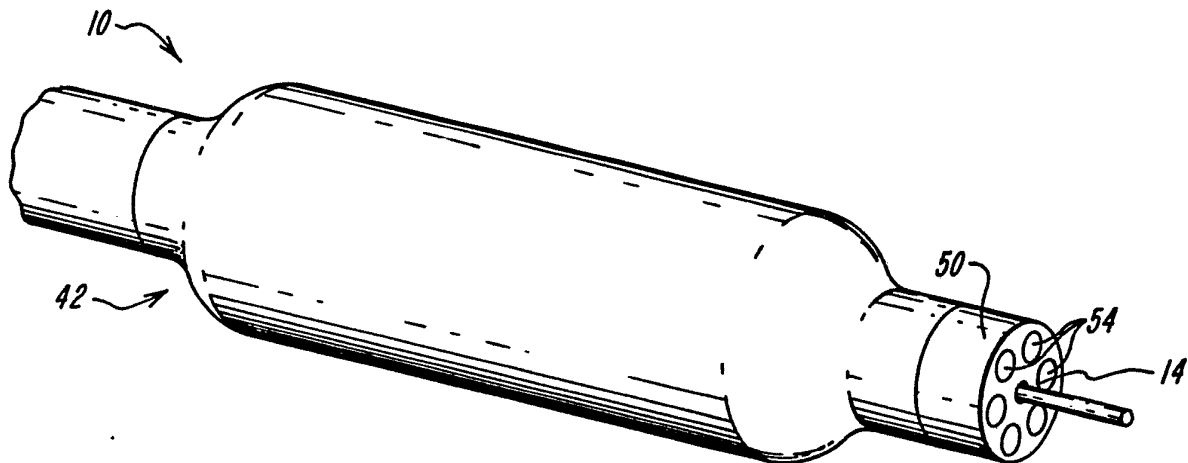

INTERNATIONAL APPLICATION PUBLISHED UNDER THE PATENT COOPERATION TREATY (PCT)

<p>(51) International Patent Classification ⁵ : A61N 5/06, A61B 17/22</p>	<p>A2</p>	<p>(11) International Publication Number: WO 92/06741 (43) International Publication Date: 30 April 1992 (30.04.92)</p>
<p>(21) International Application Number: PCT/US91/06313 (22) International Filing Date: 4 September 1991 (04.09.91) (30) Priority data: 595,033 10 October 1990 (10.10.90) US (71) Applicant: BOSTON ADVANCED TECHNOLOGIES, INC. [US/US]; 656 Beacon Street, Boston, MA 02215 (US). (72) Inventor: CLARKE, Richard, H. ; 55 Collier Road, P.O. Box 354, Scituate, MA 02066 (US). (74) Agents: ENGELLENNER, Thomas, J. et al.; Lahive & Cockfield, 60 State Street, Boston, MA 02109 (US).</p>		<p>(81) Designated States: AT (European patent), AU, BE (European patent), CA, CH (European patent), DE (European patent), DK (European patent), ES (European patent), FR (European patent), GB (European patent), GR (European patent), IT (European patent), JP, KR, LU (European patent), NL (European patent), SE (European patent). Published <i>Without international search report and to be republished upon receipt of that report.</i></p>

(54) Title: INHIBITION OF RESTENOSIS BY ULTRAVIOLET RADIATION



(57) Abstract

Restenosis following angioplasty can be inhibited by reducing the proliferation of smooth muscle cells in the blood vessel walls at an angioplasty site, and such reduction in cell proliferation can be accomplished by an apparatus which irradiates the angioplasty site with radiation in the ultraviolet (UV) wavelength range. The ultraviolet radiation is preferably delivered via an optical fiber or other waveguide incorporated, for example, into a percutaneous catheter. In operation, the ultraviolet radiation kills smooth muscle cells at the site, thereby reducing the risk of restenosis, while minimizing damage to surrounding tissue.

FOR THE PURPOSES OF INFORMATION ONLY

Codes used to identify States party to the PCT on the front pages of pamphlets publishing international applications under the PCT.

AT	Austria	ES	Spain	MG	Madagascar
AU	Australia	FI	Finland	ML	Mali
BB	Barbados	FR	France	MN	Mongolia
BE	Belgium	GA	Gabon	MR	Mauritania
BF	Burkina Faso	GB	United Kingdom	MW	Malawi
BG	Bulgaria	GN	Guinea	NL	Netherlands
BJ	Benin	GR	Greece	NO	Norway
BR	Brazil	HU	Hungary	PL	Poland
CA	Canada	IT	Italy	RO	Romania
CF	Central African Republic	JP	Japan	SD	Sudan
CG	Congo	KP	Democratic People's Republic of Korea	SE	Sweden
CH	Switzerland	KR	Republic of Korea	SN	Senegal
CI	Côte d'Ivoire	LI	Liechtenstein	SU ⁺	Soviet Union
CM	Cameroon	LK	Sri Lanka	TD	Chad
CS	Czechoslovakia	LU	Luxembourg	TG	Togo
DE ⁺	Germany	MC	Monaco	US	United States of America
DK	Denmark				

⁺ Any designation of "SU" has effect in the Russian Federation. It is not yet known whether any such designation has effect in other States of the former Soviet Union.

INHIBITION OF RESTENOSIS BY ULTRAVIOLET RADIATION5 Background of the Invention

The technical field of this invention is surgical instruments and procedures and, in particular, systems and methods for inhibiting
10 restenosis associated with angioplasty.

Atherosclerosis is a disease which causes thickening and hardening of the arteries, characterized by lesions of raised fibrous plaque
15 formed within the arterial lumen. Atherosclerotic plaque is commonly treated by means of angioplasty through the use of a balloon catheter. Balloon angioplasty involves passing a small, balloon-tipped catheter percutaneously into an artery and up to the
20 region of obstruction. The balloon is then inflated to dilate the area of obstruction. Other devices, such as atherosclerectomy instruments which remove obstructions by dealing or shaving plaque from the artery wall, are also utilized in the treatment of
25 atherosclerosis. More recently, laser systems have been proposed for performing angioplasty. In laser angioplasty, a catheter carrying a fiber optic waveguide is passed through a blood vessel, positioned near an obstruction, and then activated to
30 decompose the plaque with laser radiation.

2.

At present, over 200,000 angioplasty procedures are performed each year in the United States. Unfortunately, restenosis, or closure of the blood vessel following angioplasty, is a common occurrence following all types of such surgery. Approximately 30% of segments dilated by means of balloon catheter will develop significant restenosis, with peak incidence occurring between 2 and 3 months after angioplasty. Similar restenosis rates accompany laser angioplasty. When restenosis occurs, further coronary difficulties can result including strokes, arrhythmia, infarcts and even death.

Evidence suggests that intimal hyperplasia or proliferation of smooth muscle cells is a major factor in restenosis. Proliferation of smooth muscle cells is very common in patients after angioplasty, whether or not restenosis occurs. Medial smooth muscle cells, a main component of the arterial wall, proliferate in response to any injury to the arterial wall. Smooth muscle cells enter their growth cycle between 2 and 3 days after injury, and the majority of smooth muscle cells will cease to proliferate within 7 days. The total number of smooth muscle cells in the intima reaches a peak about two weeks after injury and remains constant for up to one year, suggesting that a reduction of the number of smooth muscle cells injured during angioplasty will reduce the likelihood of subsequent restenosis. See, generally, Liu et al., "Restenosis After Coronary Angioplasty, Potential Biologic Determinants and Role of Intimal Hyperplasia," Vol. 79, Circulation, pp. 1374-1387 (1989).

At present, efforts to prevent restenosis typically consists of drug therapy or modification of angioplasty techniques. Drug therapy is primarily directed toward the control of restenosis through the
5 use of antiplatelet agents, antiproliferative agents, or antimigratory agents. The goal of drug therapy is to reduce smooth muscle cell proliferation by attacking the smooth muscle cells directly, or by affecting processes that promote smooth muscle cell
10 proliferation. Unfortunately, most of the drugs under investigation are unproven, with unknown efficiency and side effects.

An alternative approach to reduce restenosis
15 is to modify the techniques used in performing angioplasty. Until recently, angioplasty was performed by passing a small, balloon-tipped catheter percutaneously to an obstruction site and then inflating the balloon to dilate the area of
20 obstruction. In balloon angioplasty, the outward compression of the balloon stresses the vessel walls, often resulting in cracking or tearing of the wall and injury to the smooth muscle cells. This injury, in turn, increases the risk of restenosis. One
25 method to reduce restenosis resulting from balloon angioplasty is to heat the balloon during dilation to "seal" the injured vessel wall. See, for example, U.S. Pat. No. 4,754,752 issued to Ginsberg et al. on July 5, 1988.

Modified forms of laser angioplasty have also been proposed to remove atherosclerotic obstructions. Up until recently, researchers in laser angioplasty primarily have relied upon
5 continuous wave (CW) lasers. Such lasers, while sufficient to ablate an obstruction, can also substantially cause thermal injury to vessel walls adjacent to the obstruction. Recently, high energy excimer lasers and other pulsed laser sources, which
10 possess high peak intensity levels and very rapid pulse rates, have been found to destroy the target obstruction while minimizing the thermal injury to surrounding tissue.

15 Nonetheless, even with these less traumatic procedures, restenosis continues to be a significant factor compromising the effectiveness of angioplasty.

 There exists a need for better methods and
20 devices for preventing restenosis after angioplasty. A system which could perform angioplasty, while reducing the likelihood of smooth muscle cell proliferation in the vicinity of the angioplasty site, would satisfy a significant need in the art.
25

Summary of the Invention

Restenosis following angioplasty can be inhibited by reducing the proliferation of smooth muscle cells in the blood vessel walls at an angioplasty site, and such reduction in cell proliferation can be accomplished by irradiating the angioplasty site with the appropriate radiation in the ultraviolet (UV) wavelength range. The ultraviolet radiation is preferably delivered via an optical fiber or other waveguide incorporated, for example, into a percutaneous catheter. In operation, the ultraviolet radiation kills smooth muscle cells at the site, thereby reducing the risk of restenosis, while minimizing damage to surrounding tissue.

Various UV radiation sources can be use in accordance with the present invention to deliver restenosis-preventive therapy, including both laser and non-coherent radiation sources. Either pulsed or continuous wave ("CW") lasers can be used, and the lasant medium can be gaseous, liquid or solid state. One preferred laser source is a pulsed excimer laser, such as a KrF laser. Alternatively, rare earth-doped solid state lasers, ruby lasers and Nd:YAG lasers can be operated in conjunction with frequency modification means to produce an output beam at the appropriate UV wavelength. In another alternative, a UV flash lamp can be employed.

The UV radiation source preferably produces an output beam having a wavelength less than about 280 nanometers. The therapeutic UV radiation useful in the present invention will typically range from 5 about 280 nanometers down to about 240 nanometers (due to the limited transmission efficiency of glass fibers at lower wavelengths). In one preferred embodiment, a laser system is disclosed which operates at about 266 nanometers to maximize the 10 cytotoxic effect of the radiation. Other useful UV radiation sources include, for example, Argon ion lasers emitting UV light at about 257 nanometers and KrF excimer lasers emitting light at about 248 nanometers.

15

The invention can be practiced with a low energy radiation source. The term "low energy" is used herein to describe both laser and non-coherent radiation systems having an energy output of less 20 than about 5 millijoules.

Usage of a high energy pulsed UV radiation source may be preferred for some applications. The term "high energy" is used herein to describe lasers 25 which have an energy output of more than 5 millijoules or which generate peak powers on the order of 100 kilowatts per square centimeter or greater.

In one embodiment of the invention, at least one optical fiber for transmission of UV radiation is incorporated into a conventional balloon angioplasty device and operated to deliver therapeutical UV radiation to the angioplasty site either at the same time the balloon is inflated, or shortly before or after inflation. In one preferred method, the balloon is first inflated to displace the vessel-obstructing plaque or lesion, and then the balloon is retracted to permit irradiation of the site by one or optical waveguides incorporated into the catheter. In one illustrated embodiment, the balloon catheter has a diffusive tip through which the therapeutic UV laser radiation of the invention is delivered.

In another embodiment of the invention, at least one optical waveguide for transmission of UV radiation can be incorporated into an laser angioplasty device as an adjunct to the delivery of ablative laser radiation. Thus, a single catheter preferably can carry two bundles of optical fibers, one bundle serving to deliver ablative radiation (e.g., from a high energy, pulsed, excimer laser) and the other bundle carrying the UV radiation to kill a portion of the cells in the vicinity of the ablation site which would otherwise proliferate.

In this embodiment, the ablative and therapeutic radiation can be provided by two or more lasers operating in tandem, one laser source being used to deliver ablative laser radiation, and another
5 laser source then employed to inhibit restenosis. In one preferred embodiment, separate optical waveguides can be used to deliver the ablative and therapeutic laser radiation, and two controllers are provided, one for each laser source, to allow them to operate
10 independently. Alternatively, the ablative and therapeutic radiation can multiplexed and delivered via the same waveguide. The ablative laser radiation source can be any form of laser deemed appropriate for the particular application involved. In another
15 alternative, a tunable laser delivering radiation at two or more wavelengths can be used and may be preferred for particular applications.

In yet another embodiment of the invention,
20 a single wavelength of UV laser radiation can be generated, and such radiation can also be used to ablate the vessel-obstructing plaque or other lesion as well as reduce restenosis. Thus, in this embodiment, UV radiation is transmitted through an
25 optical waveguide to both perform angioplasty and kill smooth muscle cells at the angioplasty site.

In another aspect of the invention, novel UV radiation sources are disclosed herein which overcome the problems of low transmissivity and low damage thresholds in fused silica or glass fibers by doping the fiber with a lasant such as Neodymium. The optical fiber is then pumped by energy from an optical pump source and acts as an amplifier to produce a full strength laser output beam at its distal end. High intensity pulsed radiation can be achieved by introducing a low power laser pulse into the proximal end of the fiber. Short wavelength visible and/or ultraviolet radiation can be obtained by disposing one or more frequency-modifying elements at the distal end of the instrument.

15 In one illustrated embodiment, a laser having an output beam wavelength of about 1064 nanometers, such as a common Nd:YAG laser, can be used in conjunction with two doubling crystals to yield a radiation output of about 266 nanometers and an energy output of about 5-10 millijoules. A grouping of six to eight fibers delivering such radiation can be used to provide the laser power necessary for both ablation of plaque and treatment of the site to reduce the likelihood of restenosis.

25

Novel catheter systems are also disclosed herein. Such catheter systems are useful in the performance of either balloon angioplasty or laser angioplasty and are preferably equipped with at least
5 one optical waveguide for delivery of the UV radiation therapy, which can be, for example, an optical fiber having about a 200 micron diameter core. The catheter tip can also contain focusing optics or diffusive elements for use in directing the
10 radiation emitted from the catheter within an artery.

The invention will next be described in connection with certain illustrated embodiments. However, it should be clear that various changes and
15 modifications can be made by those skilled in the art without departing from the spirit or scope of the invention.

Brief Description of the Drawings

FIG. 1 is a schematic perspective view of a combined balloon and laser therapy catheter for performing angioplasty and reducing the likelihood of restenosis;

FIG. 2 is a view of the distal end of the catheter of FIG. 1;

FIGS. 3A-3C are schematic cross-sectional illustrations of a system incorporating the catheter of FIG. 1 in use to dilate a blood vessel and prevent restenosis;

FIG. 4 is a schematic perspective view of an alternative catheter for performing angioplasty and reducing the likelihood of restenosis;

FIG. 5 is a view of the distal end of the catheter of FIG. 4;

FIGS. 6A-6C are schematic cross-sectional illustrations of a system incorporating the catheter of FIG. 4 in use to dilate a blood vessel and prevent restenosis; and

FIG. 7 is a schematic illustration of a laser device useful in the present invention.

30

Detailed Description

In FIG. 1, a combined balloon and laser therapy catheter 10 is shown, including inflatable 5 balloon section 42 and a guide wire 14. Also disposed within the catheter are a plurality of optical fibers 54 for delivery of ultraviolet radiation. The catheter can also include a radio-opaque tip 50. In FIG. 2, the distal end 12 of 10 the catheter of FIG. 1 is shown in more detail, including an exemplary disposition of six optical fibers 54 about a central guide wire 14.

The use of the catheter system 10 is 15 schematically illustrated in FIGS. 3A-3C. In use, the guide wire 14 is first introduced into the obstructed blood vessel and used to guide the catheter 10 into position adjacent to the plaque or lesion (e.g., under radiographic control). As shown 20 in FIG. 3A, the balloon section 42 is then inflated to form a balloon 44 which applies pressure against the obstruction 20, thereby dilating the obstructed region of the blood vessel 16. Inflation and deflation of the balloon 44 are controlled by a 25 balloon controller 46.

In FIG. 3B, the balloon section 42 is deflated and retracted so that the distal tip of the catheter can be positioned to deliver UV radiation 30 therapy to the angioplasty site 32. A therapeutical laser 28 can then be activated to deliver UV radiation 30 which will kill a major portion of the smooth muscle cells 40 within the media 24 of the blood vessel wall without damaging either the inner 35 endothelium layer 22 or the outer adventitia 26 of the blood vessel.

As shown in FIG. 3C, the end result of the operation is a substantially lessened obstruction with few, if any, smooth muscle cells remaining in the angioplasty site to proliferate and cause
5 restenosis.

In FIGS. 4 and 5, an alternative catheter configuration 10A for performing both angioplasty and reducing the likelihood of stenosis is shown,
10 including a guide wire 14 and two laser radiation delivery systems 76 and 78. The first laser delivery system 76 provides therapeutic UV radiation to inhibit restenosis. The second laser delivery system
15 78 operates to provide ablative laser radiation to remove obstructions in a blood vessel by photodecomposition. Like the system of FIG. 1, the catheter of FIG. 4 can also include a radio-opaque tip 50 to aid in positioning the catheter within a blood vessel under radiographic control.

20
As shown in more detail in FIG. 5, the distal end of 12A of the catheter can include both the therapeutic UV radiation delivery system 76 and the ablative laser radiation delivery system 78.
25 Multiple optical fibers 54 for UV radiation therapy are encased in a sleeve 66 which is positioned on one side of the guide wire to provide the UV therapy system. A second sleeve 67, encasing another set of optical fibers 68 for laser ablation, is positioned
30 on the other side of the guide wire 14.

-14-

The catheter can further include a flushing port 72 for the introduction of saline at the site and/or a suction port 74 for clearing the site of fluids during laser operations. The optical waveguides 68 5 may be of any type appropriate to deliver the ablative laser radiation required for a particular application. For example, the optical waveguide 68 can be optical fibers connected to an ablative radiation source such as a XeCl excimer laser 10 operating in a pulsed mode at about 308 nanometers.

The use of the catheter system 10A is schematically illustrated in FIGS. 6A-6C. As shown, the catheter and guide wire can be introduced into a 15 blood vessel 16. The walls of the blood vessels are characterized as having an inner endothelium layer 22, a media populated by smooth muscle cells 24 and an outer adventitia 26. In atherosclerotic disease, the endothelium 22 is interrupted by lesions of 20 raised fibers plaque 20. In use, the catheter 10A is positioned next to the obstruction 20 and the ablative radiation source 38 is activated to provide a radiation beam 36 which removes the plaque by photodecomposition. Next, the therapeutic UV 25 radiation source 28 is activated to provide a second beam of radiation 30 which is directed to the smooth muscle cells 40 within the blood vessel media 28 at the angioplasty site 32.

30 Following the therapeutic UV radiation, the catheter can be withdrawn as shown in FIG. 6C, and few smooth muscle cells will remain within the area of the angioplasty injury. By killing a major portion of the smooth muscle cells, the risk of 35 restenosis is again decreased.

As noted above, the therapeutic UV radiation can be provided by a variety of sources, including non-coherent UV light sources and excimer laser sources (e.g., a KrF excimer laser operating at 248 5 nanometers).

In FIG. 7, an alternative laser device 70 is shown which can be used in the present invention to provide the therapeutic UV radiation. In the system 10 70, an output beam from a laser source 48, such as Nd:YAG laser with an output radiation having a wavelength of about 1064 nanometers is introduced via coupler 56 into an optical fiber 54 which is preferably a rare earth-doped silica fiber (e.g. a 15 Neodymium-doped optical fiber). As the radiation from laser source 48 is introduced into the optical fiber 54, the fiber is also optically pumped by an optical pump source 52 (e.g., a laser diode having an output radiation wavelength of about 808 nanometers, 20 likewise coupled to the fiber 54 by coupler 56). The doped optical fiber thus acts a laser amplifier.

At the distal end of fiber 54, the system is terminated in two frequency-multiplying crystals 60 25 and 62. The first crystal 60 is a frequency-doubling optical element, such as a potassium dihydrogen phosphate (KDP) crystal, and the second crystal 62 is also a frequency-doubling optical element, such as a barium boron oxide (BBO) crystal. Focusing optics 30 64, such as a graded refractive index ("GRIN") lens, can be included at the output end of the optical fiber 54. With the system as described, laser radiation of a wavelength of about 266 nanometers is produced.

In the laser device 70 of Fig. 7, the pulsed Nd:YAG laser is chosen for its capability to operate as a rapidly pulsed laser and for its availability at low cost. In particular applications it may be preferred to employ pulsed energy sources other than a Nd:YAG laser. The pulsed laser medium can be gaseous, liquid or solid-state. Rare earth-doped solid state lasers, ruby lasers, alexandrite lasers, carbon dioxide lasers and excimer lasers are all examples of lasers that can be operated in pulsed mode and used as pulse-triggering elements in the present invention.

The laser device 70 is particularly adapted for use within a catheter. In one embodiment, a plurality of optical fibers of the type described herein can be used to provide the needed energy for performing either laser surgery or restenosis preventive therapy. The laser surgical systems of the present invention preferably have an output energy ranging from about 50 millijoules to about 100 millijoules. For a non-ablative, therapeutic application, the systems can be operated at lower output energies, for example, from about 100 microjoules to about 10 millijoules. Other output energies can be employed as needed for particular applications. Likewise, the number of delivery fibers can be varied to adjust the total system output. Moreover, the laser device of Fig. 7 can be incorporated into other surgical tools, such as laser scalpels and/or endoscopes.

The utility of UV radiation in reducing the proliferation of vascular smooth muscle cells has been further demonstrated by experiments. In one set of experiments using cultured cells, the A10 rat embryonic thoracic aorta cell line was obtained from the American Type Culture Collection. This clonal, smooth muscle line was derived from the thoracic aorta of DD1X embryonic rats. The cells possess many of the characteristics of end-stage smooth muscle cells; they produce spontaneous action potential at the stationery phase of growth and exhibit an increase in activity of the enzymes myokinase and creatine phosphokinase.

The cell line was propagated in DMEM medium supplemented with 10% fetal bovine serum and glutamine. These cells were plated on well tissue culture plates. After incubation for three to four days, cells in exponential growth were irradiated using laser radiation of various wavelengths. All of the experiments were run at a laser repetition rate of 10 Hz. The area of cell wall exposed was approximately 9.62 cm². The results are detailed in Table 1 below.

25

TABLE 1

Results of Laser Irradiation
of Smooth Muscle Cells

5

	<u>Laser</u> <u>Wavelength</u>	<u>Energy/</u> <u>Pulse</u>	<u>Exposure</u> <u>Time</u>	<u>Surviving</u> <u>Fraction</u>
10	control	--	--	1.05
	control	--	--	0.95
	266 nm	10 mj	1 min	0.00916
	266 nm	9.6 mj	15 sec	0.0358
15	266 nm	9.9-1.1 mj	1 min	0.114
	355 nm	10.2 mj	1 min	1.12
	1064 nm	>10 mj	1 min	1.03
	266+532+1064	>10 mj	1 min	<0.001
	532+1064	>10 mj	1 min	1.08
20				

These results clearly demonstrate the efficacy of UV radiation in killing aortic smooth muscle cells. Cell cultures exposed to as little as 15 seconds of UV radiation exhibited survival rates 25 below 1 percent.

What we claim is:

1. An apparatus for inhibiting restenosis associated with angioplasty, the apparatus comprising:
 - a catheter adapted for insertion inside a blood vessel and location adjacent to an angioplasty site within the vessel; and
 - UV irradiation means disposed within the catheter for irradiating the angioplasty site with UV radiation having a wavelength ranging from about 250 to about 280 nanometers to kill a portion of smooth muscle cells forming the blood vessel in the vicinity of the angioplasty site thereby reducing susceptibility to restenosis due to blood vessel cell proliferation.
2. The apparatus of claim 1 wherein the catheter further comprises an inflation means disposed within the blood vessel to perform angioplasty.
3. The apparatus of claim 1 wherein the catheter further comprises a second optical waveguide for delivery of ablative laser radiation to plaque at the angioplasty site.
4. The apparatus of claim 1 wherein the UV irradiation means further comprises a laser.
5. The apparatus of claim 4 wherein the UV irradiation means further comprises at least one optical waveguide disposed within the catheter.

6. The apparatus of claim 4 wherein the laser delivers a radiation beam having a wavelength of about 248 to about 268 nanometers.

5 7. An apparatus for performing laser therapy within a subject, the apparatus comprising:
 an elongated flexible tube having a proximal end and a distal end, the distal end being adapted for insertion into a subject;
10 at least one optical fiber disposed within said flexible tube, said fiber adapted to receive energy from an optical pump source at the proximal end, and doped with a lasant material capable of amplifying laser radiation propagating
15 therethrough; and
 at least one frequency-modifying element optically aligned with said fiber and disposed at the distal end of the elongated tube to produce an output beam of laser radiation suitable
20 for laser therapy.

8. The apparatus of claim 7 wherein said lasant material consists of Neodymium.

25 9. The apparatus of claim 7 wherein the apparatus further comprises an input coupler means adapted to receive the optical fiber of said flexible tube and to focus radiation from said optical pump source and a pulsed laser source into the optical
30 fiber.

10. The apparatus of claim 7 wherein the apparatus further comprises a plurality of optical fibers arranged around a guide wire.

5 11. The apparatus of claim 7 wherein said frequency-modifying element is a frequency doubler crystal.

10 12. The apparatus of claim 7 wherein the apparatus further comprises two frequency-doubling crystals disposed at the distal end of the elongated flexible tube.

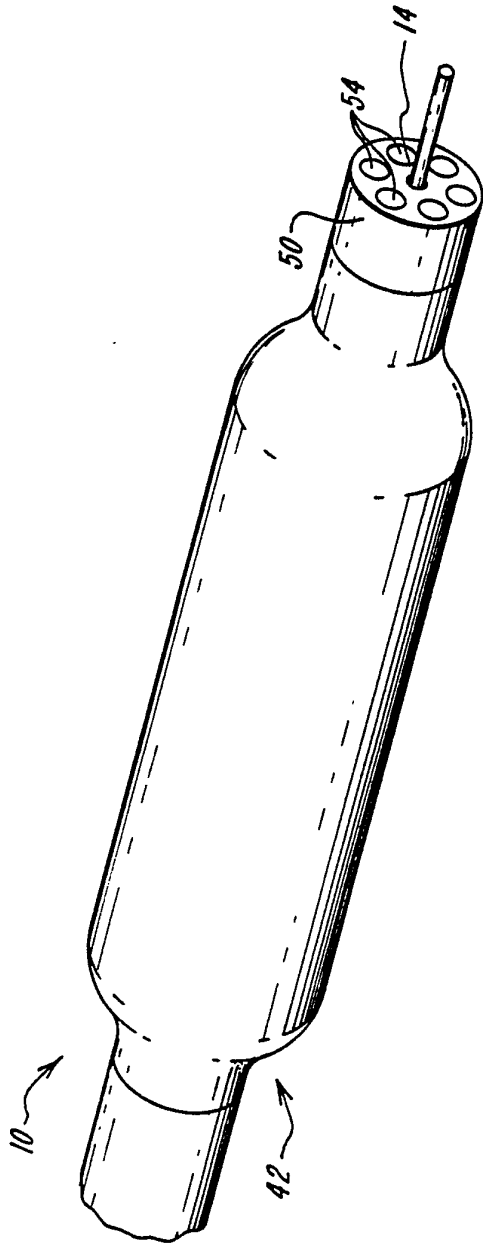

FIG. 1

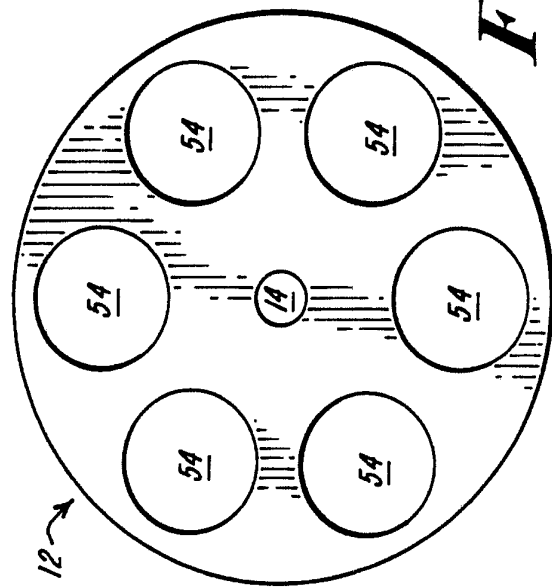

FIG. 2

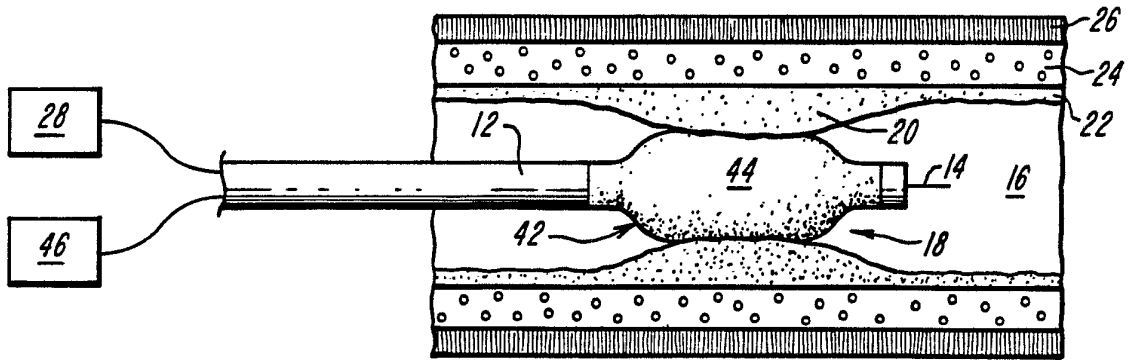

FIG. 3A

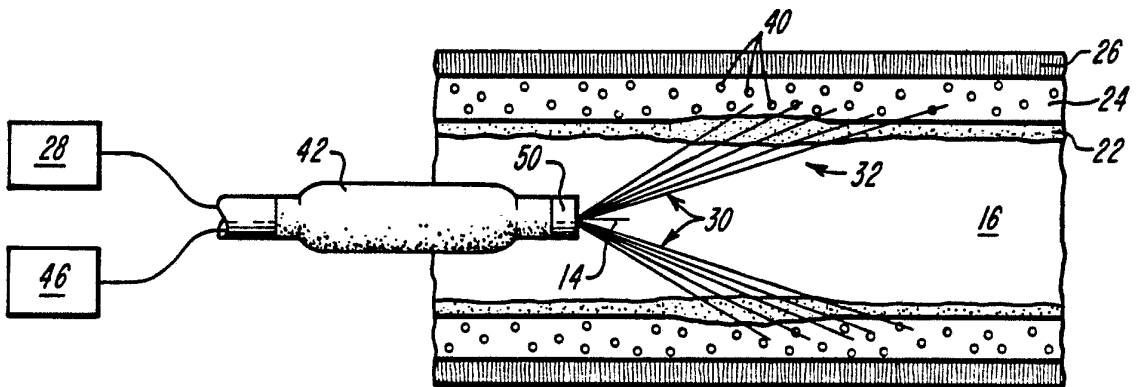

FIG. 3B

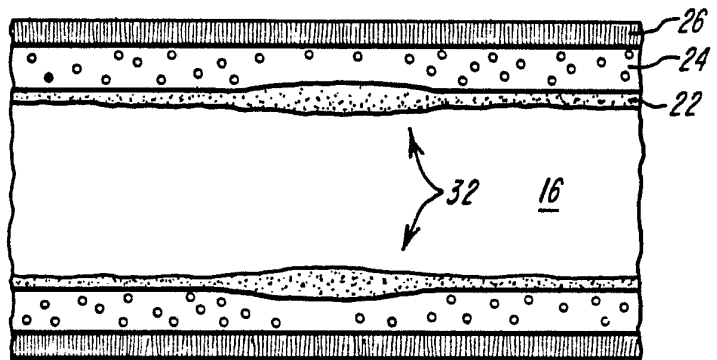

FIG. 3C

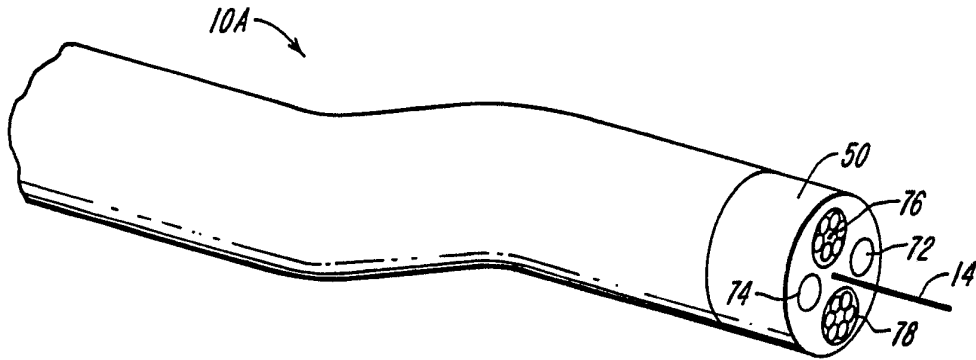

FIG. 4

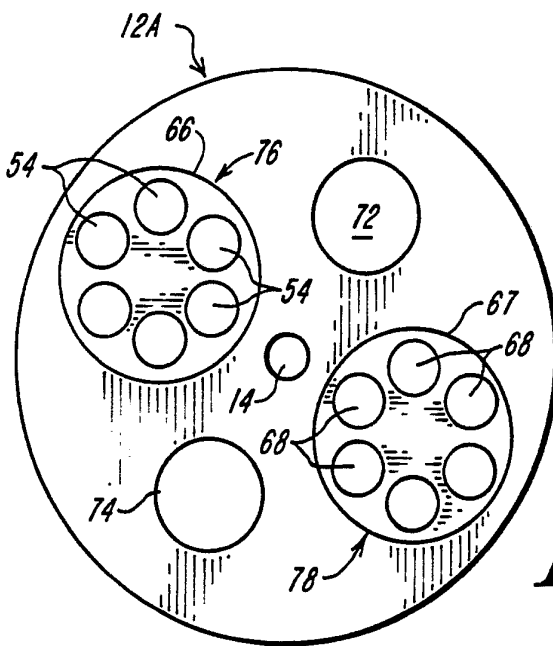

FIG. 5

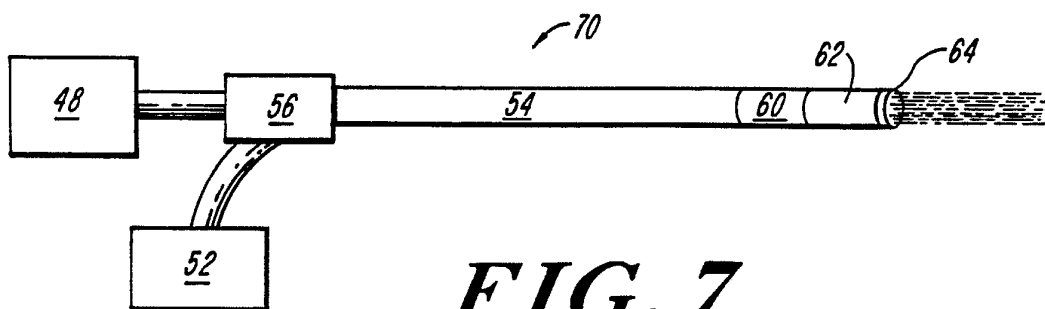

FIG. 7

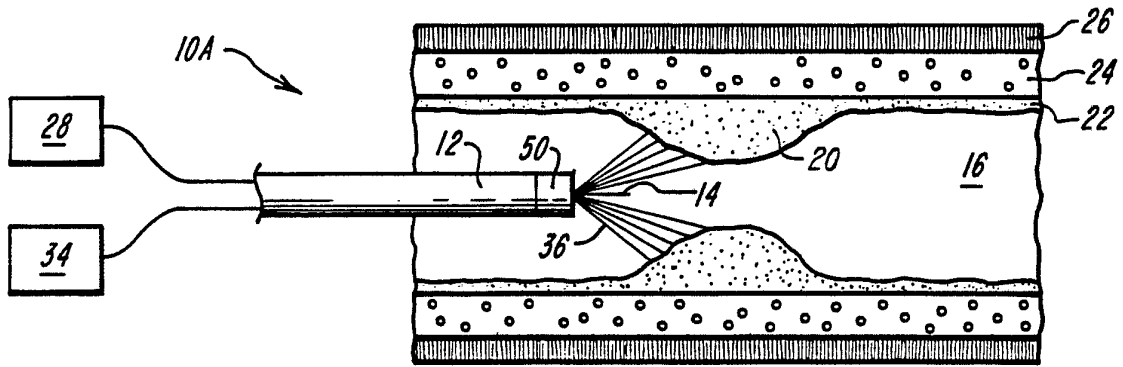

FIG. 6A

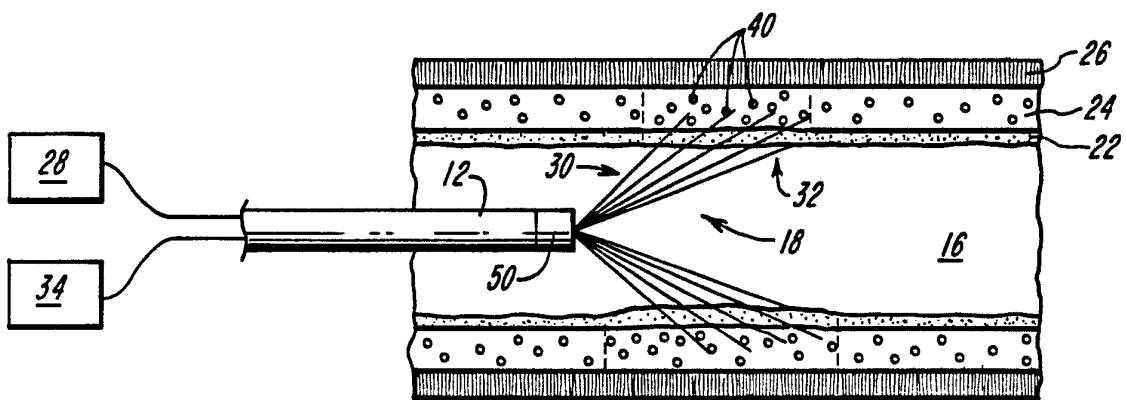

FIG. 6B

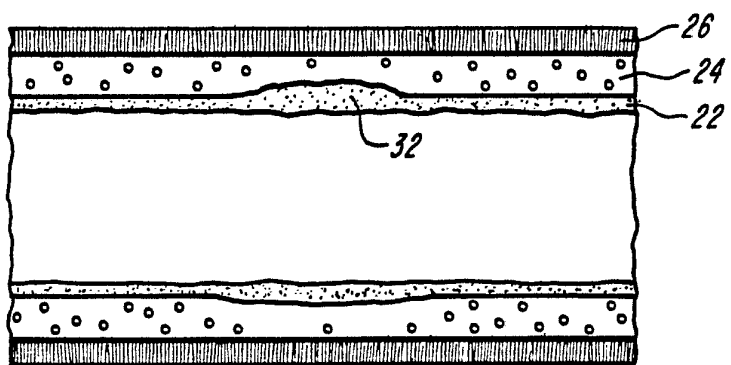

FIG. 6C