

No. 667,903.

Patented Feb. 12, 1901.

C. P. CORNELL.
TROLLEY SWITCH.

(Application filed June 29, 1900.)

(No Model.)

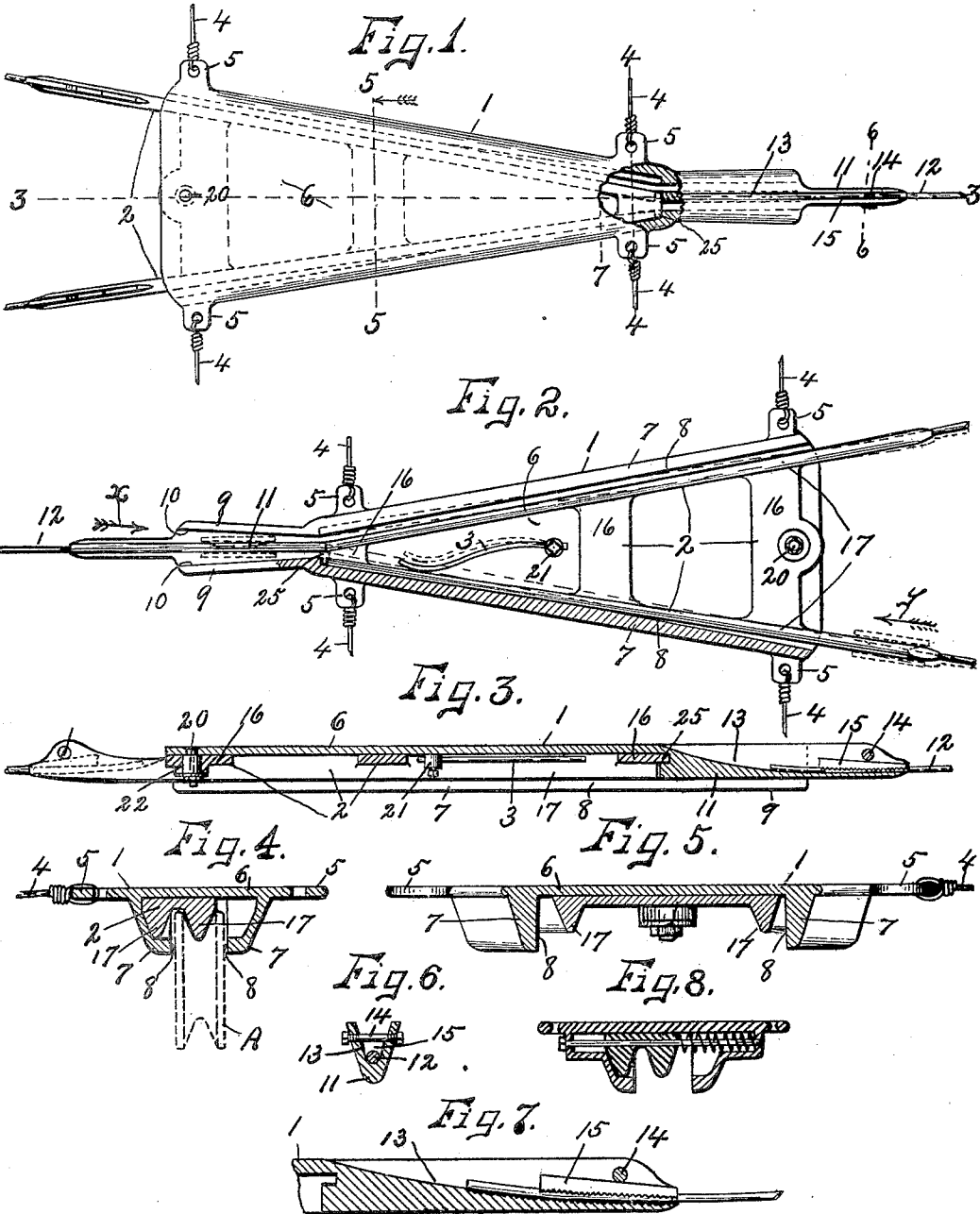

WITNESSES:

J. C. Arthur,
Earle H. Benson

INVENTOR
Charles P. Cornell

BY
Smith & Denison
ATTORNEYS.

UNITED STATES PATENT OFFICE.

CHARLES P. CORNELL, OF BALDWINVILLE, NEW YORK.

TROLLEY-SWITCH.

SPECIFICATION forming part of Letters Patent No. 667,903, dated February 12, 1901.

Application filed June 29, 1900. Serial No. 22,028. (No model.)

To all whom it may concern:

Be it known that I, CHARLES P. CORNELL, of Baldwinsville, in the county of Onondaga, in the State of New York, have invented new and useful Improvements in Trolley-Switches, of which the following, taken in connection with the accompanying drawings, is a full, clear, and exact description.

My invention relates to improvements in trolley-switches, and has for its object the production of a simple and practical device for automatically guiding the trolley from the main conductor to either one of two or more branch conductors of a railway system and for also automatically guiding said trolley from either of said branch conductors to the main conductor; and to this end the invention consists in the construction, arrangement, and combination of the component parts of a switch, as hereinafter fully described, and pointed out in the claims.

In describing this invention reference is had to the accompanying drawings, forming a part of this specification, in which like reference characters indicate corresponding parts in all the views.

Figures 1 and 2 are respectively top plan and inverted plan views, partly broken away, of my improved switch. Figs. 3, 4, and 5 are sectional views taken, respectively, on lines 3 3, 4 4, and 5 5, Fig. 1. Figs. 6 and 7 are enlarged detail sectional views taken, respectively, on lines 6 6 and 7 3, Fig. 1, showing the means for fastening the main and branch conductors to the adjacent portions of my improved switch. Fig. 8 is a transverse section of a portion of my invention, showing a slightly-modified means for holding the movable switch-section in one of its adjusted positions.

This invention is particularly applicable for use with overhead-trolley lines, although the same may be used in connection with sub-surface conductors, if desired, and instead of being used exclusively for electric purposes the same may be used in connection with any tramway in which a trolley is adapted to move in alinement with the main or branch tracks.

The essential elements of novelty of my invention consist, first, in providing a movable switch-section with a plurality of diverging ways; second, pivoting said section in

proximity to the ends of said ways of greatest divergence; third, in providing suitable diverging bearing-faces for engaging the trolley, and thereby shifting the movable section; fourth, in securing the ends of greatest divergence of the ways of the movable section to the branch conductors; fifth, in reversible means for forcing the free end of the movable section in either direction and yieldingly holding said section in one of its adjusted positions, and, sixth, in providing a support for the movable section which serves as a covering or casing for protecting the movable parts from the elements and insuring positive operation of said movable parts.

The invention also consists in other novel elements, as hereinafter fully described.

1 represents a support or casing. 2 is a movable section pivotally connected to the support, and 3 is a reversible spring for yieldingly holding the movable section in one of its adjusted positions.

The support or casing 1 may be of any desired form or construction and is held in position by suitable guys or stay-wires 4, having corresponding ends secured to ears 5, provided on opposite sides of the support 1 and their opposite ends secured to a pole or other means (not illustrated) for holding the support 1 in its proper relative position to the track or tracks. As preferably constructed this support or casing consists of a substantially horizontal wall 6, provided with diverging flanges 7, depending from its opposite longitudinal edges, and formed with inner diverging bearing-faces 8 for engaging the trolley-wheel A. (Illustrated by dotted lines, Fig. 2.) One end of the support or casing is formed with depending flanges 9, forming continuations of the flanges 7 and diverging slightly therefrom toward their outer ends for permitting the trolley to readily enter the switch without liability or injury to either the trolley or any part of said switch. This portion of the support 1 is also provided with a substantially central way, usually consisting of a rib 11, extending beyond the outer ends of the flanges 9 and having its upper face grooved for receiving the main conductor 12. It is thus evident that the rib 11 forms a continuation of the conductor 12 and is usually tapered at its outer extremity to substantially the same

size as said conductor. In order that the conductor 12 may be readily removed or the support 1 quickly and economically placed in position and connected in the main line, I preferably provide said support with a lengthwise groove 13, extending downwardly from its upper face through the outer extremity of the central rib 11, the opposite walls of said groove 13 being provided with apertures for receiving a transversely-arranged bolt 14 and the lower wall of the groove 13 being usually serrated transversely.

The bolt 14 is usually arranged in a plane slightly above the adjacent end of the wire 12, and a wedge 15 is inserted between said bolt and the wire and is provided with a serrated face for engaging said wire, the serrations of the wall of the groove 13 and wedge 15 serving to firmly grip the wire and positively lock the adjacent ends of said wire and the support to each other.

The serrated face of the wedge 15 is preferably formed concave in cross-section for the purpose of engaging as much of the adjacent portion of the wire 12 as possible. When desired to detach the wire 12 and the support 1 from each other, it is simply necessary to remove the wedge, whereupon the wire 12 may be readily removed from the groove 13, it being understood that when the wedge is placed in position the tapering or smaller end is toward the outer end of the central rib 9, thus increasing the grip effect of the wedge when there is any tendency to separate the wire 12 and the support 1 from each other.

The spaces intervening between the central rib 11 and the flanges 9 are preferably just sufficient to permit the easy passage of the flanges of the trolley therethrough, the form of the rib 11 being substantially the same as the groove in the trolley-wheel. The flanges 9 usually extend in a plane beneath the lower face of the rib 11 in order to positively insure the entrance of the trolley to the movable switch-section. This movable switch-section 2, previously mentioned, is mounted upon the support 1 between the flanges 7, is preferably pivoted to one end of the horizontal wall 6 at a point in proximity to and substantially midway between the ends of greatest divergence of the flanges 7, and consists of a substantially horizontal upper wall 16, having portions thereof cut away and having its longitudinal edges provided with diverging ways 17 for receiving and guiding the trolley-wheel. These diverging ways 17, which preferably consist of ribs formed of substantially the same cross-sectional contour as the rib 11 and the groove of the trolley-wheel A, are united to each other by the horizontal wall 16 and are pivoted at 20 to the wall 6 of the support 1. The ribs 17 converge from the pivotal point 20 toward the rib 11, and their free ends are movable automatically and alternately into and out of alinement with said rib 11 as the trolley is moved in opposite directions.

The spaces intervening between the flanges 7 and the ribs 17 are usually just sufficient to receive the flanges of the trolley-wheel and are alternately alined with the spaces between the rib 11 and the bearing-faces 10 in the same manner as the ribs 17 are alternately alined with the rib 11. In order that the rib of the movable section 2 not in alinement with the fixed rib 11 may be entirely out of the path of the moving trolley when said trolley is passing from the main conductor to the branch conductor, or vice versa, portions of the adjacent faces of the flanges 7 are cut away for receiving the free ends of the ribs 17. These free ends of the ribs 17 are so relatively arranged to each other and to the flanges and central rib of the support 1 that when one of the ribs 17 is in alinement with the rib 11 the inner face of the other rib is alined with one of the bearing-faces of one of the flanges 9 and the alined rib is parallel with the adjacent bearing-face of one of the flanges 7.

Any desired means may be employed for automatically forcing the free end of the movable switch-section in one direction and yieldingly holding one of the ribs 17 in alinement with the rib 11. This means is preferably so constructed as to be reversible for the purpose of holding either of the ribs 17 in alinement with said rib 11, as may be desired. As shown in Fig. 2, this means consists of a spring having one end detachably inserted into an aperture formed in a hub 21, projecting from the lower face of the wall 6 of the support 1. The other end of the spring 3 is adapted to engage a portion of the movable section for holding the section in one of its adjusted positions.

When desired, the spring 3 may be detached from the hub 21 and reversed for the purpose of holding the free end of the movable switch-section in its other adjusted position, as shown by dotted lines, Fig. 2.

The means for pivoting the movable switch-section to the support 1 preferably consists of a hub or boss depending from the wall 6 through an aperture 22, formed in the wall 16, said hub having its lower end reduced in diameter and provided with screw-threads adapted to be engaged by a suitable nut for holding the movable section in position.

In order that the free end of the movable switch-section may be held in its proper relation to the support 1, I provide said switch-section with a shoulder 25, projecting beyond the end face of the ribs 17 and lapping upon the adjacent end of the rib 11, as seen in Figs. 2 and 3.

It is apparent from the foregoing description that the free end of the movable switch-section is supported by said shoulder upon the upper face of the adjacent end of the rib 11 and that said section is free to move laterally with but little friction incidental to the engagement of said shoulder with the rib 11.

In the operation of my invention it will be

noted that when the trolley is moving in the direction indicated by arrow *x* along the rib 11 it is free to pass along the rib 17 alined with said rib 11 and thence to the corresponding branch wire secured to said rib. If, on the other hand, the trolley is moving from right to left or from one of the branch wires to the main wire, as indicated by arrow *y*, along the other rib 17, which is normally out of alinement with the rib 11, the flange of the trolley engages the bearing-face of the adjacent flange 7 of the support 1, and thereby automatically forces the free end of the movable section away from said flange and alines said other rib 17 with the rib 11, thereby forcing the opposite rib 17 out of alinement with the rib 11 and into the adjacent recess of the flange 7. After the trolley has forced the free end of the movable switch-section in one direction by the impingement or wedging of the flange of the trolley between one of the bearing-faces of the support 1 and the adjacent rib of the switch-section and said trolley passes on beyond the switch-section the spring 3 automatically returns the switch-section to its former position, previously described.

The operation of my invention will now be readily understood by reference to the foregoing description and the accompanying drawings, and it will be noted that considerable change may be made in the detail construction and arrangement of the parts of my invention without departing from the spirit thereof. Therefore I do not limit myself to the precise construction and arrangement herein shown and described.

Having thus fully described my invention, what I claim as new, and desire to secure by Letters Patent, is—

1. A trolley-switch comprising a support having a fixed way and diverging bearing-faces, and a movable switch-section having diverging ways interposed between said bearing-faces and movable alternately into and out of alinement with the fixed way, said switch-section being shifted in one direction by the engagement of the trolley with one of said bearings and the adjacent way of the switch-section.

2. A trolley-switch comprising a support having a fixed way and flanges diverging from said fixed way, a switch-section movable between said flanges and provided with diverging ways movable into and out of alinement with the fixed way, and yielding means for holding the switch-section in one of its shifted positions, said switch-section being forced to its other shifted position by means of the interposition of one of the flanges of the trolley between one of the flanges and the adjacent way of the switch-section.

3. A trolley-switch comprising a support having a fixed rib and diverging flanges, a main line alined with the fixed rib, and a switch-section pivotally connected to the support between said flanges and having diverg-

ing ribs secured to the branch lines of the switch.

4. A trolley-switch comprising a support having a fixed rib and diverging flanges, a switch-section having one end pivotally connected to the support and provided with ribs converging toward its opposite end and movable alternately into and out of alinement with the fixed rib, and yielding means for holding one of the ribs of the switch-section in alinement with the fixed rib.

5. A trolley-switch comprising a support having one end provided with depending flanges and a substantially central rib and its other end provided with diverging flanges extending beyond said rib, and a switch-section pivotally secured to the support between the diverging flanges and provided with ribs diverging in substantially the same direction as said diverging flanges, a main line or wire detachably secured to one end of the rib of the support, and branch wires or conductors detachably secured to the diverging ends of the ribs of the switch-section, the free ends of the ribs of the switch-section being movable alternately into and out of alinement with the rib of the support.

6. A switch-section comprising a support having one end provided with depending flanges and a fixed substantially central rib, and a switch-section pivotally connected to the support and provided with diverging ribs movable alternately into and out of alinement with the fixed rib, said diverging ribs being so relatively arranged with the flanges and central rib that when one of the diverging ribs is alined with the fixed rib the inner face of the other rib is alined with the inner face of the flanges adjacent thereto.

7. A trolley-switch comprising a support provided with diverging flanges having recesses in their adjacent faces, and a movable switch-section pivotally connected to the support and provided with diverging ribs having their free ends movable alternately into and out of said recesses.

8. A trolley-switch comprising a support having a closed upper wall and diverging flanges depending from said wall, a switch-section interposed between said flanges and having one end pivoted to the upper wall, said switch-section being provided with diverging ribs forming continuations of the branch conductors, and a main conductor, in combination with a trolley-wheel movable along the ribs of the switch-section and adapted to engage the inner face of one of the flanges for forcing the switch-section toward the other flange.

9. A trolley-switch comprising a support provided with a guide and diverging flanges, a rib secured to the support and forming a continuation of the main conductor, and a movable switch-section having one end pivoted to the support and its other end provided with a shoulder movable on said guide, said switch-section being provided with diverging ribs

forming continuations of the branch conductors and being movable automatically by the trolley into and out of alinement with the former rib of the main line.

- 5 10. A trolley-switch comprising a support having one end provided with a fixed rib and flanges extending in a plane beneath and on opposite sides of the fixed rib and its other end provided with diverging flanges formed
10 with recesses in their adjacent faces, a movable switch-section pivoted to the support and provided with diverging ways or ribs movable alternately into and out of alinement

with the fixed rib, said ribs being so relatively arranged to each other that when one of the ribs of the switch-section is alined with the fixed rib, the other rib is forced into the recess of the adjacent flange, and means for automatically holding said switch-section in one of its adjusted positions. 15 20

In witness whereof I have hereunto set my hand this 22d day of June, 1900.

CHAS. P. CORNELL.

Witnesses:

H. E. CHASE,
HOWARD P. DENISON.