

(19) World Intellectual Property Organization
International Bureau



(43) International Publication Date
27 November 2008 (27.11.2008)

PCT

(10) International Publication Number
WO 2008/142160 A1

- (51) International Patent Classification:
G01N 30/60 (2006.01)
- (21) International Application Number:
PCT/EP2008/056369
- (22) International Filing Date: 23 May 2008 (23.05.2008)
- (25) Filing Language: English
- (26) Publication Language: English
- (30) Priority Data:
PCT/EP2007/055008 23 May 2007 (23.05.2007) EP
- (71) Applicant (for all designated States except US): **VRIJE UNIVERSITEIT BRUSSEL** [BE/BE]; Pleinlaan 2, B-1050 Brussel (BE).
- (72) Inventor; and
- (75) Inventor/Applicant (for US only): **DESMET, Gert** [BE/BE]; Tervuursesteenweg 720, B-1982 Elewijt (BE).
- (74) Agent: **BRANTS, Johan Philippe Emile**; De Clercq, Brants & Partners CV, E. Gevaertdreef 10a, B-9830 Sint-Martens-Latem (BE).
- (81) Designated States (unless otherwise indicated, for every kind of national protection available): AE, AG, AL, AM,

AO, AT, AU, AZ, BA, BB, BG, BH, BR, BW, BY, BZ, CA, CH, CN, CO, CR, CU, CZ, DE, DK, DM, DO, DZ, EC, EE, EG, ES, FI, GB, GD, GE, GH, GM, GT, HN, HR, HU, ID, IL, IN, IS, JP, KE, KG, KM, KN, KP, KR, KZ, LA, LC, LK, LR, LS, LT, LU, LY, MA, MD, ME, MG, MK, MN, MW, MX, MY, MZ, NA, NG, NI, NO, NZ, OM, PG, PH, PL, PT, RO, RS, RU, SC, SD, SE, SG, SK, SL, SM, SV, SY, TJ, TM, TN, TR, TT, TZ, UA, UG, US, UZ, VC, VN, ZA, ZM, ZW.

- (84) Designated States (unless otherwise indicated, for every kind of regional protection available): ARIPO (BW, GH, GM, KE, LS, MW, MZ, NA, SD, SL, SZ, TZ, UG, ZM, ZW), Eurasian (AM, AZ, BY, KG, KZ, MD, RU, TJ, TM), European (AT, BE, BG, CH, CY, CZ, DE, DK, EE, ES, FI, FR, GB, GR, HR, HU, IE, IS, IT, LT, LU, LV, MC, MT, NL, NO, PL, PT, RO, SE, SI, SK, TR), OAPI (BF, BJ, CF, CG, CI, CM, GA, GN, GQ, GW, ML, MR, NE, SN, TD, TG).

Declaration under Rule 4.17:

— of inventorship (Rule 4.17(iv))

Published:

- with international search report
- before the expiration of the time limit for amending the claims and to be republished in the event of receipt of amendments

(54) Title: DEVICE FOR THE DISTRIBUTION OF SAMPLE AND CARRIER LIQUID ACROSS A MICRO-FABRICATED SEPARATION CHANNEL

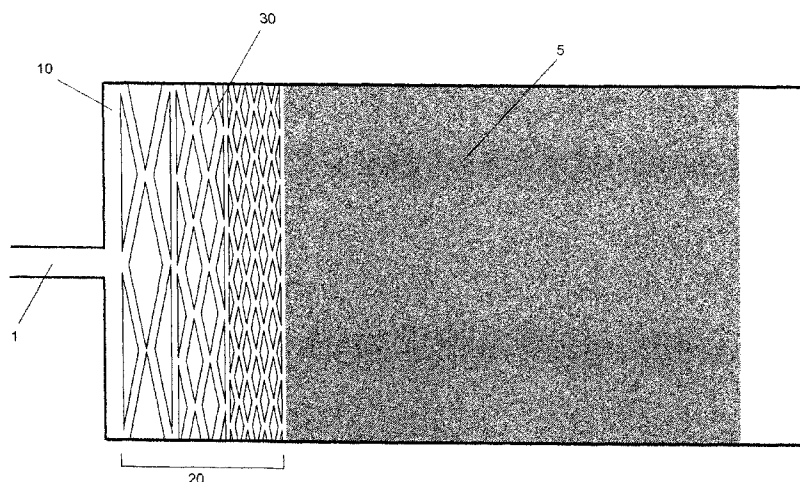

Fig. 1a

(57) Abstract: The present invention relates to a chromatographic separation device comprising a first substrate body carrying a micro-fabricated separation channel recessed on one of its surfaces and covered by a second substrate body, both perforated with connection-holes for the supply and withdrawal of a sample and carrier liquid. The present device is characterized in that said micro-fabricated separation channel is preceded or succeeded by a flow distribution region that is filled with an array of micro-fabricated pillars, having a shape, size and positioning pattern selected such that said flow distribution region has a ratio of transversal to axial permeability of at least 2.

WO 2008/142160 A1

Device for the distribution of sample and carrier liquid across a micro-fabricated separation channel

Technical field

5 The present invention relates to the field of liquid chromatography. The invention provides a device and method for the distribution of sample and carrier liquid across a separation channel.

Background

10 In the art of liquid chromatography, more and more devices are being developed that make use of microfabricated separation channels arranged on the surface of a polymer, silicon or glass wafer. Using etching techniques, said microfabricated separation channels usually have a flat-rectangular cross-section, i.e. are much wider than deep or are much deeper than wide.

To perform and detect a liquid chromatographic separation, said microfabricated separation channels are coupled to a sample injector and to a detector device. Traditionally, this coupling is
15 ensured using a cylindrical connection capillary. The technological challenge surfacing here is that the liquid coming from a round tubing with limited diameter should be spread uniformly over the cross-section of said microfabricated separation channel without creating excessive band broadening or axial dispersion. Similarly, it is also important that at the end of the separation channel a distribution zone is arranged to make the transition between the flow in the flat-
20 rectangular separation channel and the circular tubing needed to lead the sample towards an off-chip detector. If performing liquid chromatography, this transition should occur with a minimum of band broadening. One of the general engineering rules that can be used for the design of these flow distribution structures is that they should have a small total volume, for the band broadening or axial dispersion of a device is generally proportional to its volume.

25 With this in mind, a solution to disperse the liquid across a microchannel proposed in Sant et al. (2006, Reduction of End Effect-Induced Zone Broadening in Field-Flow Fractionation Channels, Anal. Chem., online publication A-H), and making use of a triangular distribution region with an opening angle between 60 and 90 degrees, has the clear drawback that it would occupy a too large volume if the ratio of separation channel width to inlet channel width is large. For example,
30 if the separation channel would be 1 cm wide, the length of the distribution triangle in the case of 90 degree opening angle a would also have to be 1 cm. The continuously bifurcating channel inlet proposed in US patent N° 6,156,273 also makes use of such a diverging channel inlet or outlet.

35 There is a need in the art for providing a device for the distribution of sample and carrier liquid across a micro-fabricated separation channel, which overcomes at least some of the above-indicated drawbacks.

Summary

The present invention provides a device for the distribution of sample and carrier liquid in a micro-fabricated separation channel, wherein dispersion or permeability of the sample and carrier liquid across said separation channel is improved. In particular, the invention provides a device in which flow distribution zones are designed, wherein the lateral dispersion or permeability is promoted so as to become larger than the axial dispersion or permeability. Given that the incoming liquid needs to be spread in the lateral direction across the channel cross-section, such design is much more advantageous. It is noted that the flow distribution structures proposed in US patent 6,156,273 and Sant et al. (2006) is that they have a lateral dispersion that is smaller than their axial dispersion.

Thereto, in all embodiments according to the present invention, a device is provided wherein flow distribution regions are developed that are filled, preferably over their entire depth, with an array of micro-fabricated pillars having a shape, size and positioning pattern selected such that said flow distribution region has a ratio of transversal to axial permeability of at least 2.

This permeability ratio can for example be calculated using computational fluid dynamics software to calculate the pressure drop of a flow progressing through the distribution region in the axial direction and comparing that with the pressure drop of a flow progressing through the distribution region in the transversal direction with the same mean velocity. The ratio of both pressure drops is then the inverse of the permeability ratio.

Description of the drawings

Figure 1a is a top view of a separation channel being arranged with one of the flow distribution regions according the present invention.

Figure 1b illustrates examples of micro-pillar shapes with a suitable lateral width to axial width ratio.

Figure 2 is a top view of one of the flow distribution regions according the present invention, consisting of pillars with a size and/or inter-pillar distance that varies in the lateral direction.

Figure 3 is a longitudinal cross-sectional view of one of the flow distribution regions according the present invention, wherein at least one part of the flow distribution region is etched to a lesser depth than said separation channel.

Figure 4 is a longitudinal cross-sectional view of a device according to the present invention wherein a flow distribution region is arranged on a surface different from the surface carrying the separation channel.

Figure 5 is a longitudinal cross-sectional view of a device according to the present invention wherein two different flow distribution regions are connected to different inlet reservoirs.

Figure 6a-b illustrate a top view of one of the flow distribution regions according the present invention having parallel running separation walls and connected to different (Fig 6a) inlet or (Fig 6b) outlet channels.

Figure 7a-b are top view CCD-camera images, obtained by looking through the glass cover plate, of a fluorescent coumarine tracer distributed across an array of cylindrical micro-pillars using a flow distribution region according to the present invention (Fig. 7a) and using a continuously bifurcating inlet system (fig. 7b, prior art).

Detailed description of the invention

The present invention relates to a flow distribution region designed to spread a liquid uniformly across the lateral width of a flat-rectangular separation channel containing a separation medium. Said separation medium can be another micro-pillar array, a bead packing, a monolithic support or any other suitable chromatographic medium.

The terms "*distribution*" and "*dispersion*" are used herein in some embodiments as synonyms and refer to the spatial property of being scattered about over an area or volume.

The term "*permeability*" as used herein refers to the rate of flow of a liquid through a material, preferably across a micro-fabricated separation channel as defined herein.

In a first embodiment the invention provides a chromatographic separation device comprising a first substrate body carrying a micro-fabricated separation channel recessed on one of its surfaces and covered by a second substrate body, both perforated with the necessary connection-holes for the supply and withdrawal of the sample and mobile phase liquid, characterized therein that said micro-fabricated separation channel is preceded or succeeded by a flow distribution region that is filled from bottom to top with an array of micro-fabricated pillars having a shape, size and positioning pattern selected such that said flow distribution region has a ratio of transversal to axial permeability of at least 2. Preferably, the invention relates to a chromatographic separation device comprising a first substrate body carrying a micro-fabricated separation channel recessed on one of its surfaces and covered by a second substrate body, whereby said first and said second substrate body are both perforated with inlet and outlet connection-holes for the supply and withdrawal of a sample and carrier liquid, characterized in that said micro-fabricated separation channel is preceded or succeeded by a flow distribution region that is filled with an array of micro-fabricated pillars, whereby said pillars have a shape, size and positioning pattern selected such that said flow distribution region has a ratio of transversal to axial permeability of at least 2.

In a preferred embodiment, said flow distribution region has a substantially uniform lateral width, said width being equal to the width of said separation channel.

In another embodiment, a device is provided wherein said micro-fabricated pillars have a diamond-like or ellipsoidal shape. Preferably said micro-fabricated pillars have a ratio of lateral
5 width to axial width that is larger than $3/2$.

In a preferred embodiment, the invention relates to a device wherein said micro-fabricated pillars are arranged in different zones of different pillar sizes, whereby said different zones are arranged in a substantially monotonic order from the zone containing the smallest pillars to the zone containing the largest pillars, and whereby the zone containing the largest pillars is
10 arranged closest to the inlet or outlet connection hole of said substrate body.

Even more preferred, a device is provided wherein said micro-fabricated pillar zone having the largest pillars is adjacent to an open zone devoid of pillars. Said open zone preferably has a width of 1 to 20 μm .

Fig. 1a shows an embodiment of a flow distribution region according to the present invention and preceding a separation channel filled with a separation medium 5, comprising a short open
15 region 10, constituting a flow domain wherein the resistance against the flow in the lateral direction is minimal, preferably 1 to 10 μm wide and being directly connected to the inlet orifice 1, followed by a flow distribution region 20 according to the present invention comprising micro-machined pillars 30 having a ratio of lateral width 31 to axial width 32 (**Fig. 1b**) that is larger
20 than $3/2$ and sufficiently closely packed to induce a lateral permeability that is at least 2 times larger than the axial permeability. In a preferred embodiment, said micro-machined pillars are arranged in order of decreasing size, with the largest pillars closest to the inlet orifice 1 of the substrate body carrying said separation channel. At the channel outlet, the different regions making up the flow distribution regions should be arranged in an opposite order, starting with
25 the smallest flow distribution pillars and ending with the open region.

Fig. 1b shows a top view of a number of the possible micro-fabricated pillar shapes that can be effective for use in the flow distribution region(s) according to the present invention. The terms "micro-fabricated" or micro-machined are used herein as synonym. Methods to produce the
30 desired micro-pillars are well-known to those skilled in the art of micromachining, and are for example Bosch etching or LIGA replication. Substrates suitable to produce the micro-pillars are for example glass wafers or silica wafer. The terms "micro-pillar" or "pillar" as used herein refer to structures that have been fabricated using a micromachining technique.

In another embodiment, the invention provides a device wherein the size and the inter-pillar distance of said micro-pillars is varied in lateral direction. To promote a further good lateral
35 distribution of the liquid, it also one of the aspects of the present invention to provide a pattern

of pillars with a size and/or inter-pillar distance that varies in the lateral direction so as to have a flow distribution region having a lower flow resistance in the lateral channel parts that are most remote of the inlet and/or outlet orifices. Such embodiment is for instance illustrated on **Fig. 2**.

5 In yet another preferred embodiment, at least one part of the flow distribution region has a lesser depth than said separation channel, i.e. it is etched to a lesser depth than said separation channel. **Fig. 3** shows such an embodiment, wherein the open region 10a and a first part of the flow distribution region 20a is etched to a significantly lesser depth than the separation channel containing the separation medium 5 and the second part of the flow distribution region 20b, preferably also preceded by an open region 10b. The advantage of this embodiment is that a
10 further reduction of the volume of the flow distribution region is created. In some embodiments according to the present invention, said deeper etched second part 20b can be omitted. In some case however, a particular advantage of deeper etched second part 20b of said flow distribution can be obtained by selecting the pillar sizes and inter-pillar dimensions such that the axial permeability of said second part is very low. This will help to induce a convective flow in the
15 open region 10b that runs essentially in the downward direction, hence promoting the mixing across the depth of the separation channel.

In another embodiment, the invention provides a device, wherein at least one part of the flow distribution region is arranged on a different surface than the surface carrying said separation channel. The present invention is not limited to flow distribution regions that are arranged on the
20 same surface as the surface carrying said separation channel. As represented in **Fig. 4**, the use of a perpendicularly etched connection channel 25 allows at least a part of the flow distribution region 20a to be arranged on either the surface of the substrate body 40 carrying the separation channel filled with the separation medium 5 (opposite to the surface carrying the separation channel), or on one of the surfaces of the substrate body 60 used to close off the separation
25 channel. The advantage of these embodiments is that the perpendicular running connection channel 25 will induce a perpendicular flow to the separation channel, hence promoting mixing in the depth of the channel.

In another embodiment according to the present invention, a device may be provided wherein at least two different flow distribution regions are present at a different surface and are connected
30 to a different liquid reservoir. Multiple inlet flows coming from different fluid reservoirs can be used. For example, as represented on **Fig. 5**, one inlet flow is provided that feeds a first distribution region 20a, and a second inlet flow is provided that feeds a second distribution region 20b, and that enters the separation device via a second inlet orifice 70 machined in a third substrate 80 used to close off the second distribution region 20b (**Fig. 5**). The advantage of
35 this embodiment is that the sample to be separated can be sent through a flow distribution region that is smaller -hence creating less band broadening- than the flow distribution region

used for the main mobile phase flow or carrier fluid. Both separate inlet flows can be organized alternately or simultaneously.

In yet another embodiment according to the present invention, a device is provided, wherein said flow distribution region is provided with one or more impermeable thin walls, which at least partly divide said flow distribution regions in two or more sections, said walls being provided parallel with the mean flow direction, and wherein preferably said sections are each connected to a different in- or outlet channel. For instance, the flow distribution region is at least partly divided using n impermeable thin walls 800, n being larger than 1, running parallel with the mean flow direction and hence preventing the communication between different lateral parts of the flow distribution region. **Fig. 6a** illustrates how this approach can be used to feed the sample to the central part of the channel only, using separate feeding channels 81, 82 and 83. **Fig. 6b** illustrates how this approach can be used to feed the liquid running through the central part of the channel exclusively to the detector device using a first outlet channel 91, while the liquid flowing closest to the channel side walls is evacuated to the waste using a second and a third outlet channel 92 and 93. Arranging said flow dividing impermeable walls into the flow distributor region is especially advantageous because the flow distributor will anyhow also limit the band broadening induced by the transition between the broad separation channel and the narrow in- and outlet channels and also because the high flow resistance of the distributor regions according to the present invention allows alleviating the influence of differences in flow resistance among the parallel inlet channels or among the parallel outlet channels by making the flow resistance of said parallel inlet and outlet channels negligible compared to the flow resistance of the flow distributor region.

Limiting the injection and detection of species to the central region of the channel can be expected to be very advantageous if the flow distributing device itself functions improperly and leads to a warped velocity profile 100. In this case it would be advantageous to only inject and/or detect in the central part of the channel, where the warp of the velocity profile will anyhow be much smaller than near the side-walls. It will also be very advantageous to circumvent the side-wall dispersion problem described in Broeckhoven and Desmet (*Journal of Chromatography A*, 1172 (2007), 25-39).

The present invention further relates to a method for controlling dispersion and/or permeability of a sample and carrier liquid across a micro-fabricated separation channel having inlet and outlet connection-holes for respectively the supply and the withdrawal of said sample and carrier liquid, said method comprising inducing a lateral permeability that is larger than an axial permeability. Preferably, said method comprises inducing a lateral permeability that is at least 2 times larger than said axial permeability. The present method is carried out by providing in the front of, or in the back of said micro-fabricated separation channel a flow distribution region that

is filled with an array of micro-fabricated pillars. Said pillars have a shape, size and positioning pattern as defined herein and selected such that said flow distribution region provides a ratio of transversal to axial permeability of at least 2.

5 In another embodiment, the invention provides a method for controlling flow dispersion or permeability of a sample and carrier liquid across a micro-fabricated separation channel comprising inducing in the lateral parts of said separation channel that are most remote of said connection holes a lower flow resistance. This embodiment can be obtained by adapting shape, size, positioning pattern, and/or inter-pillar distance of said micro-pillars in the lateral direction of said micro-fabricated separation channel.

10 The invention further provides a method comprising separately controlling the permeability (dispersion) of said sample and said carrier liquid.

Fig. 7 shows top view CCD-camera images comparing the band broadening obtained with a flow distribution region according to the present invention and being composed of diamond pillars with a lateral width that is 10 times larger than the axial width and therefore having a ratio of transversal to axial dispersion larger than two (Fig. 7a) with the band broadening obtained in a continuously bifurcating inlet system as for example disclosed in US patent N° 6,156,273 (fig. 7b, prior art). The band in Fig. 7a is clearly narrower and less distorted than that in Fig. 7b. The distortions of the band in Fig. 7b are caused by the fact that any band distortion originating from a difference in flow resistance, caused by inevitable small etching errors, between the branches of a bifurcating channel system can not be corrected in the remainder of the inlet system since the different branches of the bifurcating inlet are not transversally interconnected. The flow distributors according to the present invention on the other hand are designed such that they promote lateral mixing and therefore allow the immediate correction, through lateral mixing, of small band distortions.

15

20

Claims

1. A chromatographic separation device comprising a first substrate body carrying a micro-fabricated separation channel recessed on one of its surfaces and covered by a second substrate body, whereby said first and said second substrate body are both perforated with inlet and outlet connection-holes for the supply and withdrawal of a sample and carrier liquid, characterized in that said micro-fabricated separation channel is preceded or succeeded by a flow distribution region (20) that is filled with an array of micro-fabricated pillars, whereby said pillars have a shape, size and positioning pattern selected such that said flow distribution region has a ratio of transversal to axial permeability of at least 2.
2. A device according to claim 1, wherein said flow distribution region has a substantially uniform lateral width that is equal to the width of said separation channel.
3. A device according to claim 1 or 2, wherein said micro-fabricated pillars have a diamond-like or ellipsoidal shape.
4. A device according to any of claims 1-3, wherein said micro-fabricated pillars have a ratio of lateral width to axial width that is larger than $3/2$.
5. A device according to any of claims 1-4, wherein said micro-fabricated pillars are arranged in different zones of different pillar sizes, whereby said different zones are arranged in a substantially monotonic order from the zone containing the smallest pillars to the zone containing the largest pillars, and whereby the zone containing the largest pillars is arranged closest to the inlet or outlet connection hole of said substrate body.
6. A device according to any of claims 1-5, wherein said micro-fabricated pillar zone having the largest pillars is adjacent to an open zone devoid of pillars.
7. A device according to claim 6, wherein said open zone has a width of 1 to 20 μm .
8. A device according to any of claims 1-7, wherein the size and the inter-pillar distance of said micro-pillars is varied in lateral direction.
9. A device according to any of claims 1-8, wherein at least one part of the flow distribution region has a lesser depth than said separation channel.

10. A device according to any of claims 1-9, wherein at least one part of the flow distribution region is arranged on a surface which is different from the surface carrying said separation channel.
- 5 11. A device according to any of claims 1-10, wherein at least two different flow distribution regions are provided on different surfaces and whereby said different flow distribution regions are connected to different liquid reservoirs.
- 10 12. A device according to any of claims 1-11, wherein said flow distribution region is provided with one or more impermeable thin walls, which at least partly divide said flow distribution regions in two or more sections, said walls being provided parallel with the mean flow direction, and wherein said sections are each connected to a different in- or outlet channel.

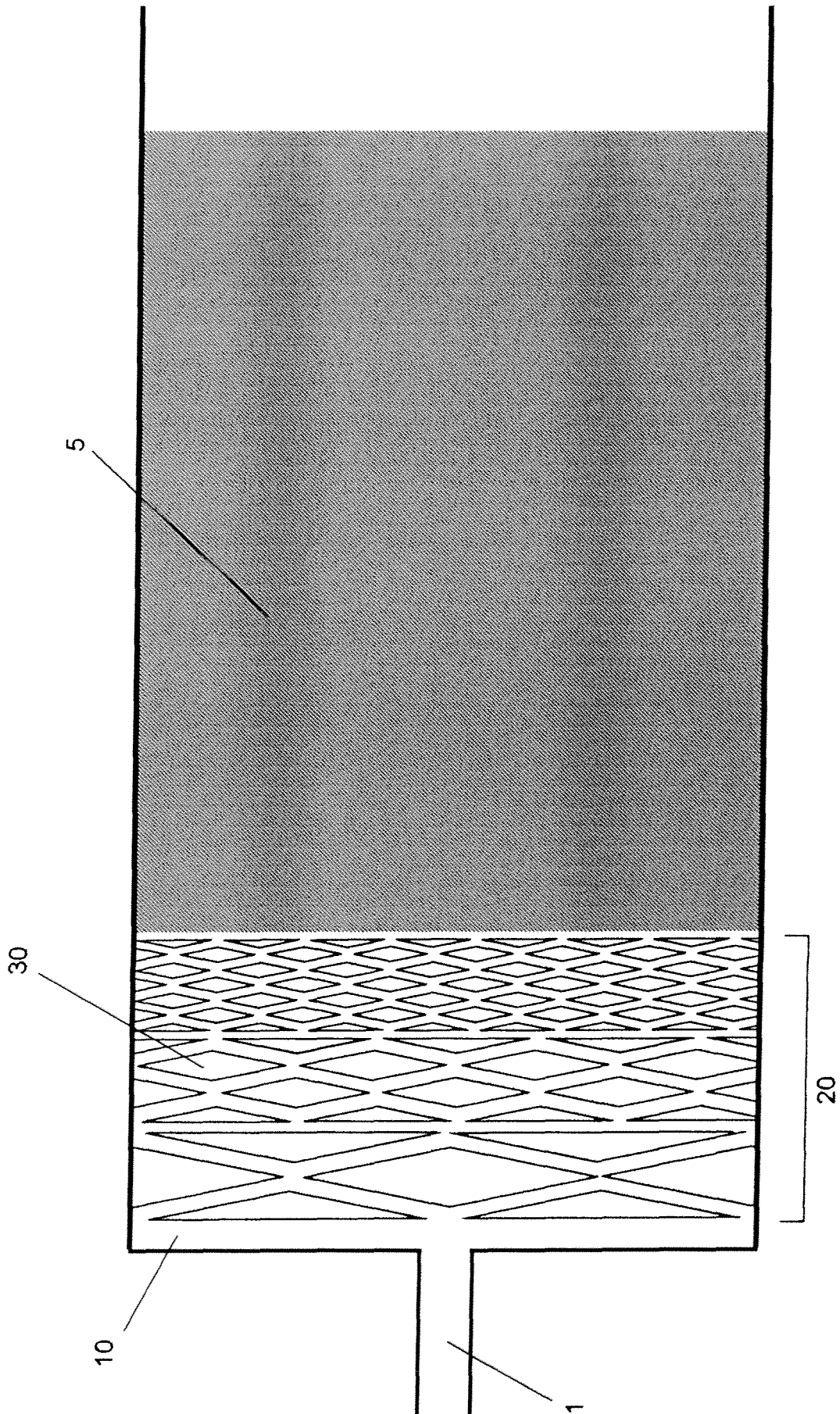

Fig. 1a

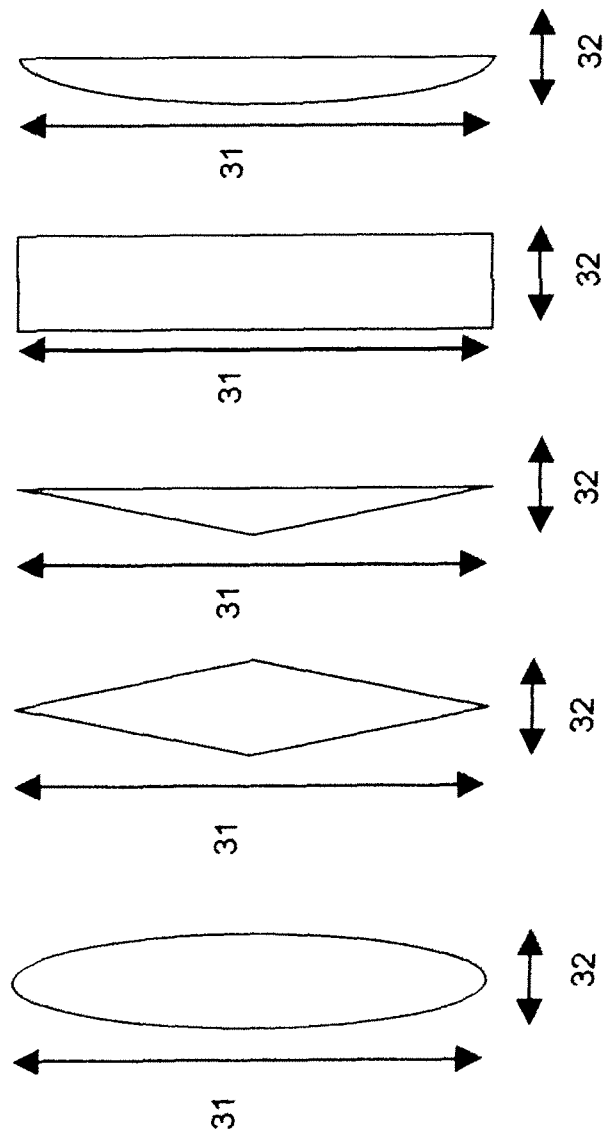

Fig. 1b

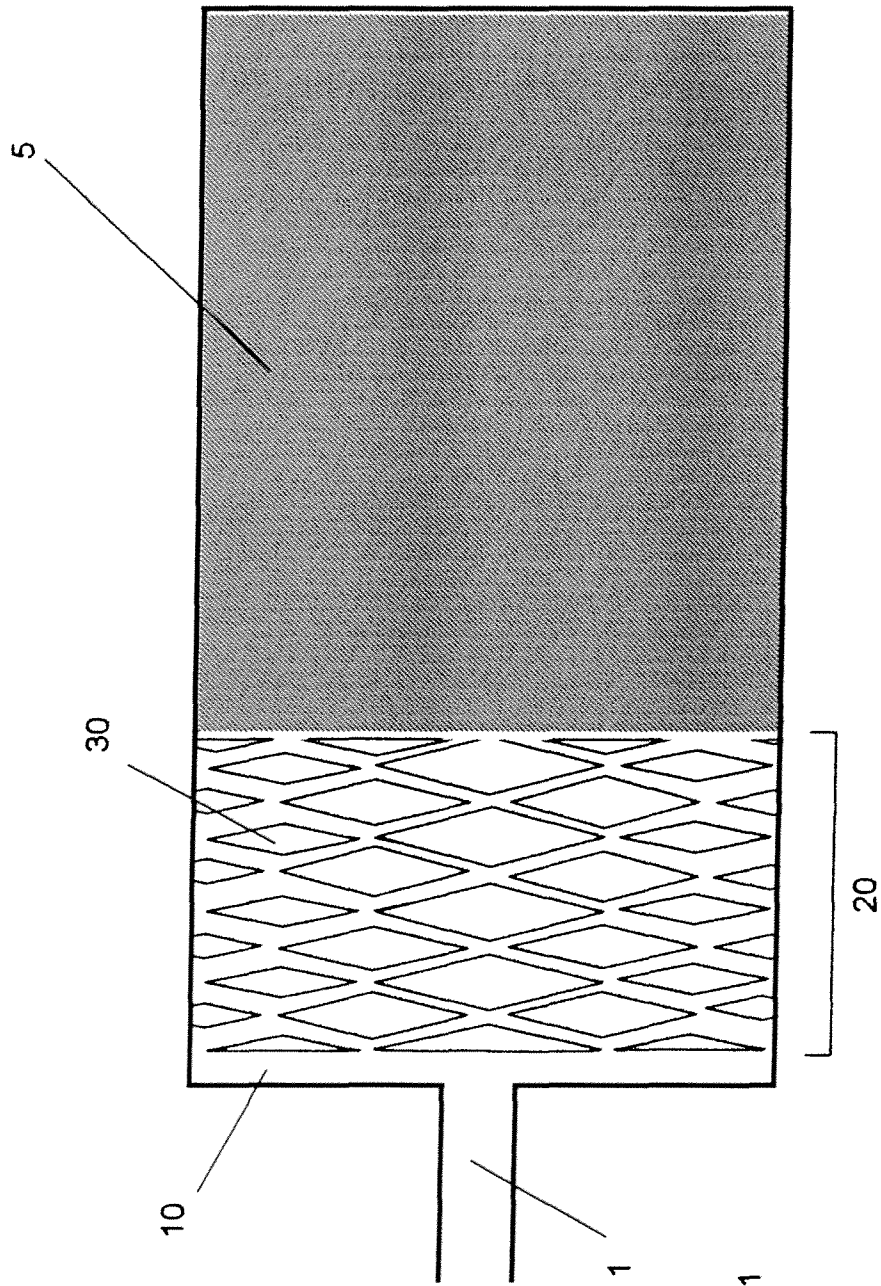

Fig. 2

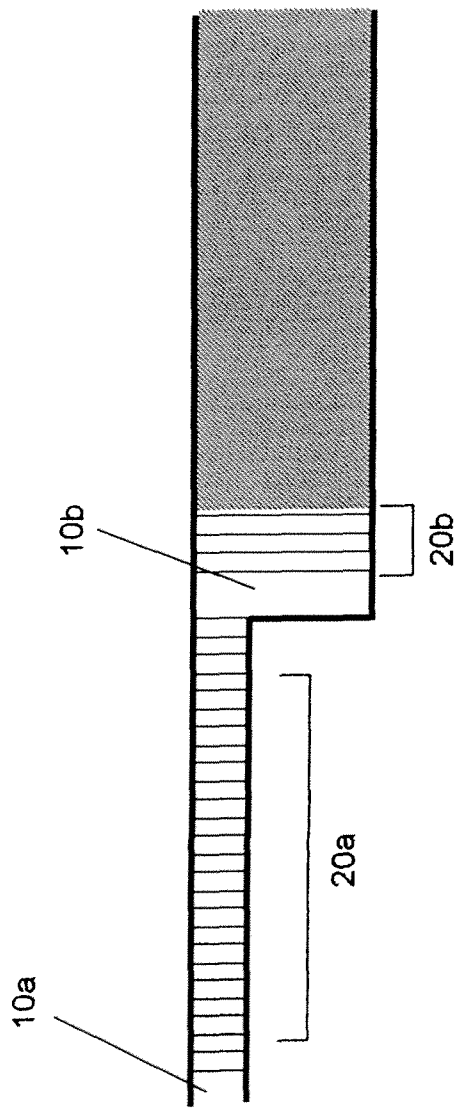

Fig. 3

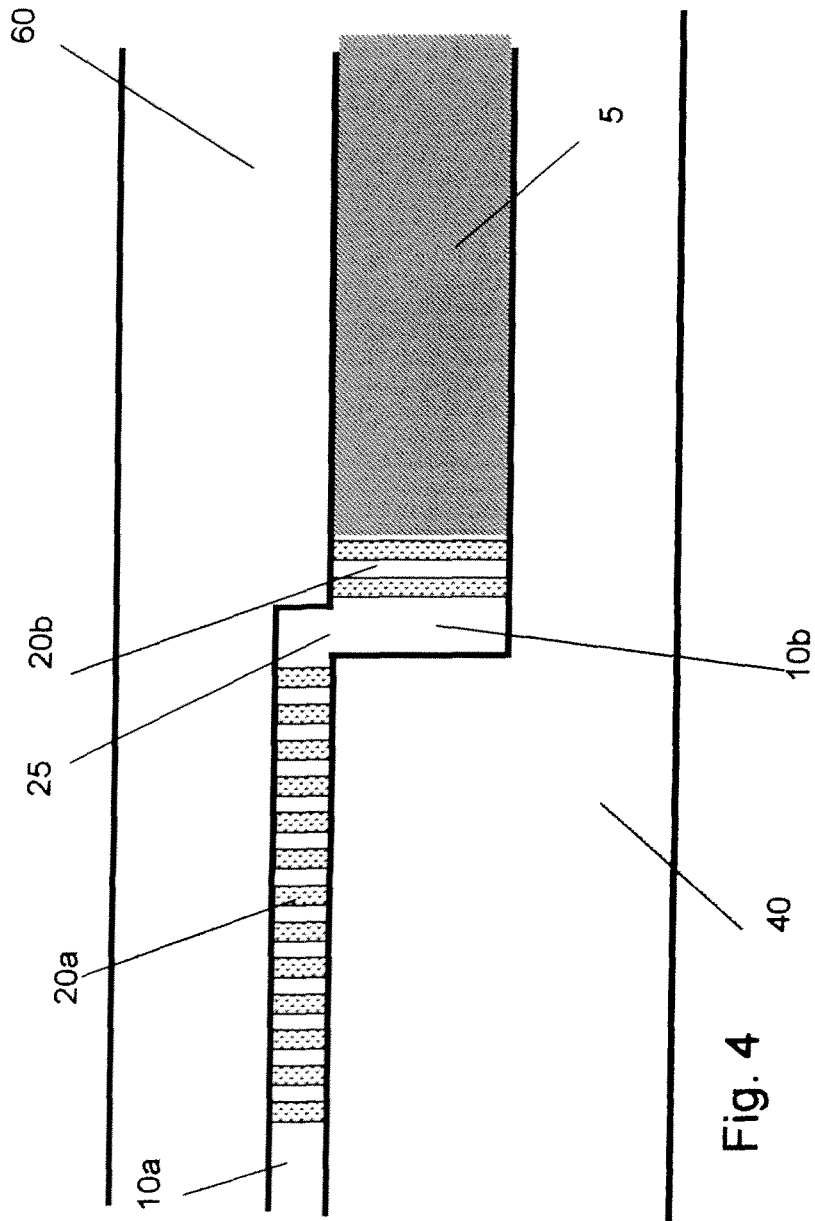

Fig. 4

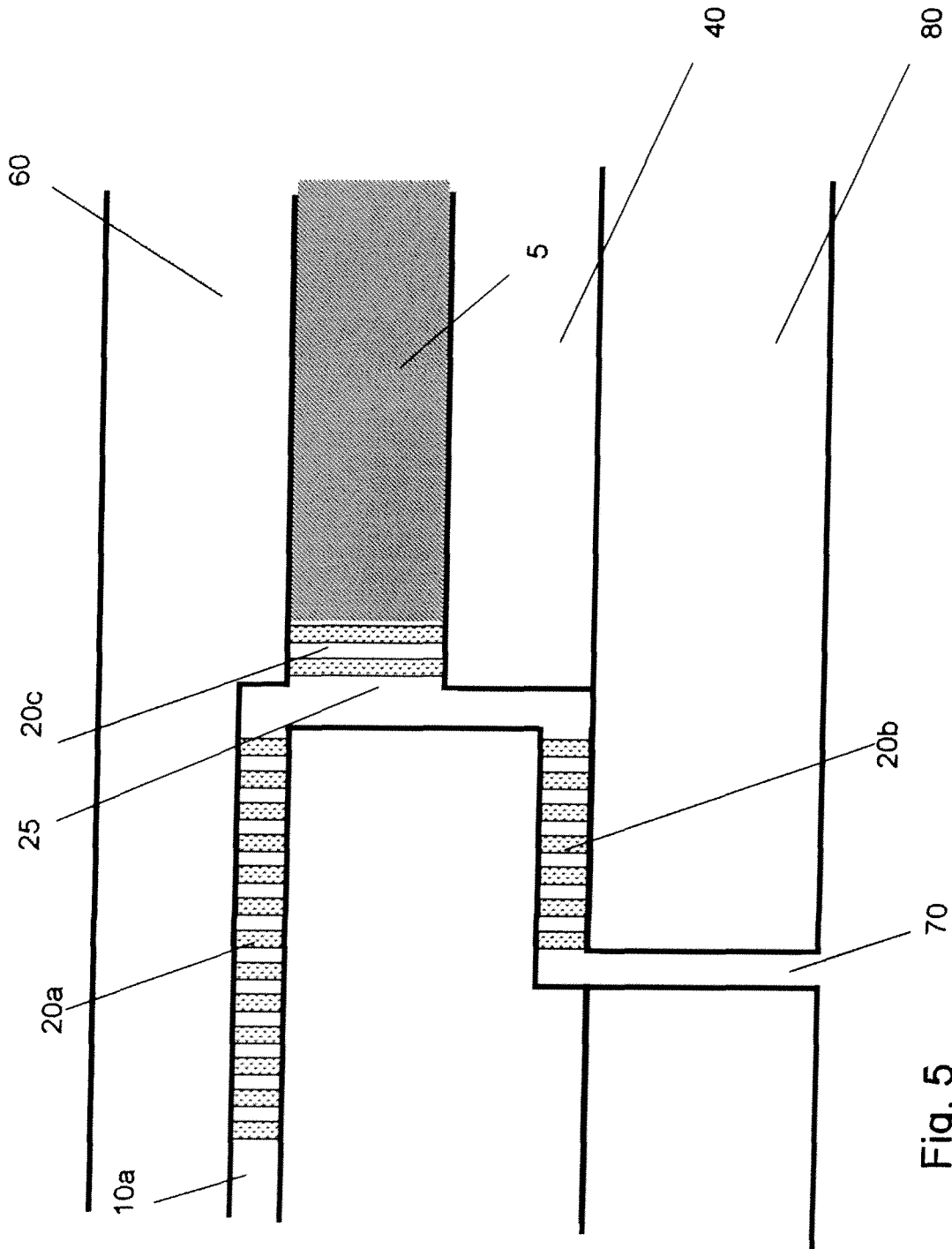

Fig. 5

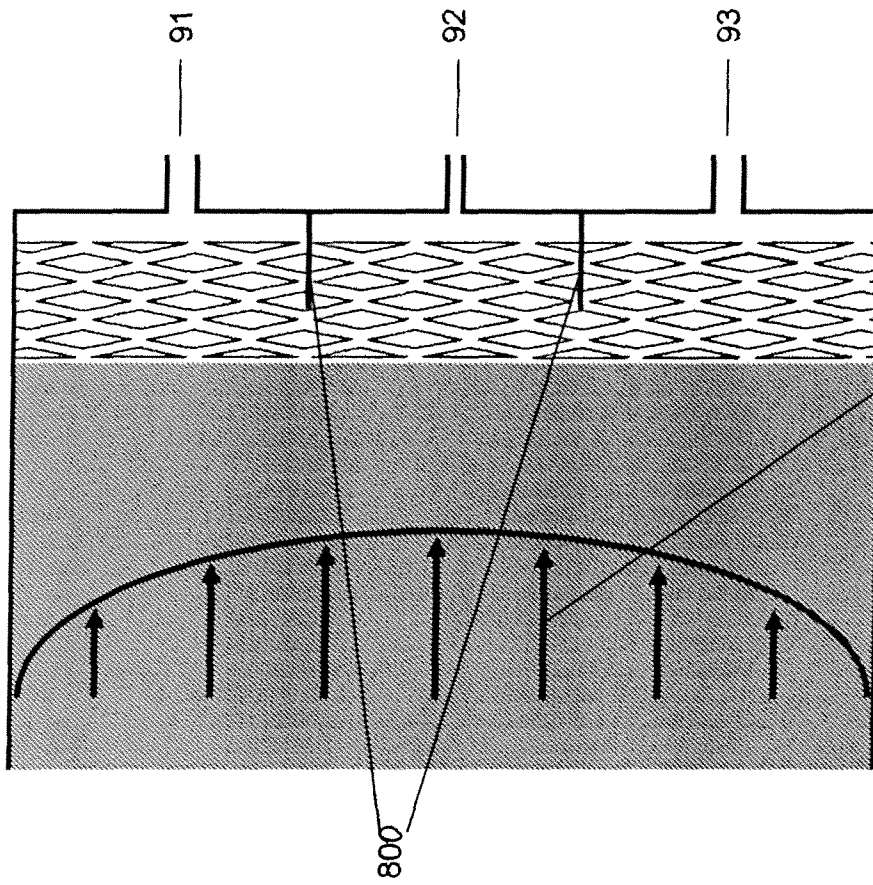

Fig. 6b

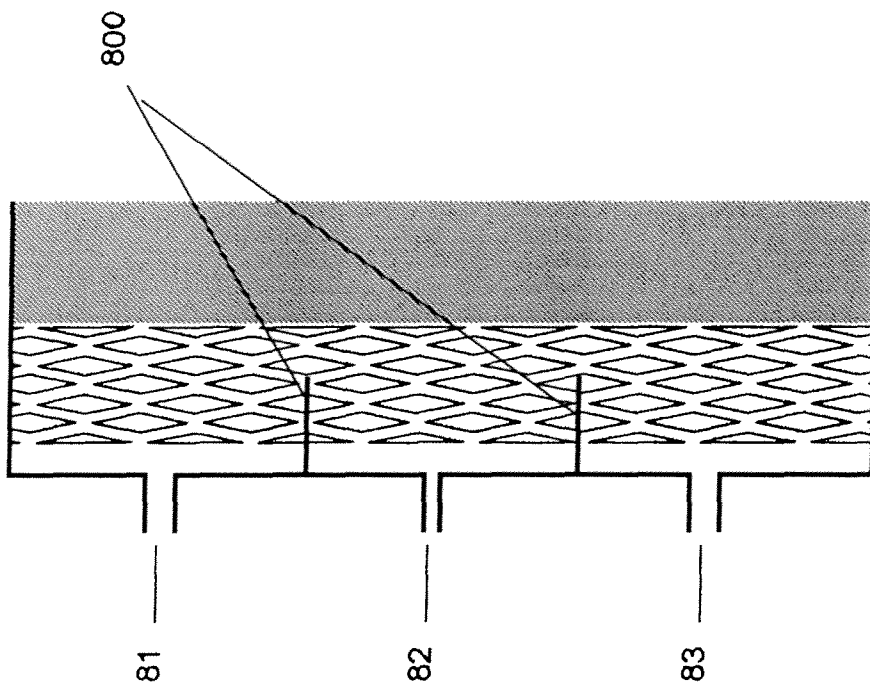

Fig. 6a

INTERNATIONAL SEARCH REPORT

International application No
PCT/EP2008/056369

A. CLASSIFICATION OF SUBJECT MATTER INV. G01N30/60				
According to International Patent Classification (IPC) or to both national classification and IPC				
B. FIELDS SEARCHED				
Minimum documentation searched (classification system followed by classification symbols) G01N				
Documentation searched other than minimum documentation to the extent that such documents are included in the fields searched				
Electronic data base consulted during the international search (name of data base and, where practical, search terms used) EPO-Internal, WPI Data				
C. DOCUMENTS CONSIDERED TO BE RELEVANT				
Category*	Citation of document, with indication, where appropriate, of the relevant passages	Relevant to claim No.		
A	EGHBALI HAMED, DE MALSCHE WIM, CLICQ DAVID, GARDENIERS HAN, DESMET GERT: "Pressure-driven Chromatography in Perfectly Ordered Pillar Array Columns" LC-GC EUROPE, [Online] 1 April 2007 (2007-04-01), pages 1-11, XP002496763 Retrieved from the Internet: URL:www.lcgceurope.com> [retrieved on 2008-09-11] page 1, paragraph 1 - paragraph 2 page 3, paragraph 3 - page 4, paragraph 2 page 6, paragraph 3 - paragraph 5 figures 1-3 ----- -/--	1-12		
<input checked="" type="checkbox"/> Further documents are listed in the continuation of Box C.				
<input checked="" type="checkbox"/> See patent family annex.				
Special categories of cited documents:				
<table style="width: 100%; border: none;"> <tr> <td style="width: 50%; border: none; vertical-align: top;"> <ul style="list-style-type: none"> *A* document defining the general state of the art which is not considered to be of particular relevance *E* earlier document but published on or after the international filing date *L* document which may throw doubts on priority claim(s) or which is cited to establish the publication date of another citation or other special reason (as specified) *O* document referring to an oral disclosure, use, exhibition or other means *P* document published prior to the international filing date but later than the priority date claimed </td> <td style="width: 50%; border: none; vertical-align: top;"> <ul style="list-style-type: none"> *T* later document published after the international filing date or priority date and not in conflict with the application but cited to understand the principle or theory underlying the invention *X* document of particular relevance; the claimed invention cannot be considered novel or cannot be considered to involve an inventive step when the document is taken alone *Y* document of particular relevance; the claimed invention cannot be considered to involve an inventive step when the document is combined with one or more other such documents, such combination being obvious to a person skilled in the art. *Z* document member of the same patent family </td> </tr> </table>			<ul style="list-style-type: none"> *A* document defining the general state of the art which is not considered to be of particular relevance *E* earlier document but published on or after the international filing date *L* document which may throw doubts on priority claim(s) or which is cited to establish the publication date of another citation or other special reason (as specified) *O* document referring to an oral disclosure, use, exhibition or other means *P* document published prior to the international filing date but later than the priority date claimed 	<ul style="list-style-type: none"> *T* later document published after the international filing date or priority date and not in conflict with the application but cited to understand the principle or theory underlying the invention *X* document of particular relevance; the claimed invention cannot be considered novel or cannot be considered to involve an inventive step when the document is taken alone *Y* document of particular relevance; the claimed invention cannot be considered to involve an inventive step when the document is combined with one or more other such documents, such combination being obvious to a person skilled in the art. *Z* document member of the same patent family
<ul style="list-style-type: none"> *A* document defining the general state of the art which is not considered to be of particular relevance *E* earlier document but published on or after the international filing date *L* document which may throw doubts on priority claim(s) or which is cited to establish the publication date of another citation or other special reason (as specified) *O* document referring to an oral disclosure, use, exhibition or other means *P* document published prior to the international filing date but later than the priority date claimed 	<ul style="list-style-type: none"> *T* later document published after the international filing date or priority date and not in conflict with the application but cited to understand the principle or theory underlying the invention *X* document of particular relevance; the claimed invention cannot be considered novel or cannot be considered to involve an inventive step when the document is taken alone *Y* document of particular relevance; the claimed invention cannot be considered to involve an inventive step when the document is combined with one or more other such documents, such combination being obvious to a person skilled in the art. *Z* document member of the same patent family 			
Date of the actual completion of the international search <p style="text-align: center; font-weight: bold;">22 September 2008</p>	Date of mailing of the international search report <p style="text-align: center; font-weight: bold;">08/10/2008</p>			
Name and mailing address of the ISA/ European Patent Office, P.B. 5818 Patentlaan 2 NL - 2280 HV Rijswijk Tel. (+31-70) 340-2040, Tx. 31 651 epo nl, Fax: (+31-70) 340-3016	Authorized officer <p style="text-align: center; font-weight: bold;">Bravin, Michel</p>			

INTERNATIONAL SEARCH REPORT

International application No

PCT/EP2008/056369

C(Continuation). DOCUMENTS CONSIDERED TO BE RELEVANT		
Category*	Citation of document, with indication, where appropriate, of the relevant passages	Relevant to claim No.
A	<p>EP 1 738 828 A (CANON KK [JP]) 3 January 2007 (2007-01-03) abstract paragraph [0016] paragraph [0031] paragraph [0048] - paragraph [0051]; figure 7</p>	1
A	<p>DE PRA M; KOK W TH; GARDENIERS J G E; DESMET G; EELTINK S; VAN NIEUWKASTEELE J W; SCHOENMAKERS P J: "Experimental Study on Band Dispersion in Channels Structured with Micropillars" ANALYTICAL CHEMISTRY, vol. 78, no. 18, 15 September 2006 (2006-09-15), pages 6519-6525, XP002496764 AMERICAN CHEMICAL SOCIETY abstract page 6525, column 1, line 5 - column 2, line 15 figure 1</p>	1
A	<p>US 6 156 273 A (REGNIER FRED E [US] ET AL) 5 December 2000 (2000-12-05) cited in the application abstract column 3, line 36 - column 4, line 25 column 8, line 10 - line 65 column 9, line 34 - line 42 column 10, line 41 - column 12, line 40 figures 1A-1D, 2E, 5A-5B, 6</p>	1, 12
A	<p>AJMERA S K ET AL: "Microfabricated cross-flow chemical reactor for catalyst testing" SENSORS AND ACTUATORS B, ELSEVIER SEQUOIA S.A., LAUSANNE, CH, vol. 82, no. 2-3, 28 February 2002 (2002-02-28), pages 297-306, XP004343663 ISSN: 0925-4005 abstract page 297, column 1, paragraph 1 - column 2, paragraph 2 page 298, column 1, paragraph 3 page 300, column 1, line 1 - line 3 page 300, column 1, paragraph 2 - column 2, last line page 302, column 1, last paragraph - column 2, line 3 page 305, column 2, paragraph 2 figures 2-4, 7, 8</p>	1, 9-12

-/--

INTERNATIONAL SEARCH REPORT

International application No

PCT/EP2008/056369

C(Continuation). DOCUMENTS CONSIDERED TO BE RELEVANT		
Category*	Citation of document, with indication, where appropriate, of the relevant passages	Relevant to claim No.
A	US 2005/095602 A1 (WEST JASON A [US] ET AL) 5 May 2005 (2005-05-05) abstract paragraphs [0070], [0077] figures 2,4,5 -----	1-4
A	US 2006/285996 A1 (OHMAN PER O [SE] ET AL) 21 December 2006 (2006-12-21) abstract paragraph [0057] paragraph [0061] paragraph [0073] figures 1,9 -----	1,5
A	EP 0 977 030 A (HEWLETT PACKARD CO [US]) 2 February 2000 (2000-02-02) abstract figure 1 -----	1,5-7
A	US 2006/065528 A1 (LOPEZ GABRIEL [US] ET AL) 30 March 2006 (2006-03-30) abstract paragraph [0008] paragraph [0091] - paragraph [0094] figures 6-9,11,13G -----	1,6-8,12
A	DE SMET J; GZIL P; VERVOORT N; VERELST H; BARON G V; DESMET G: "Influence of the Pillar Shape on the Band Broadening and the Separation Impedance of Perfectly Ordered 2-D Porous Chromatographic Media" ANALYTICAL CHEMISTRY, vol. 76, no. 13, 1 July 2004 (2004-07-01), pages 3716-3726, XP002496765 AMERICAN CHEMICAL SOCIETY abstract page 3720, column 1, paragraph 2 - page 3721, column 1, paragraph 3 figure 1 -----	1

INTERNATIONAL SEARCH REPORT

Information on patent family members

International application No

PCT/EP2008/056369

Patent document cited in search report	Publication date	Patent family member(s)	Publication date	
EP 1738828	A	03-01-2007	CN 1892220 A	10-01-2007
			US 2007004029 A1	04-01-2007
US 6156273	A	05-12-2000	DE 69829181 D1	07-04-2005
			DE 69829181 T2	29-12-2005
			EP 0985146 A1	15-03-2000
			WO 9854568 A1	03-12-1998
			US 6596144 B1	22-07-2003
US 2005095602	A1	05-05-2005	NONE	
US 2006285996	A1	21-12-2006	AU 2006259886 A1	28-12-2006
			CN 101203311 A	18-06-2008
			EP 1893337 A1	05-03-2008
			SE 528233 C2	26-09-2006
			SE 0501418 A	26-09-2006
WO 2006137785 A1	28-12-2006			
EP 0977030	A	02-02-2000	DE 69800630 D1	26-04-2001
			DE 69800630 T2	23-08-2001
			US 6254754 B1	03-07-2001
US 2006065528	A1	30-03-2006	NONE	