



(22) Date de dépôt/Filing Date: 2007/07/06
(41) Mise à la disp. pub./Open to Public Insp.: 2008/01/11
(30) Priorité/Priority: 2006/07/11 (US11/484,274)

(51) Cl.Int./Int.Cl. *B63B 35/78* (2006.01),
B63B 35/73 (2006.01), *B63H 21/17* (2006.01),
B63H 5/08 (2006.01)

(71) Demandeur/Applicant:
TWIN TROLLER BOATS, INC., US

(72) Inventeurs/Inventors:
JONES, FRANK W., US;
LEE, WARREN D., US

(74) Agent: MCFADDEN, FINCHAM

(54) Titre : BATEAU DE PLAISANCE EQUIPE DE PROPULSEURS ELECTRIQUES JUMELES
(54) Title: RECREATIONAL BOAT HAVING TWIN ELECTRIC TROLLING MOTORS

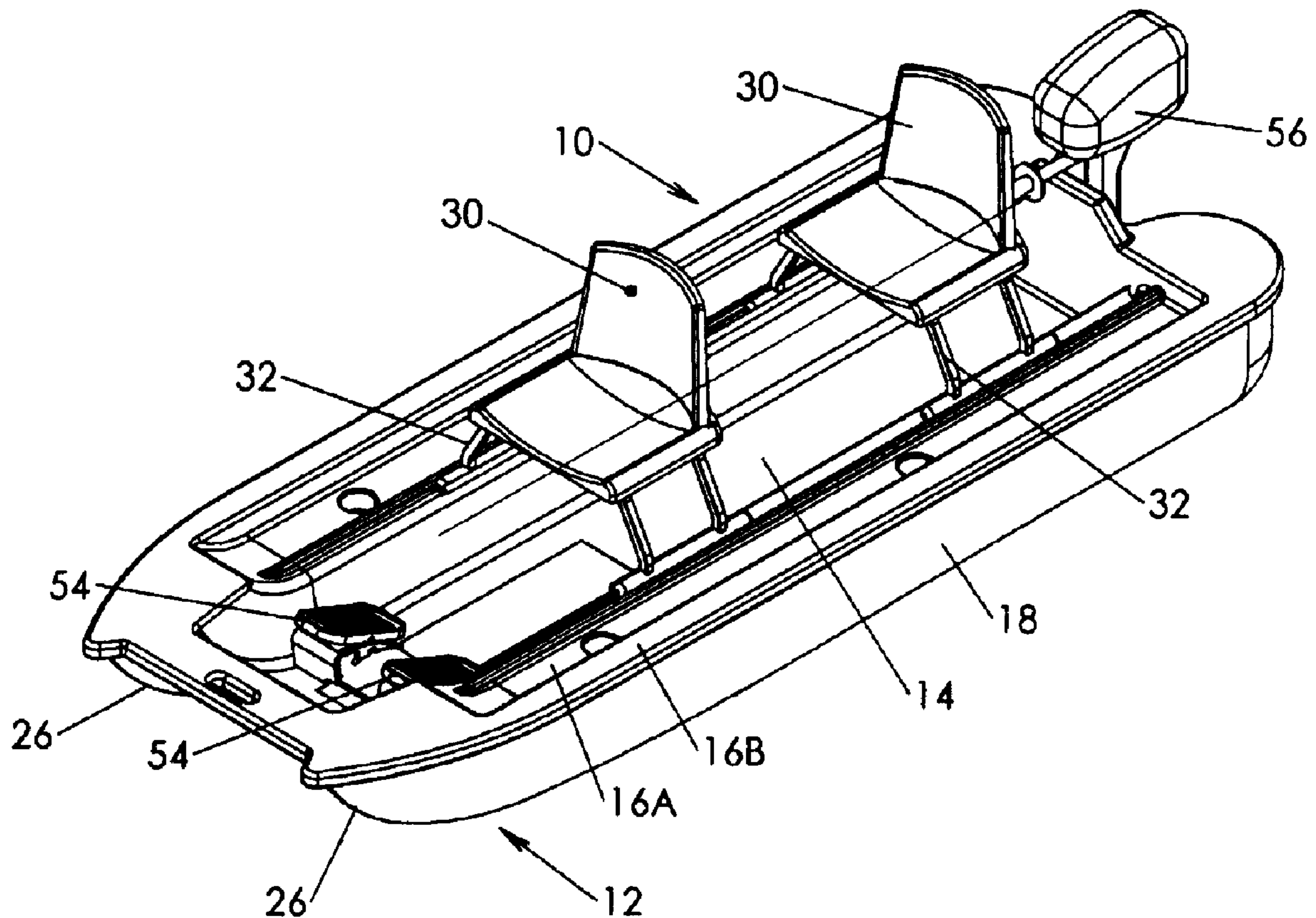

(57) Abrégé/Abstract:

A recreational boat comprising a boat hull having a bottom and a top deck. Formed in the bottom are two spaced apart elongated cavities that extend substantially the entire length of the boat. Disposed in each cavity intermediately between the front and rear of

(57) **Abrégé(suite)/Abstract(continued):**

the boat is an electric trolling motor. Each electric trolling motor is independently controlled by a foot pedal mounted on the top deck. Hence, the boat is propelled by the trolling motor and can be steered by independently controlling each of the electric trolling motors.

ABSTRACT

A recreational boat comprising a boat hull having a bottom and a top deck. Formed in the bottom are two spaced apart elongated cavities that extend substantially the entire length of the boat. Disposed in each cavity intermediately between the front and rear of the boat is an electric trolling motor. Each electric trolling motor is independently controlled by a foot pedal mounted on the top deck. Hence, the boat is propelled by the trolling motor and can be steered by independently controlling each of the electric trolling motors.

RECREATIONAL BOAT HAVING TWIN ELECTRIC TROLLING MOTORS

[0001] The present invention relates to small watercrafts, and more particularly to watercrafts that are powered, in part at least, by electric trolling motors.

BACKGROUND OF THE INVENTION

[0002] Small boats that employ electric trolling motors are known and are typically used on lakes and ponds for recreation and fishing. They are popular for a number of reasons. They are relatively small, lightweight, easy to handle and maneuver and can be enjoyed by adults and children alike.

[0003] However, many trolling motor boats of this type do not integrate the trolling motors into the hull of the boat. Instead, trolling motors are attached to an exterior portion of the boat and because of that the trolling motors appear to be, and often are, add-ons. This means that the trolling motors may hang from the side of the boat and impair the boat's ability to be maneuvered through close quarters. Further, if the boat is transported from one lake to another, the trolling motors may have to be removed and replaced. In addition, security may be an issue if the boat with the trolling motors mounted thereon is left unattended.

[0004] Therefore, there has been and continues to be a need for a small, recreational boat that utilizes electric trolling motors where the trolling motors are integrated into the hull of the boat.

SUMMARY

[0005] The present invention relates to a small boat or watercraft that is powered by two electric trolling motors integrated into the hull of the boat.

[0006] In one particular embodiment of the present invention, the boat hull is provided with a pair of spaced apart elongated cavities that are formed in the bottom of the boat hull. Disposed in each of these cavities is an electric trolling motor that is controlled from an upper deck area of the boat.

[0007] Other objects and advantages of the present invention will become apparent and obvious from a study of the following description and the accompanying drawings which are merely illustrative of such invention.

BRIEF DESCRIPTION OF THE DRAWINGS

[0008] Figure 1 is a perspective view of the trolling boat of the present invention.

[0009] Figure 2 is a top plan view of the boat.

[0010] Figure 3 is a cross sectional view of the boat taken along the line 3-3 of Figure 2.

[0011] Figure 4 is a front elevational view of the boat.

DESCRIPTION OF EXEMPLARY EMBODIMENT

[0012] With further reference to the drawings, the trolling boat of the present invention is shown therein and indicated generally by the numeral 10. As will be appreciated from subsequent portions of this disclosure, trolling boat 10 is a relatively small and highly maneuverable water craft that is particularly useful as a recreational

boat on ponds and lakes. Viewing trolling boat 10 in more detail, the trolling boat 10 includes a hull indicated generally by the numeral 12. The hull 12 includes a top, bottom, sides and front and rear areas. While the hull 12 can be manufactured from various materials utilizing various processes, it is contemplated that in one embodiment, the hull 12 would be constructed of high density polyethylene through a rotational molding or vacuum molding process.

[0013] Viewing hull 12 in more detail, it is seen that the same includes a top deck. The top deck includes multi levels. As seen in the drawings, forming a part of the top deck is a central sunken section or portion 14. This section of the top deck extends substantially the length of the hull 12. Stepped up from the central sunken section 14 is an outer raised portion. In the particular embodiment disclosed herein, the outer raised portion includes an outer perimeter portion 16B that extends around the hull 12. Just inwardly of the outer raised portion 16B is an area designated by 16A. Area 16A is stepped up from the central sunken portion 14 but is disposed just below the level of outer portion 16B.

[0014] Hull 12 includes a pair of opposed side walls 18 and a bottom indicated generally by the numeral 20. See Figure 3. Bottom 20 includes a central portion 20A. Formed in the bottom 20 is a pair of spaced apart cavities 22. Cavities 22 are formed by a cavity wall 24 that forms a part of the bottom 20 of the hull 12. As seen in Figure 3, the two cavities 22 are spaced apart and disposed just outwardly of the central bottom portion 20A. Each cavity 22 is elongated and extends a substantial length along the hull 12. Each cavity 22 is open at the bottom and back, but is generally closed at the front. As noted in Figure 3, each cavity 22 and its surrounding wall structure 24 assumes a

generally inverted U shape with the top portion of the cavity 22 being generally curved or cylindrically shaped. Cavity 22 may assume other forms or configurations. For example, the front of the cavity 22 could be open. In a configuration where the front of the cavity 22 is open, the bottom of the cavity 22 could be closed so as to define an elongated front-to-back opening in the hull and through which water would pass as the boat is propelled through the water.

[0015] As noted above, the front portions of each cavity 22 is generally closed. As seen in Figure 1, the front or bow portion of the boat 10 includes a pair of keels 26. Keels 26 form a point and function to cut through the water as the trolling boat 10 is propelled, generally preventing splashing. Each keel 26 is generally aligned with a respective cavity 22. In one embodiment or design, the front of the cavity 22 is closed and because of the structure of the hull, and how the front portions of the cavities 22 are closed, the hull structure is overlapped at the keels 26. This feature imparts strength and rigidity to the keels 26.

[0016] Mounted on the top deck of the boat 10 is one or more seats 30. Each seat 30 includes a seat frame 36 that transversely spans the central sunken section 14 of the hull 12. In the case of the present embodiment, the seat frame 32 includes a pair of curved arms that extend from each side of the seat 30 and attach to a runner that is retained within a longitudinal groove or slot formed in a portion of the top deck of the boat. Preferably the one or more seats 30 can be adjusted fore and aftly along the top deck. Seat 30 and seat frame 32 would be provided with a releasable locking mechanism that would permit the seat frame 32 to be adjusted to a particular position with respect to the top deck of the boat.

[0017] Mounted in each cavity 22 is an electric trolling motor indicated generally by the numeral 50. This is particularly illustrated in Figure 3. Details of the electric trolling motors 50 are not dealt with herein because such is not per se material to the present invention, and further electric trolling motors are well known in the art. In any event, each electric trolling motor 50 includes an electric motor and a propeller, both of which are disposed in a respective cavity 22. To support the trolling motors 50 within the cavities 22, each trolling motor 50 is provided with a support shaft 52 that suspends the trolling motor 50 at an appropriate elevation within a respective cavity 22. More particularly, the support shaft 52 supports the electric motor and propeller of each trolling motor 50 in a fixed location within one of the cavities 22. The electric motor and propeller that form each trolling motor 50 is longitudinally aligned with a cavity 22. As seen in Figure 3, the wall 24 of the cavity 22 substantially encompasses and extends around each trolling motor 50. Although the bottom of the cavity 22 is open, in the embodiment illustrated in Figure 3, the wall 24 of the cavity 22 surrounds the opposed sides and top of the trolling motor 50 mounted therein. Because the trolling motors 50 are powered by battery, there are provisions for directing wiring from the controls through the hull to each of the trolling motors 50. Also, the motors 50 are mounted intermediately in the cavities 22 such that water can enter from the front and back of the motors 50. When the motors 50 are operating in a "forward" direction, water will enter from the front of the motor, and when the motors 50 are operating in "reverse," water will enter from the rear of the motors 50.

[0018] As noted above, the trolling motors 50 disclosed in this embodiment are electric trolling motors. Hence, they are powered by a battery (not shown). In order to

control both the propulsion and steering of the boat 10, there is provided a pair of foot pedals 54. Foot pedals 54 are disposed on the central sunken portion 14 of the top deck and would be adjustable both laterally and longitudinally. Each pedal would control one of the electric trolling motors 50. There would be both a forward and reverse control, and the foot pedals 54 would provide variable speed control in both forward and reverse directions. Details of the controls are not dealt with herein because such is not per se material to the present invention and such controls are known in the art. For a more unified and complete understanding of one type of control system for a small electric trolling motor boat, one is referred to the disclosure found in U.S. Patent No. 5,131,875, which is expressly incorporated herein by reference.

[0019] As an option, the boat 10 of the present invention is provided about the stern with a mount for receiving and supporting a gasoline engine denoted by the numeral 56. Preferably, the mount for mounting the optional gasoline engine 56 is integrated into the hull 12. In certain cases, it might be desirable to mount a gasoline engine to the boat in order to provide additional power and speed.

[0020] As appreciated from the foregoing discussion, it is seen that the trolling boat 10 of the present invention is of a simple and compact design that is highly maneuverable. By strategically placing the electric trolling motors 50 inboard the sides 18 and in the cavities 22, the boat becomes sleek and streamlined with its twin trolling motors 50 basically confined interiorly of the exterior portions of the hull 12. This enables the boat 10 to be easily transported and handled, and eliminates the need to disconnect and connect trolling motors each time the boat is transported from one lake or pond to another.

[0021] The present invention may, of course, be carried out in other specific ways than those herein set forth without departing from the scope and the essential characteristics of the invention. The present embodiments are therefore to be construed in all aspects as illustrative and not restrictive and all changes coming within the meaning and equivalency range of the appended claims are intended to be embraced therein.

CLAIMS

What is claimed is:

1. A recreational trolling boat, comprising:
 - a. a molded hull having opposed sides, front, rear and bottom;
 - b. a pair of spaced apart elongated cavities formed in the bottom of the hull with each cavity being spaced inwardly from an adjacent side of the hull and open from the bottom;
 - c. an electric trolling motor mounted in each cavity intermediately between the front and rear of the hull; and
 - d. wherein each electric trolling motor is independently controlled to propel and steer the boat.
2. The recreational trolling boat of claim 1 wherein each cavity includes a generally inverted U-shaped wall.
3. The recreational trolling boat of claim 1 wherein each electric trolling motor includes a motor and a propeller and wherein each cavity extends substantially around the motor and propeller of each trolling motor.
4. The recreational trolling boat of claim 1 wherein each cavity includes a front portion and a rear portion and wherein the front portion of each cavity is generally closed and the rear portion of each cavity is generally open.
5. The recreational trolling boat of claim 1 wherein the hull includes a top deck that includes a central sunken portion that lies at a level below a top portion of the cavities.

6. The recreational trolling boat of claim 5 wherein the central sunken portion of the top deck extends generally between the two cavities.
7. The recreational trolling boat of claim 1 wherein the hull includes a top deck and wherein portions of the top deck are spaced above the cavities so as to define an open area between the cavities and portions of the top deck.
8. The recreational trolling boat of claim 1 wherein each cavity includes a surrounding wall and wherein each trolling motor includes a support shaft that extends through the wall of the adjacent cavity.
9. The recreational trolling boat of claim 1 wherein the hull includes a top deck having a central sunken portion and an outer raised portion disposed on each side of the central sunken portion; and wherein the central sunken portion is disposed at a level below a top portion of the respective cavities such that the central sunken portion of the top deck extends generally between the cavities.
10. The recreational trolling boat of claim 9 wherein the boat includes one or more seats, with each seat having a frame structure that spans the central sunken portion of the top deck and is supported by the outer raised portion of the top deck.
11. The recreational trolling boat of claim 10 including a pair of foot controls disposed on the central sunken portion of the top deck with each foot control being operative to control one of the trolling motors.
12. The recreational trolling boat of claim 1 including a gasoline engine mounted to the rear of the boat.

13. The recreational trolling boat of claim 9 wherein the outer raised portion includes a pair of rear areas that project from the boat and which are at least slightly curved.

14. The recreational trolling boat of claim 1 wherein each side of the hull includes a side wall that extends downwardly and curves generally inwardly, and thereafter joins a portion of a respective cavity.

15. The recreational trolling boat of claim 14 wherein there is defined an open space between each side wall of the hull and a substantial portion of a wall that forms a part of an adjacent cavity.

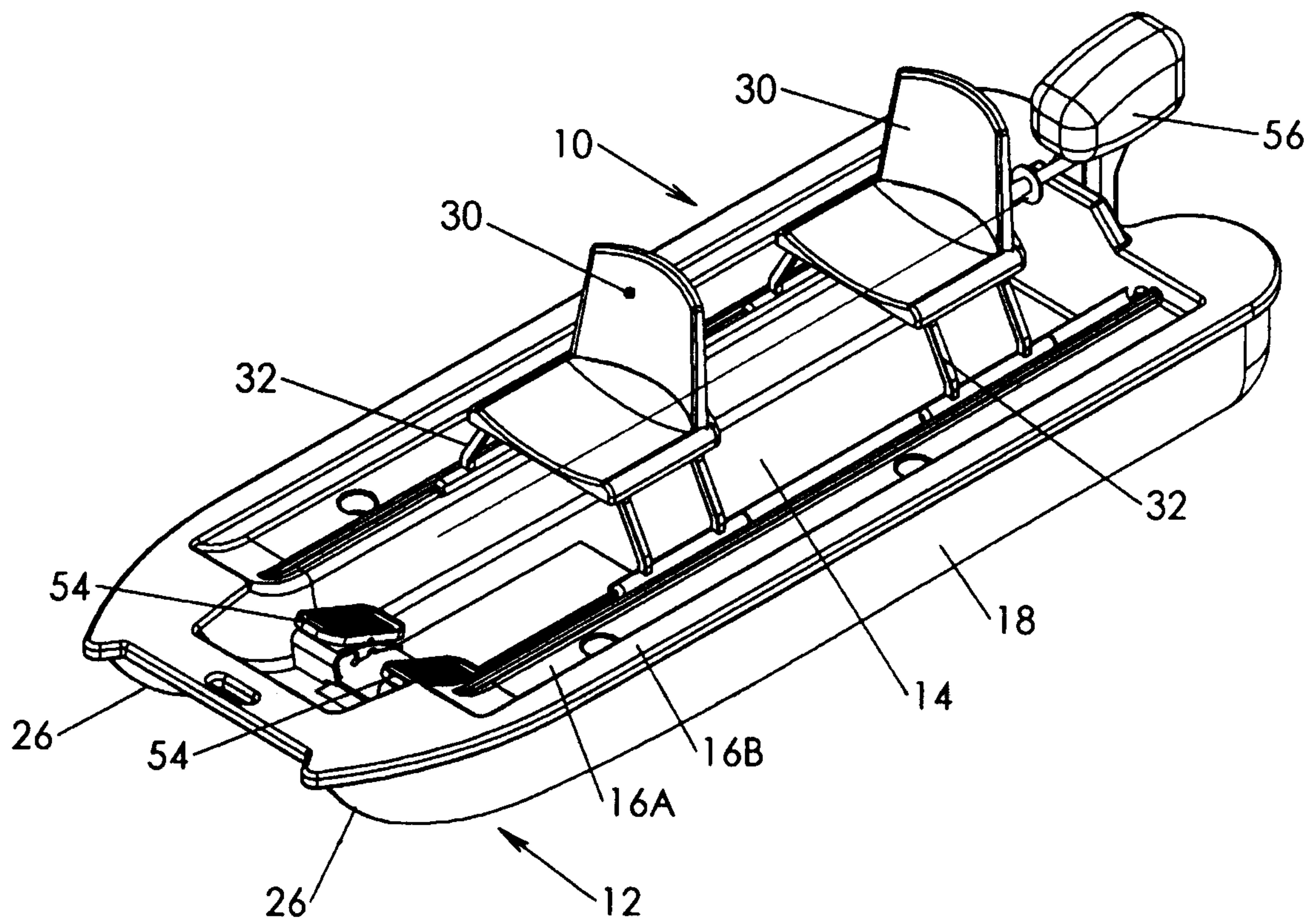

Fig. 1

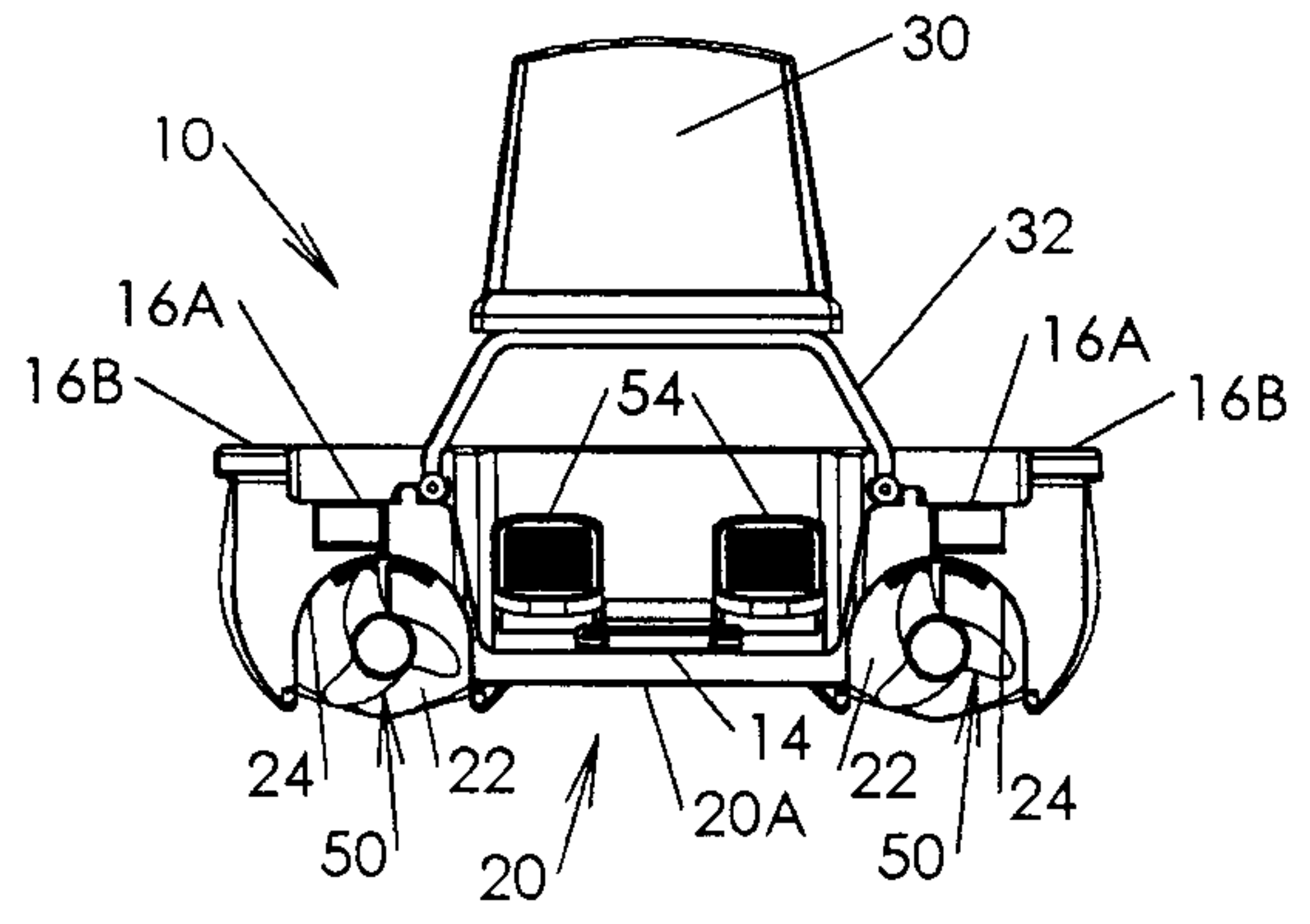

Fig. 3

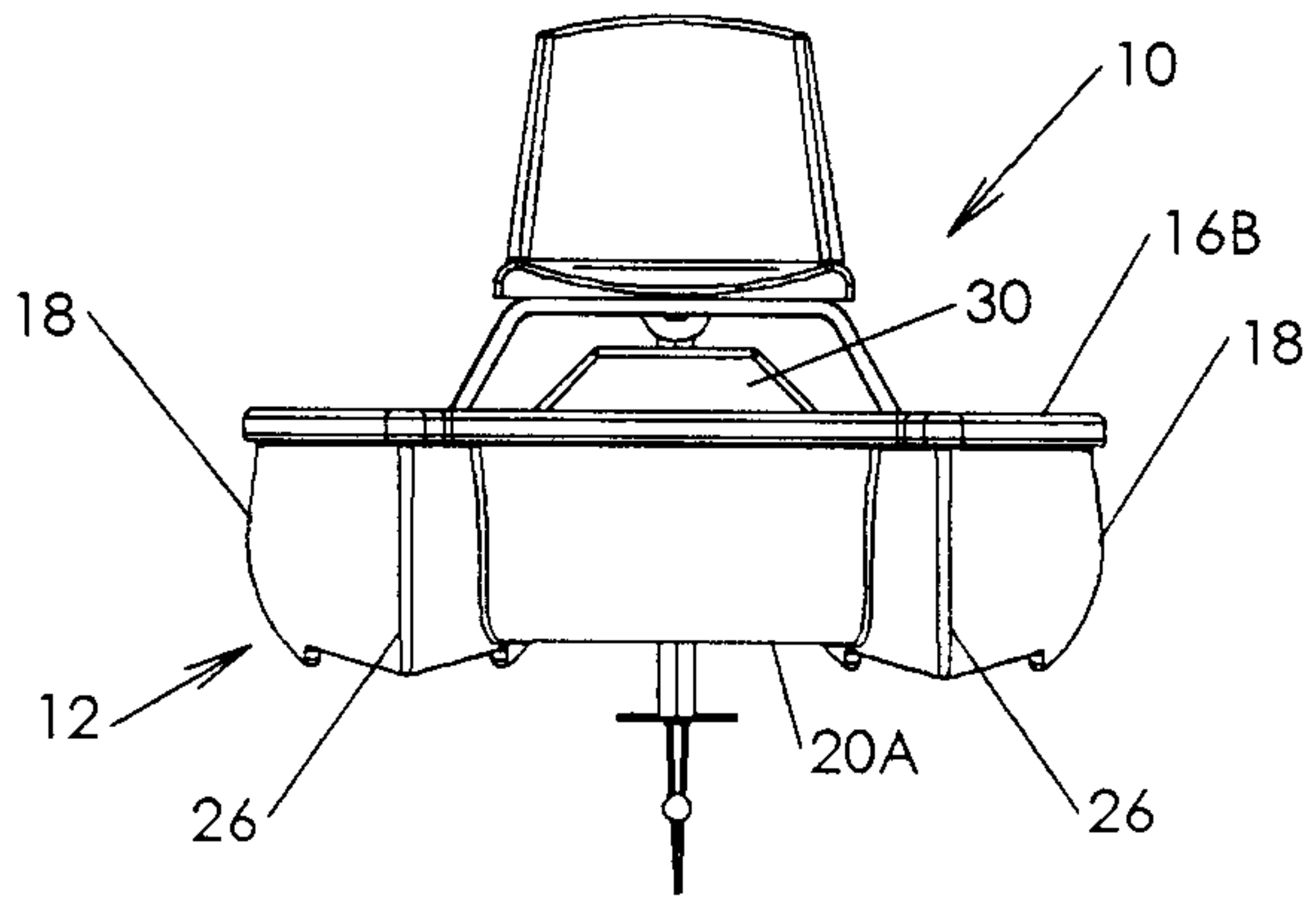

Fig. 4

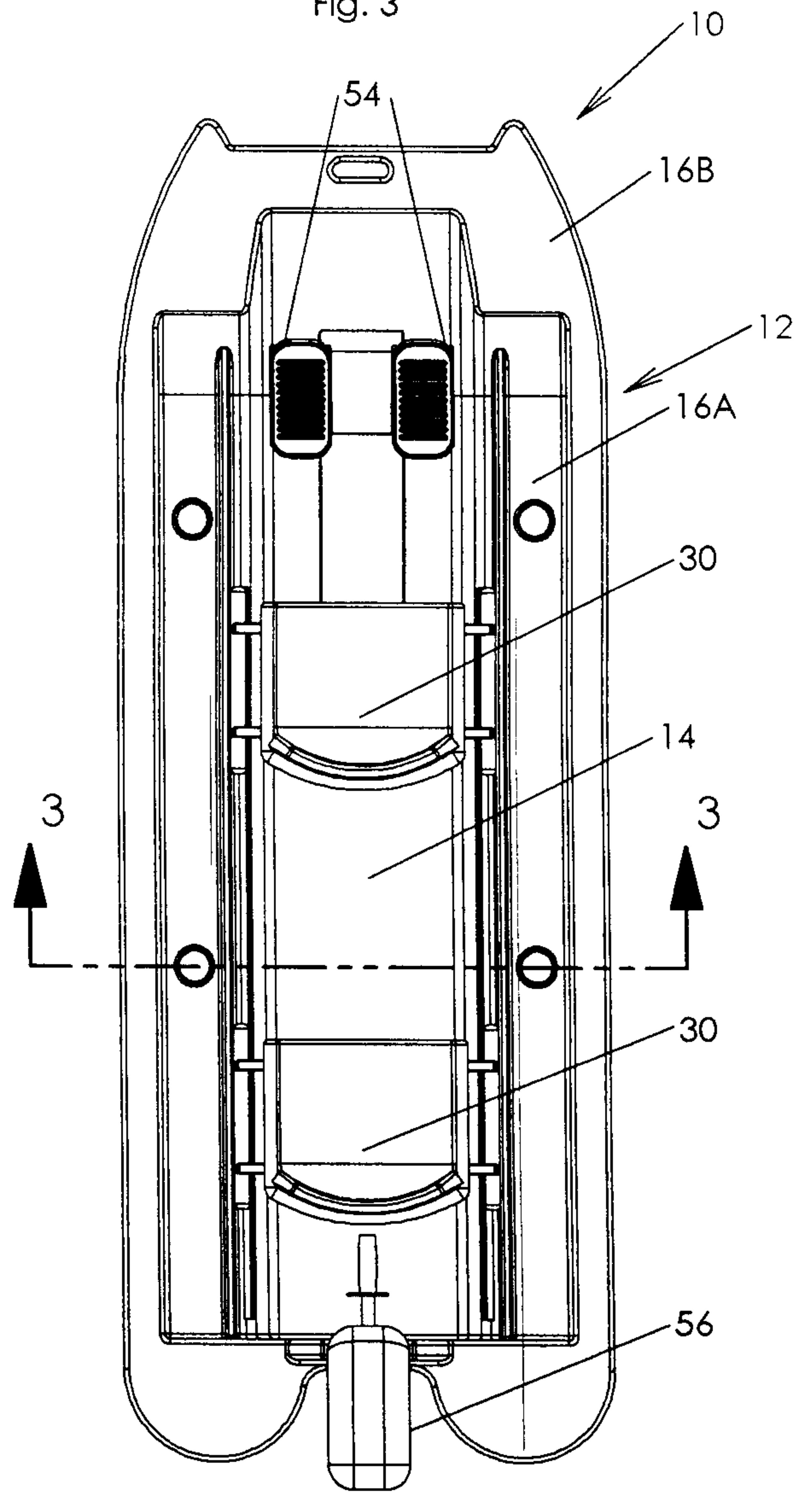

Fig. 2

