



US 20120288174A1

(19) **United States**

(12) **Patent Application Publication**
Dale et al.

(10) **Pub. No.: US 2012/0288174 A1**

(43) **Pub. Date: Nov. 15, 2012**

(54) **ATLAS AND METHODS FOR SEGMENTATION AND ALIGNMENT OF ANATOMICAL DATA**

Publication Classification

(51) **Int. Cl.**
G06K 9/00 (2006.01)

(75) **Inventors:** **Anders Dale**, La Jolla, CA (US);
Sebastian Gicquel, Merignac (FR)

(52) **U.S. Cl.** **382/131**

(73) **Assignee:** **CORTECHS LABS, INC.**, La Jolla, CA (US)

(57) **ABSTRACT**

(21) **Appl. No.:** **13/411,041**

(22) **Filed:** **Mar. 2, 2012**

The present invention provides an atlas comprising values representative of magnetic resonance properties of a magnetic resonance (MR) scan and optionally, prior probability data relating to tissue type. Further embodiments of the invention involve a system including an MR scanner and the atlas for use in alignment of an MR scan, such as a localizer scan, to obtain a specific geometry of the data acquired during a subsequent scan. Also, a system includes an MR scanner and the atlas for automatic segmentation of an MR scan. Methods of making and using the atlas and system are also provided.

Related U.S. Application Data

(63) Continuation of application No. 11/999,887, filed on Dec. 7, 2007, now Pat. No. 8,140,144, which is a continuation of application No. 10/055,256, filed on Jan. 22, 2002, now Pat. No. 7,324,842.

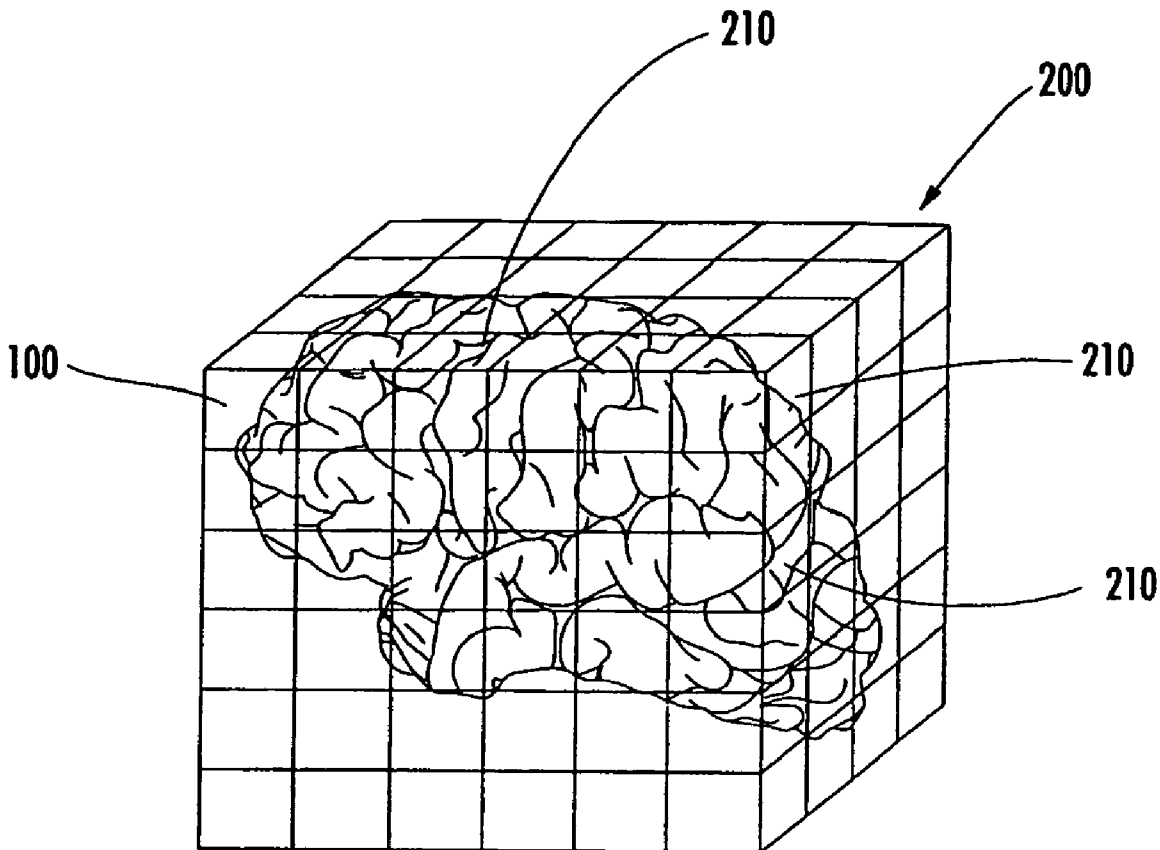

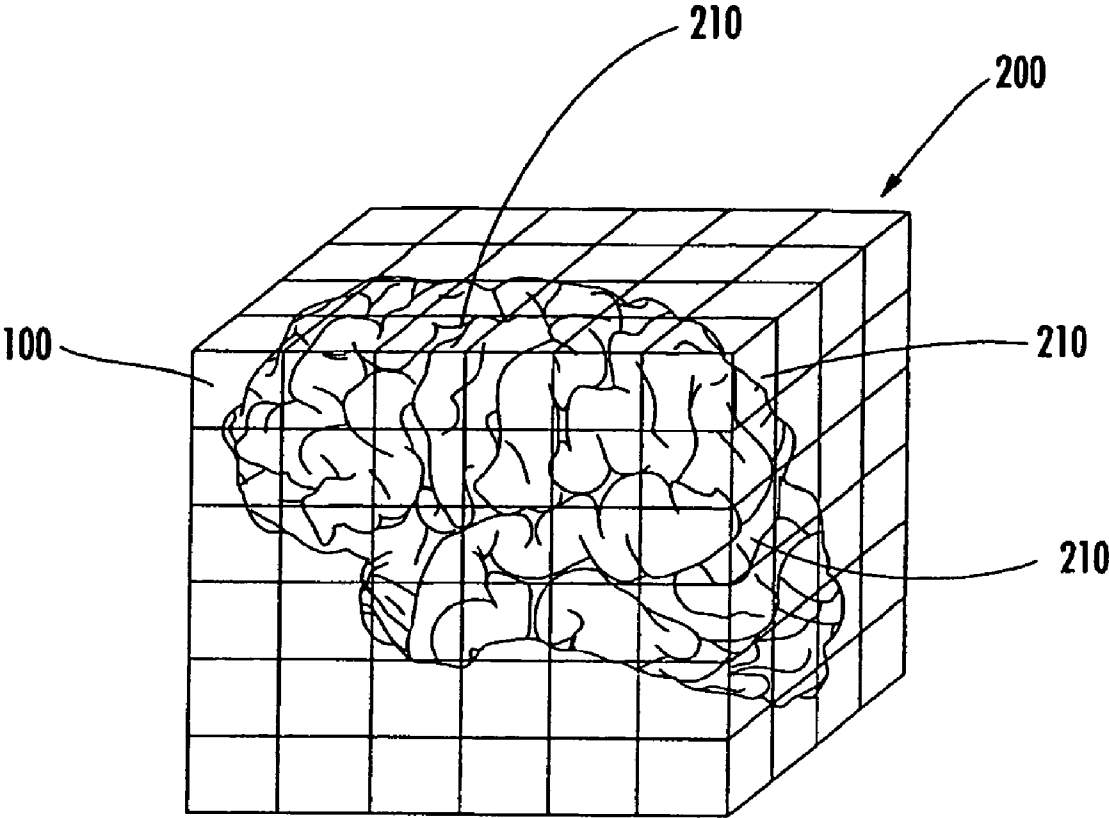

FIGURE 1

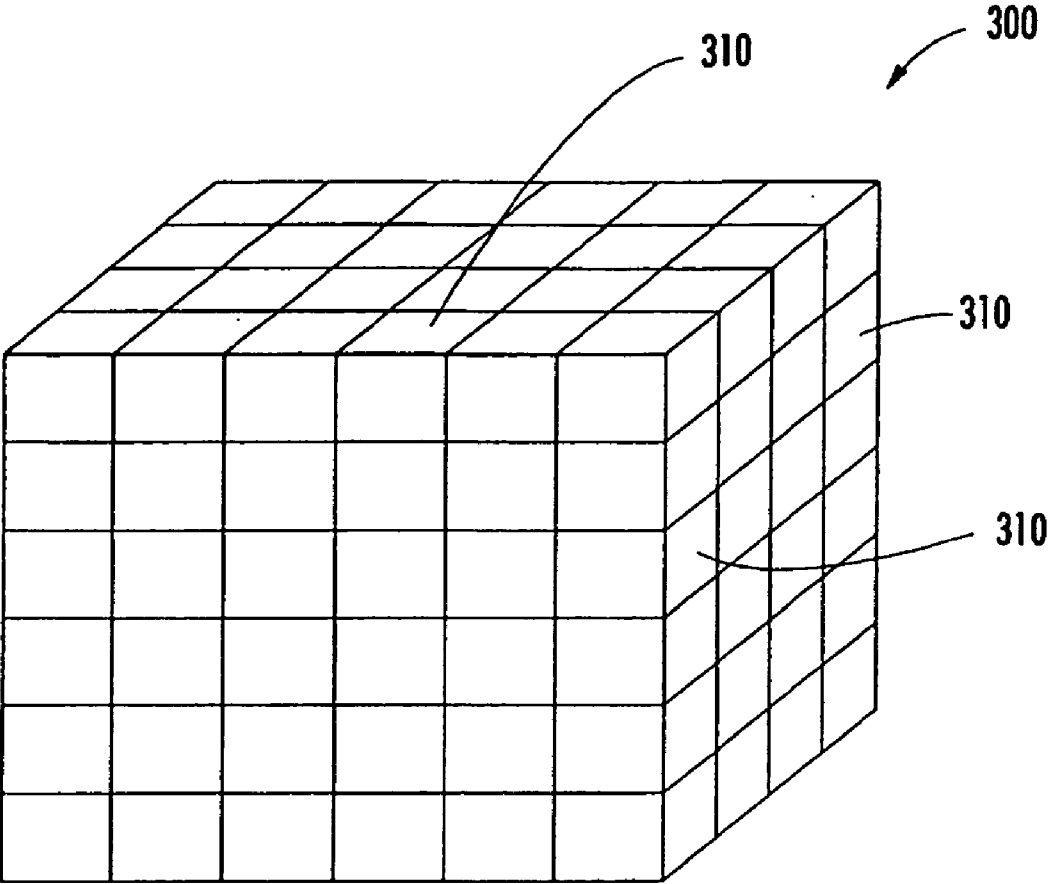

FIGURE 2

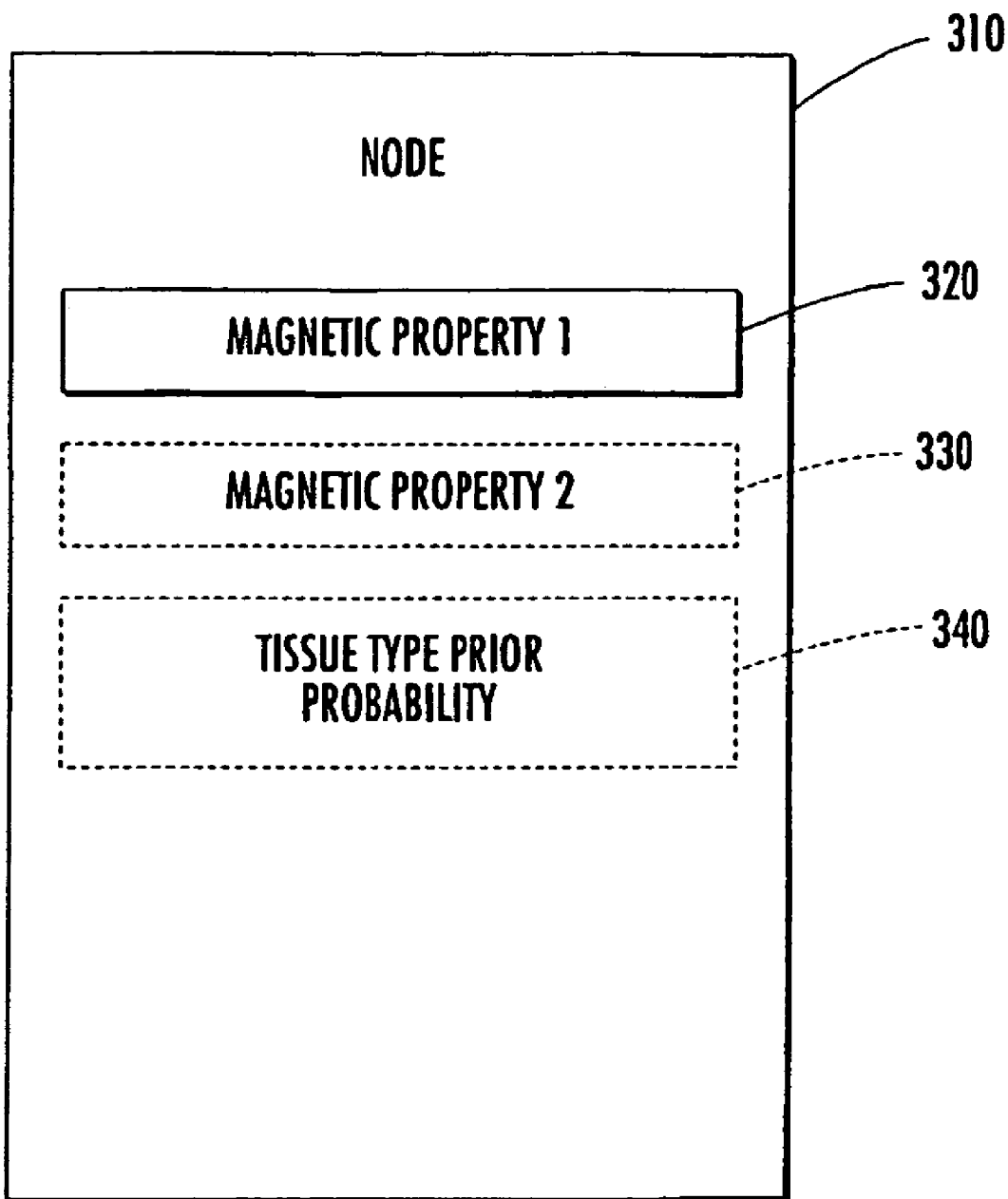

FIGURE 3

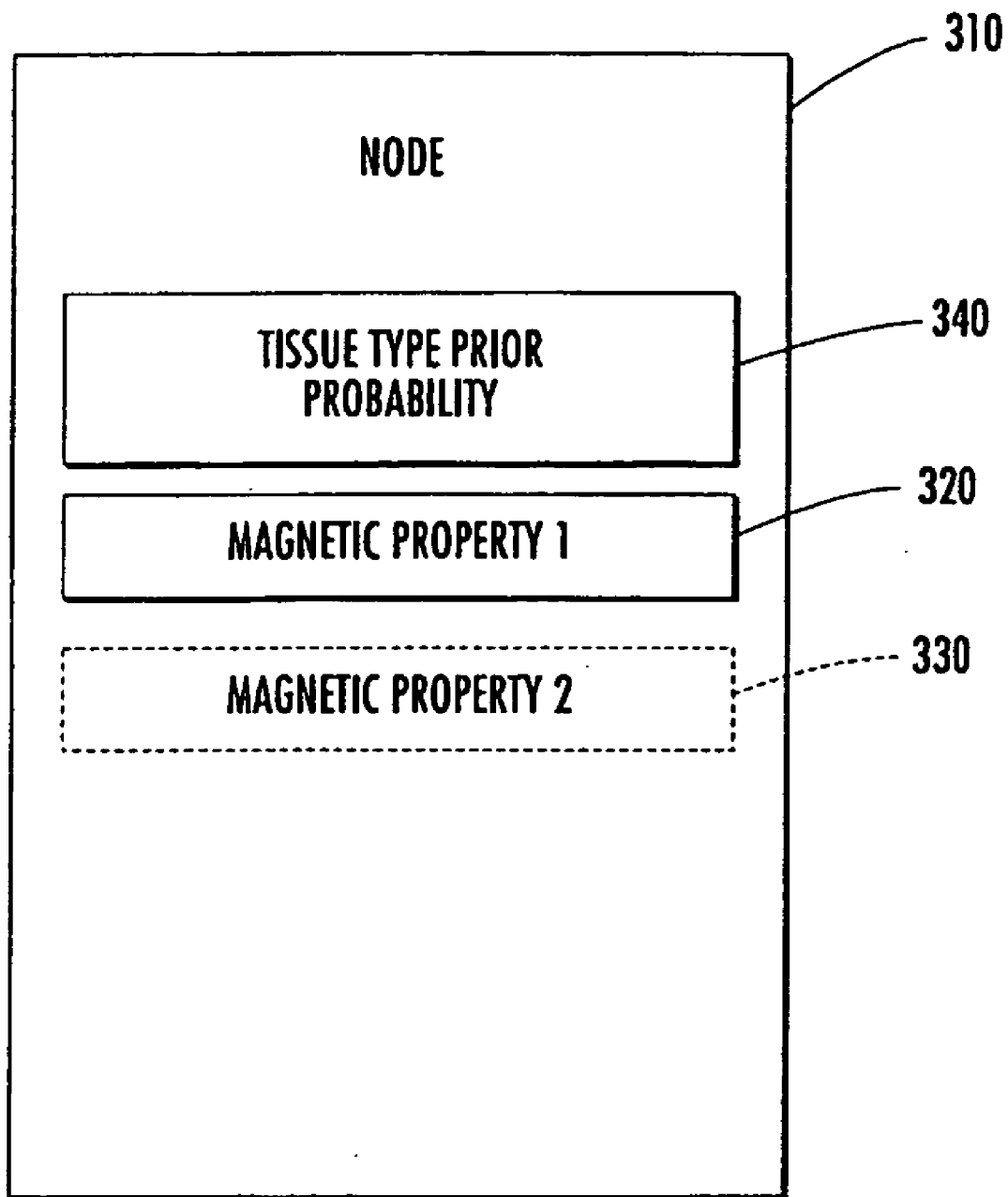

FIGURE 4

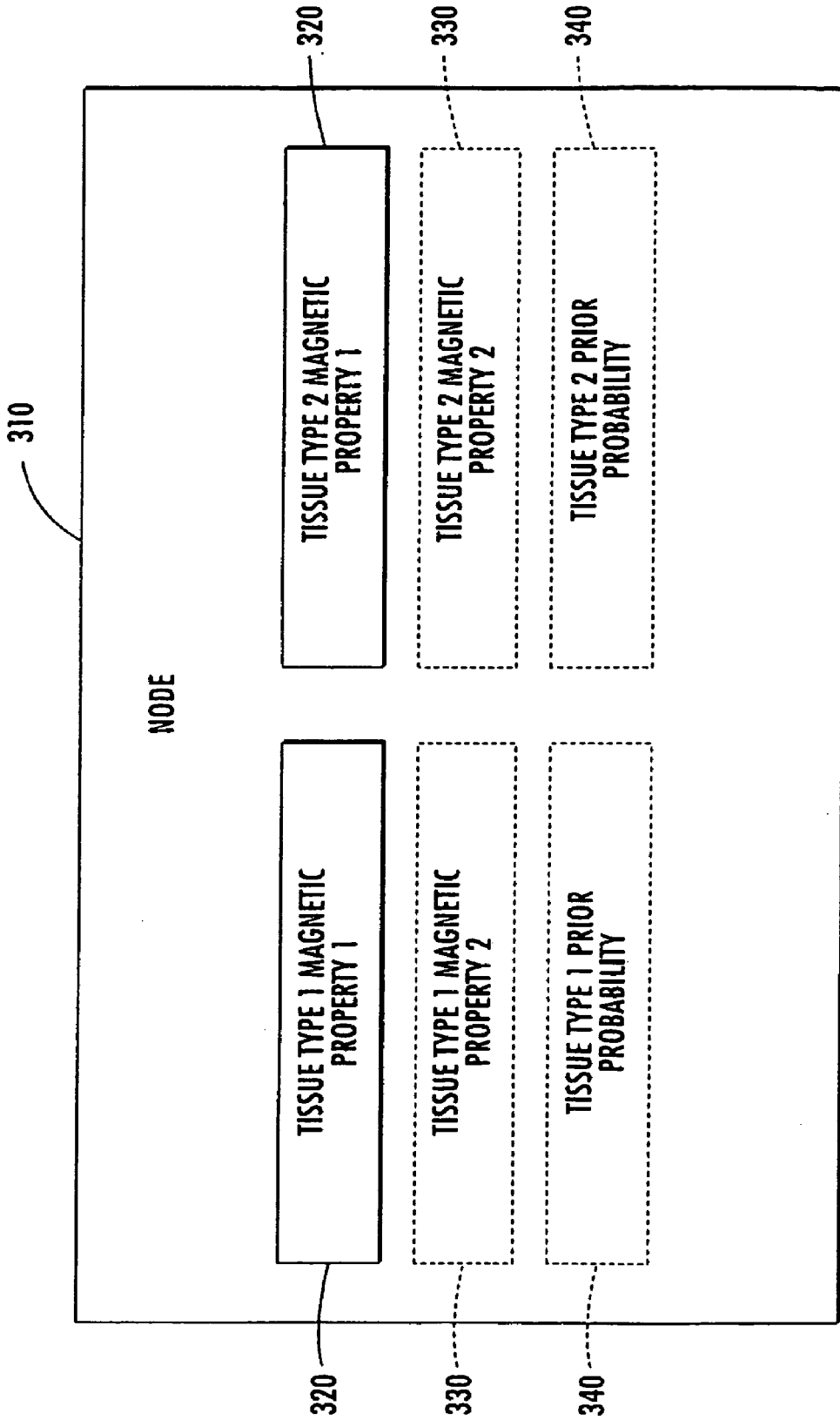

FIGURE 5

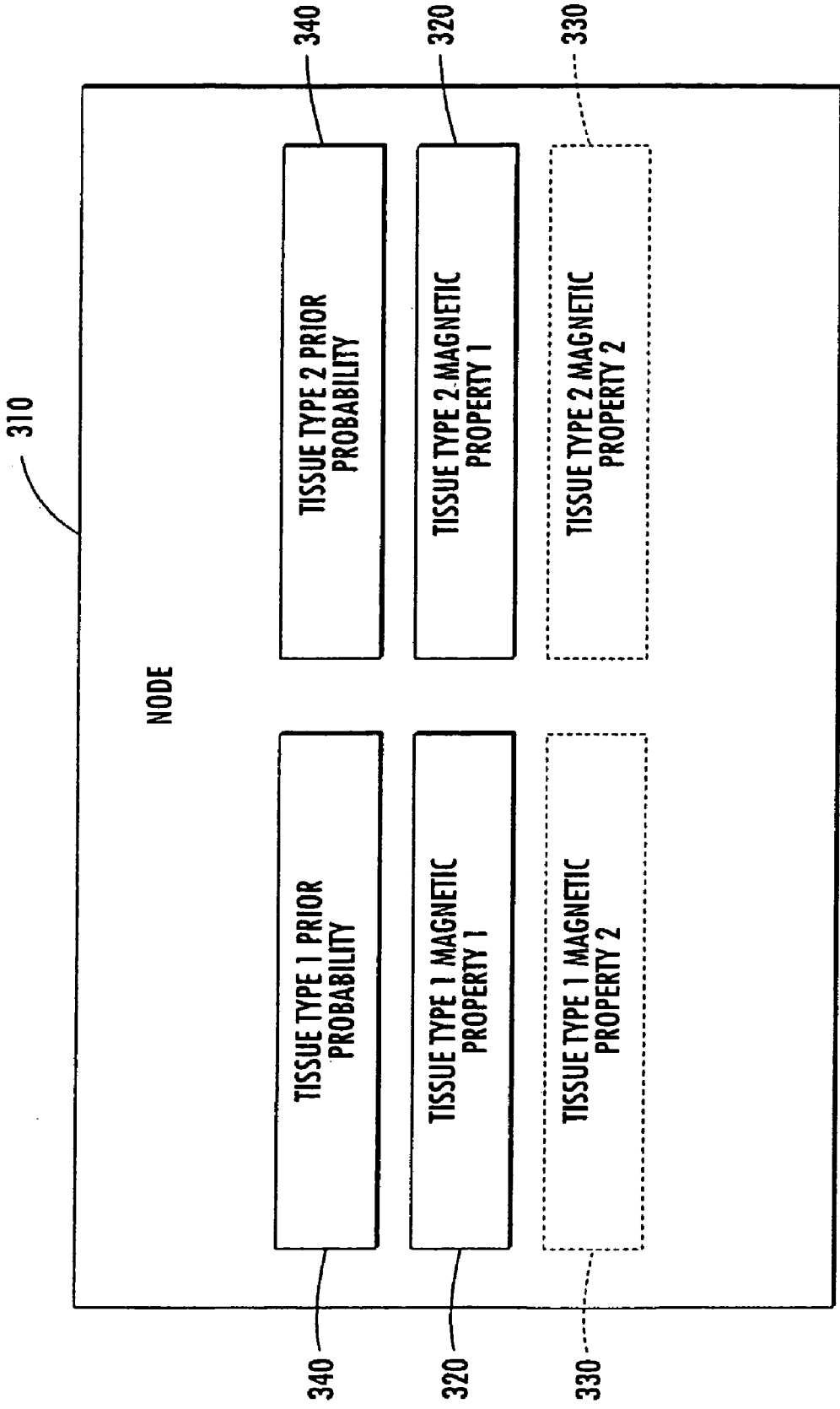

FIGURE 6

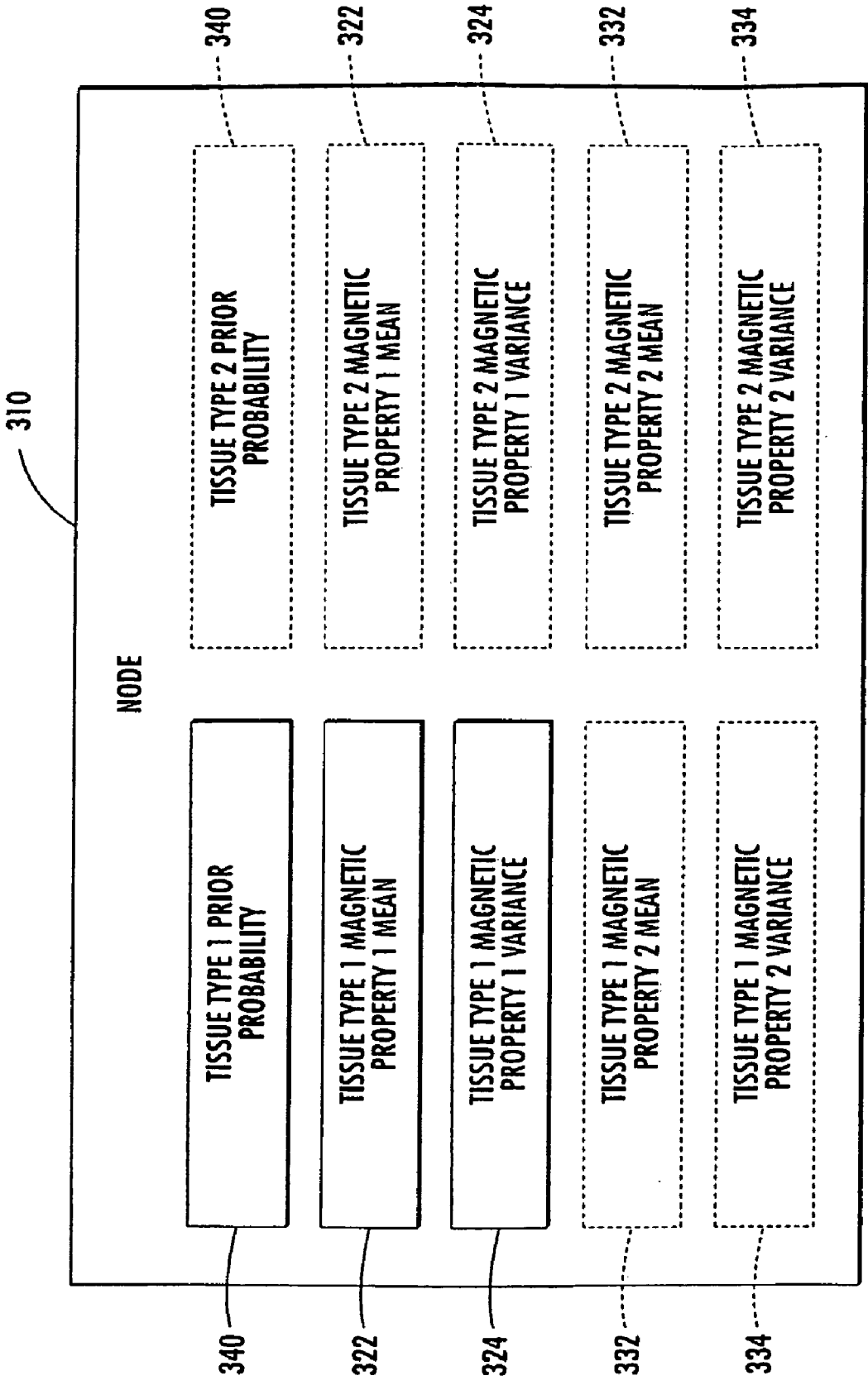

FIGURE 7

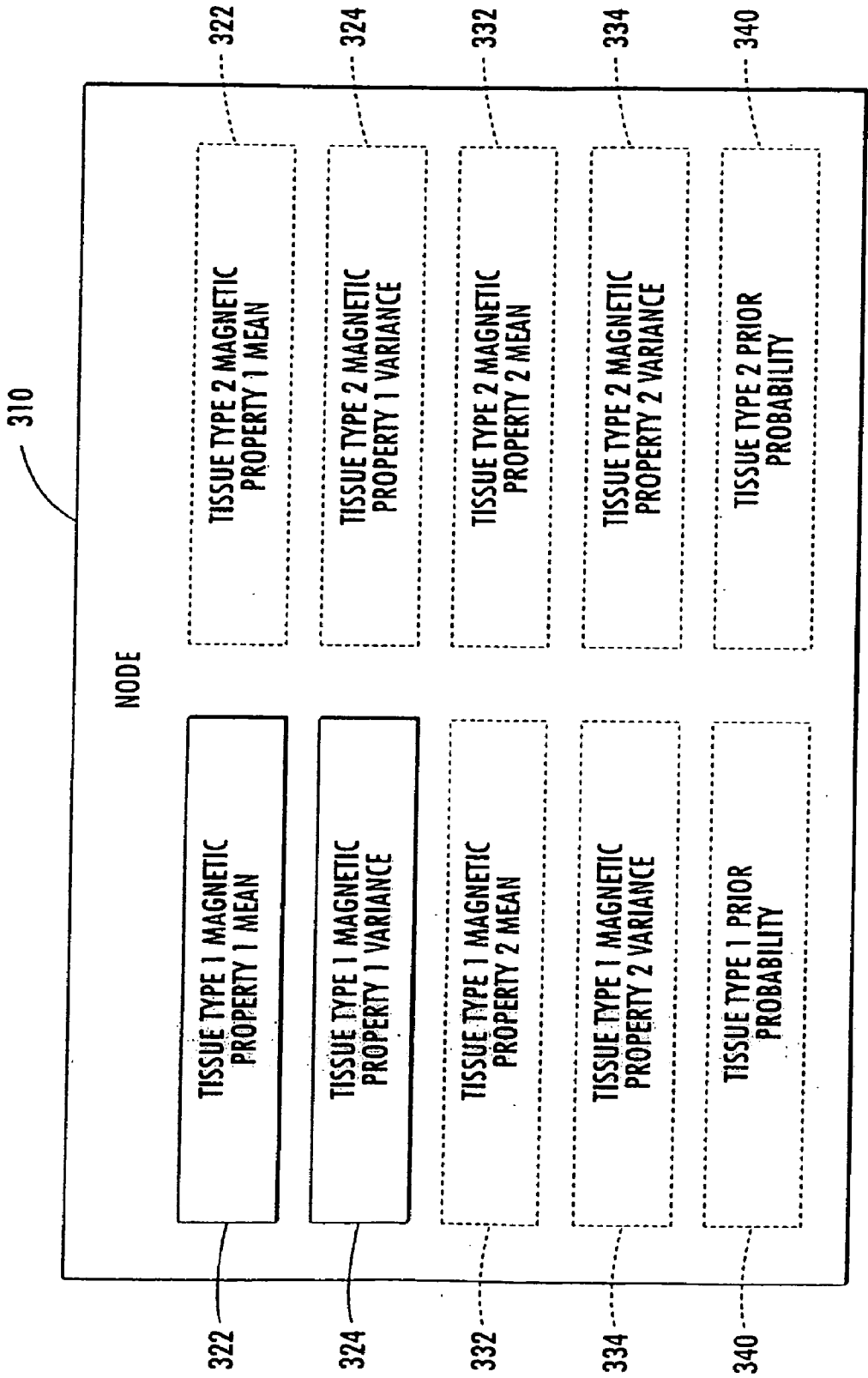

FIGURE 8

400

| | | | |
|--------------------|-----|-----|----|
| SUBJECT | 1 | 2 | 3 |
| INTENSITY | 100 | 200 | 50 |
| TISSUE TYPE | 1 | 1 | 2 |

FIGURE 9A

410 420 430

| | | | | |
|--------------------|---------------|---------------|---------------|-----|
| STEP | STEP 1 | STEP 2 | STEP 3 | |
| TISSUE TYPE | 1 | 1 | 1 | 2 |
| MEAN | 100 | 150 | 150 | 50 |
| VARIANCE | 0 | 50 | 50 | 0 |
| PROBABILITY | 1 | 1 | 2/3 | 1/3 |

322 →

324 →

FIGURE 9B

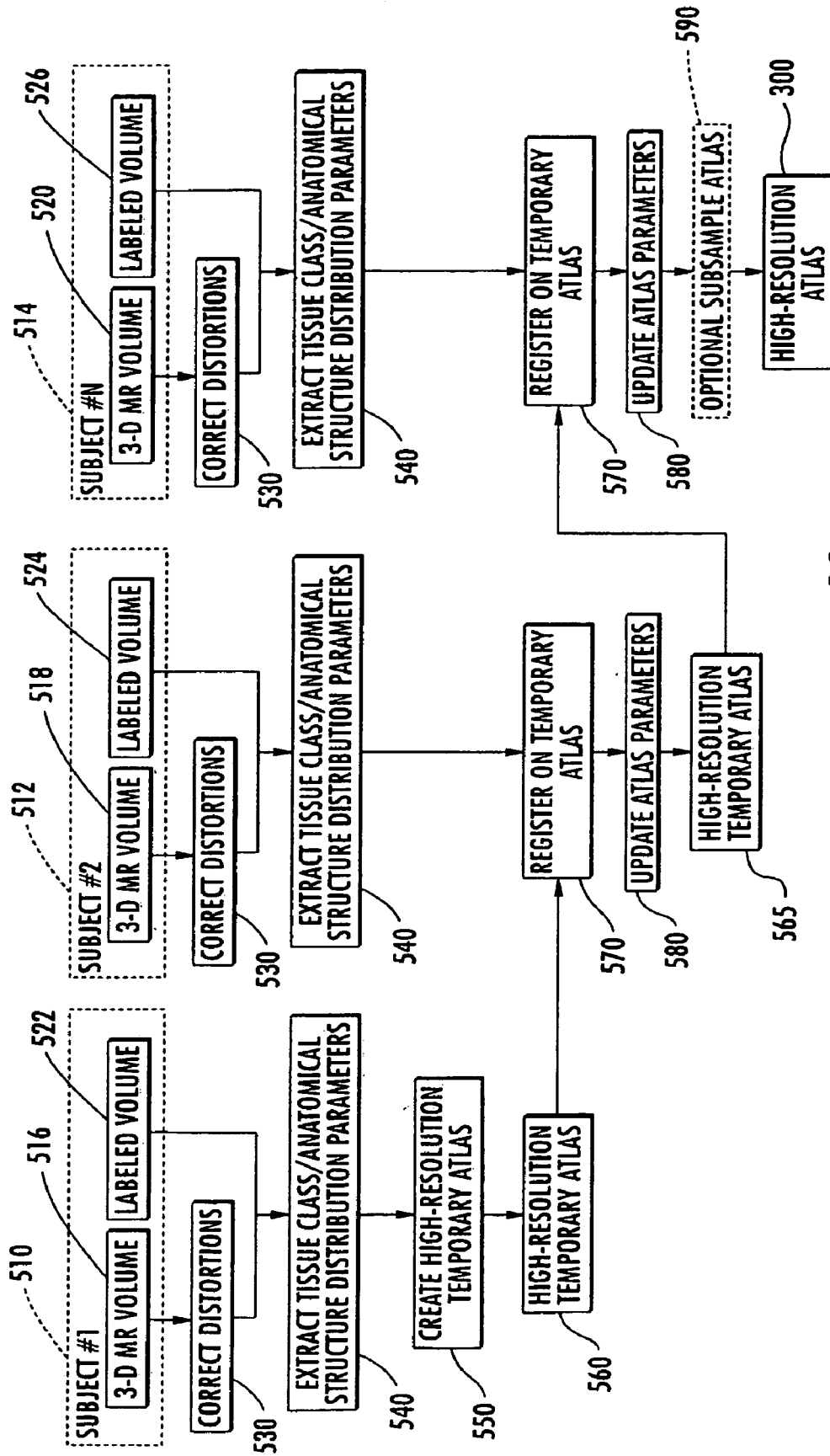

FIGURE 10

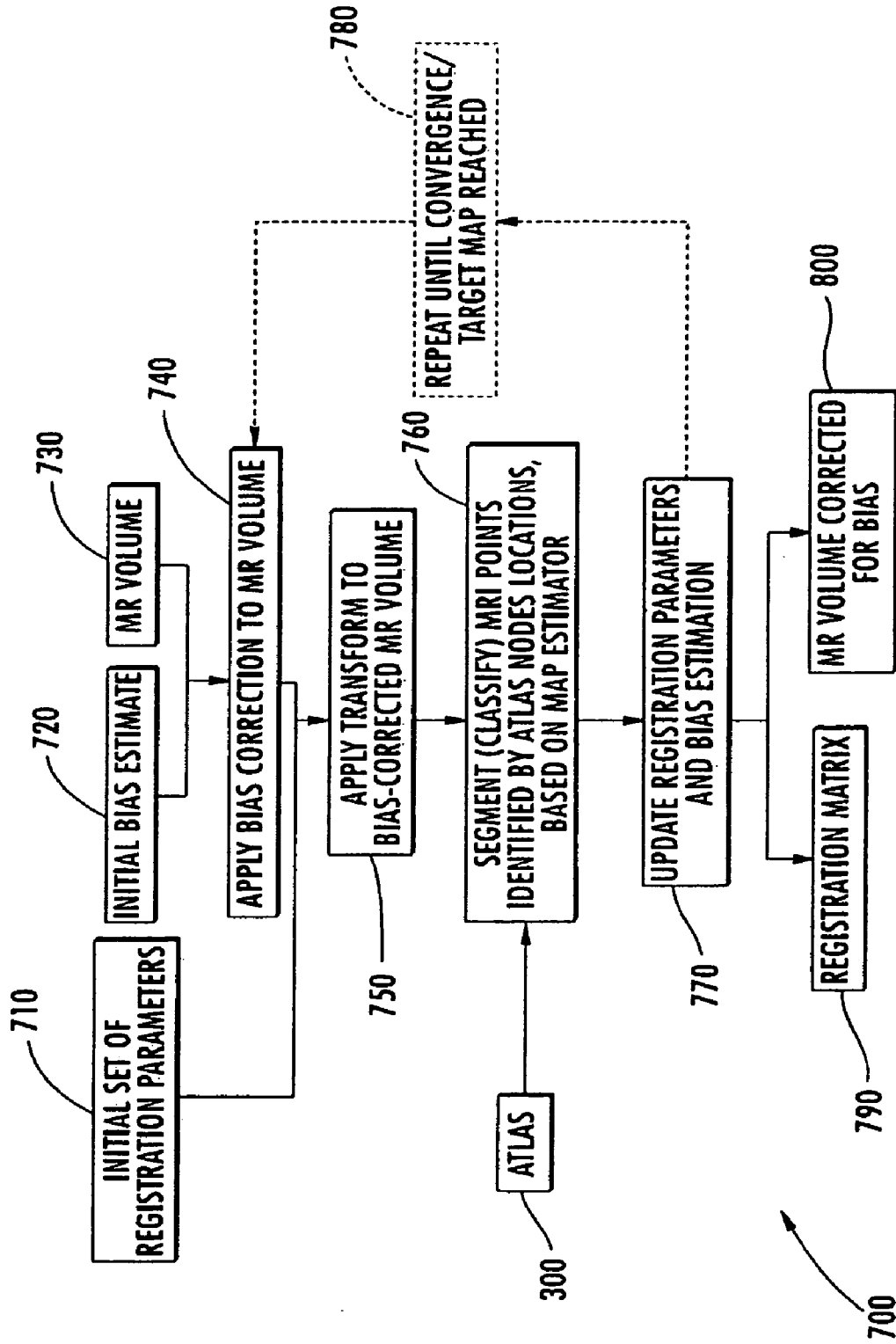

FIGURE 11

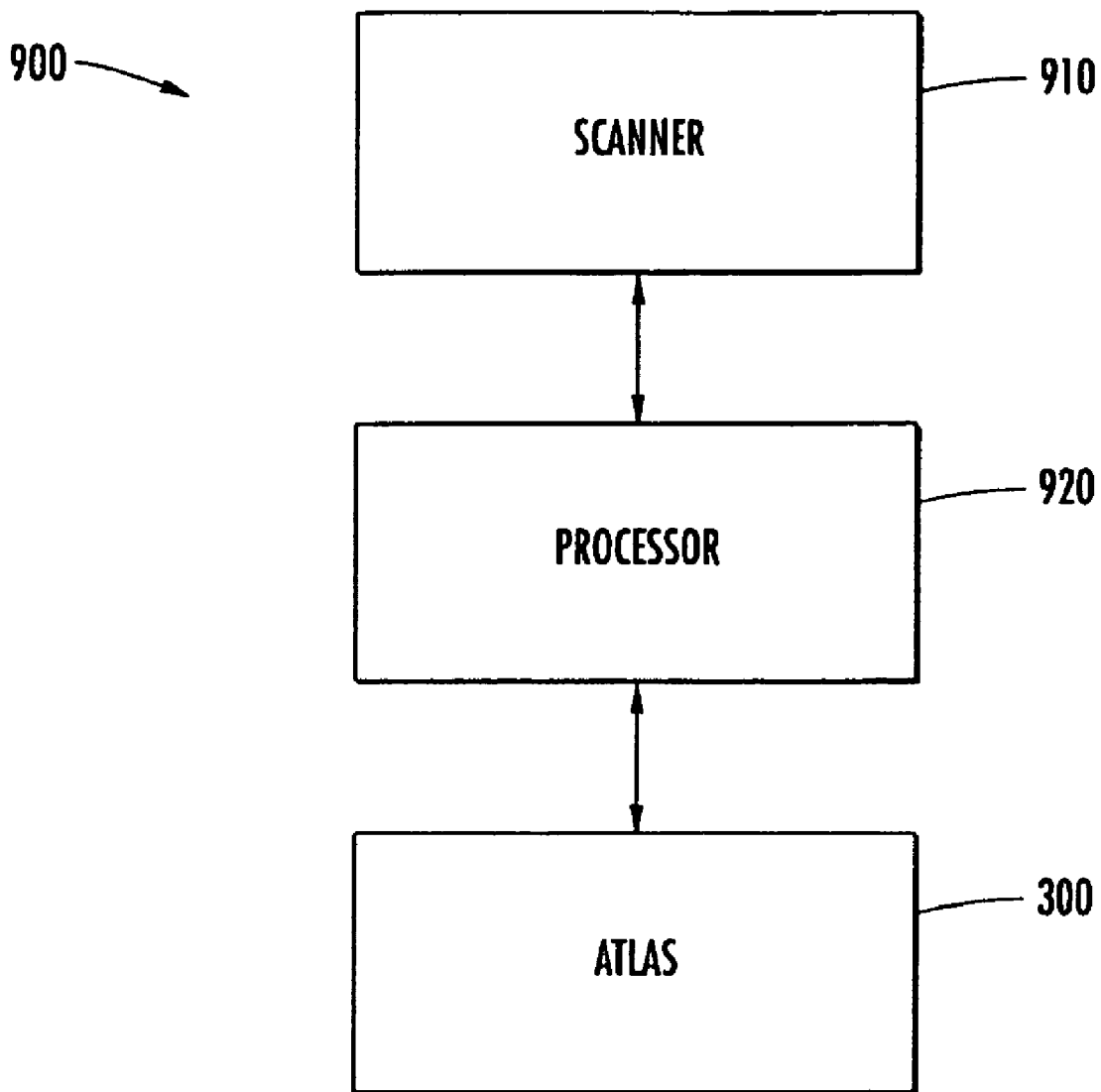

FIGURE 12

**ATLAS AND METHODS FOR
SEGMENTATION AND ALIGNMENT OF
ANATOMICAL DATA**

RELATED APPLICATIONS

[0001] This application is a continuation of U.S. patent application Ser. No. 10/055,256, filed Jan. 22, 2002, the entire contents of which are incorporated herein by reference.

TECHNICAL FIELD

[0002] The present invention generally relates to magnetic resonance and other biological scan data.

BACKGROUND

[0003] Magnetic resonance imaging is a complex interaction between protons in biological tissues, a static and alternating magnetic field (the magnet), and energy in the form of radio-frequency waves of a specific frequency (RF), introduced by coils placed next to the subject. The energy state of the hydrogen protons is transiently increased. The subsequent return to equilibrium (relaxation) of the protons results in the release of RF energy which can be measured by the same surface coils that delivered the RF pulses. The RF energy, also referred to as the RF signal or echo, is complex and is thus transformed by Fourier analysis into useful information used to form an MR image.

SUMMARY

[0004] The present invention provides apparatus and methods for processing data associated with magnetic resonance (MR) scanning. In particular, in one embodiment, the present invention provides an atlas comprising at least one value representative of a magnetic property and, optionally, at least one value representative of tissue type prior probability. In a further embodiment, the present invention provides an atlas comprising a plurality of values representative of magnetic properties of a plurality of spatial locations of a plurality of subjects. In one embodiment, a system is provided having both an MR scanner and an atlas of the present invention. In a further embodiment, the invention provides methods of making and using the atlas and system.

[0005] The apparatus and methods of the present invention provide a model having data representative of one or more subjects. The data includes magnetic property values, optionally, tissue type prior probability values. The atlas can be used to automatically align an MR scan, such as a localizer scan, to obtain a specific geometry of the data acquired during a subsequent scan. The atlas may also be used to automatically identify, or segment, tissue type of a subject based on MR scan data of the subject.

[0006] According to one embodiment of the invention, an atlas is provided comprising a plurality of values representative of a magnetic property of a plurality of spatial locations of a subject as determined by magnetic resonance. According to a further embodiment, an atlas is provided comprising values representative of a statistical representation of a magnetic property of a plurality of spatial locations of a plurality of subjects. The present invention also provides a system comprising an MR scanner and an atlas. For example, the atlas may contain magnetic property data. The system can be used to automatically align an MR scan, such as a localizer scan, to obtain a specific orientation of the data acquired during a subsequent scan. The system may also be used to

automatically identify, or segment, tissue type of a subject based on MR scan data of the subject.

[0007] Methods of using the atlas are further provided herein. In one embodiment, a method of using the atlas having magnetic property values to obtain a specific geometry of data to be acquired during a subsequent scan is provided. In a variation of this embodiment, a method of using the atlas may additionally involve tissue type probabilities.

[0008] Methods of using the atlas are further provided herein. In one embodiment, a method of using the atlas having magnetic property values to determine tissue type is provided. In a variation of this embodiment, a method of using the atlas may additionally involve tissue type probabilities.

[0009] According to a further embodiment of the invention, a method is provided for obtaining information about a subject having the steps of providing a magnetic resonance scanner, providing an atlas having magnetic resonance data derived from at least one other subject and processing information received from the scanner pertaining to the subject. Also included are the steps of reading the atlas and determining alignment of the magnetic resonance scan to obtain a specific geometry of a subsequent magnetic resonance scan.

[0010] According to another embodiment of the invention, another method is provided for obtaining information about a subject. This method involves the steps of providing magnetic property values corresponding to tissue types pertaining to the subject, providing an atlas having magnetic property values derived from at least one other subject, along with labeling tissue types of a tissue corresponding to the magnetic resonance property values pertaining to the subject by using the atlas having the magnetic resonance values derived from at least one other subject.

[0011] According to a further embodiment of the invention, a method is provided for creating an atlas by providing a first magnetic resonance modality volume pertaining to a subject, divided into voxels, and recording a magnetic property value in a node of the atlas corresponding to a voxel of the first magnetic resonance modality volume.

[0012] Another embodiment of the invention involves a method for creating an atlas. A first magnetic resonance modality volume is provided pertaining to a subject and divided into voxels. A labeled volume is provided indicating tissue types of tissue corresponding to the voxels. Distortion of the first magnetic resonance modality volume is corrected. Magnetic property distribution parameters are extracted for each tissue type identified at each voxel. Also, magnetic property data is recorded corresponding to each tissue type in a node of the atlas corresponding to a voxel of the first magnetic resonance modality volume.

[0013] According to another embodiment, a method for creating an atlas is provided wherein a voxel intensity is obtained from an image representative of at least one magnetic modality of a voxel of a subject, a magnetic property value is derived from the voxel intensity, and the magnetic property value is written to a node of the atlas corresponding to the voxel.

[0014] A further embodiment of the invention provides a method for processing an image of a subject. An atlas is provided having magnetic property values derived from at least one other subject. The image is aligned to the atlas, and the image is segmented into segments. The segments are labeled to designate a tissue type of a tissue corresponding to the magnetic property values pertaining to the subject by the

use of the atlas. An image is thus obtained pertaining to magnetic property values of the subject.

[0015] It will further be appreciated that in the methods of the present invention, distortion may be corrected prior to entering the data into the atlas, as well as prior to processing newly acquired data in conjunction with the atlas.

BRIEF DESCRIPTION OF THE DRAWINGS

[0016] The invention will be apparent from the description herein and the accompanying drawings, in which like reference characters refer to the same parts throughout the different views.

[0017] FIG. 1 provides a subject and a grid pattern illustrating voxels of a subject;

[0018] FIG. 2 illustrates an atlas;

[0019] FIGS. 3-8 illustrate nodes of an atlas according to various embodiments of the invention;

[0020] FIGS. 9A and 9B illustrate sample data for determination of the content of a node of an atlas;

[0021] FIG. 10 provides a sample method for the creation of an atlas;

[0022] FIG. 11 provides a sample method for the registration of MR data to an atlas; and

[0023] FIG. 12 provides a functional schematic of a system according to an embodiment of the invention.

DETAILED DESCRIPTION

[0024] The present invention, in various embodiments, involves an atlas containing values representative of magnetic properties of a magnetic resonance (MR) scan and optionally prior probability data relating to tissue type. Further embodiments of the invention involve a system including an MR scanner and the atlas for use, for example, in alignment of an MR scan and for automatic segmentation of an MR scan. Methods of creating and using the atlas and system are also provided.

[0025] As used herein, the following terms are defined as follows:

[0026] T1 and T2 relaxation times: The rate of return to equilibrium of perturbed protons is referred to as the relaxation rate. The relaxation rate is different for different normal and pathologic tissues. The relaxation rate of a hydrogen proton in a tissue is influenced by surrounding molecular environment and atomic neighbors. Two relaxation rates, the T1 and T2 relaxation times, may be measured. The T1 relaxation rate is the time for 63% of the protons to return to their normal equilibrium state, while the T2 relaxation rate is the time for 63% of the protons to become dephased owing to interactions among adjacent protons. The intensity of the signal and thus the image contrast can be modulated by altering certain parameters, such as the interval between RF pulses (TR) and the time between the RF pulse and the signal reception (TE). So-called T1-weighted (T1W) images are produced by keeping the TR and TE relatively short. Under these conditions, contrast between structures is based primarily on their T1 relaxation differences. T2-weighted (T2W) images are produced by using longer TR and TE times.

[0027] TR: The time between repetitions of RF in an imaging sequence.

[0028] TE: The time between the RF pulse and the maximum in the echo in a spin-echo sequence.

[0029] Flip Angle: The angle that the magnetic moment vector rotates when applying a B1 RF pulse field.

[0030] T1: The time to reduce the difference between the longitudinal magnetization and its equilibrium magnetization by an exponential factor.

[0031] T2: The time to reduce the transverse magnetization by an exponential factor.

[0032] PD: The concentration of spins.

[0033] T1-weighted: A magnetic resonance image where the contrast is predominantly dependent on T1.

[0034] T2-weighted: A magnetic resonance image where the contrast is predominantly dependent on T2.

[0035] PD-weighted: A magnetic resonance image where the contrast is predominantly dependent on PD.

[0036] Diffusion-weighted: A magnetic resonance image where the contrast is predominantly dependent on diffusion weighting gradient.

[0037] Magnetization Transfer-weighted: A magnetic resonance image where the contrast is predominantly dependent on magnetization transfer saturation effect.

[0038] Tissue Type: As used herein, "tissue type" can be used to designate a classification or characteristic of a tissue, such as tissue within a voxel. For example, when used with a human brain as the subject, tissue type can include, without limitation, gray matter, white matter and cerebral spinal fluid. Optionally, the tissue type can be more specific, such as referring to anatomical structure. For example, in the case of a brain as the subject, the tissue type may designate gray matter and/or, more specifically, hippocampus, or other appropriate anatomical structure label. In another example, in the case of a spine as a subject, the tissue type may designate bone, and/or more specifically vertebral bodies, or other appropriate anatomical structure labels. In yet another example, in the case of the kidney as a subject, the tissue type may designate the cortex, and/or more specifically nephrons, or other appropriate anatomical structure labels.

[0039] Localizer scan: A low-resolution scan acquired at the beginning of a scanning procedure to estimate the precision of the acquisition geometry relative to the subject to be imaged.

[0040] Subsequent scan: A high-resolution scan acquired on the basis of the localizer geometry, such as orientation, dimensions, or voxel size.

[0041] Magnetic property: A magnetic property of protons, such as T2, T1, PD, diffusion or magnetization transfer.

[0042] The present invention is applicable to a wide variety of MR scans of a subject including mammals (e.g. humans), as well as specific portions of a subject (e.g., organ, limb, or a portion of an organ or limb), also referred to herein as the "subject". Each subject is divided in three-dimensional space into voxels. With reference to FIG. 1, a subject 100, such as a human brain, is shown with an illustrative grid pattern 200 signifying the locations of voxels 210. Each voxel 210 represents a three-dimensional portion of the subject 100. A voxel 210 may be of various dimensions and can have different dimensions along different axes within the subject 100.

[0043] As shown in FIG. 2, an atlas 300 is provided according to an embodiment of the invention. While illustrated as a three-dimensional structure, the invention is not so limited, as the atlas 300 may be formed of any of a variety of data structures as will be apparent to one of ordinary skill in the art. The atlas 300 includes nodes 310. According to an embodiment of the invention, each node 310 corresponds to a voxel 210 (cf. FIG. 1) representing a portion of the subject 100. Alternatives of the invention may involve fewer nodes 310 than voxels 210. In such a case, a node 310 may be configured

to represent a plurality of voxels **210** or the nodes **310** may represent only a subset of the overall voxels **210**.

[0044] FIGS. 3-8 provide various configurations of the nodes **310** according to alternative embodiments of the invention. Each node **310** is configured to store information relating to the corresponding voxel **210**. As shown in FIG. 3, the node **310** may be configured to have a magnetic property **320** corresponding to the voxel **210**. magnetic properties may include, but are not limited to, T1, T2, proton density (PD), T2*, magnetization transfer, diffusion tensor and derived variables, such as anisotropy and diffusivity. According to one embodiment of the invention, the magnetic properties may be computed from the images, based on a forward model, and the MR acquisition parameters, including, but not limited to, TR, TE, and flip angle. Determination of such magnetic properties and details regarding the MR acquisition parameters can be found in *Magnetic Resonance Imaging, Physical Principle and Sequence Design*, E. M. Haacke et al., Wiley-Liss, 1999, pp. 637-667, which is incorporated herein by reference.

[0045] Optionally, a second magnetic property **330** corresponding to the voxel **210** may also be stored in the node **310**. Additional magnetic properties may also be stored in the node **310**.

[0046] A tissue type prior probability **340** corresponding to a tissue type found in the voxel **210** may optionally be stored in the node **310**. When used with a human brain as the subject, tissue type can include, without limitation, gray matter, white matter and cerebral spinal fluid. Optionally, the tissue type can be more specific, such as referring to anatomical structure. For example, in the case of a brain as the subject, the tissue type may designate gray matter and/or, more specifically, the hippocampus, or other appropriate anatomical structure label. In another example, in the case of the spine as a subject, the tissue type may designate bone, and/or more specifically vertebral bodies, or other appropriate anatomical structure labels. In yet another example, in the case of the kidney as a subject, the tissue type may designate the cortex, and/or more specifically nephrons, or other appropriate anatomical structure labels. It will be appreciated that the tissue type of the voxel **210** may be determined by human labeling or may be determined by other known methods such as an algorithm (e.g. *Adaptive Segmentation of MRI Data*, Wells W M, et al., *IEEE Transactions on Medical Imaging*, 1996;15: 429-442 (corrected version available at <http://citeseer.nj.nec.com/cache/papers/cs/19782/http://zSzzSzsplweb.bwh.harvard.edu:8000zSzpageszSzplzSzswzSzpaperszSztmi-96.pdf/wells96adaptive.pdf>), *Statistical Approach to Segmentation of Single-Channel Cerebral MR Images*, Rajapakse J C, et al., *IEEE Transactions on Medical Imaging*, 1997, Vol. 16, No. 2: 176-86, and *Automated Model-Based Bias Field Correction of MR Images of the Brain*, Van Leemput, K. et al., *IEEE Transactions on Medical Imaging*, 1999, Vol. 18, No. 10), which are incorporated herein by reference.

[0047] According to a further embodiment of the invention, a node **310** may include a tissue type prior probability **340** corresponding to a tissue type found in the voxel **210**, as illustrated in FIG. 4. According to this embodiment, a first magnetic property **320** is also stored. Optionally, a second magnetic property **330**, or additional magnetic properties, may also be stored in the node **310**.

[0048] According to a further embodiment of the invention, as shown in FIG. 5, one or multiple magnetic properties may be determined for each of the tissue types located at the

corresponding voxel **210**. Therefore, as shown by way of example in FIG. 5, if a voxel **210** has two tissue types located at the voxel **210**, as determined from a plurality of subjects, one or more magnetic properties **320**, **330** may be stored for each of the tissue types. As shown in FIG. 5, a value of a first magnetic property **320** may be stored for the tissue type **1** at the corresponding voxel. Optionally, a value of a second magnetic property **330** may also be stored for tissue type **1**. Separate magnetic properties **320**, **330** may also be stored for the values corresponding to the tissue of tissue type **2**. This variation of the invention is useful in conjunction with an atlas **300** formed of information from more than one subject **100**. A tissue type probability **340** may also be optionally stored in the node **310** for one or more of the tissue types detected at the corresponding voxel **210**.

[0049] In a further embodiment, illustrated by way of example in FIG. 6, a tissue type prior probability **340** may be stored at a node **310** for each tissue type located at a corresponding voxel **210**. A magnetic property **320** is also stored at the node **310** for each tissue type. Optionally, one or more further magnetic properties **330** may also be stored at the node **310**.

[0050] A further embodiment of a node **310** is illustrated in FIG. 7. The node **310** of FIG. 7 provides a tissue type prior probability **340** and statistical data pertaining to a magnetic property of the tissue of a corresponding voxel **210**, relative to a plurality of subjects. As shown by way of example in FIG. 7, a mean **322** of the values of a first magnetic property for a first tissue type at the corresponding voxel **210** is provided. A variance **324** of the values of a first magnetic property for the first tissue type at the corresponding voxel **210** is also provided.

[0051] The node **310** of FIG. 7 may also optionally include statistical data pertaining to one or more additional magnetic properties, such as a mean **332** and variance **334** of a second magnetic property.

[0052] The node **310** of FIG. 7 is also optionally suitable for use with an atlas **300** containing information from a plurality of subjects **100**. Any of the data **322**, **324**, **332**, **334**, **340** as described above in relation to a first tissue type, may also be determined in relation to a second tissue type and stored.

[0053] FIG. 8 illustrates a node **310** of a further embodiment of the invention providing statistical data, such as a mean **322** and a variance **324**, of the values of a first magnetic property for a first tissue type at a corresponding voxel **210**. Optionally, further statistical data **332**, **334** or a tissue type prior probability **340** may be provided. Similar information **322**, **324**, **332**, **334**, **340** may also be optionally provided relating to further tissue types at a corresponding voxel **210**.

[0054] As illustrated by way of example in FIGS. 9A and 9B, the determination of a mean **322** and a variance **324** for a first magnetic property can be determined. FIG. 9A provides a table **400** having the sample magnetic property values for an analogous voxel of each of three subjects. FIG. 9B illustrates the three steps **410**, **420**, **430** involved in determining the content of the node **310** corresponding to the illustrative voxel. As shown in step **1**, **410**, the tissue type is **1**, the mean of the value is **100** and the variance is **0**. The prior probability of this node corresponding to a voxel of tissue type **1** is **1**. Step **2**, **420**, adds the data of the second subject to the data already tabulated from the first subject. Therefore, the mean now rises to **150**, while the remaining data is unchanged, as the tissue type is **1** for both subjects, leaving the prior probability at **1**.

[0055] Step 3, 430, illustrates a node configuration illustrated in FIG. 7 or 8 by the tabulation of statistical data per tissue type for each node. Because the tissue type for the third subject is 2, a second set of statistical data is tabulated for the new tissue type, while the first set of data is updated in view of the third subject. The mean and variance of tissue type 1 remain unchanged. The prior probability of tissue type 1 however, now changes to $\frac{2}{3}$. The mean of tissue type 2 is 50, and the variance 0. The prior probability of tissue type 2 is $\frac{1}{3}$.

[0056] In another embodiment, additional data may be stored at each node relating to the corresponding voxel or a representation thereof. For example, image intensity data, expressed in arbitrary units, may be stored. Alternatives include those apparent to one of skill in the art.

[0057] In another embodiment, global prior probabilities may be stored in the atlas of the present invention. Global probabilities indicate the overall prior probability of something, such as a tissue type appearing in a particular area, or anywhere, in a subject. The global mean and variance of various magnetic properties may also be determined and stored for each tissue type. Such global values may be stored at a variety of locations in the atlas, such as in a header, or alternatively, at each node.

[0058] As shown by way of example in FIG. 10, a method 500 is provided according to an embodiment of the invention for the creation of an atlas 300. The atlas is built from one or more subject data sets 510, 512, 514. A subject data set may contain at least one MR scan 516, 518, 520 of a subject (e.g. an organ or a portion of an organ). The MR scans can be, but are not limited to, T1, T2, proton density (PD), T2*, magnetization transfer, diffusion tensor or derived variables such as anisotropy and diffusivity.

[0059] Distortions are then corrected in the MR scan 516, step 530. Corrections of distortion are known to one of ordinary skill in the art and are discussed in more detail in relation to FIG. 11 herein.

[0060] According to one embodiment, a subject's data set used in creating or adding to an atlas can also contain a labeled representation 522, 524, 526 of the MR scan(s), such as a segmented volume identifying each tissue type/anatomical structure. The labeled representation can be obtained by way of manual labeling (e.g. by experienced anatomists) and/or by way of automatic segmentation methods as described by way of example in Wells, supra, *Statistical Approach to Segmentation of Single-Channel Cerebral MR Images*, Rajapakse J C, et al., *IEEE Transactions on Medical Imaging*, 1997, Vol. 16, No. 2: 176-86, and *Automated Model-Based Bias Field Correction of MR Images of the Brain*, Van Leemput, K. et al., *IEEE Transactions on Medical Imaging*, 1999, Vol. 18, No. 10, which are incorporated herein by reference.

[0061] Next, the tissue type and corresponding magnetic property statistical distribution data is extracted from the corrected subject data set 510, step 540.

[0062] A high-resolution temporary atlas 560, step 550, is then created by storing the tissue type and corresponding magnetic property statistical data of each voxel 210 of the subject, in each corresponding node 310 of the atlas 300.

[0063] The high-resolution temporary atlas 560 may then be used as the atlas 300 if the atlas 300 is to only have data pertaining to a single subject.

[0064] However, if additional subjects are to be added, the method 500 continues with the subject data set 512 of a second subject, and, optionally subject data sets 514 of addi-

tional subjects. Correction of distortion, step 530, and extraction of statistical data 540 is conducted as in relation to the first subject data set 510.

[0065] After each additional subject data set 512, 514 is processed, the tissue type and corresponding magnetic property statistical data of each voxel 210 of the subject is registered, or aligned, with the existing node structure of the atlas 300, step 570. During registration, the data, such as tissue type and magnetic statistical data, corresponding to the voxels 210 of the subject, is manipulated to correspond to the analogous voxels 210 represented by the node 310 structure of the atlas. Further details of registration, step 570, are discussed in detail in relation to FIG. 11 herein.

[0066] Next, the additional data, such as tissue type and magnetic statistical data, is then added to the atlas 300 by updating the atlas parameters, step 580. As shown in FIG. 10, a high-resolution atlas 565 is produced after the addition of two subject data sets 510, 512 to the atlas 300. This high-resolution atlas 565 may be used as an atlas 300, or additional subject data sets 514 may be added.

[0067] When the desired N subject data sets have been added to the atlas, the atlas may optionally be subsampled, step 590 to create the atlas 300. As discussed herein, alternatives of the invention may involve fewer nodes 310 than voxels 210. In such a case, a node 310 may be configured to represent a plurality of voxels 210 or the nodes 310 may represent only a subset of the overall voxels 210. Such a reduced resolution may also be generated by the subsampling, step 590, by combining data from multiple voxels into one node. Also, only a portion of the voxels representing a portion of the subject may be used in the atlas 300.

[0068] An atlas 300 of the present invention may be customized for a specialized purpose. The atlas may have values of a statistical representation that are population-specific (e.g., related to age, sex and/or pathology), scanner-specific (e.g., related to manufacturer and/or scanner model), and/or acquisition sequence-specific (e.g., related to flash and/or inversion recovery). Acquisition sequences can include including, without limitation, at least one from the group of PD-, T2-, T1-, diffusion-, and magnetization transfer-weighted. Acquisition sequence-specific values may involve magnetic resonance sequence parameters, including, without limitation, at least one from the group of TR, TE and flip angle.

[0069] An atlas of the present invention may be oriented to various coordinate systems. One such example of a coordinate system is a Cartesian coordinate system, such as a Right Anterior Superior (RAS) coordinate system, used in orienting an image relative to a subject, or an arbitrarily determined coordinate system.

[0070] An atlas of the present invention may be created at various spatial resolutions. An atlas may further be subsampled to reduce the resolution and data required and time required for calculations. The resolution may also vary within an atlas, allowing greater resolution at areas of interest.

[0071] According to one embodiment of the invention, an atlas may be constructed as shown in FIGS. 10 and 11. Optionally, an atlas may be formed by data from only one subject. An atlas may be formed by N subjects, which may be determined by monitoring the change of values within the atlas upon the addition of each additional subject. According to another embodiment, when the values stored in the nodes of the atlas no longer vary within a statistical range of confidence, the addition of further subjects is no longer required.

[0072] The registration of data onto the atlas may comprise the determination of at least 6 parameters. For example, those parameters can be 3 translation shifts, 3 scaling factors and 3 rotation angles relatively to the 3 orthogonal directions of the atlas coordinate system.

[0073] Further detail regarding registration of data onto an atlas, or temporary atlas as described in FIG. 10, is illustrated by way of example in the method 700 of FIG. 11. In FIG. 11, a method 700 is provided according to an embodiment of the invention for the registration of MR data to an atlas 300. The example method 700 of FIG. 11 is also applicable to prior probability data or any other data types for association to nodes 310 of the atlas 300.

[0074] An initial set of registration parameters is provided, step 710, along with an initial bias estimate, step 720, according to methods known to one of skill in the art in relation to atlases having other types of data. See, for example, Wells, supra, *Automated Model-Based Bias Field Correction of MR Images of the Brain*, Van Leemput, K. et al., *IEEE Transactions on Medical Imaging*, 1999, Vol. 18, No. 10, and *Automatic Scan Prescription for Brain MRI*, Itti, L. et al., *Magnetic Resonance in Medicine*, 2001, Vol. 45: 486-494, which are incorporated herein by reference. The initial bias estimate of step 720 adjusts for intensity fall-off in the portions of the image away from the image center.

[0075] A magnetic resonance (MR) volume is also provided, step 730. The magnetic resonance volume can be generated by deriving a magnetic property value for a voxel from a voxel intensity value of a corresponding voxel of an image containing magnetic resonance data.

[0076] A bias correction is applied to the MR volume, step 740. With regard to step 740, and step 530 of FIG. 10, distortion and bias can be caused by a variety of factors. For example, the distortion and bias can be subject-dependent, such as from, but not limited to, chemical shift, magnetic susceptibility, and/or per-acquisition motion. Alternatively or in addition, distortion and bias can be scanner-dependent, such as from, but not limited to, gradients non-linearity, main magnetic field non-homogeneity and/or eddy currents. Maxwell effects are a further source of potential distortion or bias. Correction of such distortion and bias are known to one of ordinary skill in the art.

[0077] As shown in FIGS. 10 and 11, bias and distortion are corrected prior to incorporating the data into the atlas. According to a further embodiment of the invention, distortion and bias are corrected prior to processing data in conjunction with the atlas.

[0078] A transform is applied to the bias-corrected MR volume, step 750. Linear transformations (e.g. translation, rotation, scaling) are applied to images via homogeneous matrices. According to one embodiment, they are 4x4 matrices, wherein the 3 first bottom elements always equal 0 and the last bottom elements always equals 1. Any transformation can be decomposed into a translation, a rotation and a scaling matrices. The final homogeneous matrix is then a multiplication of those 3 matrices. Details are given by way of example below:

[0079] t_x , t_y and t_z being the translation parameters in the x, y and z directions, the translation homogeneous matrix is given by:

$$\begin{pmatrix} 1 & 0 & 0 & t_x \\ 0 & 1 & 0 & t_y \\ 0 & 0 & 1 & t_z \\ 0 & 0 & 0 & 1 \end{pmatrix}$$

[0080] x_s , y_s and z_s being the scaling parameters in the x, y and z directions, the scaling homogeneous matrix is given by:

$$\begin{pmatrix} x_s & 0 & 0 & 0 \\ 0 & y_s & 0 & 0 \\ 0 & 0 & z_s & 0 \\ 0 & 0 & 0 & 1 \end{pmatrix}$$

[0081] θ , ϕ and ψ being the rotation parameters relatively to the x, y and z axis, the rotation homogeneous matrix is given by:

$$\begin{pmatrix} \cos\psi\cos\phi + \sin\psi\sin\theta\sin\phi & \sin\psi\cos\theta - \cos\psi\sin\theta\sin\phi & \cos\theta\sin\psi & 0 \\ -\sin\psi\cos\theta & \cos\psi\cos\theta & \sin\theta & 0 \\ \sin\psi\sin\theta\cos\phi - \cos\psi\sin\theta & -\cos\psi\sin\theta - \sin\psi\sin\theta & \cos\theta\cos\psi & 0 \\ 0 & 0 & 0 & 1 \end{pmatrix}$$

[0082] The voxels, or MRI points, corresponding to nodes 310 of the atlas 300 are segmented based on a Maximum A Posteriori (MAP) estimator, step 760. The MAP estimator is a probability computation with statistical information stored in the atlas. The MAP estimator and its use with other types of data are known to one of ordinary skill in the art, as illustrated by way of example in Wells, supra, *Statistical Approach to Segmentation of Single-Channel Cerebral MR Images*, Rajapakse J C, et al., *IEEE Transactions on Medical Imaging*, 1997, Vol. 16, No. 2: 176-86, and *Automated Model-Based Bias Field Correction of MR Images of the Brain*, Van Leemput, K. et al., *IEEE Transactions on Medical Imaging*, 1999, Vol. 18, No. 10, which are incorporated herein by reference.

[0083] The registration parameters and bias estimation are then updated, step 770, as is known to one of ordinary skill in the art, as illustrated by way of example in Wells, supra, *Automated Model-Based Bias Field Correction of MR Images of the Brain*, Van Leemput, K. et al., *IEEE Transactions on Medical Imaging*, 1999, Vol. 18, No. 10, and *Multimodality Image Registration by maximization of Mutual Information*, Maes, F. et al., *IEEE Transactions on Medical Imaging*, 1997, Vol. 16, No. 2, which are incorporated herein by reference. If the target MAP is not reached, the process repeats, step 780, beginning again with application of bias correction to the MR volume, step 740.

[0084] If the target MAP is reached, the registration matrix is provided, step 790. The registration matrix can include sixteen (16) values, including translation parameters, scaling parameters, and a combination of the sines and cosines of rotation parameters. The registration matrix can be used to obtain a specific geometry (e.g. orientation and/or dimensions) of the data acquired during a subsequent scan, as discussed herein.

[0085] The MR volume corrected for bias is also provided, step **800**, allowing more accurate computation of the magnetic property values for each node of the atlas.

[0086] Further information regarding the details of the steps of FIG. **11** can be found in Wells, supra, *Automated Model-Based Bias Field Correction of MR Images of the Brain*, Van Leemput, K. et al., *IEEE Transactions on Medical Imaging*, 1999, Vol. 18, No. 10, and *Multimodality Image Registration by Maximization of Mutual Information*, Maes, F. et al., *IEEE Transactions on Medical Imaging*, 1997, Vol. 16, No. 2, which are incorporated herein by reference.

[0087] According to a further embodiment of the invention, a system **900** is provided as shown by way of example in FIG. **12**. A scanner **910** is provided to capture magnetic images. A processor **920** is provided to interface with the scanner **910** and the atlas **300** in order to conduct the methods according to various embodiments of the present invention.

[0088] The atlas and system **900** of the present invention may be used in a variety of applications. In one embodiment, a method of using the atlas with magnetic property data and optionally with tissue (or anatomical structure) type prior probabilities is provided, automatically align an MR scan, such as a localizer scan, to obtain a specific geometry of the data acquired during a subsequent scan (auto-slice prescription). Further details of this implementation can be found in U.S. Pat. No. 6,195,409, issued Feb. 27, 2001, to Chang et al., which is incorporated herein by reference. In an additional embodiment, a method of using the atlas with magnetic property data to determine anatomical structure or detect abnormal tissue (auto-segmentation) is provided. Further details of this implementation can be found in Wells, supra, *Statistical Approach to Segmentation of Single-Channel Cerebral MR Images*, Rajapakse J. C., et al., *IEEE Transactions on Medical Imaging*, 1997, Vol. 16, No. 2: 176-86, and *Automated Model-Based Bias Field Correction of MR Images of the Brain*, Van Leemput, K. et al., *IEEE Transactions on Medical Imaging*, 1999, Vol. 18, No. 10, which are incorporated herein by reference.

[0089] It will further be appreciated that in the methods of the present invention, including the applications described herein, distortion of newly obtained data may optionally be corrected prior to processing data in conjunction with the atlas. Further details of distortion correction can be found in *Sources of Distortion in Functional MRI Data*, Jezzard, P. et al., *Human Brain Mapping*, 1999, Vol. 8:80-85, which is incorporated herein by reference.

[0090] The present invention has been described by way of example, and modifications and variations of the described embodiments will suggest themselves to skilled artisans in this field without departing from the spirit of the invention. Aspects and characteristics of the above-described embodiments may be used in combination. The described embodiments are merely illustrative and should not be considered restrictive in any way. The scope of the invention is to be measured by the appended claims, rather than the preceding description, and all variations and equivalents that fall within the range of the claims are intended to be embraced therein. The contents of all references, databases, patents and published patent applications cited throughout this application are expressly incorporated herein by reference.

What is claimed is:

1. A prior probability MRI based atlas embodied on a computer-readable medium comprising:

a plurality of nodes corresponding to a plurality of voxels representing spatial locations of a subject, each of the nodes configured to store:

at least two magnetic property values for each of the voxels as determined by magnetic resonance imaging of a plurality of subjects, wherein the at least two magnetic property values correspond to tissue type at one or more voxels; and

prior probability data relating to tissue type at one or more voxels, wherein the tissue type prior probability is determined from measurements of at least one subject.

2. The atlas of claim **1**, wherein the plurality of nodes represent the subject divided in three-dimensional space.

3. The atlas of claim **1**, wherein each node in the plurality of nodes corresponds to a voxel in the plurality of voxels.

4. The atlas of claim **1**, wherein each node in the plurality of nodes corresponds to more than one voxel in the plurality of voxels.

5. The atlas of claim **1**, wherein the at least two magnetic property values of each of the voxels comprise T1 values and T2 values.

6. The atlas of claim **5**, wherein the at least two magnetic property values of each of the voxels further comprise proton density values.

7. The atlas of claim **1**, wherein the at least two magnetic property values represent different magnetic properties.

8. The atlas of claim **1**, wherein the at least two magnetic property values correspond to a first tissue type at one voxel and a second tissue type at a second voxel.

9. The atlas of claim **1**, wherein the at least two magnetic property values correspond to a first tissue type at one voxel and a second tissue type at a second voxel.

10. A prior probability MRI based atlas embodied on a computer-readable medium comprising:

a plurality of nodes corresponding to a plurality of voxels representing spatial locations of a subject, each of the nodes configured to store:

at least one magnetic property value as determined by magnetic resonance imaging of at least one subject; and

at least one tissue type prior probability value corresponding to a tissue type of one or more voxels in the plurality of voxels as determined from measurements of the at least one subject.

11. The atlas of claim **10**, wherein each of the nodes is also configured store a second tissue type prior probability value corresponding to a second tissue type of one or more voxels in the plurality of voxels as determined from measurements of the at least one subject.

12. The atlas of claim **10**, wherein the at least one magnetic property value as determined by magnetic resonance imaging of at least one subject is determined by magnetic resonance imaging of a plurality of subjects; and wherein the at least one tissue type prior probability value corresponding to a tissue type of one or more voxels in the plurality of voxels as determined from measurements of the at least one subject is determined from measurements of the plurality of subjects.

13. A prior probability MRI based atlas embodied on a computer-readable medium comprising:

- a plurality of nodes, each node configured to store:
 - statistical values calculated from a statistical representation of measured values of at least one magnetic property as determined by magnetic resonance imaging; and
 - statistical values calculated from a statistical representation of prior probability values corresponding to a tissue type for each of a plurality of corresponding voxels of a plurality of subjects.

14. The atlas of claim **13**, wherein the statistical values calculated from the statistical representation of measured values comprise: a mean and a variance of intensities of each of a plurality of magnetic property values at each corresponding voxel of said plurality of subjects.

15. The atlas of claim **13**, wherein the statistical values are determined for each tissue type.

16. A prior probability MRI based atlas embodied on a computer-readable medium comprising:

- a plurality of nodes, each node configured to store:
 - statistical values calculated from a statistical representation of at least two magnetic property values as determined by magnetic resonance imaging for each of a plurality of corresponding voxels of a plurality of subjects; and
 - at least one tissue type prior probability value corresponding to a tissue type for each of a plurality of corresponding voxels of a plurality of subjects.

17. The atlas of claim **16**, wherein the statistical values calculated from the statistical representation comprise: a mean and a variance of intensities of each of a plurality of magnetic property values at each corresponding voxel of the plurality of subjects.

18. The atlas of claim **17**, wherein the mean and the variance of intensities of the magnetic property values at each corresponding voxel are determined for the tissue type for each of the plurality of corresponding voxels of the plurality of subjects.

19. The atlas of claim **16**, wherein the statistical values calculated from the statistical representation of at least two magnetic property values are scanner-specific.

20. The atlas of claim **16**, wherein the statistical values calculated from the statistical representation of at least two magnetic property values are acquisition-specific.

21. The atlas of claim **16**, wherein the statistical values calculated from the statistical representation of at least two magnetic property values comprise magnetic resonance sequence parameters.

22. A prior probability MRI based atlas embodied on a computer-readable medium comprising:

- a plurality of nodes corresponding to a plurality of voxels of at least one subject; wherein at least one node of the plurality of nodes is configured to store:
 - a prior probability of a tissue type located at a voxel corresponding to the at least one node, calculated for a plurality of tissue types; and
 - a statistical value of a measured magnetic property of the voxel, calculated for each tissue type located at the voxel.

23. The atlas of claim **21**, in which in said statistical value comprises a mean and a variance of the measured magnetic property.

24. The atlas of claim **21**, wherein the plurality of tissue types comprise a labeled anatomical structure.

* * * * *