

(19) World Intellectual Property Organization
International Bureau



(43) International Publication Date
2 February 2012 (02.02.2012)

PCT

(10) International Publication Number
WO 2012/015132 A1

- (51) International Patent Classification:
F27B 14/04 (2006.01) *B01J 3/03* (2006.01)
F27B 14/10 (2006.01)
- (21) International Application Number:
PCT/KR2011/000682
- (22) International Filing Date:
1 February 2011 (01.02.2011)
- (25) Filing Language: English
- (26) Publication Language: English
- (30) Priority Data:
10-2010-0074423 30 July 2010 (30.07.2010) KR
10-2010-0108913 3 November 2010 (03.11.2010) KR
- (71) Applicant (for all designated States except US): **LG INNOTEK CO., LTD.** [KR/KR]; Seoul Square, 541, Namdaemunno 5-ga, Jung-gu, Seoul 100-714 (KR).
- (72) Inventors; and
(75) Inventors/Applicants (for US only): **KIM, Byung Sook** [KR/KR]; Seoul Square, 541, Namdaemunno 5-ga, Jung-gu, Seoul 100-714 (KR). **KIM, Min Sung** [KR/KR]; Seoul Square, 541, Namdaemunno 5-ga, Jung-gu, Seoul 100-714 (KR). **CHAI, Kyoung Hoon** [KR/KR]; Seoul Square, 541, Namdaemunno 5-ga, Jung-gu, Seoul 100-714 (KR).
- (74) Agent: **SEO, Kyo Jun**; 9th Fl. Hyun Juk Bldg., 832-41, Yeoksam-dong, Gangnam-gu, Seoul 135-080 (KR).
- (81) Designated States (unless otherwise indicated, for every kind of national protection available): AE, AG, AL, AM, AO, AT, AU, AZ, BA, BB, BG, BH, BR, BW, BY, BZ, CA, CH, CL, CN, CO, CR, CU, CZ, DE, DK, DM, DO, DZ, EC, EE, EG, ES, FI, GB, GD, GE, GH, GM, GT, HN, HR, HU, ID, IL, IN, IS, JP, KE, KG, KM, KN, KP, KZ, LA, LC, LK, LR, LS, LT, LU, LY, MA, MD, ME, MG, MK, MN, MW, MX, MY, MZ, NA, NG, NI, NO,

[Continued on next page]

(54) Title: HEAT TREATMENT CONTAINER FOR VACUUM HEAT TREATMENT APPARATUS

[Fig. 1]

100

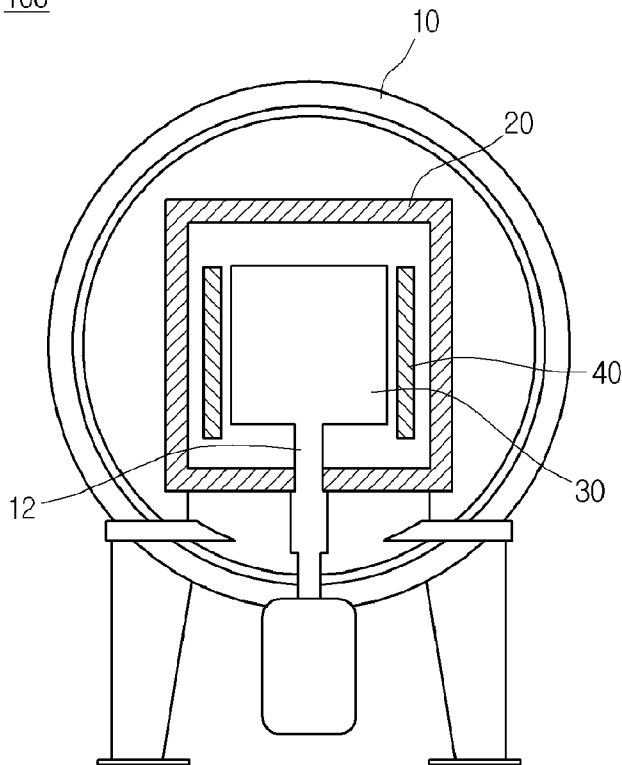

(57) Abstract: A heat treatment container for a vacuum heat treatment apparatus according to an exemplary embodiment includes a bottom portion and a sidewall, and a support protruding inward.

WO 2012/015132 A1

NZ, OM, PE, PG, PH, PL, PT, RO, RS, RU, SC, SD, SE, SG, SK, SL, SM, ST, SV, SY, TH, TJ, TM, TN, TR, TT, TZ, UA, UG, US, UZ, VC, VN, ZA, ZM, ZW.

SM, TR), OAPI (BF, BJ, CF, CG, CI, CM, GA, GN, GQ, GW, ML, MR, NE, SN, TD, TG).

(84) Designated States (*unless otherwise indicated, for every kind of regional protection available*): ARIPO (BW, GH, GM, KE, LR, LS, MW, MZ, NA, SD, SL, SZ, TZ, UG, ZM, ZW), Eurasian (AM, AZ, BY, KG, KZ, MD, RU, TJ, TM), European (AL, AT, BE, BG, CH, CY, CZ, DE, DK, EE, ES, FI, FR, GB, GR, HR, HU, IE, IS, IT, LT, LU, LV, MC, MK, MT, NL, NO, PL, PT, RO, RS, SE, SI, SK,

Published:

- with international search report (*Art. 21(3)*)
- before the expiration of the time limit for amending the claims and to be republished in the event of receipt of amendments (*Rule 48.2(h)*)

Description

Title of Invention: HEAT TREATMENT CONTAINER FOR VACUUM HEAT TREATMENT APPARATUS

Technical Field

- [1] The disclosure relates to a heat treatment container for a vacuum heat treatment apparatus.

Background Art

- [2] A vacuum heat treatment apparatus, as an apparatus of manufacturing a desired material by heat-treating a raw material in a crucible, has an advantage of preventing pollution from the surroundings from generating by performing a heat treatment in a vacuum state. In the vacuum heat treatment apparatus, an insulating member is positioned in a chamber maintained in the vacuum state and a heat is positioned in the insulating member so as to heat the raw material.
- [3] However, a material generated by reacting with the crucible and the raw material during the reaction may be attached on an inner wall of the crucible. Since the generated material is different from the crucible, a heat stress is applied to the crucible due to a difference of heat expansion coefficients between different materials. In a serious case, the crucible may be broken by the heat stress during the reaction. Accordingly, a replacement cost of the crucible is extremely generated, such that productivity may be deteriorated.

Disclosure of Invention

Technical Problem

- [4] The present invention has been made in an effort to provide a heat treatment container for a vacuum heat treatment apparatus capable of preventing breakage due to a heat stress.

Solution to Problem

- [5] An exemplary embodiment of the present invention provides a heat treatment container for a vacuum heat treatment apparatus including: a bottom portion and a sidewall, and a support protruding inward.
- [6] The support may elongate in a depth direction of the heat treatment container.
- [7] The support may be positioned the sidewall.
- [8] The support may be formed at each sidewall by a single or in plural.
- [9] The support may have a rectangular or round cross-section.
- [10] The support may be integrally formed to the heat treatment container.
- [11] The heat treatment container may be for manufacturing of silicon carbide.
- [12] Another exemplary embodiment of the present invention provides a heat treatment

container for a vacuum heat treatment apparatus including a plan shape having a curve-shaped portion.

[13] The plan shape of the heat treatment container may be curved.

[14] The plan shape of the heat treatment container may be circular or ellipse.

[15] The heat treatment container may have a inner space and an opened one side, and may further include a cover member covering the heat treatment container, wherein the cover member may include a first portion having a first thickness and contacting the heat treatment container and a second portion having a second thickness larger than the first thickness and corresponding to the inner space.

[16] A side of the second portion adjacent to the first portion may be inclined or rounded with respect to a cover surface of the cover member.

[17] An exhaust passage may be formed at an adjacent portion to the cover member in the heat treatment container.

[18] The heat treatment container may be for manufacturing of silicon carbide.

Advantageous Effects of Invention

[19] According to an exemplary embodiment, the vacuum heat treatment apparatus can prevent the heat treatment container form being modified due to the heat stress at a high temperature by forming a support in the heat treatment container. In this case, the support is formed to elongate in a depth direction of the heat treatment container, to thereby making it possible to prevent efficiently the modification of the heat treatment container.

[20] The vacuum heat treatment apparatus can prevent the modification and the breakage of the heat treatment container by optimizing a shape of the heat treatment container to minimize the heat stress applied to the heat treatment container. Further, the vacuum heat treatment apparatus can prevent breakage due to a collision between a container part and a cover member by optimizing a shape of the cover member.

Brief Description of Drawings

[21] FIG. 1 is a schematic diagram of a vacuum heat treatment apparatus according to an exemplary embodiment;

[22] FIG. 2 is a perspective view of a heat treatment container part of a vacuum heat treatment apparatus according to a first exemplary embodiment;

[23] FIG. 3 is a cross-sectional view illustrating a part of the heat treatment container part taken along line III-III of FIG. 2;

[24] FIG. 4 is a cross-sectional view illustrating a part of a heat treatment container part according to a first modified example of the first exemplary embodiment;

[25] FIG. 5 is a cross-sectional view illustrating a part of a heat treatment container part according to a second modified example of the first exemplary embodiment;

- [26] FIG. 6 is a cross-sectional view illustrating a part of a heat treatment container part according to a third modified example of the first exemplary embodiment;
- [27] FIG. 7 is a cross-sectional view illustrating a part of a heat treatment container part according to a fourth modified example of the first exemplary embodiment;
- [28] FIG. 8 is a cross-sectional view illustrating a part of a heat treatment container part according to a fifth modified example of the first exemplary embodiment;
- [29] FIG. 9 is a schematic cross-sectional view illustrating a heat treatment container part according to a sixth modified example of the first exemplary embodiment;
- [30] FIG. 10 is a perspective view of a heat treatment container part of a vacuum heat treatment apparatus according to a second exemplary embodiment;
- [31] FIG. 11 is a cross-sectional view taken along line X-X of FIG. 10;
- [32] FIG. 12 is a cross-sectional view illustrating a heat treatment container part according to a first modified example of the second exemplary embodiment; and
- [33] FIG. 13 is a cross-sectional view illustrating a heat treatment container part according to a second modified example of the second exemplary embodiment.

Best Mode for Carrying out the Invention

- [34] In describing embodiments, it will be understood that when layers (films), regions, patterns, or structures are referred to as being "on" or "under" a substrate, layers (films), regions, pads, or patterns, "on" and "under" include "directly" or "indirectly".
- [35] In the drawings, since the thicknesses or sizes of layers (films), regions, patterns, or structures may be modified for clear description, their actual sizes are not fully reflected.
- [36] Hereinafter, an exemplary embodiment of the present invention will be described in detail with reference to accompanying drawings.
- [37] FIG. 1 is a schematic diagram of a vacuum heat treatment apparatus according to an exemplary embodiment.
- [38] Referring to FIG. 1, a vacuum heat treatment apparatus 100 according to the exemplary embodiment includes a chamber 10, an insulating member 20 positioned in the chamber 10, a heat treatment container part 30 and a heating member 40 positioned in the insulating member 20. Hereinafter, a detailed description thereof will be as follows.
- [39] An atmosphere gas is injected into the chamber 10 through an atmosphere gas supplying pipe (not shown). The atmosphere gas may use an inert gas such as argon (Ar), helium (He), or the like.
- [40] The insulating member 20 in the chamber 10 insulates the heat treatment container part 30 so as to maintain at a proper temperature for the reaction. The insulating member 20 may include graphite so as to withstand a high temperature.

- [41] The heat treatment container part 30, in which raw materials are filled and a desired material is generated by reacting with the raw materials, is positioned in the insulating member 20. The heat treatment container part 30 may include graphite so as to withstand a high temperature. The gas generated during the reaction or a non-reacted gas may be discharged through an outlet 12 connected to the heat treatment container part 30.
- [42] The heating member 40 heating the heat treatment container part 30 is positioned between the insulating member 20 and the heat treatment container part 30. The heating member 40 may supply the heat to the heat treatment container part 30 by various methods. For example, the heating member 40 may generate the heat by apply voltage to graphite.
- [43] The heat treatment container part 30 of the vacuum heat treatment apparatus 100 is a crucible which contains the raw material and applies the heat to manufacture the desired material and it will be described below with reference to FIGS. 2 and 3.
- [44] The vacuum heat treatment apparatus 100 may be used as, for example, a manufacturing apparatus of silicon carbide in which silicon carbide is manufactured by heating a mixed raw material including a carbon source and a silicon source.
- [45] That is, the mixed raw material including the carbon source and the silicon source is contained in the heat treatment container part 30 of the vacuum heat treatment apparatus 100 and heated together by the heating member 40.
- [46] In the exemplary embodiment, the silicon source may include various materials capable of supplying silicon. For example, the silicon source may include silica. The silicon source may be a silica power, a silica sol, a silica gel, a quartz powder, or the like. However, the exemplary embodiment is not limited thereto and an organic silicon compound including silicon may be used as the silicon source.
- [47] The carbon source may include a solid carbon source or an organic carbon compound.
- [48] The solid carbon source may be graphite, carbon black, carbon nano tube (CNT), fullerene (C_{60}), or the like.
- [49] The organic carbon compound may be penol, franc, xylene, polyimide, polyurethane, polyvinyl alcohol, polyacrylonitrile, poly vinyl acetate, or the like. In addition, the organic carbon compound may be cellulose, sugar, pitch, tar, or the like.
- [50] The silicon source and the carbon source are mixed.
- [51] Further, when the organic carbon compound is used as the carbon source, it is required to use approximately two times more carbon source than the solid carbon source. However, it may have a little difference depending on the carbon amount generated in the carbonization process. When the organic carbon compound is used as the carbon source, the carbon source in the mixed material is carbonized by heating the

mixed material of the silicon source and the carbon source. The carbonization is preferably maintained at a temperature of 700°C to 1200°C, more preferably, 900°C to 1100°C. However, in the case where the carbon source is not the organic carbon compound, the carbonization may be omitted.

[52] Thereafter, when the mixed material of the carbon source and the silicon source is contained and heated in the heat treatment container part 30, the silicon carbide is manufactured by a carbothermal reaction according to the following reaction formula 1 to 3.

[53] [Reaction Formula 1]

[54] $\text{SiO}_2(\text{s}) + \text{C}(\text{s}) \rightarrow \text{SiO}(\text{g}) + \text{CO}(\text{g})$

[55] [Reaction Formula 2]

[56] $\text{SiO}(\text{g}) + 2\text{C}(\text{s}) \rightarrow \text{SiC}(\text{s}) + \text{CO}(\text{g})$

[57] [Reaction Formula 3]

[58] $\text{SiO}_2(\text{s}) + 3\text{C}(\text{s}) \rightarrow \text{SiC}(\text{s}) + 2\text{CO}(\text{g})$

[59] The heating may be performed in the argon (Ar) or vacuum atmosphere. The degree of a vacuum may be more than 0.03torr to 0.5torr or less, preferably, more than 0.03torr to 0.1torr or less. In the case of the degree of a vacuum of 0.03torr or less, since a mechanical load is mostly generated in the mass-produced equipment, additional equipment is required, such that maintenance of the equipment is difficult and the cost is increased.

[60] The heating temperature may be 1300°C to 1900°C, preferably, 1600°C to 1900°C. Here, the heating time may be about 3 hours, but is not limited thereto.

[61] As such, the vacuum heat treatment apparatus 100 according to the exemplary embodiment may be used for manufacturing silicon carbide, but is not limited thereto. The vacuum heat treatment apparatus 100 may be used for manufacturing various materials in which the heat treatment is required in the synthesis.

[62] Referring to FIGS. 2 and 3, the heat treatment container part of the vacuum heat treatment apparatus according to the first exemplary embodiment will be described in more detail. FIG. 2 is a perspective view of a heat treatment container part of a vacuum heat treatment apparatus according to a first exemplary embodiment and FIG. 3 is a cross-sectional view illustrating a part of the heat treatment container part taken along line III-III of FIG. 2.

[63] Referring to FIGS. 2 and 3, the heat treatment container part 30 has an inner space and may include a heat treatment container 150 having a opened one side, a cover member 130 covering the heat treatment container 150. The heat treatment container part 30 may be made of a material capable of withstanding at a high temperature, for example, graphite.

[64] The heat treatment container 150 includes a bottom and a sidewall which are in-

tegrally formed and has a space portion filled by the raw material. In addition, referring to FIG. 2, a support 152 protruding toward the inside is formed at the inner wall of the heat treatment container 150. The support 152 can prevent the heat treatment container 150 from being modified by the heat stress at a high temperature.

[65] The vacuum heat treatment apparatus used as an apparatus of manufacturing silicon carbide will be described as an example. The carbon source and the silicon source are filled in the heat treatment container 150 and then silicon carbide is generated by the reaction at the high temperature. In this case, since the heat treatment container 150 is made of graphite in order to withstand the high temperature, a silicon carbide layer may be formed in the heat treatment container 150 by reacting with graphite of the heat treatment container 150 and the silicon source. Thereafter, since the silicon carbide layer which is a different material is formed in the heat treatment container 150 made of graphite, a middle portion C of the heat treatment container 150 may be curved toward the outside as compared with the peripheral portion.

[66] In the exemplary embodiment, since the support 152 capable of keeping a curved force is formed at the sidewall of the heat treatment container 150, the modification of the heat treatment container 150 can be prevented.

[67] The support 152 is formed in the inner wall of the heat treatment container 150 as shown in the drawing, but the exemplary embodiment is not limited thereto. Accordingly, the support 152 may be formed at the outer wall of the heat treatment container 150.

[68] The support 152 may elongate in a depth direction of the heat treatment container 150. Accordingly, the modification of the heat treatment container 150 can be prevented.

[69] Referring to FIG. 3, the support 152 may have a rectangular cross-section. However, the exemplary embodiment is not limited thereto. That is, as shown in FIG. 4, a support 154 may have a trapezoidal cross-section. In addition, as shown in FIG. 5, an edge portion R of the cross-section of the support 154 may be rounded. As shown in FIG. 6, a support 158 has in a convex shape and may be entirely rounded. The supports 152, 154, 156, and 158 may have various cross-sectional shapes.

[70] Referring back to FIG. 3, since the support 152 is formed integrally with the heat treatment container 150, a bonding characteristic with the heat treatment container 150 is excellent such that it is possible to efficiently prevent the heat treatment container 150 from being curved. However, the exemplary embodiment is not limited thereto. That is, as shown in FIG. 7, a support 160 is separated from the heat treatment container 150 to be attached to the heat treatment container 150.

[71] Referring back to FIG. 2, the support 152 may be separately formed at each sidewall of the heat treatment container 150. The support 152 may be positioned at the middle

portion C of the heat treatment container 150. However, the exemplary embodiment is not limited thereto. That is, as shown in FIG. 8, a support 162 may be plurally formed at each sidewall of the heat treatment container 150. At this time, the supports 162 formed plurally at one sidewall may be separated from each other at a predetermined interval.

[72] Further, in a modified example as shown in FIG. 9, a plurality of heat treatment container parts 30 including the heat treatment container 150 and the cover member 130 are stacked and an outer member 310 may surround the outside thereto. The support (not shown) may be also formed at the outer member 310, but it also belongs to the scope of the exemplary embodiment.

[73] Hereinafter, a heat treatment container part according to another exemplary embodiment of the present invention will be described with reference to FIG. 10 to 13. The same components as the described embodiment are omitted in detail and different components will be described in detail.

[74] FIG. 10 is a perspective view of a heat treatment container part of a vacuum heat treatment apparatus according to a second exemplary embodiment and FIG. 11 is a cross-sectional view taken along line X-X of FIG. 10.

[75] Referring to FIGS. 10 and 11, a plan shape of the heat treatment container part 30 has a curve-shaped portion to prevent the heat treatment container part 30 from being damaged. The vacuum heat treatment apparatus is used, for example, as an apparatus of silicon carbide.

[76] The carbon source and the silicon source are filled in the heat treatment container part 30 and silicon carbide is generated by the reaction at a high temperature. At this time, the heat treatment container part 30 is made of graphite in order to the high temperature in order to withstand the high temperature, a silicon carbide layer may be formed in the heat treatment container part 30 by reacting with graphite of the heat treatment container part 30 and the silicon source. Accordingly, the silicon carbide layer which is different material may be formed in the heat treatment container part 30 made of graphite. Since a heat expansion coefficient of silicon carbide is larger than that of graphite constituting the heat treatment container part 30 in the related art, the middle portion of the heat treatment container part 30 is expanded. However, in the exemplary embodiment, since the plan shape of the heat treatment container part 30 has the curve-shaped portion, a force applied to the heat treatment container part 30 can be minimized by using directivity between the heat stresses applied to the heat treatment container part 30. Accordingly, the modification and the breakage of the heat treatment container can be prevented.

[77] At this time, since the plan shape of the heat treatment container part 30 is curved, the force applied to the heat treatment container part 30 may be close to almost zero.

For example, the plan shape of the heat treatment container part 30 may be circular or ellipse.

[78] In the exemplary embodiment, the heat treatment container part 30 has an inner space and may include heat treatment container 32 having an opened one side and a cover member 34 covering the heat treatment container 32.

[79] The heat treatment container 32 includes an inner space filled with the raw material for the reaction. In addition, an exhaust passage 322 is formed in the heat treatment container 32 so that a gas flows between the cover member 34 and the heat treatment container 32. The gases generated in the heat treatment may be discharged through the exhaust passage 322. The exhaust passage 322 may be formed in the heat treatment container of the first exemplary embodiment (reference numeral 150 of FIG. 2).

[80] The cover member 34 may include a first portion 341 formed at the outer area so as to contact the heat treatment container 32 and a second portion 342 formed at the central area so as to correspond to the space of the heat treatment container 32. At this time, a second thickness T2 of the second portion 342 is larger than a first thickness T1 of the first portion 341 such that the heat treatment container 32 and the cover member 34 can be firmly fixed.

[81] A side 343 of the second portion 342 adjacent to the first portion 341 is inclined with respect to a cover surface of the cover member 34. As such, since the side 343 is inclined, the breakage due to the collision of the heat treatment container 32 and the cover member 34 can be efficiently prevented. The side 343 of the second portion 342 may have various shapes and for example, as shown in FIGS. 12 and 13, sides 344 and 345 may include a round portion.

[82] The cover member 34 may be applied to the first exemplary embodiment described above. In addition, in the exemplary embodiment, as shown in FIG. 5, the plurality of the heat treatment container part 34 including the heat treatment container 32 and the cover member 34 are stacked, the outside can be covered by the outer member (hereinafter, reference numeral 310 of FIG. 5). The cover member of the outer member 310 may include the first portion and the second portion and it also belongs to the scope of the present invention.

[83] The features, structures, effects, and the like described in the exemplary embodiments are included in at least one exemplary embodiment and are not particularly limited to only one exemplary embodiment. Furthermore, the features, structures, effects, and the like described in the exemplary embodiments can be applied to other exemplary embodiments through combination and modification by those skilled in the art to which the exemplary embodiments belong. Therefore, it should be appreciated that contents related with the combination and modification are included in the scope of the present invention.

[84] As described above, the preferred embodiments have been described and illustrated in the drawings and the specification. Herein, specific terms have been used, but are just used for the purpose of describing the present invention and are not used for defining the meaning or limiting the scope of the present invention, which is disclosed in the appended claims. Therefore, it will be appreciated to those skilled in the art that various modifications are made and other equivalent embodiments are available. Accordingly, the actual technical protection scope of the present invention must be determined by the spirit of the appended claims.

Claims

- [Claim 1] A heat treatment container for a vacuum heat treatment apparatus, comprising: a bottom portion and a sidewall, and a support protruding inward.
- [Claim 2] The heat treatment container of claim 1, wherein the support elongates in a depth direction of the heat treatment container.
- [Claim 3] The heat treatment container of claim 1, wherein the support is positioned the sidewall.
- [Claim 4] The heat treatment container of claim 3, wherein the support is formed at each sidewall by a single or in plural.
- [Claim 5] The heat treatment container of claim 1, wherein the support has a rectangular or round cross-section.
- [Claim 6] The heat treatment container of claim 1, wherein the support is integrally formed to the heat treatment container.
- [Claim 7] The heat treatment container of claim 1, wherein the heat treatment container is for manufacturing of silicon carbide.
- [Claim 8] A heat treatment container for a vacuum heat treatment apparatus, comprising: a plan shape having a curve-shaped portion.
- [Claim 9] The heat treatment container of claim 8, wherein the plan shape of the heat treatment container is curved.
- [Claim 10] The heat treatment container of claim 8, wherein the plan shape of the heat treatment container is circular or ellipse.
- [Claim 11] The heat treatment container of claim 8, wherein the heat treatment container has a inner space and an opened one side, and further includes a cover member covering the heat treatment container, wherein the cover member includes a first portion having a first thickness and contacting the heat treatment container and a second portion having a second thickness larger than the first thickness and corresponding to the inner space.
- [Claim 12] The heat treatment container of claim 11, wherein a side of the second portion adjacent to the first portion is inclined or rounded with respect to a cover surface of the cover member.
- [Claim 13] The heat treatment container of claim 11, wherein an exhaust passage is formed at an adjacent portion to the cover member in the heat treatment container.
- [Claim 14] The heat treatment container of claim 8, wherein the heat treatment container is for manufacturing of silicon carbide.

[Fig. 1]

100

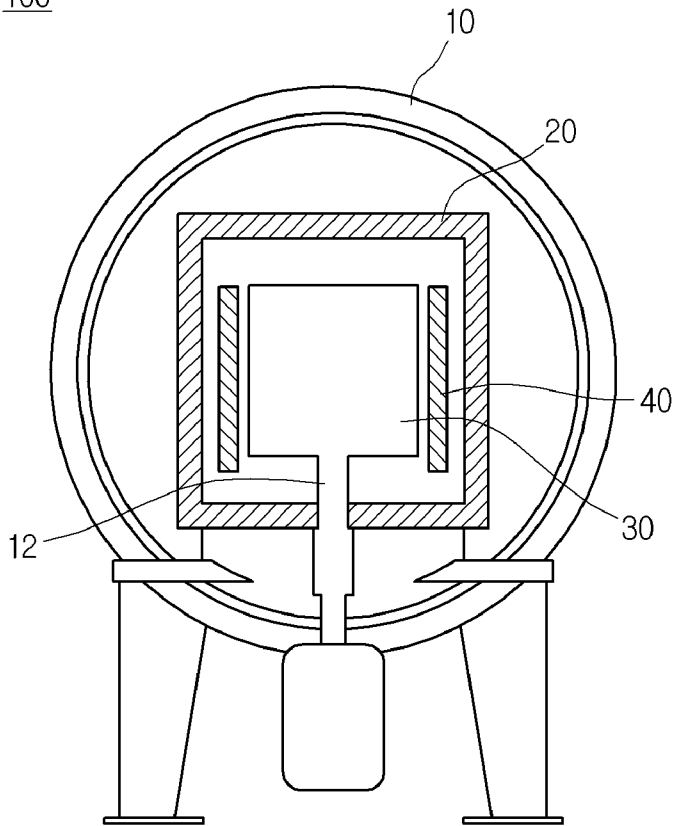

[Fig. 2]

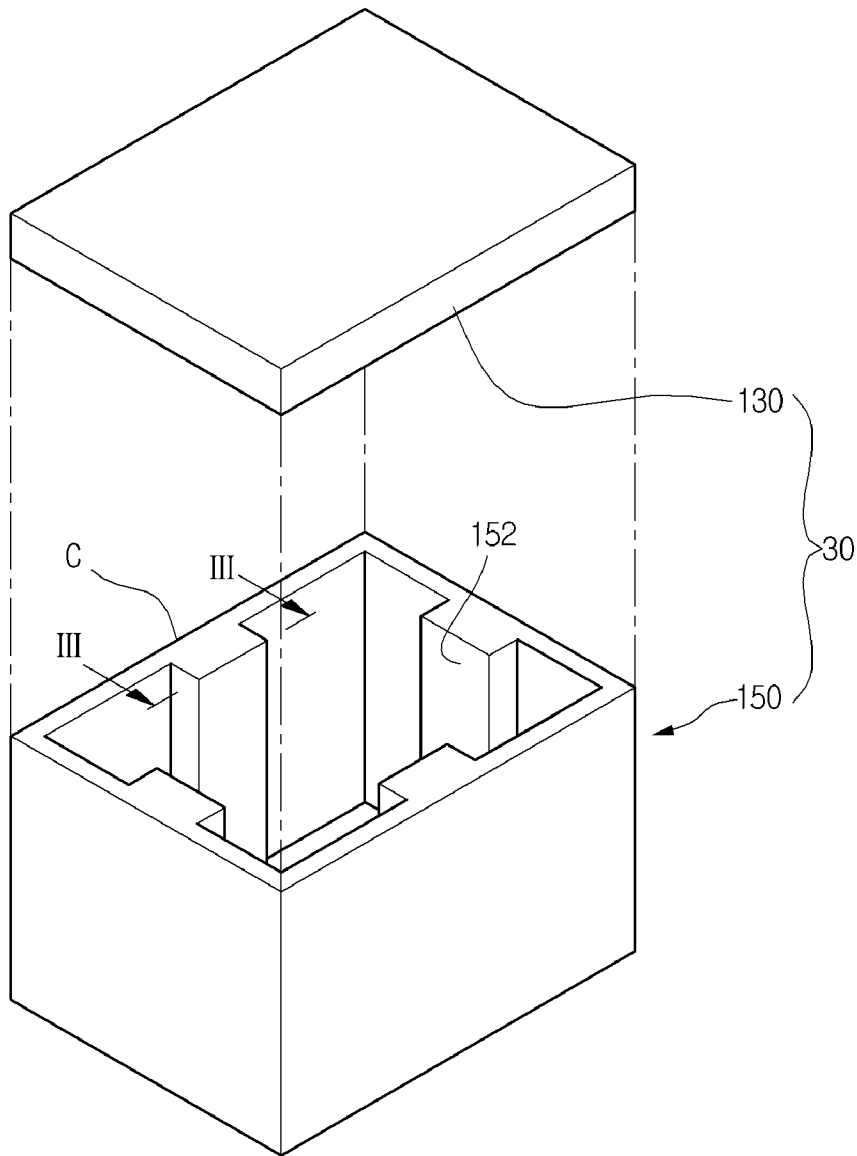

[Fig. 3]

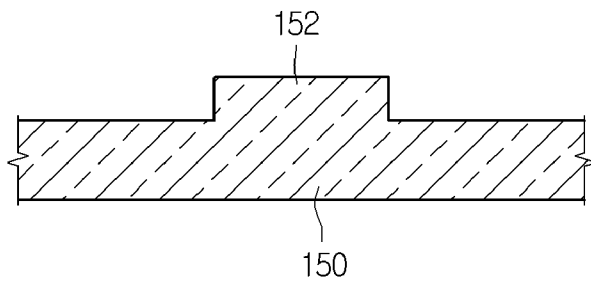

[Fig. 4]

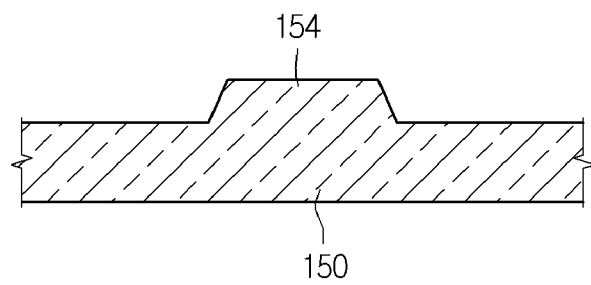

[Fig. 5]

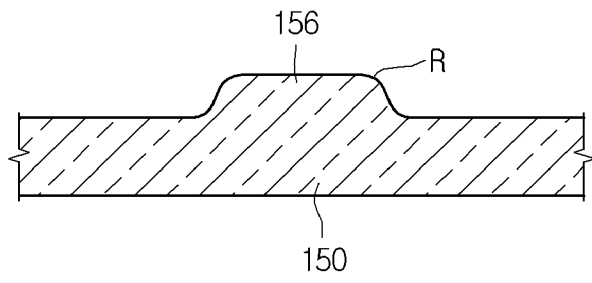

[Fig. 6]

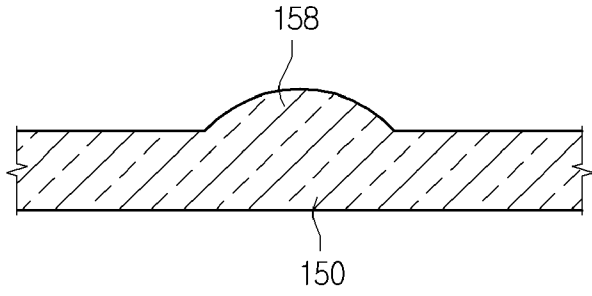

[Fig. 7]

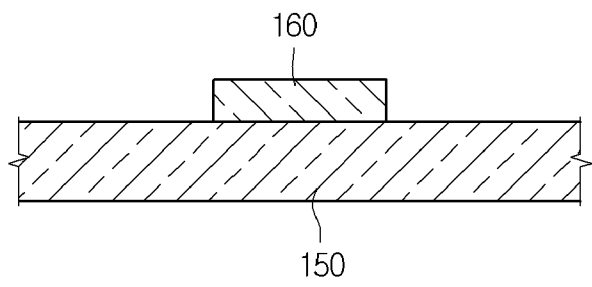

[Fig. 8]

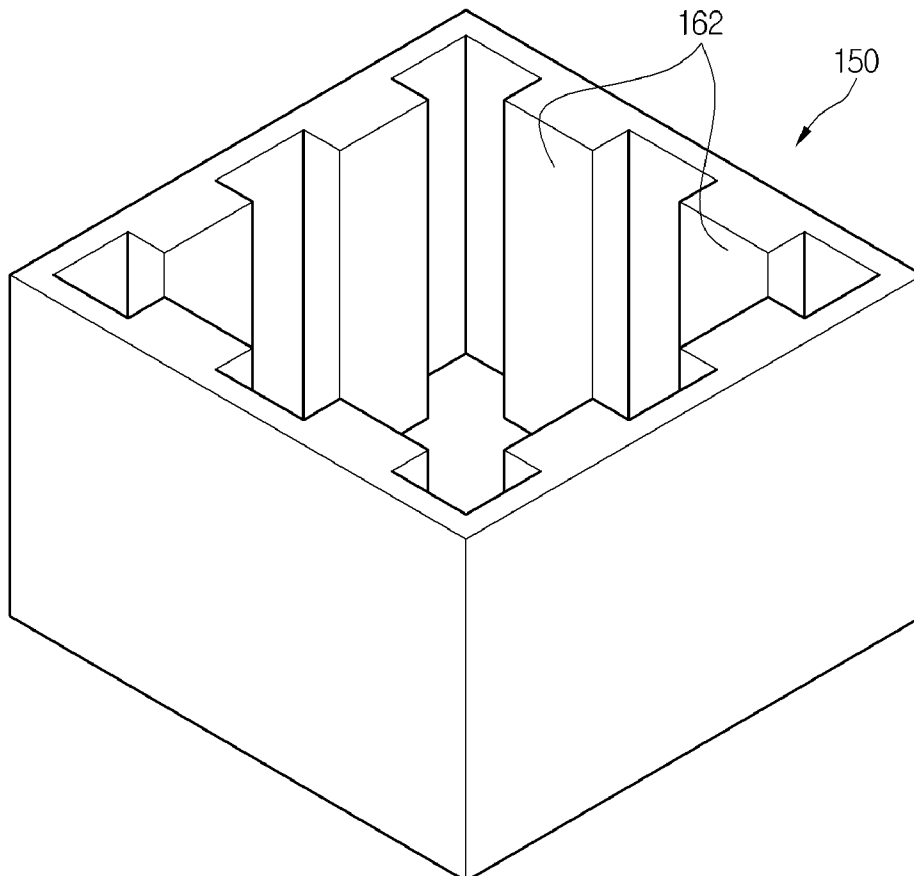

[Fig. 9]

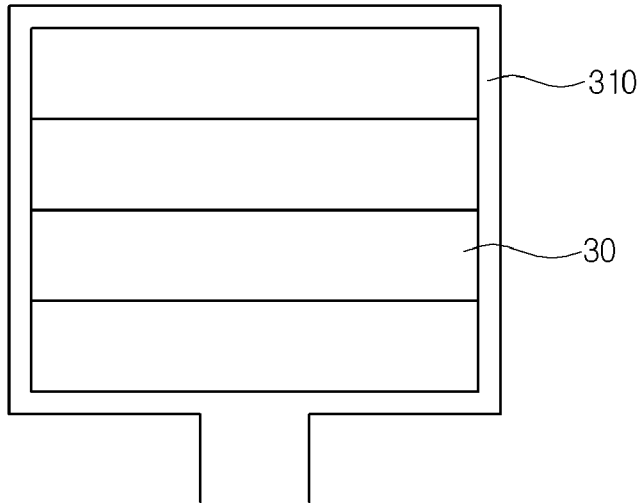

[Fig. 10]

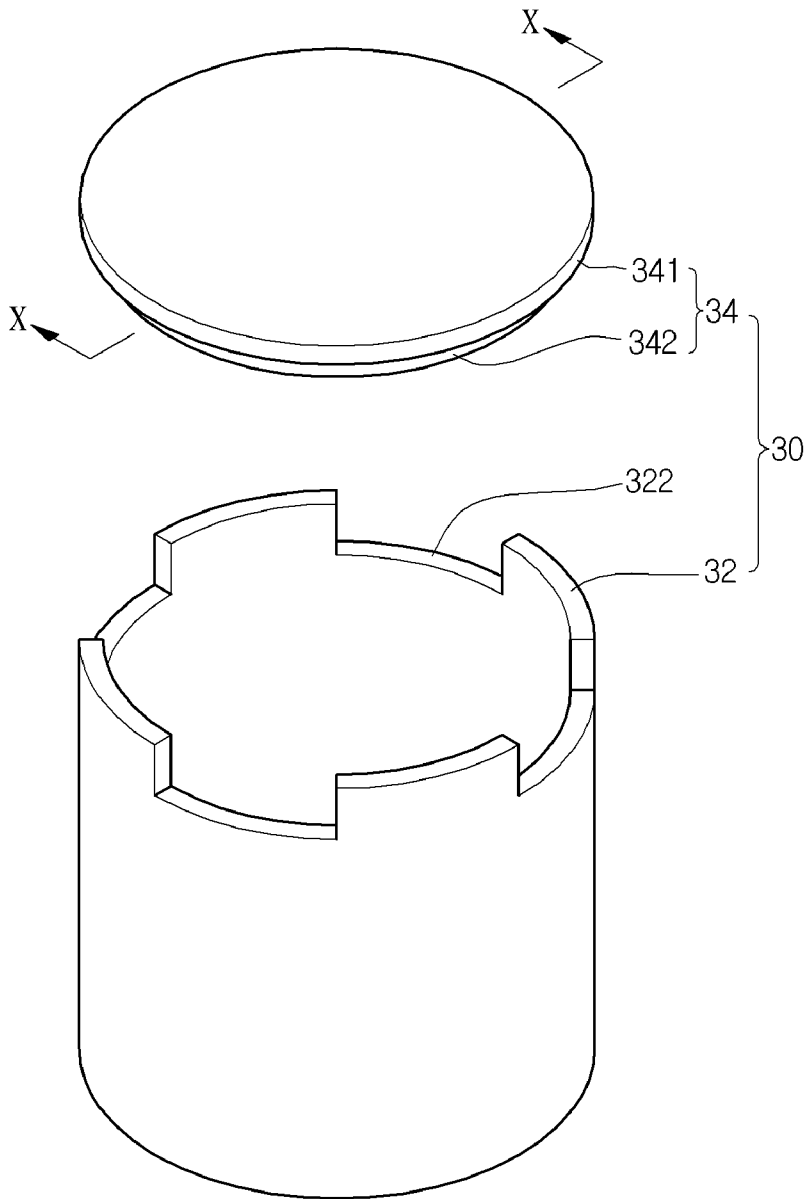

[Fig. 11]

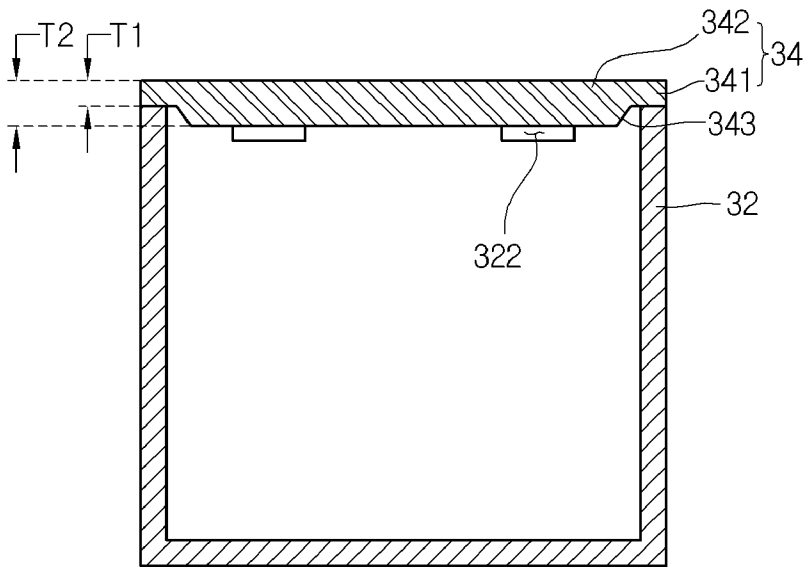

[Fig. 12]

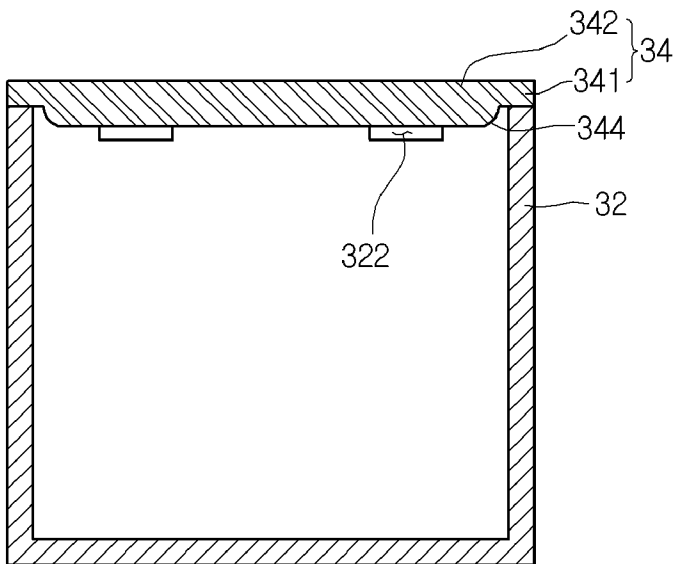

[Fig. 13]

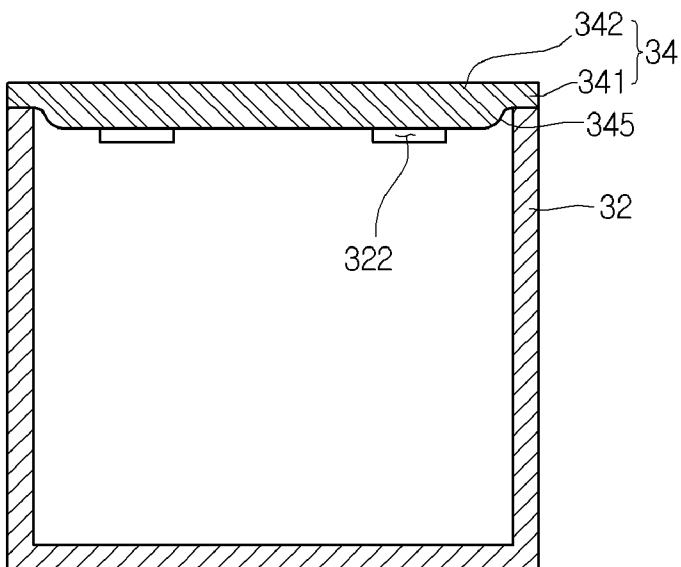

INTERNATIONAL SEARCH REPORT

International application No.
PCT/KR2011/000682**A. CLASSIFICATION OF SUBJECT MATTER***F27B 14/04(2006.01)i, F27B 14/10(2006.01)i, B01J 3/03(2006.01)i*

According to International Patent Classification (IPC) or to both national classification and IPC

B. FIELDS SEARCHED

Minimum documentation searched (classification system followed by classification symbols)

F27B 14/04; C21D 1/773; F16J 15/04; F16L 27/10; C23C 14/32; F16L 59/08; C30B 29/12; F16J 13/06; C30B 11/00; F16L 59/06

Documentation searched other than minimum documentation to the extent that such documents are included in the fields searched

Korean utility models and applications for utility models
Japanese utility models and applications for utility models

Electronic data base consulted during the international search (name of data base and, where practicable, search terms used)

eKOMPASS(KIPO internal) & Keywords: vacuum, container, sidewall, cover

C. DOCUMENTS CONSIDERED TO BE RELEVANT

Category*	Citation of document, with indication, where appropriate, of the relevant passages	Relevant to claim No.
A	JP 07-071690 A (KUBOTA CO.) 17 March 1995 See the abstract, paragraphs [0004]-[0006], and figures 1-6	1-7
A	JP 06-281090 A (KUBOTA CO.) 07 October 1994 See the abstract and figures 1-4	1-7
A	JP 05-302164 A (KOBE STEEL LTD.) 16 November 1993 See the abstract, paragraph [0008], and figures 7-10	1-7
X	JP 60-149714 A (KATO KUNIO) 07 August 1985 See the abstract and figure 2	8-14
X	JP 2003-240121 A (KOKUSAI GIJUTSU KAIHATSU CO., LTD.) 27 August 2003 See the abstract and figures 1-2	8-14
X	JP 2005-035825 A (NIKON CO. et al.) 10 February 2005 See the abstract and figures 1, 5	8-14

 Further documents are listed in the continuation of Box C. See patent family annex.

* Special categories of cited documents:

"A" document defining the general state of the art which is not considered to be of particular relevance

"E" earlier application or patent but published on or after the international filing date

"L" document which may throw doubts on priority claim(s) or which is cited to establish the publication date of citation or other special reason (as specified)

"O" document referring to an oral disclosure, use, exhibition or other means

"P" document published prior to the international filing date but later than the priority date claimed

"T" later document published after the international filing date or priority date and not in conflict with the application but cited to understand the principle or theory underlying the invention

"X" document of particular relevance; the claimed invention cannot be considered novel or cannot be considered to involve an inventive step when the document is taken alone

"Y" document of particular relevance; the claimed invention cannot be considered to involve an inventive step when the document is combined with one or more other such documents, such combination being obvious to a person skilled in the art

"&" document member of the same patent family

Date of the actual completion of the international search

17 NOVEMBER 2011 (17.11.2011)

Date of mailing of the international search report

18 NOVEMBER 2011 (18.11.2011)

Name and mailing address of the ISA/KR

Korean Intellectual Property Office
Government Complex-Daejeon, 189 Cheongsu-ro,
Seo-gu, Daejeon 302-701, Republic of Korea

Facsimile No. 82-42-472-7140

Authorized officer

JUNG Sug Woo

Telephone No. 82-42-481-8443



INTERNATIONAL SEARCH REPORT

International application No.

PCT/KR2011/000682

Box No. II Observations where certain claims were found unsearchable (Continuation of item 2 of first sheet)

This international search report has not been established in respect of certain claims under Article 17(2)(a) for the following reasons:

- 1. Claims Nos.:
because they relate to subject matter not required to be searched by this Authority, namely:

- 2. Claims Nos.:
because they relate to parts of the international application that do not comply with the prescribed requirements to such an extent that no meaningful international search can be carried out, specifically:

- 3. Claims Nos.:
because they are dependent claims and are not drafted in accordance with the second and third sentences of Rule 6.4(a).

Box No. III Observations where unity of invention is lacking (Continuation of item 3 of first sheet)

This International Searching Authority found multiple inventions in this international application, as follows:

- I. Claims 1-7 directed to a heat treatment container for a vacuum heat treatment apparatus, comprising: a bottom portion and a sidewall, and a support protruding inward.
- II. Claims 8-14 directed to a heat treatment container for a vacuum heat treatment apparatus, comprising: a plan shape having a curve-shaped portion.

- 1. As all required additional search fees were timely paid by the applicant, this international search report covers all searchable claims.
- 2. As all searchable claims could be searched without effort justifying an additional fee, this Authority did not invite payment of any additional fee.
- 3. As only some of the required additional search fees were timely paid by the applicant, this international search report covers only those claims for which fees were paid, specifically claims Nos.:

- 4. No required additional search fees were timely paid by the applicant. Consequently, this international search report is restricted to the invention first mentioned in the claims; it is covered by claims Nos.:

- Remark on Protest**
- The additional search fees were accompanied by the applicant's protest and, where applicable, the payment of a protest fee.
 - The additional search fees were accompanied by the applicant's protest but the applicable protest fee was not paid within the time limit specified in the invitation.
 - No protest accompanied the payment of additional search fees.

INTERNATIONAL SEARCH REPORT

Information on patent family members

International application No.

PCT/KR2011/000682

Patent document cited in search report	Publication date	Patent family member(s)	Publication date
JP 07-071690 A	17.03.1995	None	
JP 06-281090 A	07.10.1994	None	
JP 05-302164 A	16.11.1993	JP 2054123 C JP 7091630 B	23.05.1996 04.10.1995
JP 60-149714 A	07.08.1985	JP 1386786 C	14.07.1987
JP 2003-240121 A	27.08.2003	JP 4126644 B2	30.07.2008
JP 2005-035825 A	10.02.2005	None	