

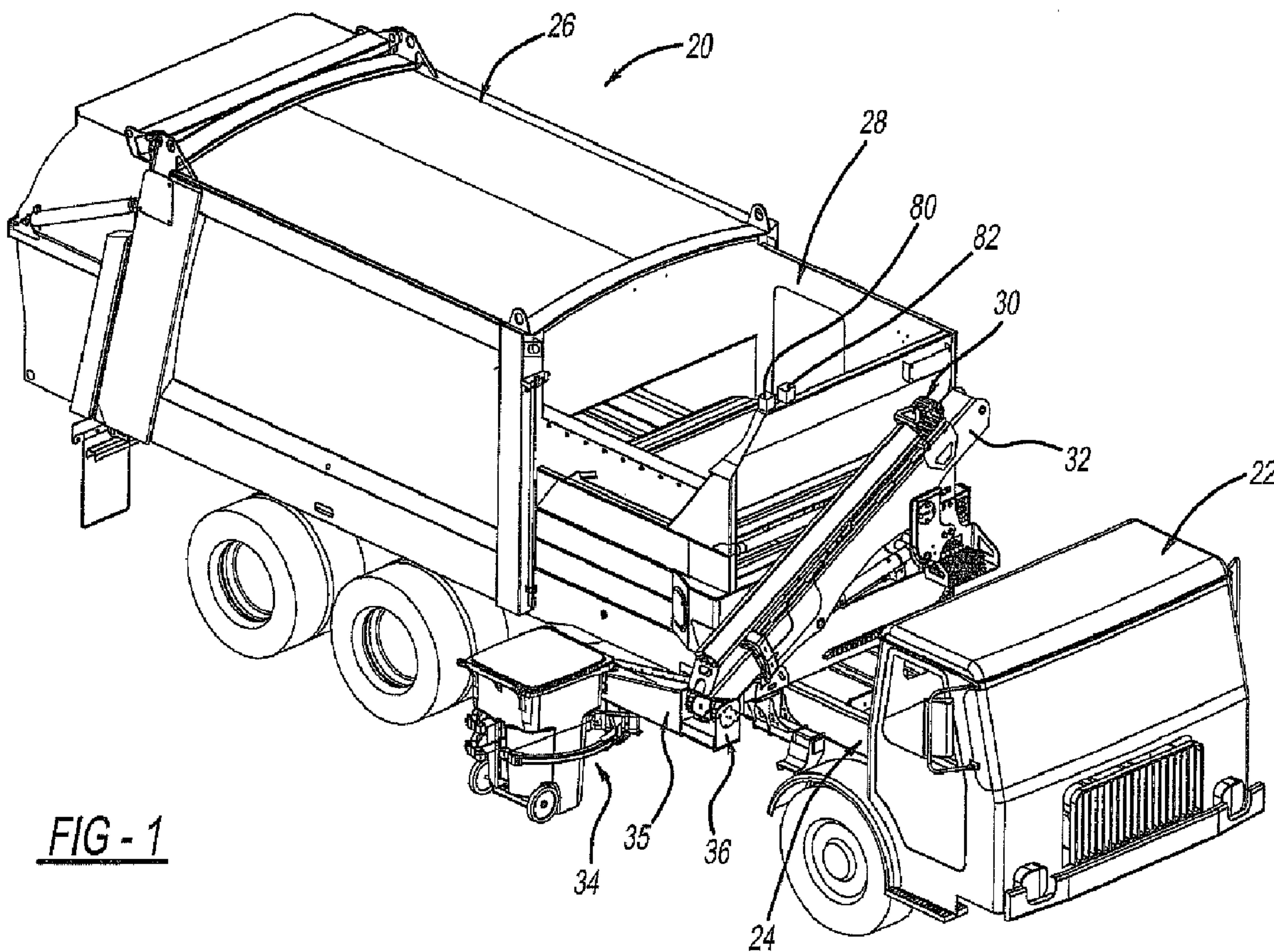

(86) Date de dépôt PCT/PCT Filing Date: 2012/08/09
 (87) Date publication PCT/PCT Publication Date: 2013/02/14
 (85) Entrée phase nationale/National Entry: 2014/01/22
 (86) N° demande PCT/PCT Application No.: US 2012/050084
 (87) N° publication PCT/PCT Publication No.: 2013/023024
 (30) Priorités/Priorities: 2011/08/11 (US61/522,552);
 2012/08/09 (US13/570,504)

(51) Cl.Int./Int.Cl. *B65F 3/04* (2006.01),
B65F 3/08 (2006.01)
 (71) Demandeur/Applicant:
 THE HEIL CO., US
 (72) Inventeurs/Inventors:
 PRICE, THOMAS L., US;
 BARES, JOHN, US;
 DOLL, ROBERT H., US;
 PARKER, BRIAN T., US
 (74) Agent: MACRAE & CO.

(54) Titre : VEHICULE DE RAMASSAGE D'ORDURES AYANT UN BRAS TELESCOPIQUE
 (54) Title: REFUSE COLLECTION VEHICLE WITH TELESCOPING ARM



(57) Abrégé/Abstract:

A refuse collection vehicle has a container collection arm with a telescoping boom coupled with a refuse stowage unit of the vehicle. A grasping mechanism is coupled with an end of the boom. A rotary actuator couples the grasping mechanism with the boom to enable a waste container to be moved between a pick up position and a dump position.

(12) INTERNATIONAL APPLICATION PUBLISHED UNDER THE PATENT COOPERATION TREATY (PCT)

(19) World Intellectual Property
Organization
International Bureau

WIPO | PCT

(10) International Publication Number
WO 2013/023024 A3(43) International Publication Date
14 February 2013 (14.02.2013)

- (51) **International Patent Classification:**
B65F 3/04 (2006.01) *B65F 3/08* (2006.01)
- (21) **International Application Number:**
PCT/US2012/050084
- (22) **International Filing Date:**
9 August 2012 (09.08.2012)
- (25) **Filing Language:** English
- (26) **Publication Language:** English
- (30) **Priority Data:**
61/522,552 11 August 2011 (11.08.2011) US
13/570,504 9 August 2012 (09.08.2012) US
- (71) **Applicant (for all designated States except US):** **THE HEIL CO.** [US/US]; 2030 Hamilton Place Blvd., Suite 200, Chattanooga, Tennessee 37421 (US).
- (72) **Inventors; and**
- (75) **Inventors/Applicants (for US only):** **PRICE, Thomas, L.** [US/US]; 119 Road 920, Mentone, Alabama 35984 (US). **BARES, John** [US/US]; #10 40th Street, Pittsburgh, Pennsylvania 15201 (US). **DOLL, Robert, H.** [US/US]; 5240 Stanton Avenue, Apt. 307, Pittsburgh, Pennsylvania 15201 (US). **PARKER, Brian, T.** [US/US]; 22 Ridgerock Drive, Signal Mountain, Tennessee 37377 (US).
- (74) **Agents:** **TAYLOR, W. R. Duke** et al.; Harness, Dickey & Pierce, P.L.C., P.O. Box 828, Bloomfield Hills, Michigan 48303 (US).
- (81) **Designated States (unless otherwise indicated, for every kind of national protection available):** AE, AG, AL, AM, AO, AT, AU, AZ, BA, BB, BG, BH, BN, BR, BW, BY, BZ, CA, CH, CL, CN, CO, CR, CU, CZ, DE, DK, DM, DO, DZ, EC, EE, EG, ES, FI, GB, GD, GE, GH, GM, GT, HN, HR, HU, ID, IL, IN, IS, JP, KE, KG, KM, KN, KP, KR, KZ, LA, LC, LK, LR, LS, LT, LU, LY, MA, MD, ME, MG, MK, MN, MW, MX, MY, MZ, NA, NG, NI, NO, NZ, OM, PE, PG, PH, PL, PT, QA, RO, RS, RU, RW, SC, SD, SE, SG, SK, SL, SM, ST, SV, SY, TH, TJ, TM, TN, TR, TT, TZ, UA, UG, US, UZ, VC, VN, ZA, ZM, ZW.
- (84) **Designated States (unless otherwise indicated, for every kind of regional protection available):** ARIPO (BW, GH, GM, KE, LR, LS, MW, MZ, NA, RW, SD, SL, SZ, TZ, UG, ZM, ZW), Eurasian (AM, AZ, BY, KG, KZ, RU, TJ, TM), European (AL, AT, BE, BG, CH, CY, CZ, DE, DK, EE, ES, FI, FR, GB, GR, HR, HU, IE, IS, IT, LT, LU, LV, MC, MK, MT, NL, NO, PL, PT, RO, RS, SE, SI, SK, SM, TR), OAPI (BF, BJ, CF, CG, CI, CM, GA, GN, GQ, GW, ML, MR, NE, SN, TD, TG).

Published:

— with international search report (Art. 21(3))

[Continued on next page]

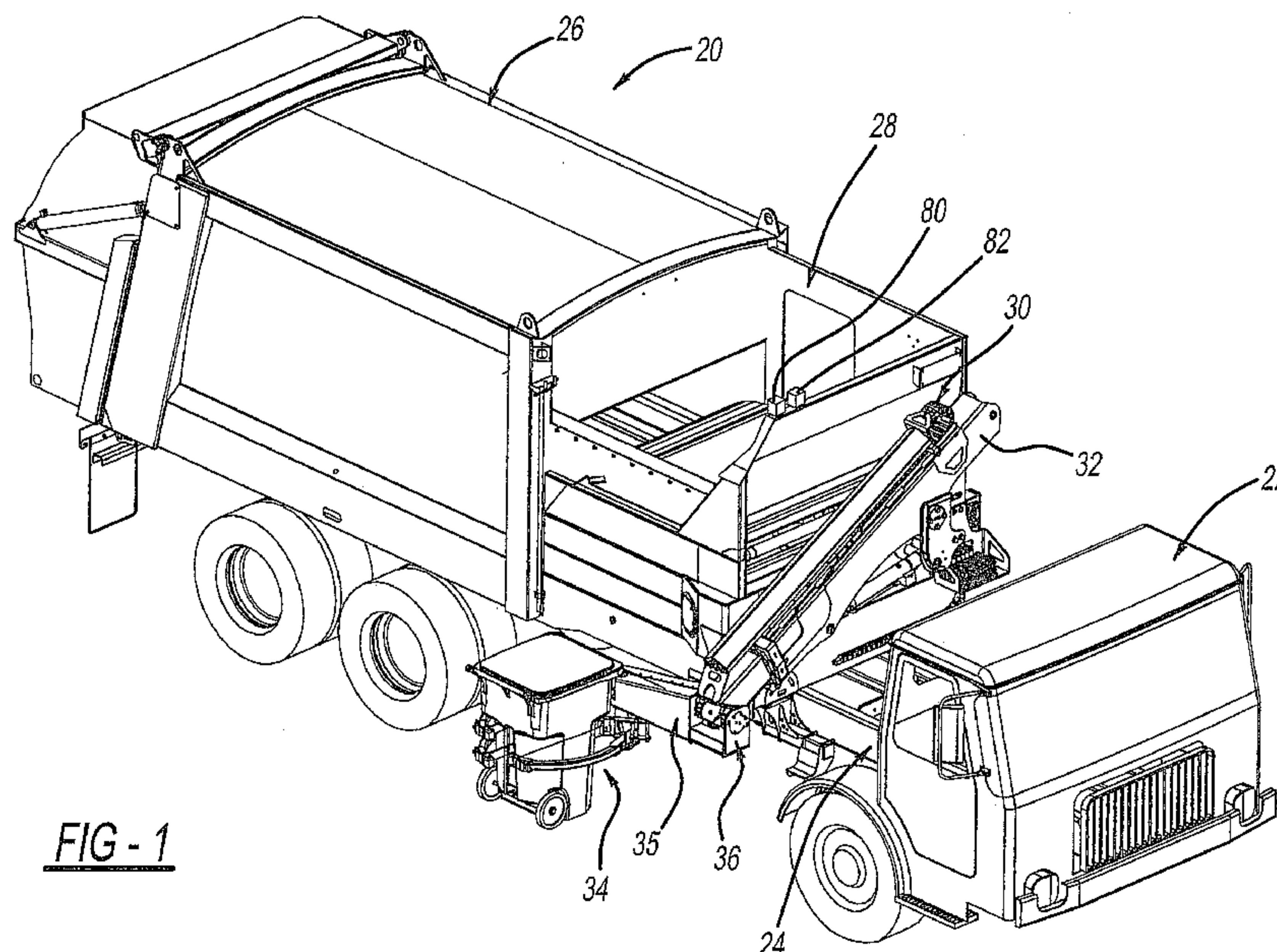
(54) **Title:** REFUSE COLLECTION VEHICLE WITH TELESCOPING ARM**FIG - 1**

(57) **Abstract:** A refuse collection vehicle has a container collection arm with a telescoping boom coupled with a refuse stowage unit of the vehicle. A grasping mechanism is coupled with an end of the boom. A rotary actuator couples the grasping mechanism with the boom to enable a waste container to be moved between a pick up position and a dump position.



WO 2013/023024 A3

WO 2013/023024 A3 

(88) Date of publication of the international search report:
18 April 2013

REFUSE COLLECTION VEHICLE WITH TELESCOPING ARM

CROSS-REFERENCE TO RELATED APPLICATIONS

5 **[0001]** This application claims priority to U.S. Utility Application No. 13/570,504, filed on August 9, 2012 and the benefit of U.S. Provisional Application No. 61/522,552, filed on August 11, 2011. The entire disclosures of the above applications are incorporated herein by reference.

FIELD

10 **[0002]** The present disclosure relates to refuse collection vehicles and, more particularly, to refuse collection vehicles that include a side loading collection arm.

BACKGROUND

15 **[0003]** Various types of refuse collection vehicles exist in the art. These vehicles include numerous types of pick up or collection arms. The collection arms usually move from a pick up position, picking up a garbage can at the curb, to a dump position, dumping the garbage can in a hopper. Ordinarily, these arms include various types of linkages to move the arm from
20 one position to the other. These linkages utilize a number of parts as well as hydraulic cylinders. Due to the movement from one position to the other, the collection arms can be very complicated and include numerous parts. While these arms work satisfactory for their intended purpose, designers strive to improve the art.

25 **[0004]** When these collection arms require significant maintenance, it generally requires the entire collection arm being removed from the vehicle. Thus, this requires significant down time of the vehicle. Also, due to their complexity, the collection arms are substantially heavy and add additional weight to the vehicle.

30 **[0005]** The present disclosure provides the art with a refuse collection vehicle that overcomes the shortcomings of the prior devices. The present disclosure provides the art with a telescoping collection arm that includes a pivot

bearing assembly that enables vertical movement of the collection arm. In addition, the pivot may slide along a track inside the hopper to provide additional horizontal movement of the arm. The pick up arm can be quickly removed from the pivot bearing assembly for replacement or substitution of other like arms.

5 The collection arm includes a dynamic control to alter its vertical and horizontal movements which, in turn, alter the position of the gripping fingers. The collection arm and the bearing assembly are coupled with the vehicle body hopper to enable the collection arm to pivot with respect to the hopper.

10

SUMMARY

[0006] According to the disclosure, a refuse collection vehicle comprises a vehicle with a refuse stowage unit secured to the vehicle. A hopper is coupled with the refuse stowage unit to receive refuse. A collection arm is coupled with the vehicle to grasp containers and empty the containers in the hopper. The collection arm includes a telescoping boom coupled with the refuse stowage unit. A grasping mechanism is coupled with one end of the telescoping boom. The grasping mechanism is adapted to grasp containers. The grasping mechanism includes at least one rotatable actuator that moves the container from a pick up position to an empty position. The grasping mechanism includes at least one moveable finger to couple with the container to enable picking up of the container. The telescoping boom is pivotally secured to the refuse stowage unit. A pivot bearing assembly is coupled with the hopper to receive the telescoping boom. A cylinder is mounted on the hopper and is coupled with the telescoping boom. The cylinder enables movement of the boom in two degrees of freedom. The collection arm is readily removable from the vehicle. The collection arm may be replaced with a collection arm that accomplishes a different function such as the picking up of brush, cutting trees or the like. The collection arm enables pick up of containers above and below the street grade on which the vehicle is traveling.

30

[0007] According to a second object of the disclosure, a collection arm for a refuse vehicle comprises a telescoping boom adapted to be coupled with a refuse stowage unit. A grasping mechanism is coupled with one end of the

telescoping boom. The grasping mechanism is adapted to grasp containers. The grasping mechanism includes at least one rotatable actuator to move the container from a pick up position to an empty position. The grasping mechanism includes at least one moveable finger to couple with the container to enable
5 picking up of the container. The telescoping boom includes a pivot bearing assembly adapted to be pivotally secured to the refuse stowage unit. The pivot bearing assembly is adapted to be coupled with the hopper. A cylinder is coupled with the boom and adapted to be mounted on the hopper. The cylinder enables movement of the boom in two degrees of freedom of motion. The range
10 of motion of the telescoping boom coupled with the rotary actuator assures that the container opening is always parallel with the ground regardless of the grade. The collection arm is readily removable from the vehicle. A different grasping mechanism may be mounted on the collection arm that accomplishes a different function. The collection arm enables pick up of containers above and below the
15 street grade on which the vehicle is traveling.

[0008] Further areas of applicability will become apparent from the description provided herein. The description and specific examples in this summary are intended for purposes of illustration only and are not intended to limit the scope of the present disclosure.

20

DRAWINGS

[0009] The drawings described herein are for illustrative purposes only of selected embodiments and not all possible implementations, and are not intended to limit the scope of the present disclosure.

25 **[0010]** FIG. 1 is a perspective view of a refuse collection vehicle.

[0011] FIG. 2 is an elevation view of the telescoping arm on the refuse stowage unit.

[0012] FIG. 3 is an elevation view like FIG. 2 illustrating a container moving from a pick up position to a dump position.

30 **[0013]** FIG. 4 is a front elevation view of the refuse collection vehicle with the collection arm extended to retrieve a container below the street grade level.

[0014] FIG. 5 is a perspective view of a refuse collection vehicle picking up a container above the street grade level.

[0015] FIG. 6 is a perspective view of the telescoping arm removed from a pivot bearing assembly.

5 **[0016]** FIG. 7 is a perspective view illustrating the cylinder attached to the collection arm.

[0017] FIG. 7a is a view like FIG. 7 of an alternative embodiment of the pivot assembly.

[0018] FIG. 7b is a view like FIG. 7a in an alternate position.

10 **[0019]** FIG. 8 is a perspective view of the refuse collection vehicle with the collection arm in an extended position.

[0020] FIG. 9 is a perspective view of the refuse collection vehicle with the collection arm in a retracted position.

15 **[0021]** FIG. 10 is a view like FIG. 9 of the container being moved towards a dump position.

[0022] FIG. 11 is a perspective view of the refuse collection vehicle with the collection arm in a dump position.

[0023] FIG. 12 is an elevation view of the grasping mechanism in a retracted position.

20 **[0024]** FIG. 13 is a perspective view of the grasping mechanism in a retracted position.

[0025] FIG. 14 is a perspective view of an additional embodiment of the refuse collection vehicle.

25 **[0026]** FIG. 15 is an elevation view of the collection arm of FIG. 14 moving between a pick up and a dump position.

[0027] FIG. 16 is a perspective view of an additional embodiment of the refuse collection vehicle present invention with the collection arm in an extended position.

30 **[0028]** FIG. 17 is a perspective view of the refuse collection vehicle of FIG. 16 with the collection arm in a dump position.

DETAILED DESCRIPTION

[0029] Turning to the drawings, a refuse collection vehicle is illustrated and designated with the reference numeral 20. The refuse collection vehicle 20 includes a cab 22, a frame 24 and a refuse stowage unit 26. The refuse stowage unit 26 also includes a hopper 28. A container collection arm 30 is secured to the hopper 28.

[0030] The container collection arm 30 includes a telescoping boom 32 and a grasping assembly 34. The grasping assembly 34 is secured to the boom 32 via a rotary actuator 36. The rotary actuator 36 manipulates the grasping assembly 34 to level the container during lifting. Additionally, the rotary actuator 36 initiates dumping of the container into the hopper 28. A hose track 38, housing the hydraulic hoses, is positioned on the boom 30. The hydraulic hoses are carried by the hose track 38 to the rotary actuator 36 and grasping assembly. The hose track 38 moves along the boom 32 as best illustrated in FIGS. 3 and 8-11.

[0031] The grasping assembly 34 includes a link arm 35 coupled with the rotary actuator 36. Additionally, a pair of fingers 31, 33 is actuated from the link arm 35 to capture the container. In FIG. 13, the link arm 35 is illustrated in a non-offset position for close container gripping or a storage position. The fingers 31, 33 include sensors 39. The sensors 39 may be of the pressure or positioning type to enable proper positioning of the gripping mechanism fingers 31, 33 on the container prior to the dump sequence. Additionally, the fingers 31, 33 may include a sensor such as a load cell 41 or the like that enables a determination of the weight of the container prior to the dumping sequence. By determining the weight of the container, dynamically, this enables the speed of the arm 30, during the dump sequence, to be adjusted based upon the weight of the container. Thus, with a lightweight container, the boom 32 may operate rapidly through the dump sequence to dump the container. In the event the container is heavy (e.g., 100 to 300 lbs.), the boom 32 can lift the container slowly and proceed through the dump sequence to dump the container at a slower speed. Alternatively, the hydraulic system could be utilized, via an

algorithm relating weight to the pressure/flow characteristics, to determine the weight of the container. Thus, the hydraulic pressure could be monitored to determine the weight and thus the sequence of dumping the container.

5 **[0032]** The boom 32 generally includes a plurality of stages that enable the boom 32 to telescope outward and inward to pick up and dump a container. The boom 32, with stages, can have a desired length and is preferably between 8 to 16 feet.

10 **[0033]** The boom 32 is secured onto the hopper 28 by a mounting assembly 40 and a movable cylinder 42. The mounting assembly 40 is secured to the hopper 28. The bearing journal enables the boom 32 to rotate about the bearing journal axis. The mounting assembly 40 includes a base 44. The base 44 includes the bearing journal 46 that receives the boom 32. The bearing journal is positioned inside of a base 44 that is secured to the hopper 28, as illustrated in FIGS. 6 and 7.

15 **[0034]** Alternatively, as illustrated in FIGS. 7a and 7b, a rail system 41 may be positioned on the hopper 28. The rail system 41 receives a bearing coupled with a bracket assembly 49. The bracket assembly 49 is slid along the rail system 41 via the cylinder 51. The mounting assembly 40 is secured to the bracket assembly 49. Thus, the mounting assembly 40 can be moved
20 horizontally on the hopper 28 to provide additional horizontal movement and provide additional length for the telescoping boom 32 during pick up as well as a reduced length during storage.

25 **[0035]** The pivot cylinder 42 includes a trunnion 52 mounted in a trunnion mount 50. The trunnion mount 50 enables the cylinder 42 to pivot along the axis of the trunnion pin 52. Thus, as the cylinder 42 is extended and retracted, the trunnion mount 50 enables the piston to rotate about the trunnion pin axis. As this occurs, the boom 32 is rotated about the bearing journal 46 which provides vertical movement at the end of the boom 32 that includes the rotary actuator 36. The cylinder 42 includes a mounting pin 54 that passes
30 through a clevis 56 on the boom 32 so that the cylinder 42 is rotatably secured with the boom 32.

[0036] As can be seen in FIG. 6 and 7, due to the nature of the mounting assembly 40, the container collection arm 30 can be easily removed from the mounting assembly 40. The container collection arm 30 can easily be repaired or replaced. Additionally, other types of arms, such as to pick up brush, cut trees, or the like, can be substituted for the container collection arm 30.

[0037] Thus, by actuating the cylinder 42, the boom 32 may be moved in a first degree of movement to provide vertical movement of the grasping assembly 34. Additionally, the boom 32 can be extended to provide a second degree of freedom of movement to move the grasping assembly horizontally. Further, the rotary actuator 36 can be rotated up and/or down to compensate for grasping the container. Thus, the container collection arm 30 is capable of picking up containers above and below the street grade the vehicle is traveling on, as illustrated in FIGS. 4 and 5. Additionally, the movement enables the opening of the container to be parallel to the ground regardless of the grade. Thus, this prevents tipping and loss of refuse in the container.

[0038] Additionally, an operator override may be present to enable the grasping of containers that are above and below the street grade of the vehicle. This requires the arm to be taken out of a normal range of operation for grasping the containers. The grasping sequence can be overridden by the operator so that the containers may be picked up above and below street grade of the vehicle.

[0039] FIG. 3 illustrates the container collection arm 30 moving between a pick up and a dump position. Here, the boom 32 is extended slightly when the trash container is on the ground and grasped by the grasping mechanism 34. As the boom 32 is rotated upwardly, the piston cylinder 42 is extended. Additionally, the rotary actuator 36 compensates to maintain the container in an upright position as illustrated. The piston cylinder 42 continues to extend as the boom continues to retract. Also, the rotary actuator 36 continues to rotate until the container reaches a dump position. As this occurs, the piston cylinder 42 is substantially extended through its entire stroke. The rotary actuator 36 is rotated so that the container dumps into the hopper 28. At this position, the rotary actuator 36 can be moved in a forward and reverse direction,

as illustrated by the two ended arrow in FIG. 3, to “shake” the container to provide an extra refuse evacuation sequence during dumping. Alternatively, a vibration mechanism 55 may be secured with the grasping mechanism 34 to “shake” the container to provide an extra refuse evacuation sequence during
5 dumping, as seen in FIG. 12. The cylinder 42, boom 32 and rotary actuator 36 are activated to reposition the container back onto the ground surface. Thus, the container collection arm 30 enables the container to be brought to a dumping location in a direct path from any reached distance while maintaining the container in an upright condition. This reduces the possibility of spillage of the
10 container contents.

[0040] The rotary actuator 36 ensures that the container is emptied. The rotary actuator 36, vibration mechanism 55, or other shaking devices, not directly related to the lifting motion, will enable the containers to be emptied without adding loads and stresses to the main lifting stages of the boom 32.
15 Additionally, a system to determine whether the container is empty may be added to the container collection arm 30. It will automatically modify the container collection arm 30 motion to empty the container. Container status can be derived from a number of methods such as weight, visual sensing, ultrasonic radar or the like which will transmit a signal back to the main lift controller. The
20 information will be used to either initiate shaking of the container to empty its contents or prevent the operator from extraneous shaking movement of the container. This reduces wear on the lifting arm and increases operator productivity by eliminating unneeded actions at each collection point.

[0041] Additionally, a sensor 65 may be positioned on the rotary
25 actuator link arm 35. The sensor 65 ensures that the link arm 35 is level with the grade of the ground. This enables the container opening to always be parallel with the ground prior to the dump sequence. This auto leveling feature enhances the ability to enable the container to be maintained upright as well as to be in a proper position for dumping. Also, sensor 65 will allow for the link arm
30 35 and grasping mechanism 34 to be rotated to a perpendicular position in reference to the ground so that containers that are not in an upright position can be collected.

[0042] The boom 32 includes a hydraulic manifold 60. The hydraulic manifold 60 includes connection portions 62 for the extended dump and end effector hoses. These are connected, via hoses, to the supply return of the hydraulic system. The positioning of the manifold 60 enables the hoses to be short and decreases the amount of movement of the hoses secured with the supply return mounted on the hopper 28. Additionally, supply lines 68 are positioned on the hopper 28 to operate the piston cylinder 42. The supply lines and actuator lines include quick disconnects so that they can be quickly connected and disconnected from one another.

[0043] Additionally, a camera 80 and a light 82 may be positioned onto the hopper 28 as illustrated in FIG. 1. The camera 80 and the light 82 provide the operator with a view of the container so that the container may be picked up by the operator from within the cab of the vehicle. The operator views a screen in the cab that illustrates the container. Thus, the camera 80 provides a view of the container so that the operator may easily grasp the container with the grasping mechanism 34. The screen may include some type of line scan or safety curtain to enable lining up and easy pick up of the container by the operator. Also, the light 82 may be present to provide illumination for the camera. This optimizes the field of view. The operator is provided with a controller, such as a joy stick, so that he would be able to manipulate the container collection arm 30 to pick up of the container. Once the container is grasped, the operator initiates the dumping sequence. The system determines the weight of the container and begin the dump sequence.

[0044] Also, the camera 80 may be mounted so that upon dumping of the container, the operator may view the inside of the container for a refuse verification check to ensure that the container is empty. Alternatively, the camera 80 and light 80 may be mounted on the container collection arm 30.

[0045] FIG. 8-11 illustrates a container pickup. In FIG. 8, the boom 32 is extended so that the grasping mechanism 34 is positioned about the container. In FIG. 9, the boom 32 has been retracted into a position to begin dumping the container. In FIG. 10, the boom has been rotated upwardly illustrating the relatively level vertical position of the container as it moves from

the ground surface to the hopper 28. FIG. 11 illustrates the extension of the piston cylinder 42 and the rotation of the rotary actuator 36 to dump the container into the hopper 28.

[0046] Thus, the container collection arm 30 is rotatably coupled with the hopper 28 as well as including a rotatable actuator 36. This configuration enables the grasping mechanism 34 to be positioned so that it is perpendicular to a container at any distance in height within the working area of the container collection arm 30. This enables optimal engagement with the waste container to reduce the possibility of damaging the container or spilling its contents. The mounting assembly 40 is attached to the front of the hopper 28 to reduce the overall weight of the assembly by using the body structure to raise the boom 32 pivot point above the chassis where the container collection arm 30 reach can be maximized. The mounting position of the container collection arm 30 raises the attachment point of the container collection arm 30 to an area where it is easily serviceable so that quick change of the container collection arm 30 for service and repair is possible.

[0047] Methods of operating the collection device are as follows. The operator selects a direct path or a low lift path to the hopper. The operator grips the input controller (joystick or other). The system senses the operator is present. The operator approaches a container. As the vehicle slows down, below a preset speed, the joystick is enabled. The operator moves the control to a reach position. A signal is sent to the chassis to restrict the speed of any forward movement of the vehicle as soon as the arm leaves its stored position. The boom cylinder extends, the lift cylinder extends to the level of the dump arm, and the rotary actuator rotates the grabber assembly and beam to assure that the container remains parallel to the ground. The operator, sensor, camera, or other device initiates closing of the grabber as the arms approach the container. When the optimum grabber point, as defined by the grabber and container type is reached, the extended functions are stopped. The container is firmly grabbed using a force feed back, grabbing the container. The operator moves the control lever to the dump position.

[0048] If the direct path is chosen, the controller calculates the most direct path to the hopper dumping position. Upon operator signal or after a preset time after the container is gripped, the container lifting and weighing is initiated. When the weight exceeds a preset limit, the operation of the arm will be slowed to control stresses within the arm structure. The boom cylinder is retracted, while the lift cylinder continues to extend until sensors reach the container raised position and is ready to dump. While raising the grabber, the beam continues to rotate to maintain the container level to the earth. While moving the container plus refuse, the weight is more precisely calculated. When reaching the dump position, the dump arm will rotate the container into the dump position emptying the contents into the hopper. If the container is not empty, a re-rotation of the dump arm/grabber is automatically initiated to dislodge the remaining contents. Alternatively, a vibratory or other method may be engaged to dislodge the container contents. When the container is determined to be empty, the container will be rotated back toward the level position. As soon as the container has rotated far enough to clear the edge of the hopper, the arm lift cylinder will begin retracting to lower the container. The boom cylinder will extend to return the container to the position as it was picked up. The controller will follow the reverse path of the lift cycle to directly return the container.

[0049] If the low lift path is chosen, upon operator signal or after a preset time after verifying the container is gripped, the boom cylinder is retracted, while the lift cylinder continues to retract until sensors determine the container has reached the side of the vehicle body. The container is maintained at a height that is raised slightly to clear the ground surface while it is retracted. Upon operator signal or after a preset time after the container is gripped, container lifting and weighing is initiated. When the weight exceeds a preset limit, the operation of the arm will be slowed to control stresses within the arm structure. While retracting the grabber, the beam continues to rotate to maintain the container level to the earth. As soon as the container reaches the side of the vehicle body, the lift cylinder begins to extend, and the boom cylinder extends then retracts to compensate for the rotary motion. As the grabber is raised, the beam continues to rotate to maintain the container level to the earth. While

moving the container plus the refuse, the weight is more precisely calculated. When the dump position is reached, the dump arm will rotate the container into the dump position emptying its contents into the hopper. If the container is not empty, a re-rotation of the dump cylinder is automatically initiated to dislodge its contents. Alternatively, a vibratory or other method may be engaged to dislodge the container of its contents. When the container is determined to be empty, the container is rotated back toward the level position. As soon as the container has rotated far enough to clear the edge of the hopper, the arm lift cylinder begins to retract lowering the container. Also, the boom cylinder extends to return the container to the position as it was picked up. The controller will follow the reverse path of the lift cycle to directly return the container to the lower position at the side of the vehicle body. The controller will then automatically extend the boom and raise cylinder, while rotating the dump arm to return the container to the pickup position. When the container is at the pickup position, the operator will command the grabber to release the container. The grabber will open. As soon as the grabber has retracted far enough from the container, the boom cylinder and lift cylinder will start to retract. The boom will pull in with the grabber remaining level to the stored position. A signal is sent to the chassis to allow full vehicle speed.

[0050] Turning to FIGS. 14 and 15, an additional embodiment is illustrated. The collection vehicle, including the cab 22, frame 24, refuse stowage unit 26 and hopper 28, is substantially identical. Here, the difference is in the container collection arm 130. Again, the container collection arm 130 includes a telescoping boom 132 secured with the hopper 28. The boom 132 is secured with the hopper 28 so that the boom 132 provides horizontal movement at a constant height. An arm 132 is secured with the end of the telescoping boom 132. The other end of the arm 132 includes a grasping mechanism 134 to grab refuse containers. The arm 132 includes a plurality of rotary actuators 136, 138, 140. The rotary actuators 136, 138, 140 are provided at pivot locations of the arm 132. Thus, the arm includes links 142, 144 between the rotary actuators 136, 138, 140. The links 142, 144 pivot about the rotary actuators to enable the container to be moved from the collection to the dump position as illustrated in

FIG. 15. Thus, the container is picked up as the rotary actuators 136, 138, 140 rotate to pivot the links 142, 144 with respect to one another to enable the waste container to be dumped into the hopper 28, as illustrated in FIG. 15.

[0051] FIGS. 16 and 17 illustrate an additional embodiment of the disclosure. The collection vehicle is substantially the same as that described including a cab 22, a frame 24, a refuse stowage unit 26 and a hopper 28. The container collection arm 230 is positioned underneath the hopper 28. The container collection arm 230 includes a telescoping boom 232 that includes a grasping mechanism 234. The grasping mechanism 234 moves vertically along a support 236. The telescoping boom 232 extends horizontally from the vehicle to grasp a container. The telescoping boom 232 is retracted into the vehicle. The telescoping boom aligns the support 236 with a track 238 having a candy cane configuration. The grasping mechanism 234 begins to ride upward along the support 236 and then onto the candy cane track 238 to a dump position as illustrated in FIG. 17.

[0052] The foregoing description of the embodiments has been provided for purposes of illustration and description. It is not intended to be exhaustive or to limit the disclosure. Individual elements or features of a particular embodiment are generally not limited to that particular embodiment, but, where applicable, are interchangeable and can be used in a selected embodiment, even if not specifically shown or described. The same may also be varied in many ways. Such variations are not to be regarded as a departure from the disclosure, and all such modifications are intended to be included within the scope of the disclosure.

25

CLAIMS

What is claimed is:

1. A refuse collection vehicle comprising:
a vehicle with a refuse stowage unit secured to the vehicle;
5 a hopper coupled with the refuse stowage unit for receiving refuse;
an arm for grasping containers and emptying the containers in the
hopper; and
the arm including a telescoping boom coupled with the refuse
stowage unit, a grasping mechanism is coupled with an end of the telescoping
10 boom, the grasping mechanism is adapted for grasping containers, the grasping
mechanism including at least one rotatable actuator for moving the container
between a pick up position and an empty position, and the grasping mechanism
including at least one moveable finger for coupling with the container for
enabling pick up of the container.
15
2. The refuse collection vehicle of Claim 1, further comprising the
telescoping boom being pivotally secured to the refuse stowage unit.
3. The refuse collection vehicle of Claim 2, further comprising a pivot
20 bearing assembly coupled with the hopper for receiving the telescoping boom.
4. The refuse collection vehicle of Claim 3, further comprising a
cylinder mounted on the hopper and coupled with the telescoping boom for
moving the boom in two degrees of movement.
25
5. The refuse collection vehicle of Claim 1, wherein the arm is readily
removable from the vehicle.
6. The refuse collection vehicle of Claim 5, wherein an arm with a
30 different function can be substituted onto the vehicle.

7. The refuse collection vehicle of Claim 1, wherein the arm enables pick up of containers above and below street grade on which the vehicle is traveling.

5 8. An arm for a refuse vehicle comprising:
a telescoping boom adapted for coupling with the refuse stowage unit, a grasping mechanism coupled with an end of the telescoping boom, the grasping mechanism adapted for grasping containers, the grasping mechanism including at least one rotatable actuator for moving the container between a pick
10 up position and an empty position, and the grasping mechanism including at least one moveable finger for coupling with the container for enabling pick up of the container.

15 9. The arm of Claim 8, further comprising the telescoping boom adapted to be pivotally secured to the refuse stowage unit.

20 10. The arm of Claim 9, further comprising a pivot bearing assembly removably coupled the telescoping boom and adapted for coupling with the hopper.

11. The arm of Claim 10, further comprising a cylinder coupled with the telescoping boom for moving the boom.

25 12. The arm of Claim 8, wherein the arm is readily removable from a vehicle.

13. The arm of Claim 12, wherein a grasping mechanism with a different function can be coupled with the arm.

30 14. The arm of Claim 8, wherein the arm enables pick up of containers above and below grade of a street on which the vehicle is traveling.

15. The arm of Claim 8, further comprising a sensor providing signals to a controller to automatically level the grasping mechanism to assure that an opening of a picked up container is parallel to a ground surface prior to dumping.

5 16. The arm of Claim 8, further comprising a mechanism for extra refuse evacuation during a dumping sequence.

17. The arm of Claim 16, wherein the mechanism is a vibratory mechanism.

10

18. The arm of Claim 16, wherein the mechanism is a two direction of rotation of the rotatable actuator.

15 19. The arm of Claim 8, further comprising a sensor for determining a weight value of the container.

20. The arm of Claim 8, further comprising a camera for enabling viewing by an operator for picking up a container.

20 21. The arm of Claim 1, further comprising a mechanism coupled with the hopper for enabling the arm to be multi-positioned on the hopper.

25 22. A pivot assembly for receiving a telescoping boom comprising:
a bearing assembly adapted to be coupled with a refuse container;
and
a base coupled with the bearing assembly, the base including a mechanism for securing the telescoping boom.

23. A grasping mechanism in combination with a telescoping boom comprising:

a telescoping boom;

5 a grasping mechanism comprising a rotatable actuator for moving a container between a pick up position and an empty position, the rotatable actuator coupled with the telescoping boom;

a link coupled with the rotatable actuator;

10 at least one moveable finger for coupling with the container, the at least one moveable finger coupled with the link; and

a mechanism for controlling movement of the telescoping boom and grasping mechanism such that as the container is grasped, an opening of the container remains parallel to a ground surface as the container is manipulated by the telescoping boom and grasping mechanism.

15

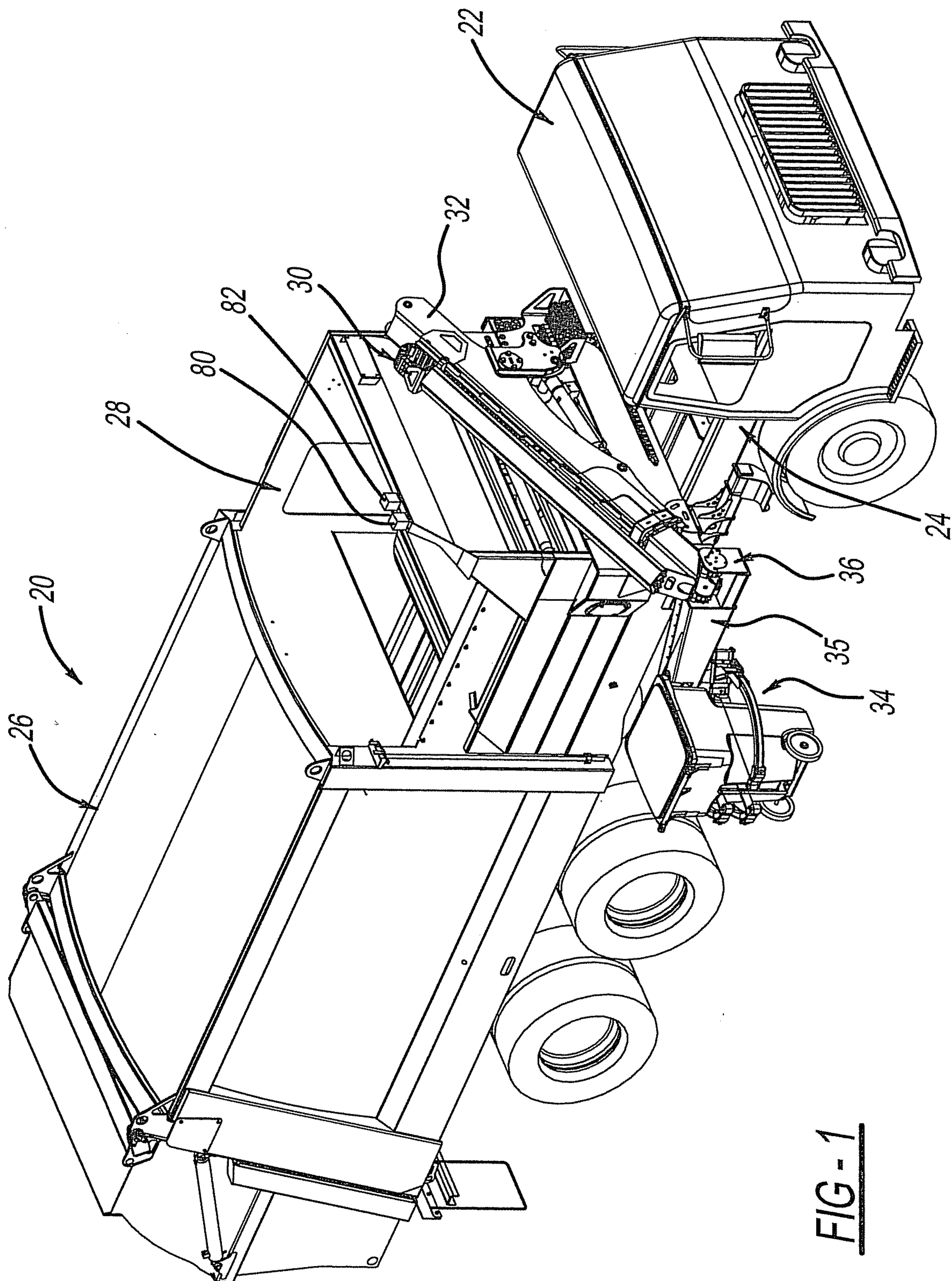

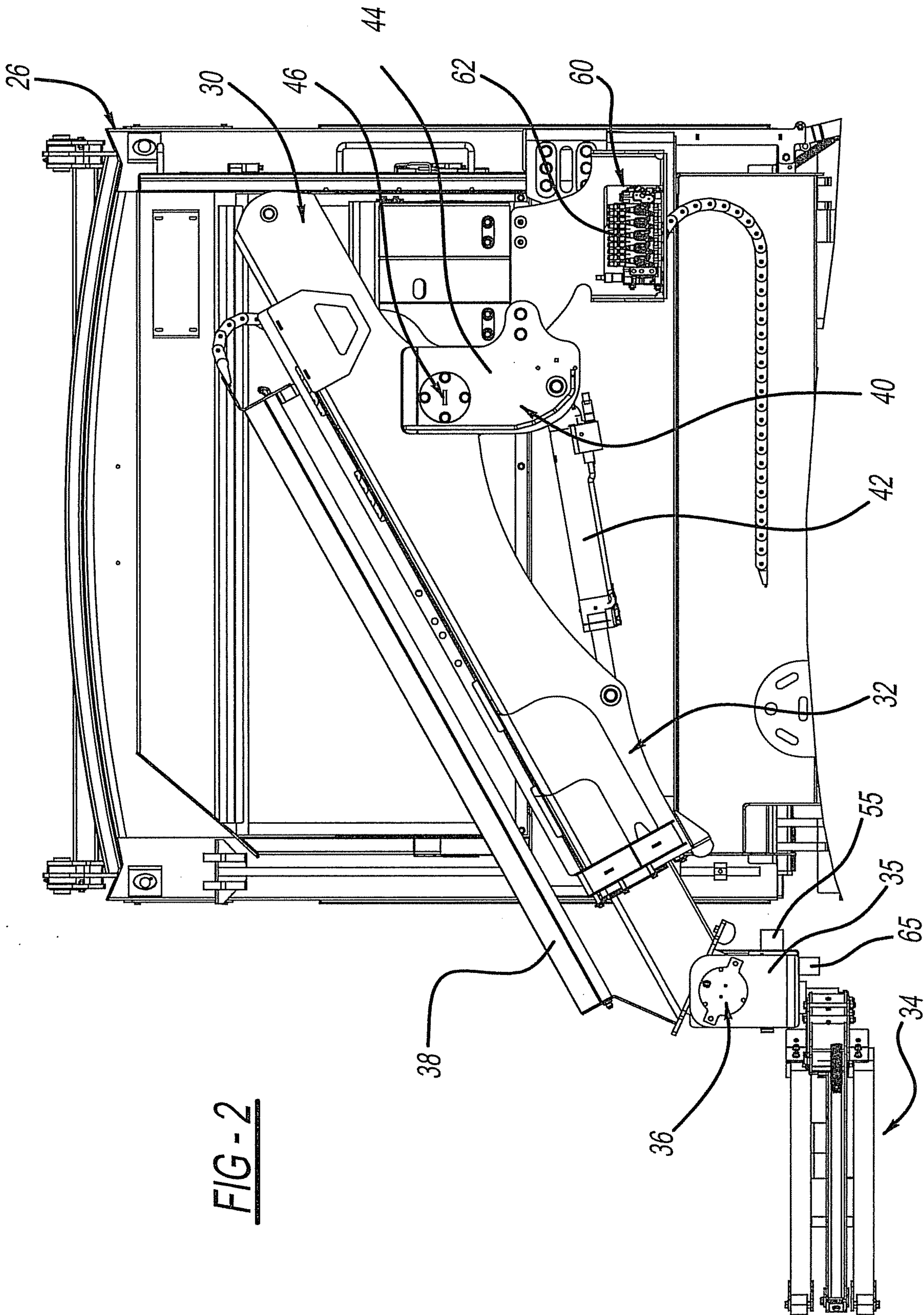

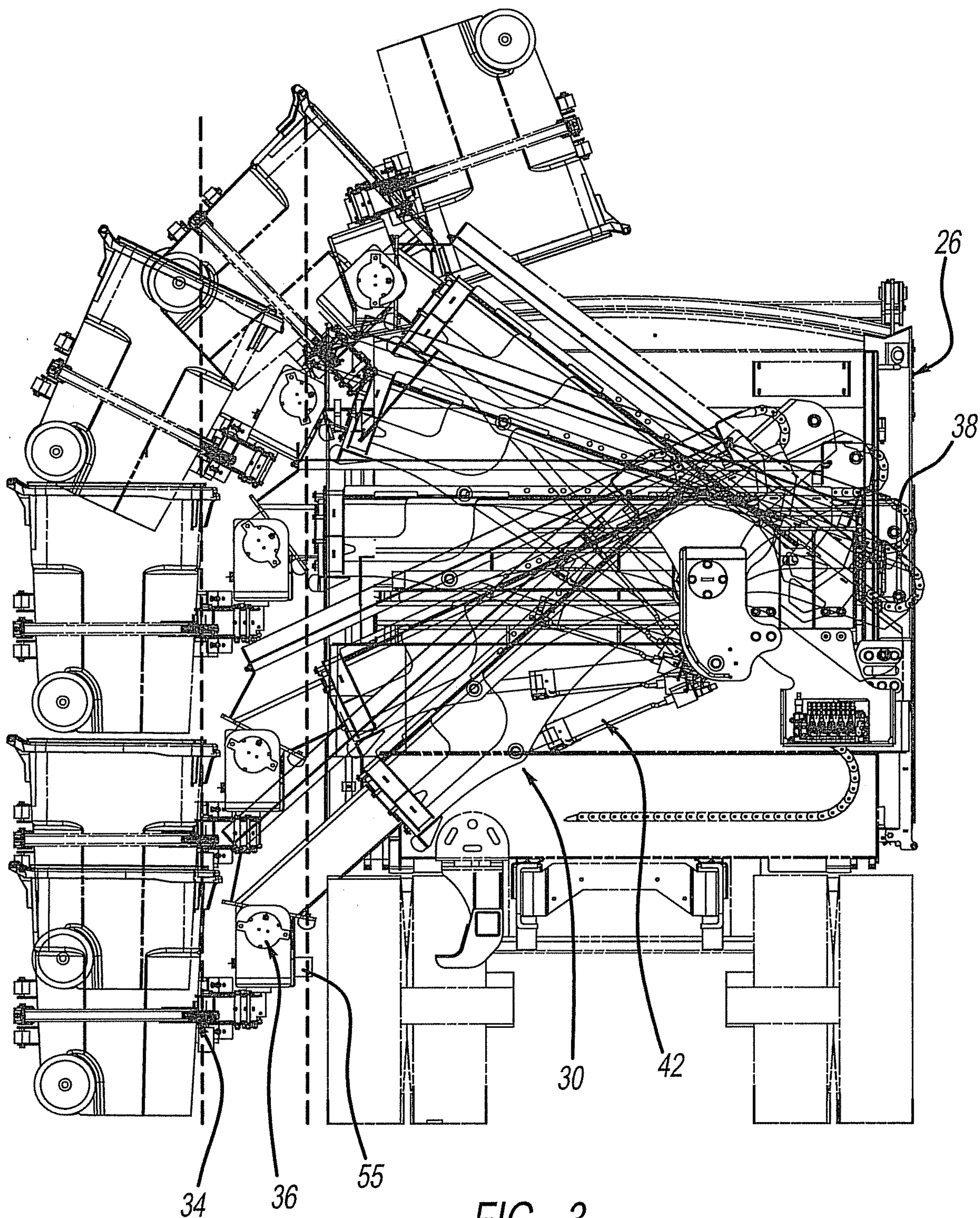

FIG - 3

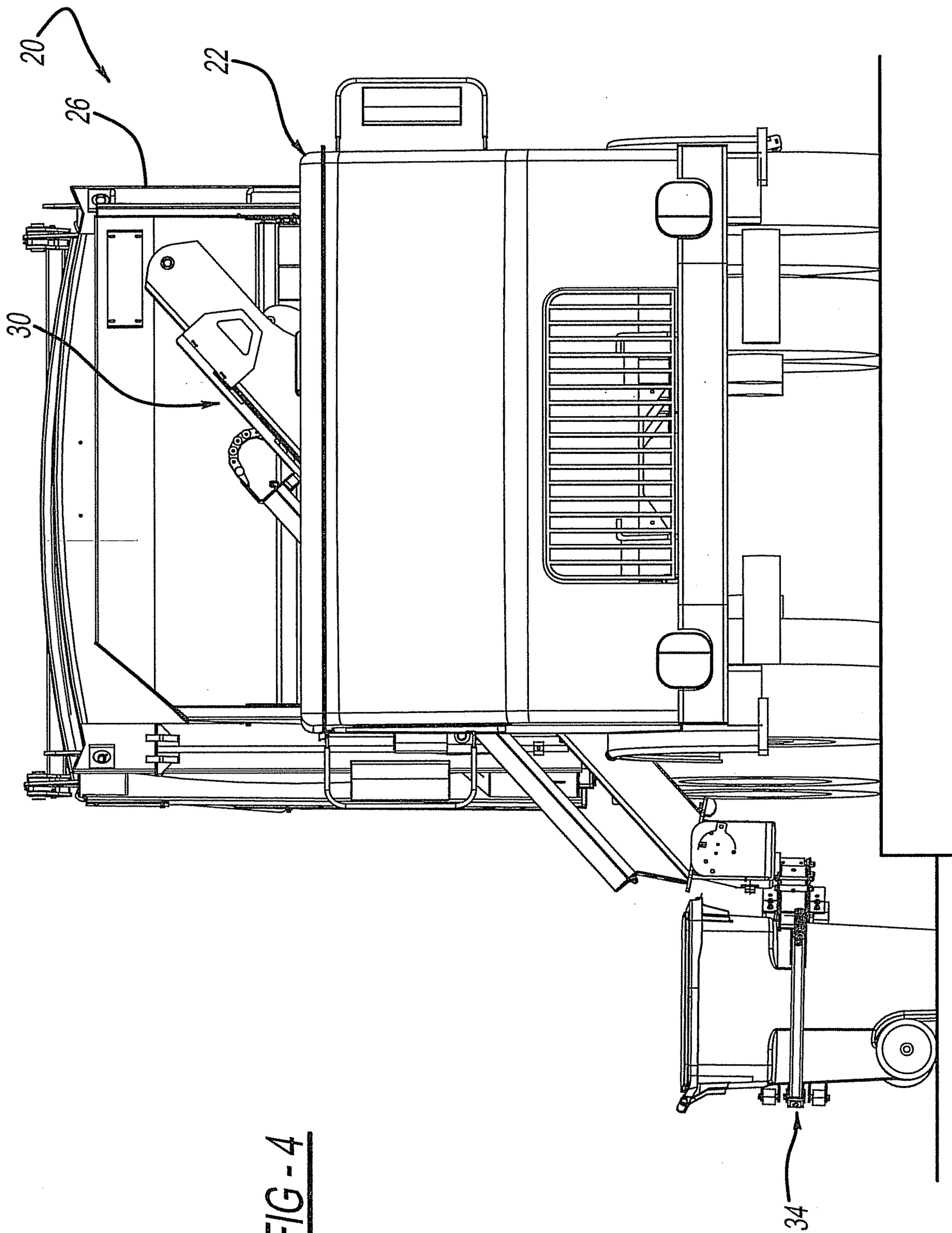

FIG - 4

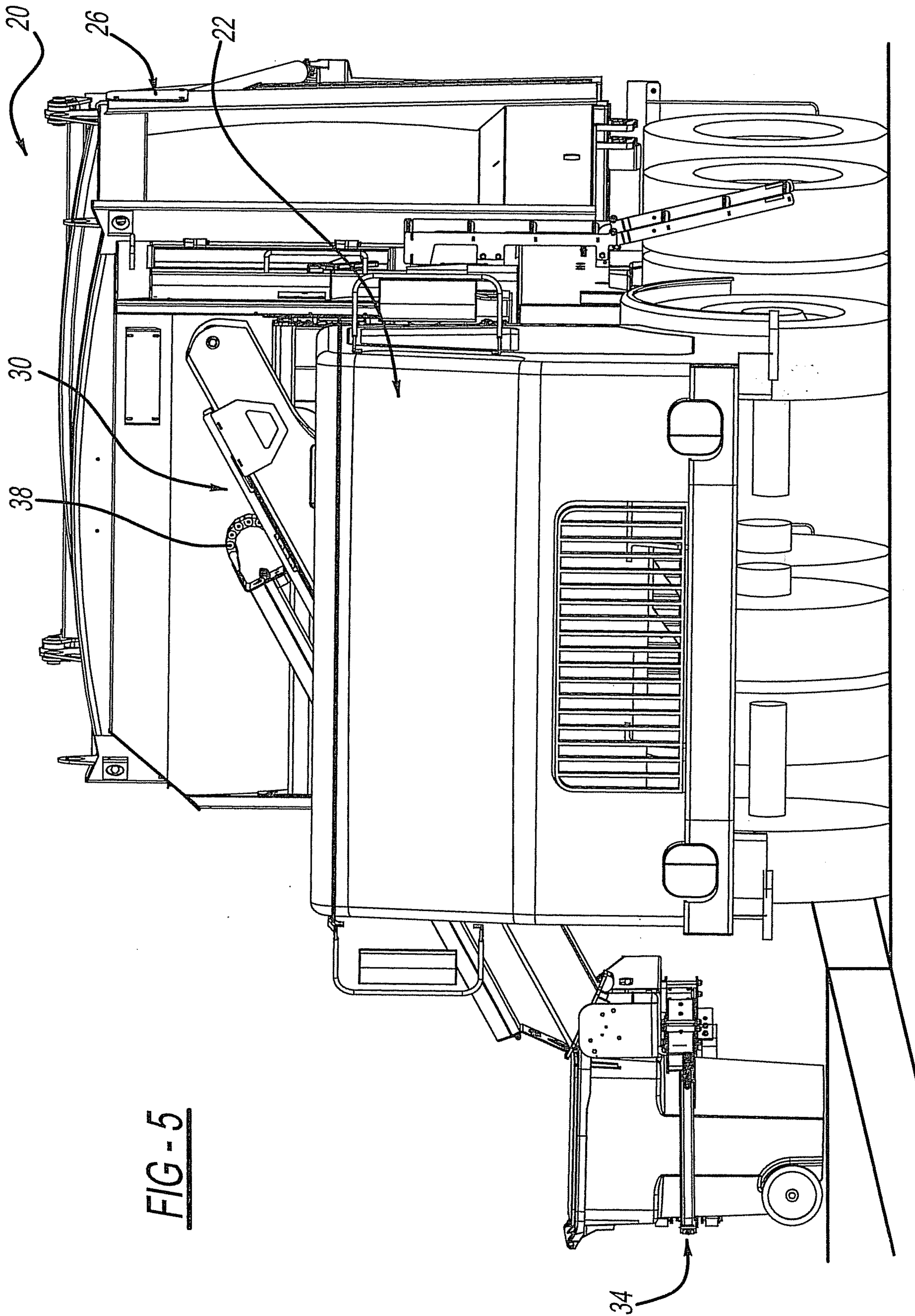

FIG - 5

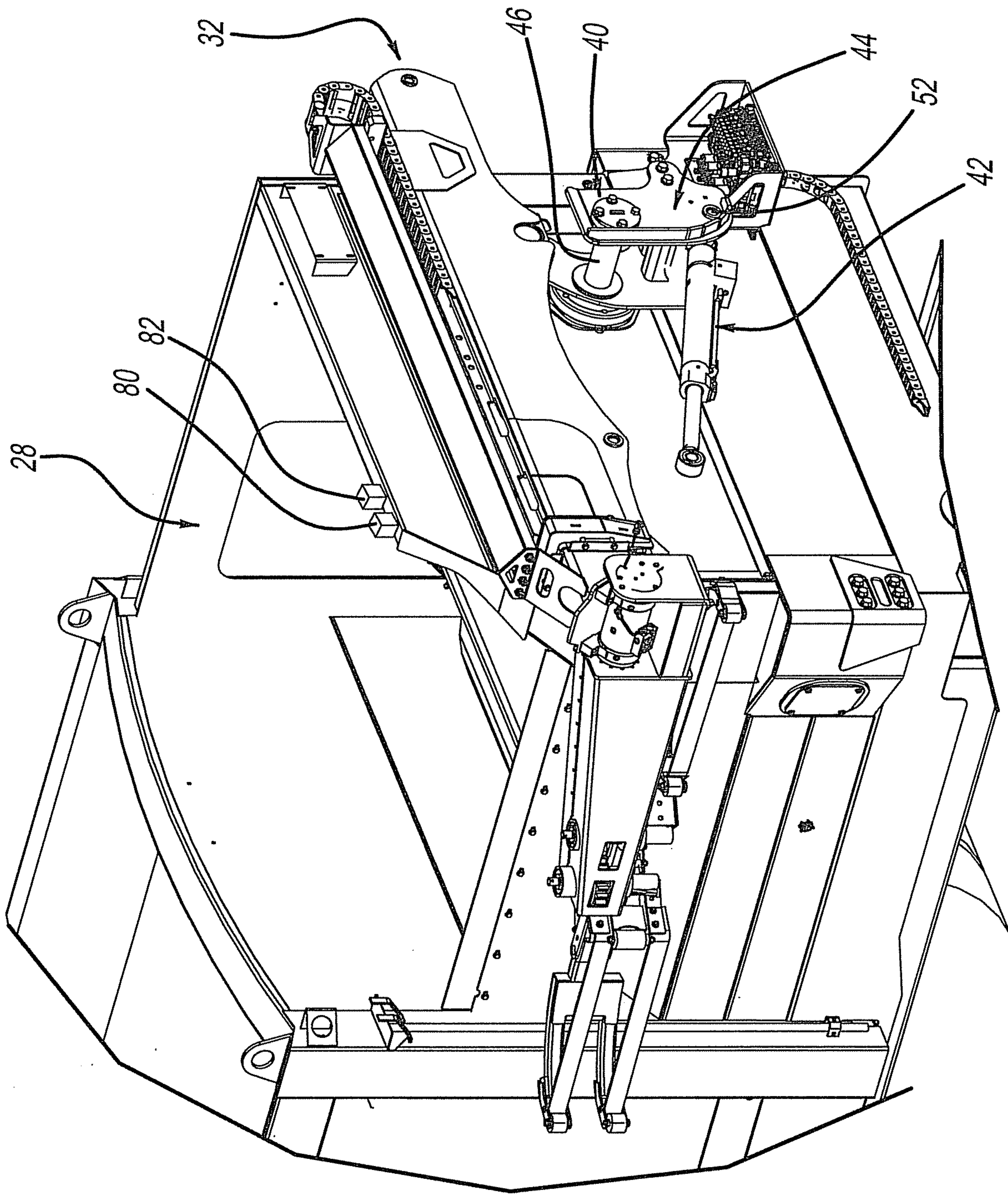

FIG - 6

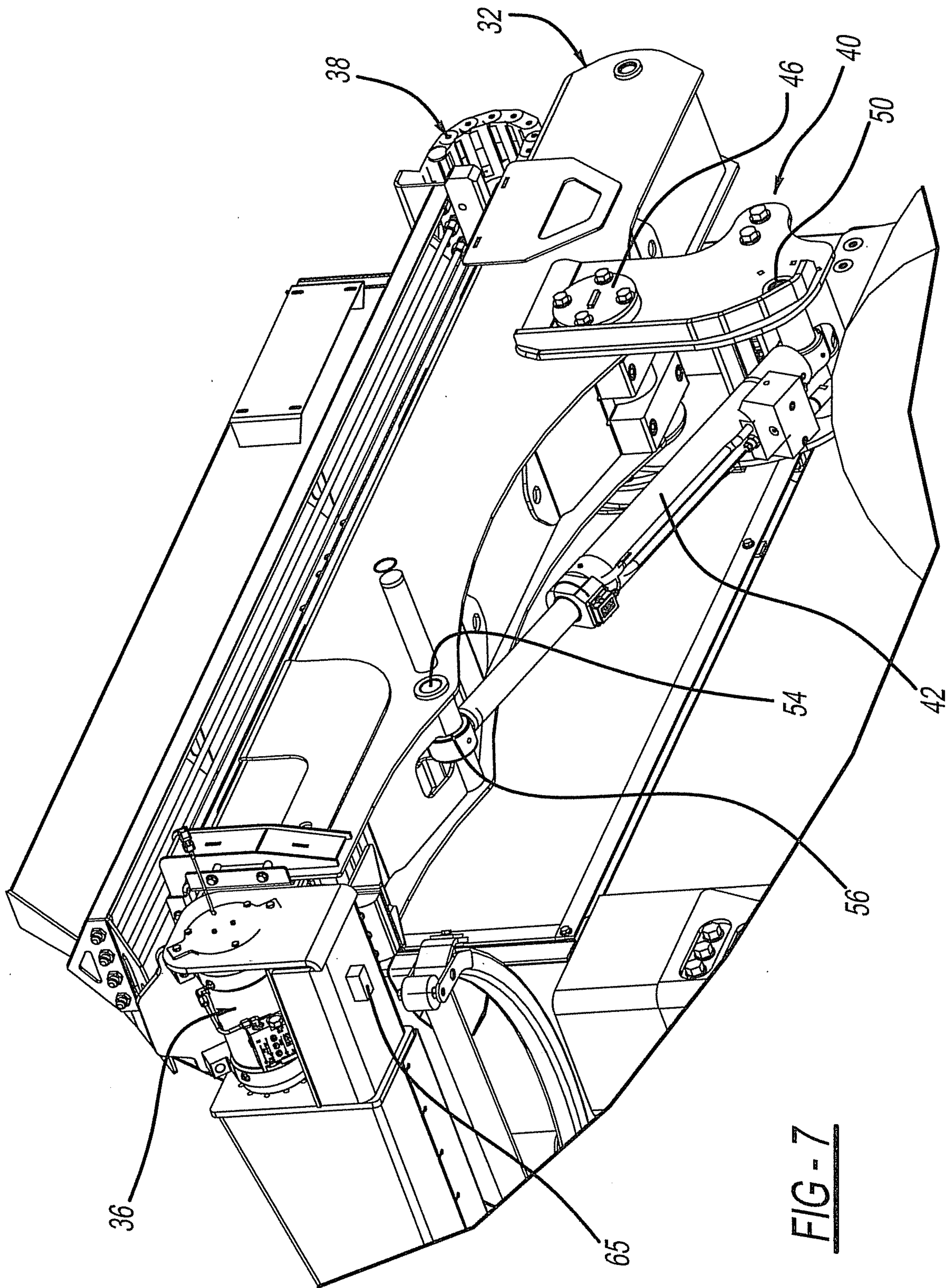

FIG - 7

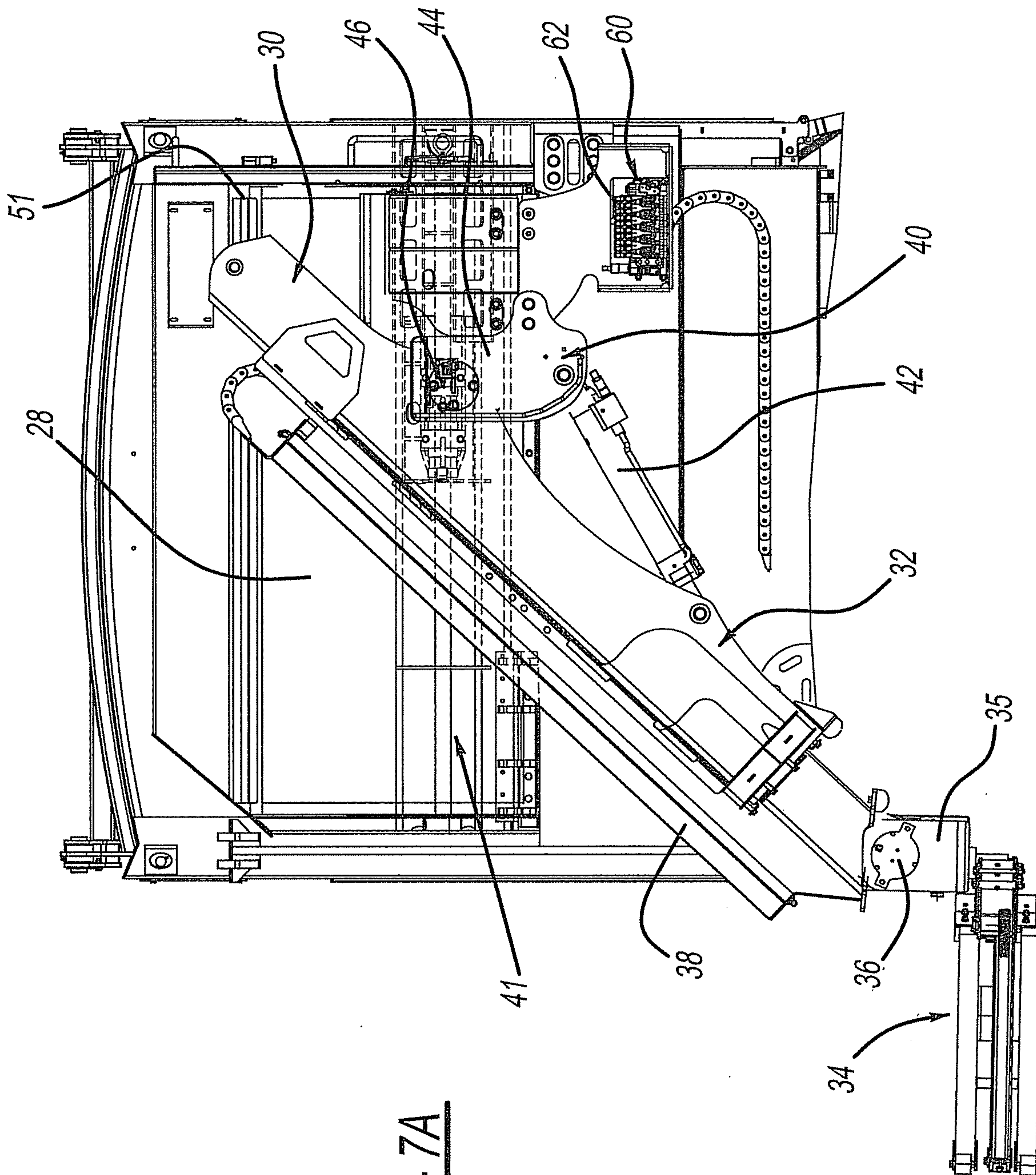

FIG - 7A

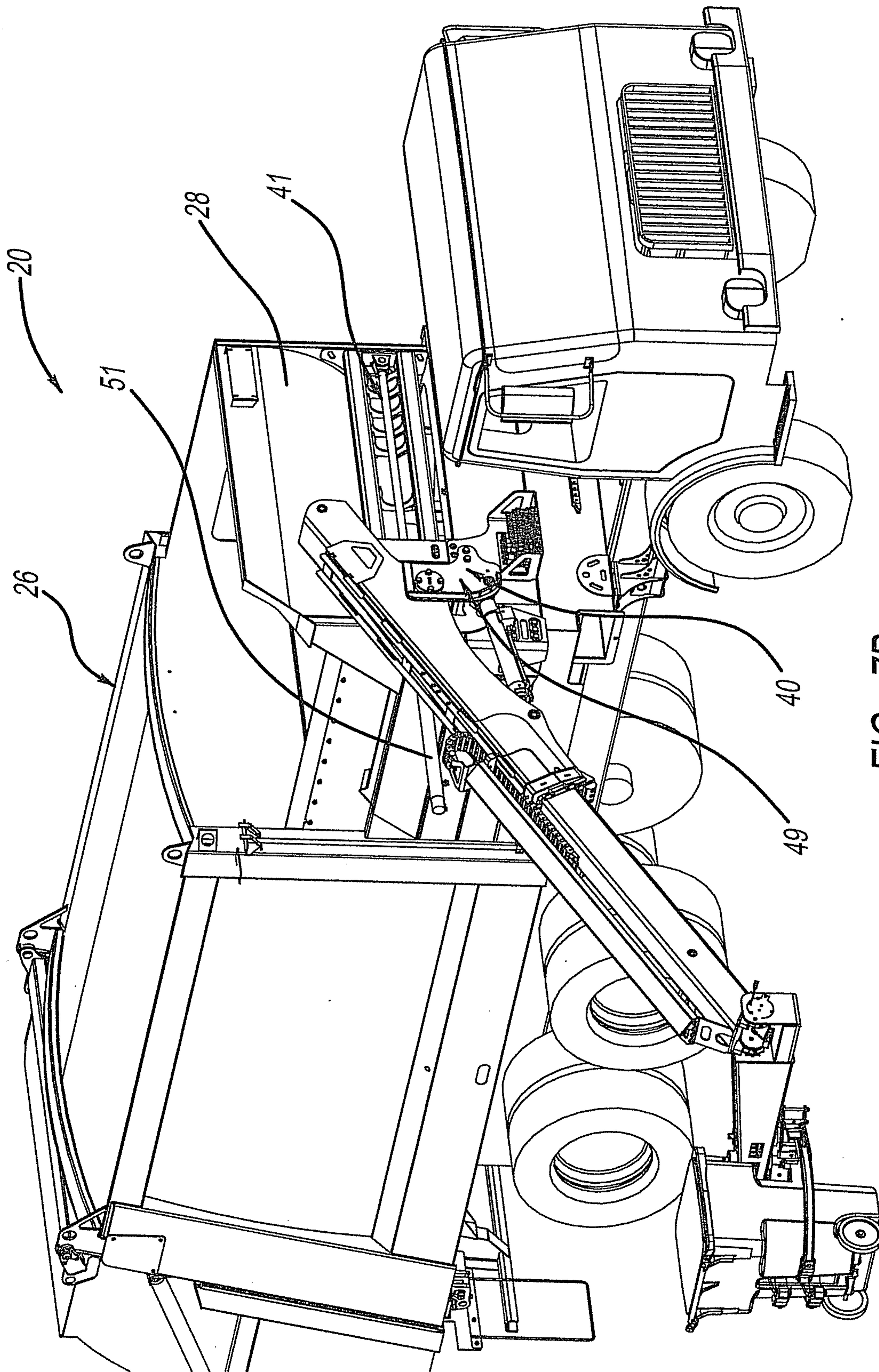

FIG - 7B

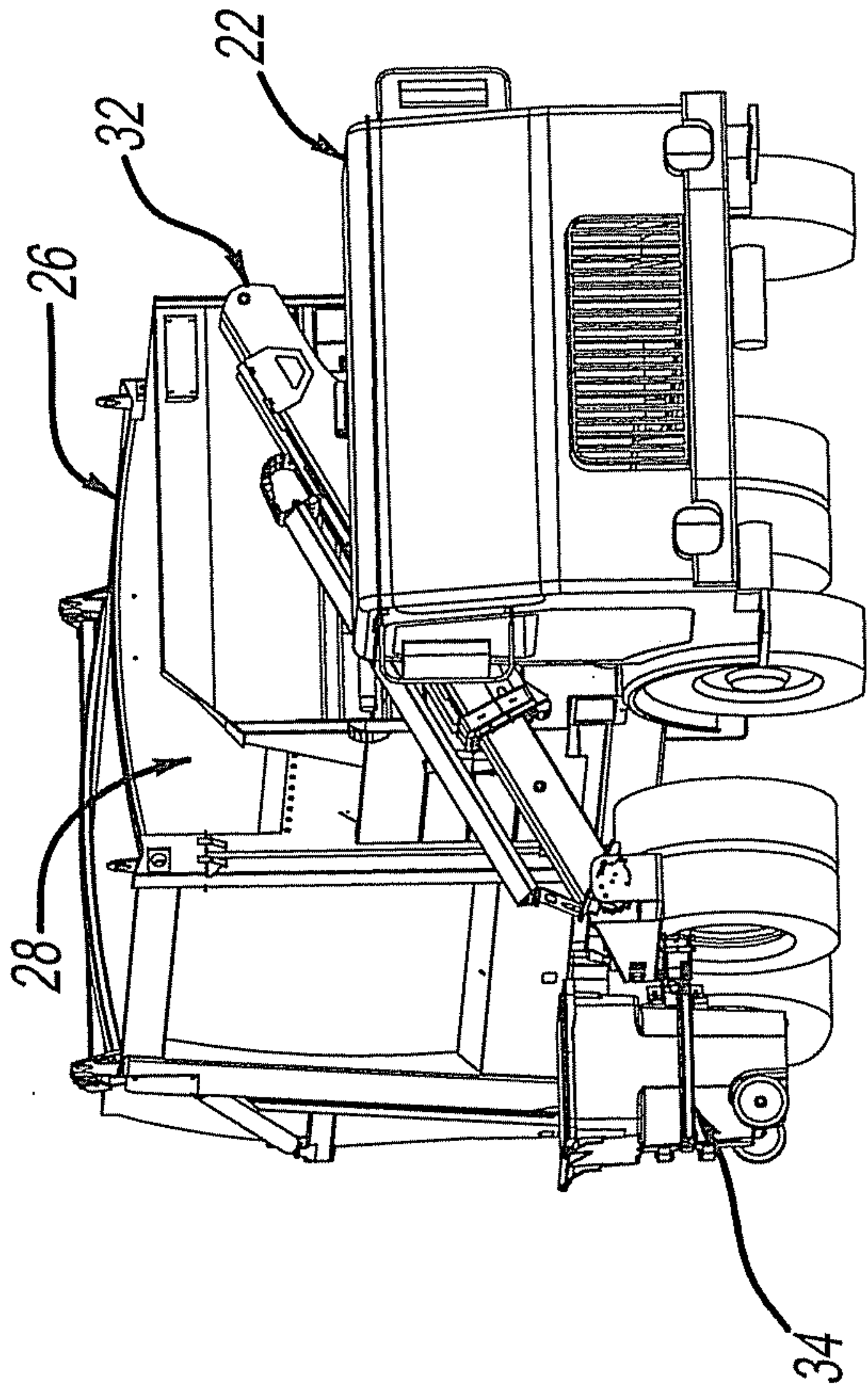

FIG-9

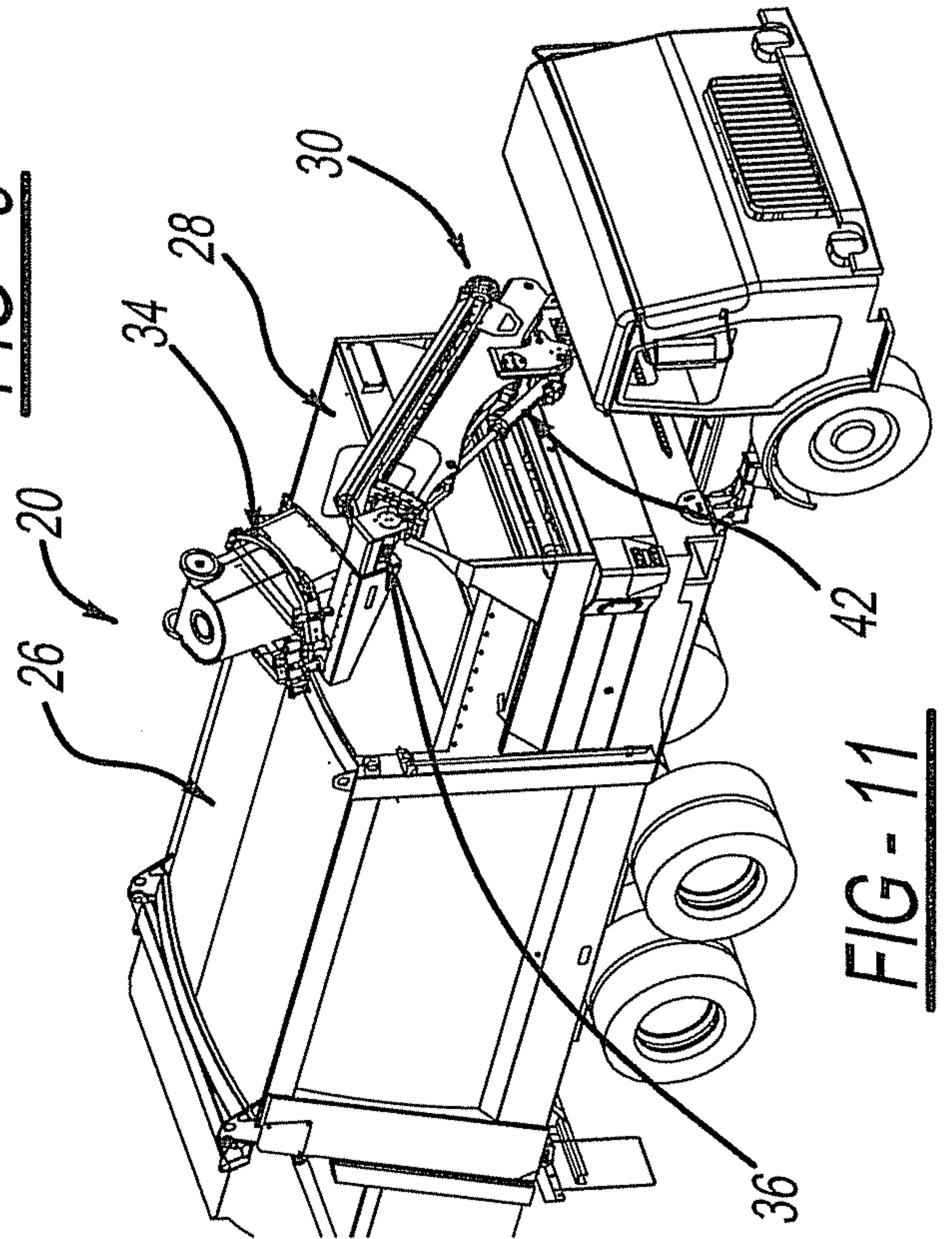

FIG-11

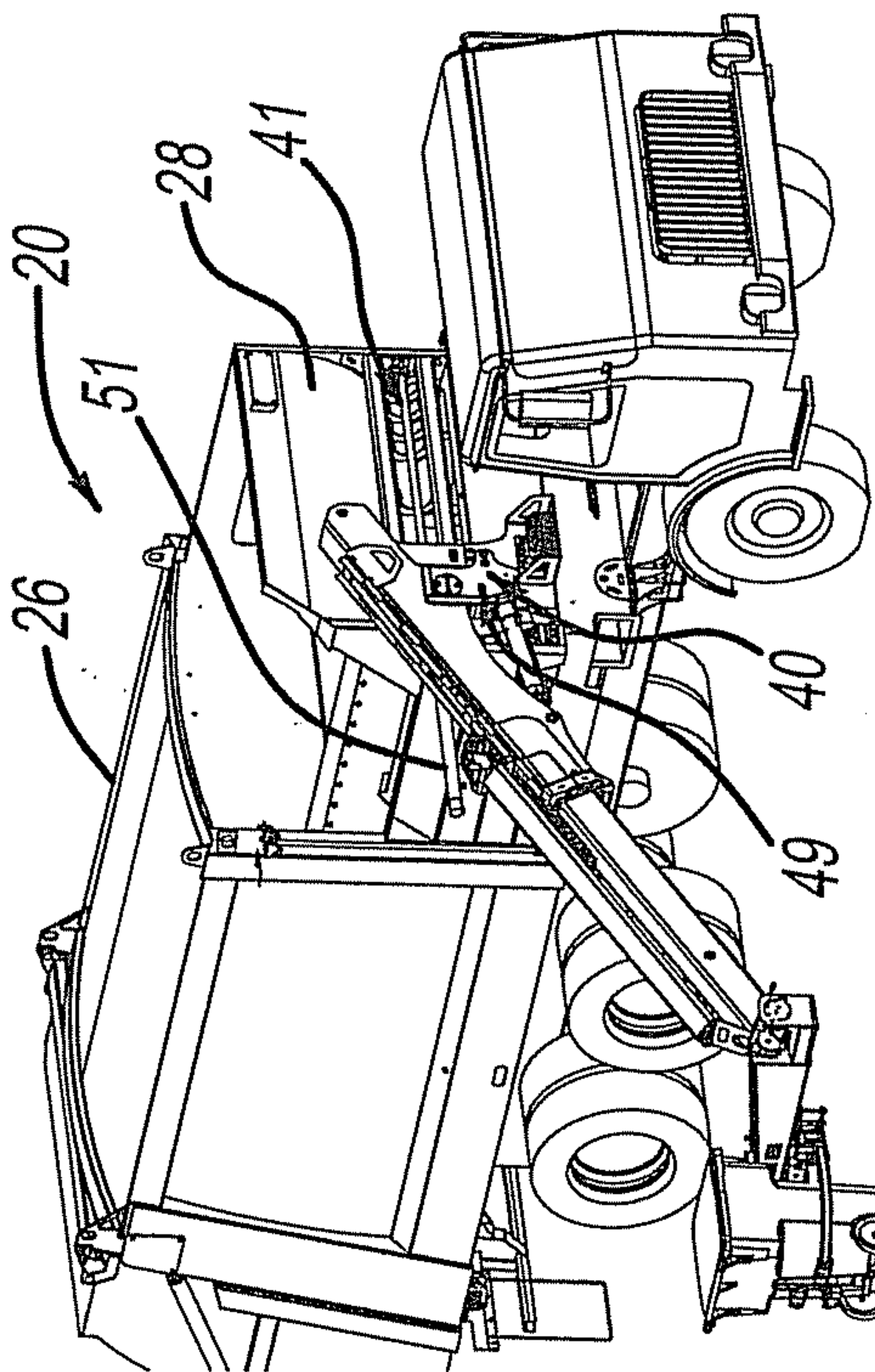

FIG-8

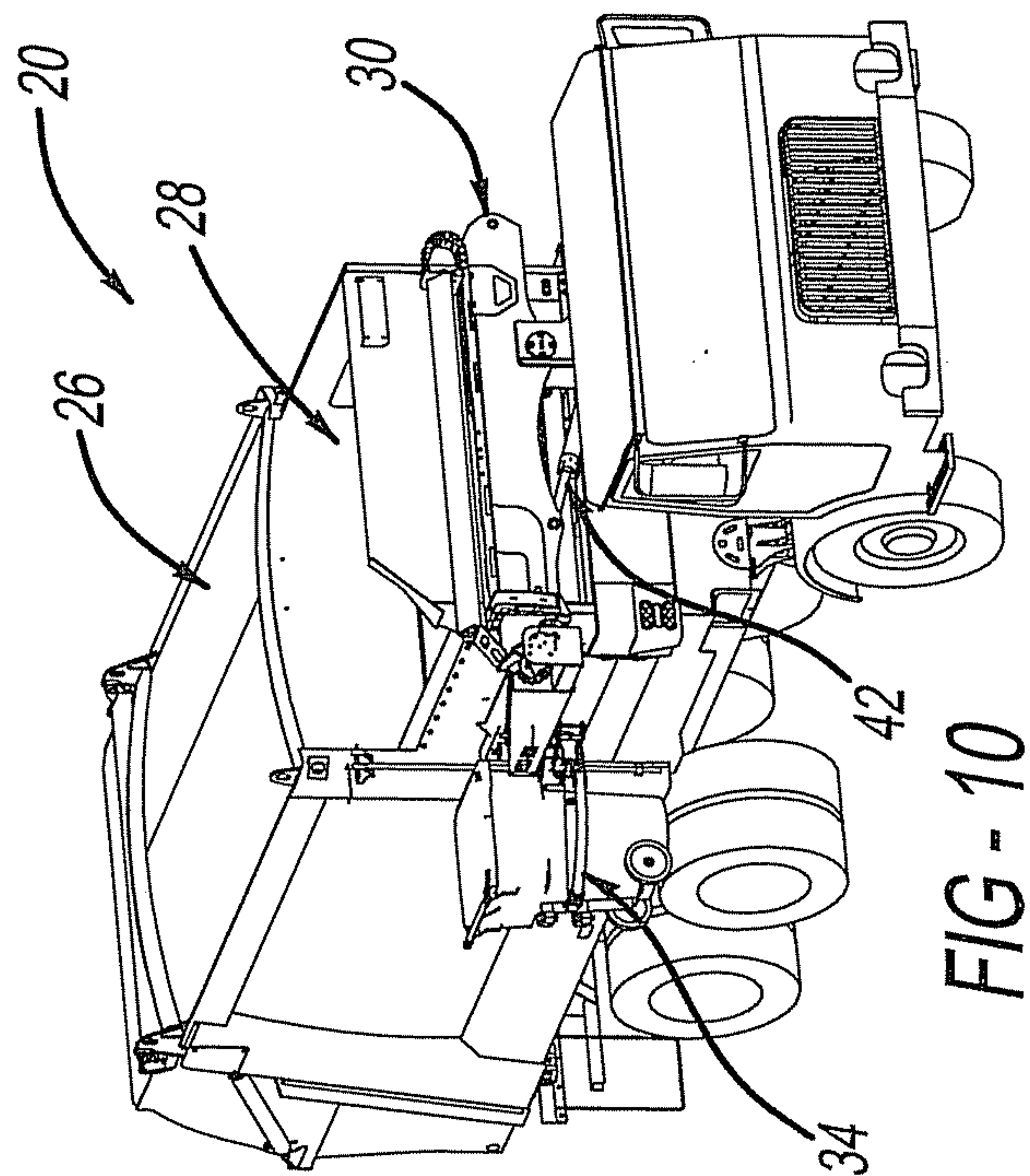

FIG-10

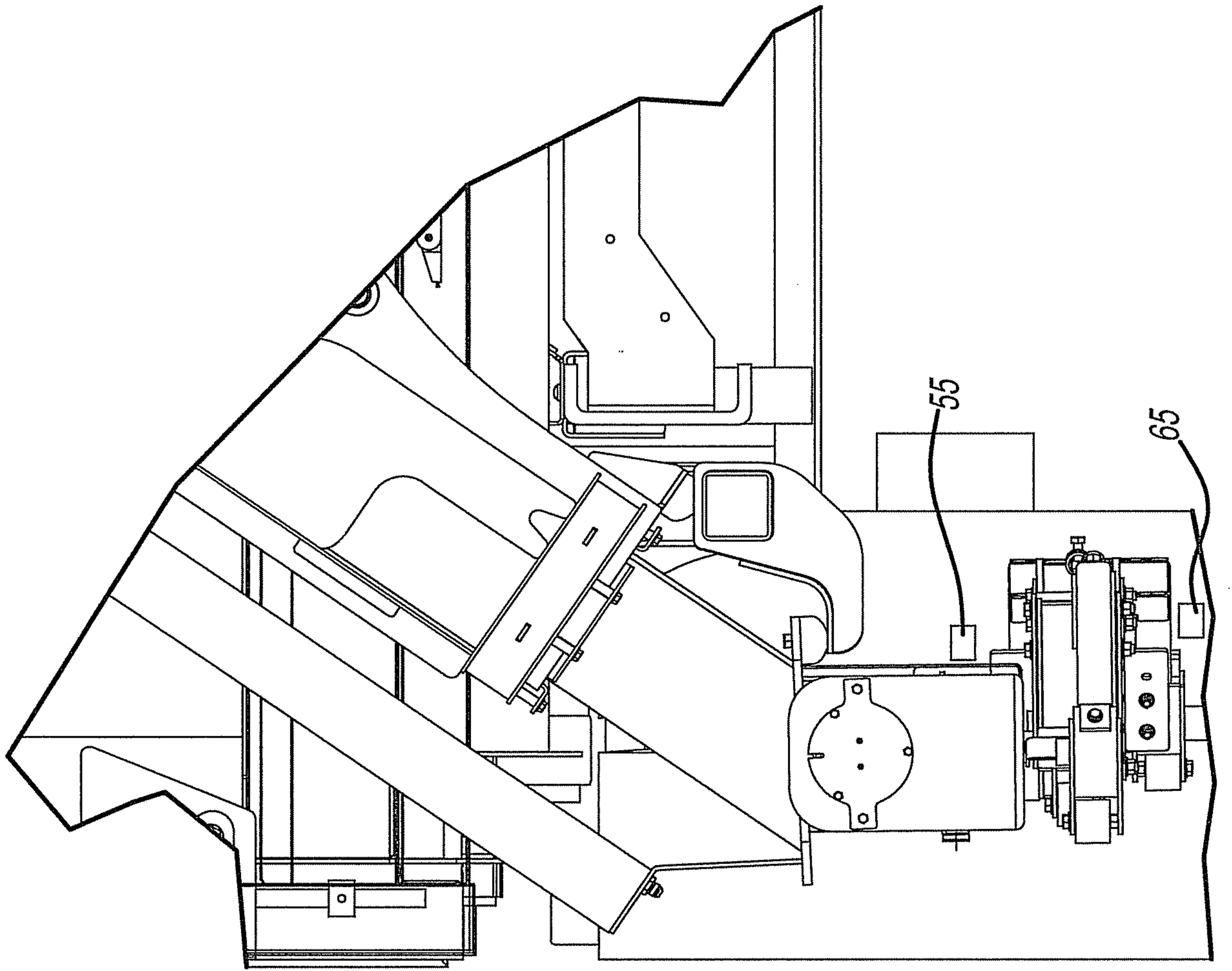

FIG - 12

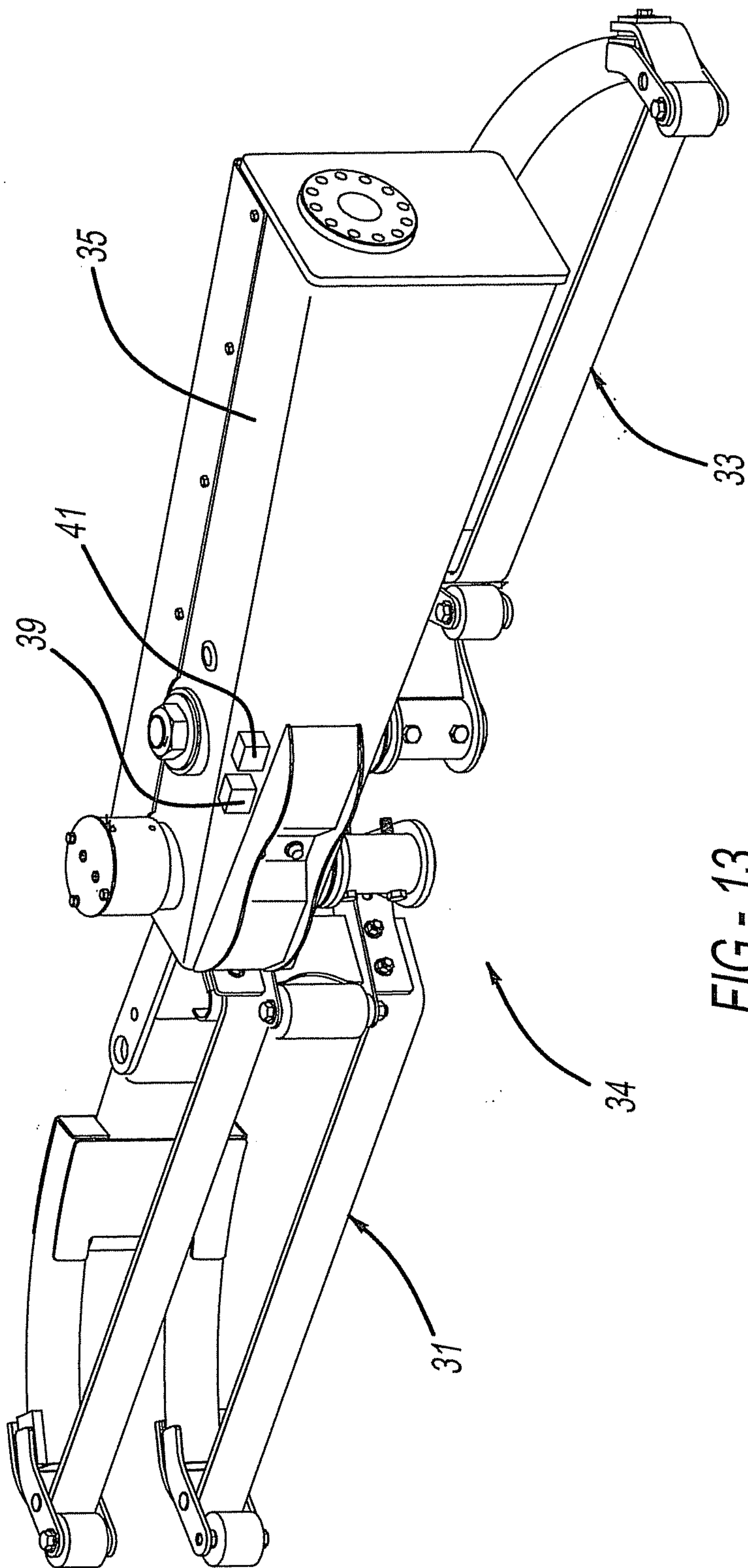

FIG - 13

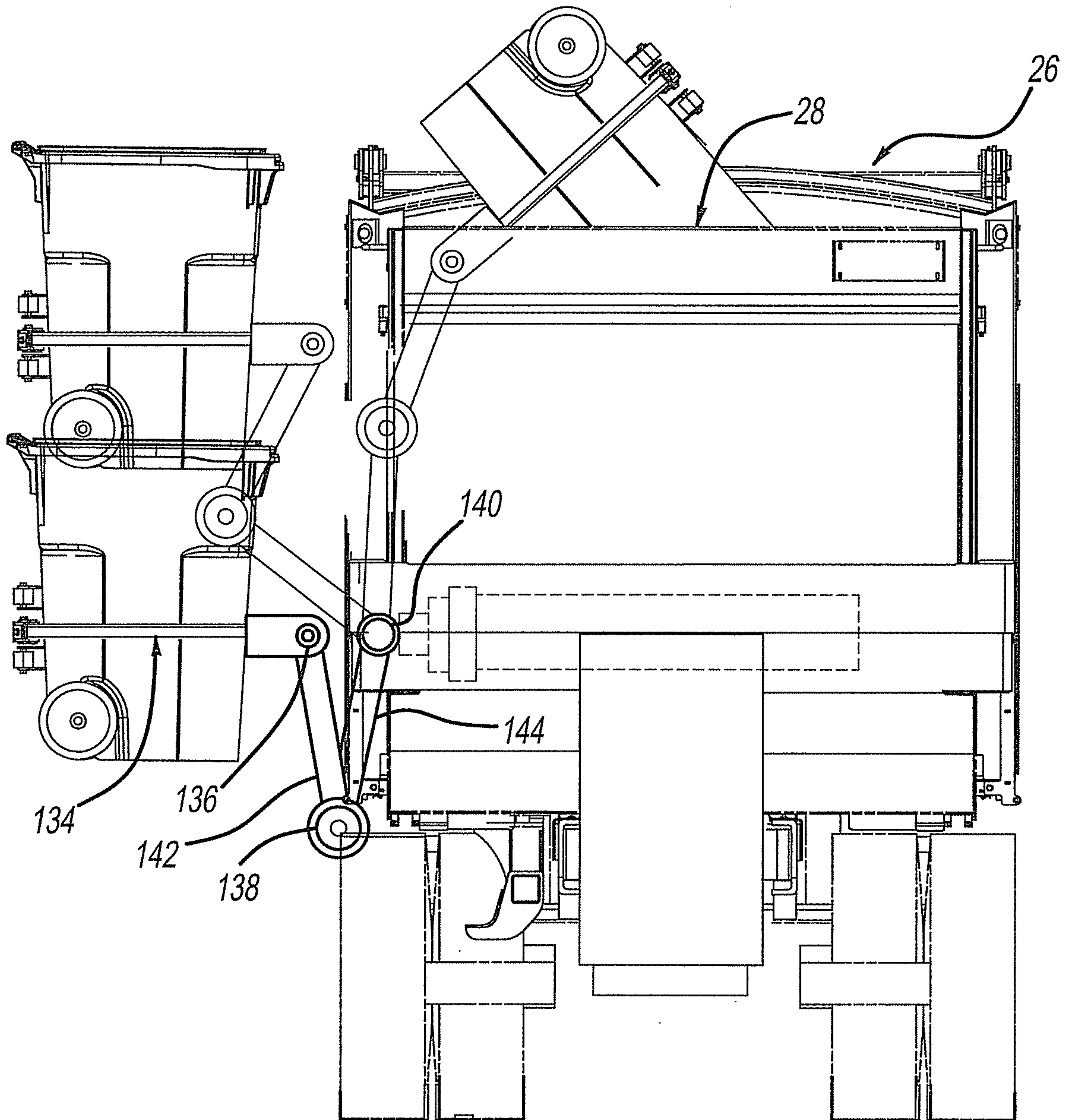
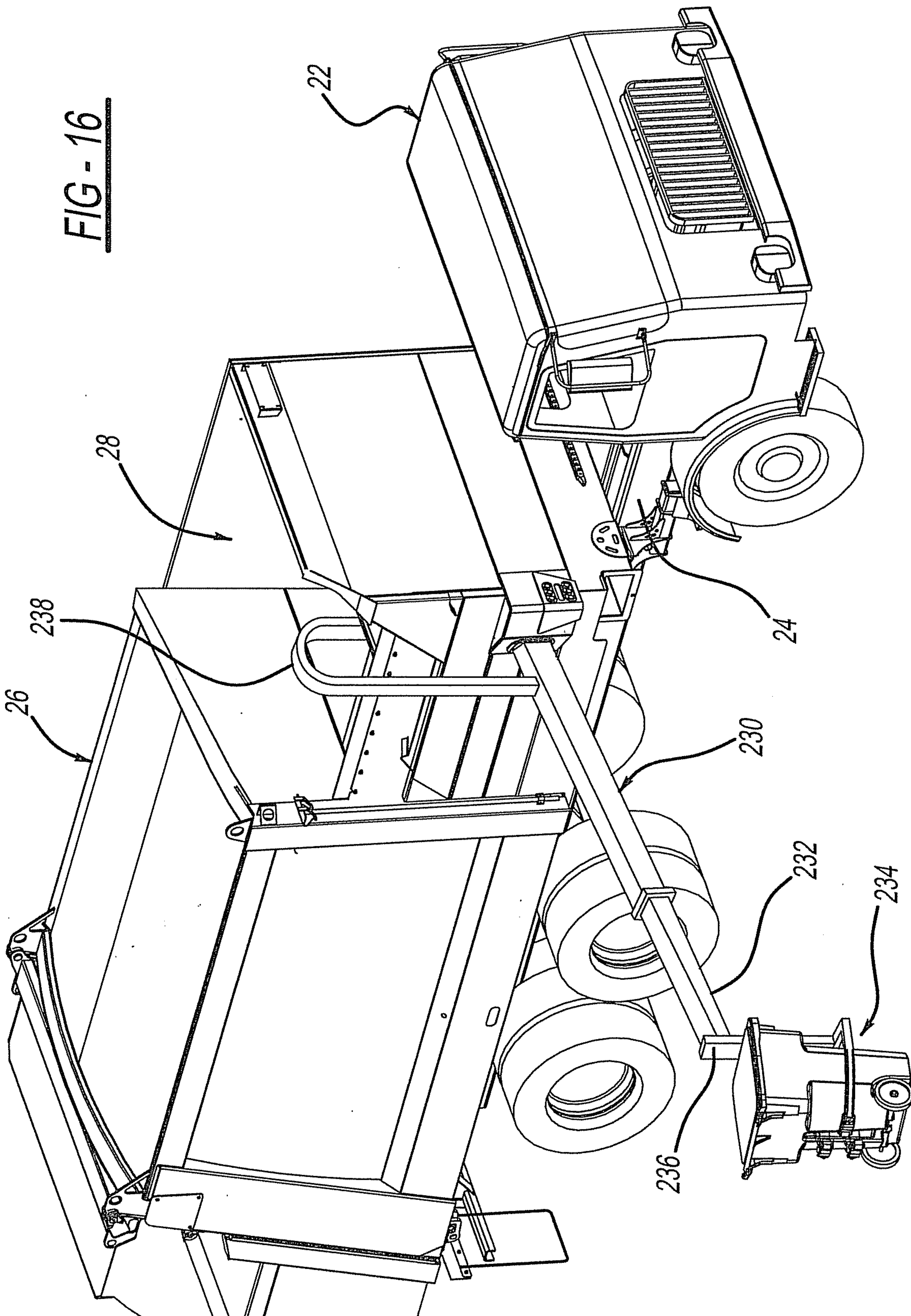

FIG - 15

FIG - 16



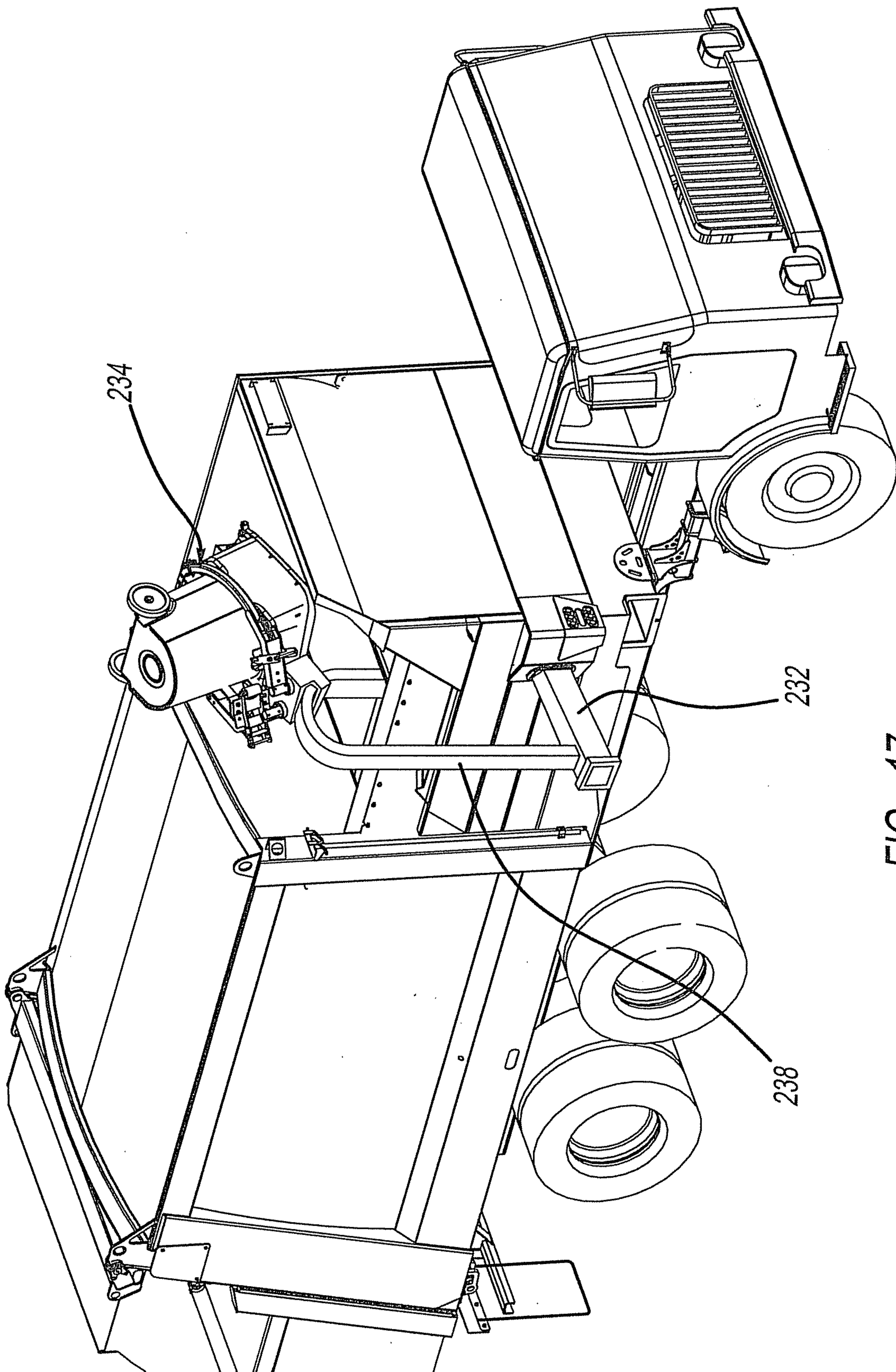

FIG - 17

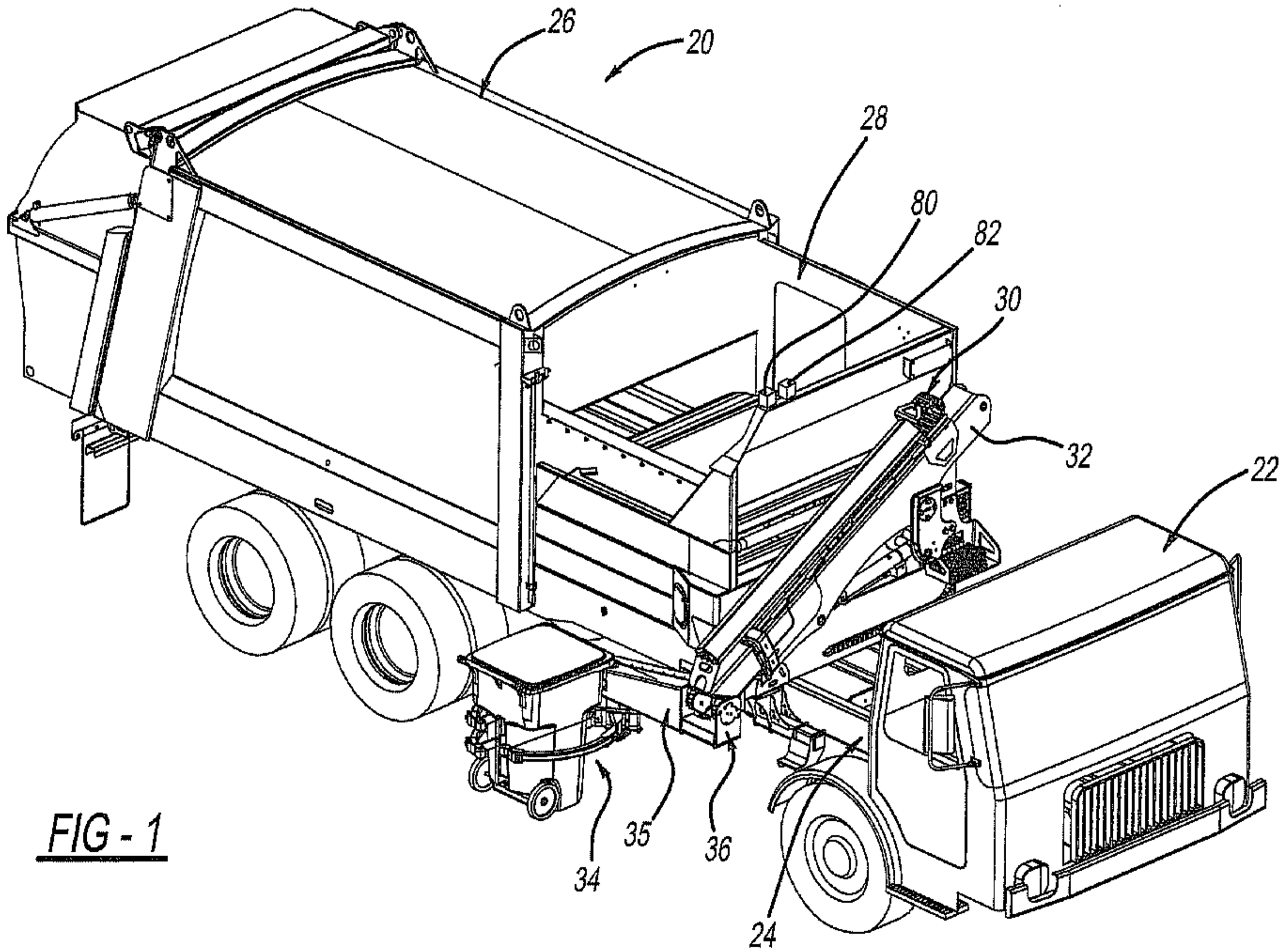

FIG - 1