

(19)



(11)

EP 2 093 328 A2

(12)

EUROPEAN PATENT APPLICATION

(43) Date of publication:
26.08.2009 Bulletin 2009/35

(51) Int Cl.:
E01D 19/08 (2006.01)

(21) Application number: **09002165.0**

(22) Date of filing: **17.02.2009**

(84) Designated Contracting States:
**AT BE BG CH CY CZ DE DK EE ES FI FR GB GR
 HR HU IE IS IT LI LT LU LV MC MK MT NL NO PL
 PT RO SE SI SK TR**
 Designated Extension States:
AL BA RS

(72) Inventors:
 • **Vlcek, Petr**
330 08 Zruc-Senec (CZ)
 • **Vlcek, Radek**
330 33 Mesto Tousek (CZ)

(30) Priority: **19.02.2008 CZ 20080090**

(74) Representative: **Langrova, Irena**
Skretova 48
301 00 Plzen (CZ)

(71) Applicant: **Bruj, Vaclav**
Sedlecko 5
338 24 Brasy (CZ)

(54) Variably connected bridge drainer

(57) The bottom part of the bridge drainer consists of the tray (3). The outlet of the tray (3) is joined to the bridge draining system and the top rim of said tray (3) is shaped to form the collar (3C). On this collar (3C) the waterproofing (11) is located on which the set of the frame (2) with the grating (1) is laid. The grating (1) is joined with the frame (2) by means of the hinge (5) which is located so that the axial junction is perpendicular to the traffic direction on the bridge. The frame (2) has a circular opening in itself on the circumference of which the limiting lugs (10) are made to limit the rotational rectification, said

limiting lugs (10) having the shape of opposite located sectors, rotated by 45° against the vertical axis of said frame (2). The bottom part of said frame (2) is provided with the grooves (9) to drain off the surface of the waterproofing (11) of the bridge. If needed, the drainer system can be modified, during assembling, for diverse thicknesses of the bridge floor layer set by relevant combination of dimensional variants of the rectification rings (4), inserted between the waterproofing (11) and said frame (2). According to the requirement on the water outlet direction, the tray (3) with the vertical outlet (3A) or the tray (3) with the side outlet (3B) can be used.

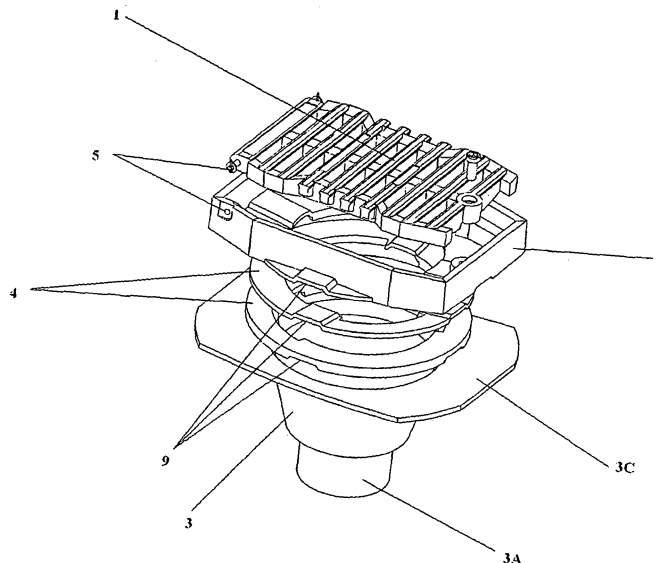

fig. 3

EP 2 093 328 A2

Description

Technical Field

[0001] The invention refers to a bridge drainer, variably fitted for diverse bridge floor types to be used in old stone bridges advantageously.

State of the Prior Art

[0002] The hitherto known technical solution of the bridge floor draining is described in the Czech patent application PV 2002-1544.

[0003] According to it, the drainer consists of four main parts: a tray, a pot, a frame with corner bevels, and a grating. In the rectangular tray there is an outlet hole in which the rectangular pot is located with a circular hole to fasten a dirt strainer. In the pot there is a frame in which a grating is inserted of which the shape is identical with that of the frame. The grating ribs are shortened in the central part and at one shorter grating side the rib is fitted with a lock meshing with a hollow in the frame. At the second shorter grating side the rib is provided with hinge catches with a permanently attached rod by means of which the grating is joined to the frame permanently on the knuckle joint principle. On the outer pot brims, there is a flange with draining holes and the flange fitting is formed around the tray outlet hole. In the horizontal direction the angle of rotation of the permanently joined grating-and-frame set is limited in the extent of $\pm 15^\circ$ and said set can be shifted by 60 mm at most in transversal and/or longitudinal direction. The corner bevels are shaped so that they bear against the longer inner pot wall with the set adjusted to the limit of 15° at most.

[0004] Another known technical solution is described in the Czech patent application PV 1998-2330 in which a draining outlet part of a bridge inlet is described that can be set in the pipeline direction. This outlet part is located in the bridge inlet tray bottom together with the pot with draining holes. In the pot there is a grill of which a frame is placed on shims. The draining outlet part consists of a joint, composed of a segment, a funnel, and central and rotary parts. In the tray bottom there is an opening on circumference of which a flange is made under that there is an inclined part in which a funnel segment is located with a funnel under it. The funnel bottom part passes into the central hemispheric part with the bottom brim bevelled with the inclination that is parallel with that of the funnel wall and bevelled at the same time conformably with the top brim of the rotary part. This has hemispheric shape too from which the smooth pipeline end goes out on the bottom part. In the flange a circular reduction is fastened rigidly with a central hole fitted with a hollow on the circumference to fasten the segment top of which the part is identical with the hollow as for the shape. Between the central and the rotary joint parts there is a sealing ring.

Disclosure of the Invention

[0005] The bridge drainer, according to the proposed solution, consists of a tray in its bottom part. The tray outlet is joined to the bridge draining system and the tray top part is formed as a collar. On this collar the waterproofing is placed on which the frame-and-grating set is located. The waterproofing clamping between the collar and the frame provides its horizontal connection to prevent water from leaking into the bridge structure bottom part. The grating is joined with the frame by means of a hinge that is located so that the junction is perpendicular to the traffic direction on the bridge. In the frame there is a circular opening on which the limiting lugs are made on the circumference to limit the rotational rectification where the lugs have the shape of opposite located sections rotated partially by 45° against the frame vertical axis. The frame bottom surface is provided with grooves to drain off the bridge insulation surface.

[0006] A variant solution is based on the possibility to set the bridge drainer for diverse thick bridge floor types which is provided by corresponding combination of dimensional variants of rectification rings inserted between the waterproofing and the frame. The rectification ring has circular shape with conical top and bottom surfaces. The rectification ring bottom surface is identically shaped as the frame bottom surface and the top part of the rectification ring has the same shape as the collar top part. In case one rectification ring is used at least, the waterproofing is clamped between the rectification ring and the tray collar.

[0007] Further, according to the actual bridge type, a tray with a vertical outlet or that with a side outlet can be used. Due to this variability the bridge drainers can be used both on up-to-date bridges and on old ones where the draining can be led into stone gargoyles.

Brief Description of the Drawings

[0008] The described bridge drainer solution is obvious from following figures of which

Fig. 1 shows the frame bottom side with limiting lugs and draining grooves,

Fig. 2 shows the frame top side with the hinge, lock, and grooves to drain the insulation surface,

Fig. 3 presents the perspective view of a complete bridge drainer set in the decomposed state,

Fig. 4 is the perspective bottom view on the tray in side outlet realization,

Fig. 5 is the side view of a complete set of the bridge drainer set in the composed state.

Example of the Invention

Example no. 1

[0009] A bridge drainer has been made according the

proposed solution. The bridge drainer bottom part consists of the tray 3, provided with the side outlet 3B in this case. Between the collar 3C of the tray 3 and the rectification ring 4 the waterproofing 11 is fitted in a waterproof way to prevent water from leaking into the bridge structure bottom parts from the bridge floor surface. The surface of the waterproofing 11 is drained into the bridge drainer by means of four grooves 9. The number and thickness of the rectification rings 4 enable to set the bridge drainer for required thickness of the bridge floor layers set. In this case this rectification ring 4 is 25 mm thick. On the rectification ring 4 the top part of the bridge drainer is placed consisting of the frame 2 with the grating 1 that is attached by means of the hinge 5 to the frame 2 and secured with the lock 8. The device is located so that the axial junction of the hinge may be perpendicular to the traffic direction on the bridge. Two limiting lugs 10 are made on the circumference of the circular opening in the frame 2. They are formed as opposite sectors rotated by 45° against the vertical axis of the frame 2.

[0010] In the bottom part of the tray 3 the bridge drainer can have the vertical outlet 3A or the side outlet 3B. Thanks to its variability, based on arbitrary number of rings of diverse thickness and two possible outlet variants, this arrangement can be used advantageously for old stone bridges where the outlet can be led in original gargoyles.

List of Reference Symbols

[0011]

1 - grating	
2 - frame	
3 - tray	35
3A - vertical outlet	
3B - side outlet	
3C - collar	
4 - rectification ring	
5 - hinge	40
8 - lock	
9 - grooves to drain off the insulation surface	
10 - limiting lug	
11 - waterproofing	45

Claims

1. The variably connected bridge drainer, applicable for stone vault bridges advantageously, with the tilting grating (1) and the lock (8) being part of said bridge drainer to lock the grating (1) in the frame (2), said bridge drainer being located on the bridge floor rim and being part of the traffic or walking surface of the bridge, **characterized in that**, in the bottom part of the device there is the tray (3) of which the outlet is joined to the bridge draining

system, and the top rim of said tray (3) is shaped as the collar (3C),

on the collar (3C) the waterproofing (11) is fastened in a waterproof way and thereon the set of the frame (2) with the grating (1) is located, said frame (1) and said grating (2) being joined by the hinge (5) that is placed so that its axial junction is perpendicular to the traffic direction,

the frame (2) has a circular opening on the circumference of which the limiting lugs (10), to limit the rotational rectification, are made in the shape of opposite located sectors, rotated by 45° against the vertical axis of the frame (2), and simultaneously the bottom part of the frame (2) is provided with grooves (9) to drain off the bridge insulation surface.

2. The variably connected bridge drainer according to the Claim 1, **characterized in that**, between the waterproofing (11) and the frame (2) at least one rectification ring (4) is placed, said rectification ring (4) having circular shape with conical top and bottom surfaces and further the bottom surface of said rectification ring (4) copies, by its shape, the shape of the bottom surface of said frame (2), and the top surface of said rectification ring (4) copies the shape of the top surface of said collar (3C).
3. The variably connected bridge drainer according to the Claims 1 and 2, **characterized in that**, in the bottom part of said tray (3) the vertical outlet (3A) is located or in the bottom part of said tray (3) the top outlet (3B) is located.

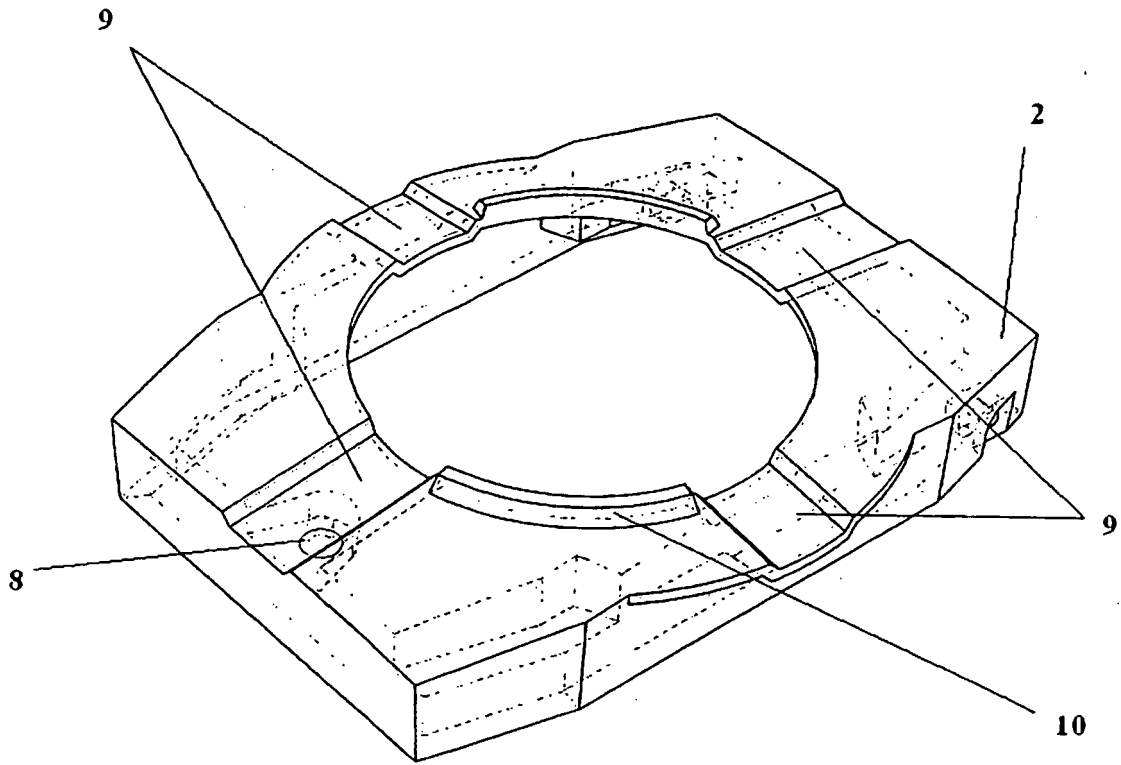

fig. 1

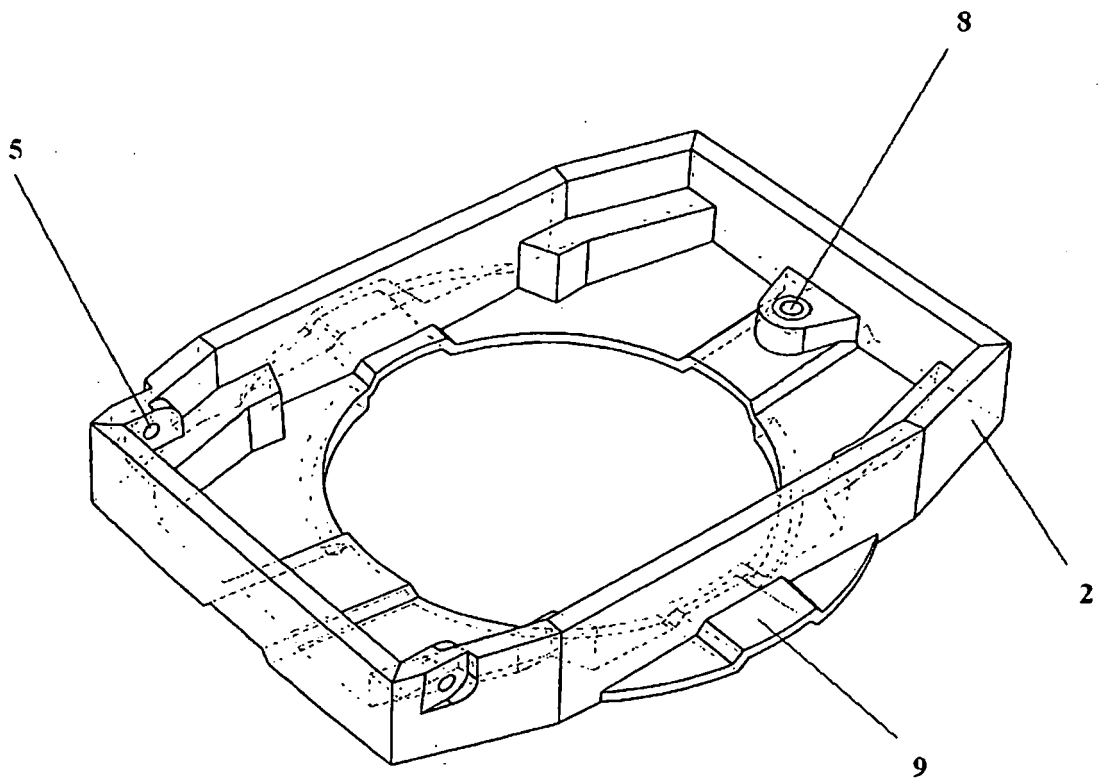

fig. 2

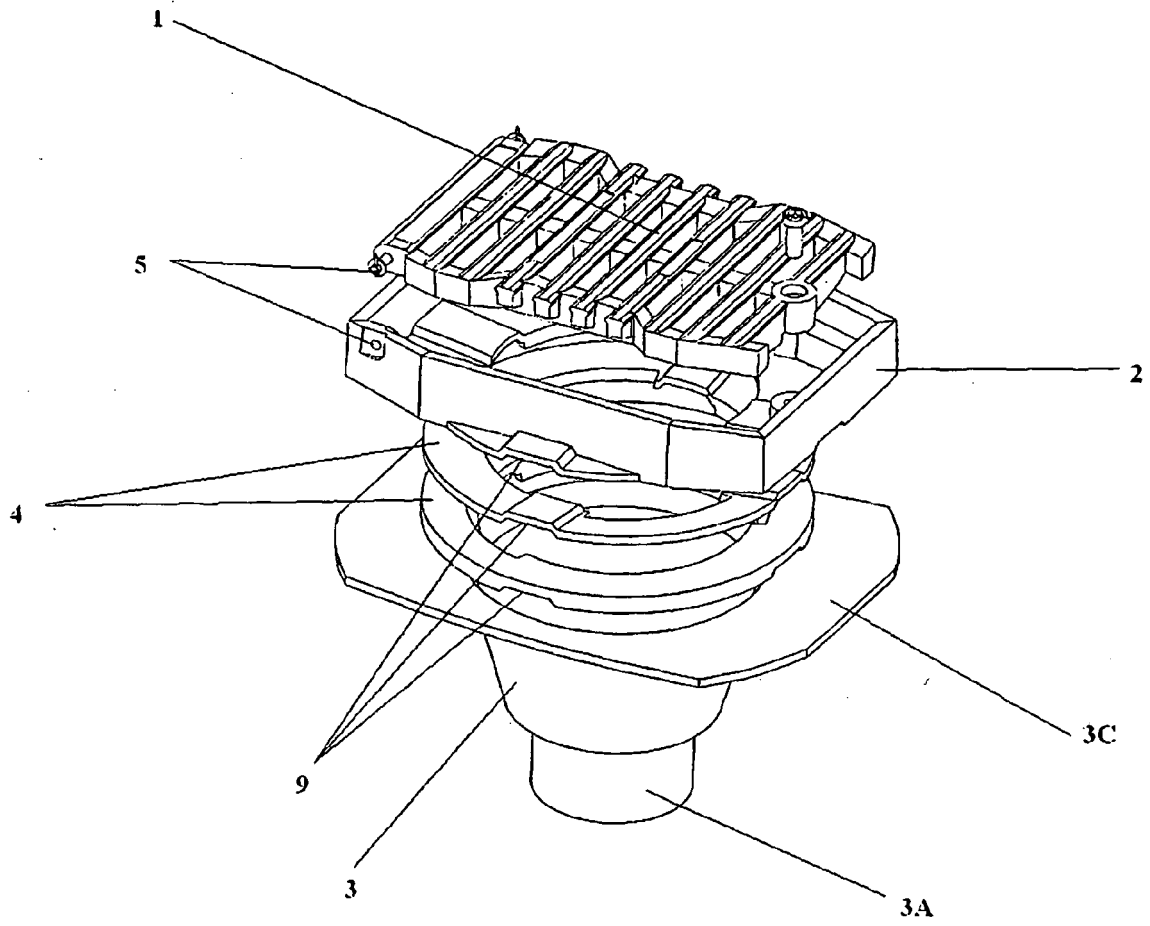

fig. 3

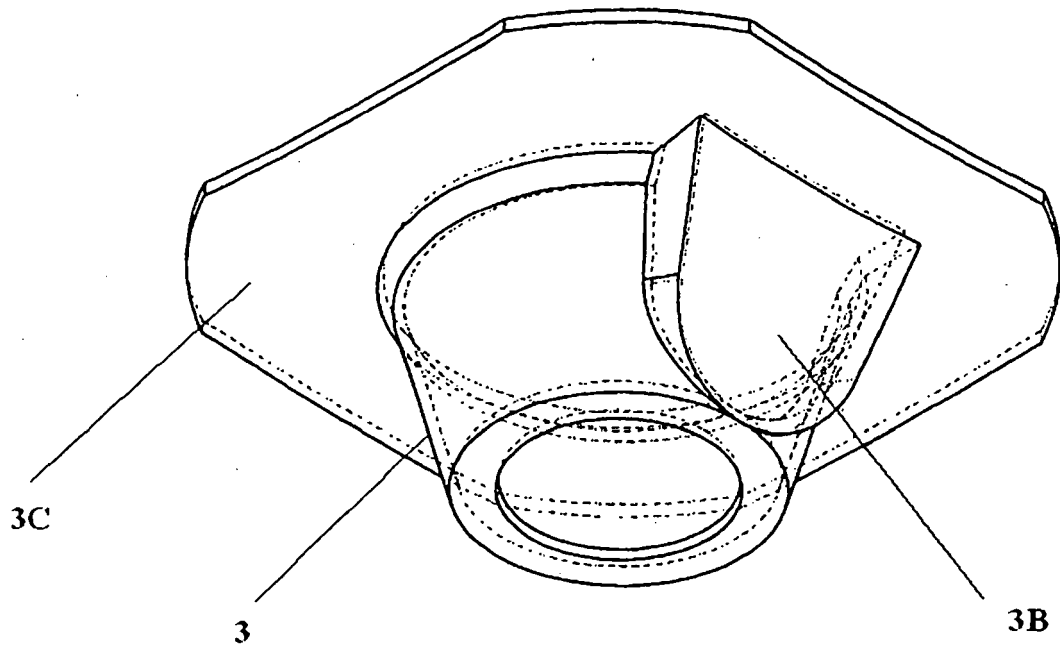

fig. 4

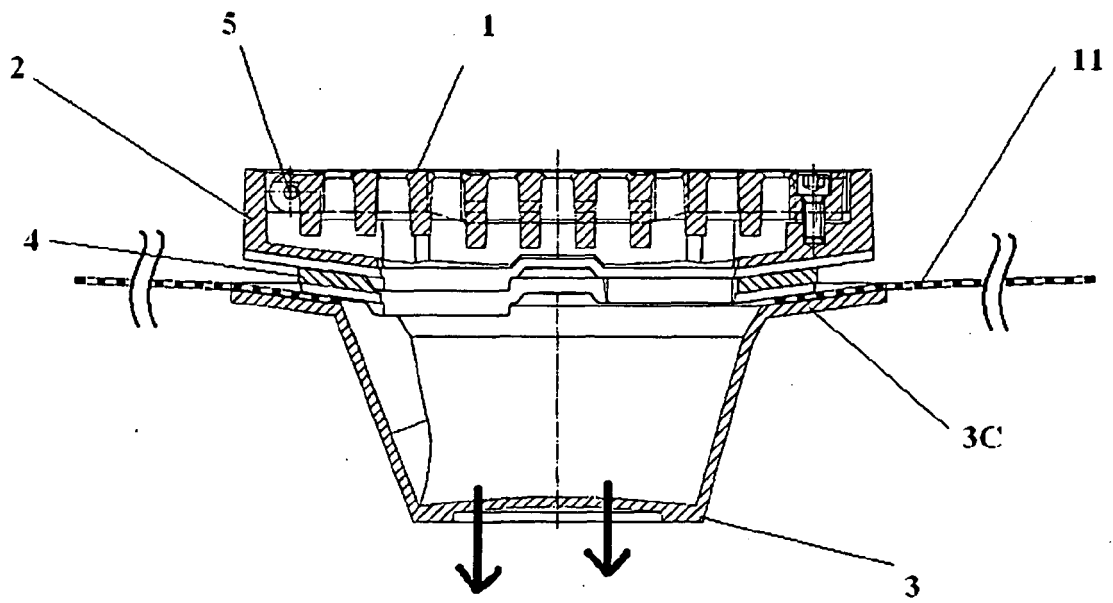

fig. 5

REFERENCES CITED IN THE DESCRIPTION

This list of references cited by the applicant is for the reader's convenience only. It does not form part of the European patent document. Even though great care has been taken in compiling the references, errors or omissions cannot be excluded and the EPO disclaims all liability in this regard.

Patent documents cited in the description

- CZ PV20021544 [0002]
- CZ PV19982330 [0004]