



US00D894085S

(12) **United States Design Patent**
Liu

(10) **Patent No.:** **US D894,085 S**

(45) **Date of Patent:** **** Aug. 25, 2020**

(54) **VEHICLE WHEEL**

(71) Applicant: **CITIC Dicastal Co., Ltd.**,
Qinhuangdao (CN)

(72) Inventor: **Zhichong Liu**, Qinhuangdao (CN)

(73) Assignee: **CITIC Dicastal Co., Ltd.**,
Qinhuangdao (CN)

(**) Term: **15 Years**

(21) Appl. No.: **29/707,543**

(22) Filed: **Sep. 29, 2019**

(30) **Foreign Application Priority Data**

Jun. 17, 2019 (CN) 2019 3 0311951

(51) **LOC (12) CL.** **12-16**

(52) **U.S. Cl.**
USPC **D12/209**

(58) **Field of Classification Search**
USPC D12/204–213; D21/563
CPC B60B 7/00; B60B 7/02; B60B 7/04; B60B
7/01; B60B 7/06; B60B 3/02; B60B 3/04;
B60B 3/06; B60B 3/10; B60B 1/00;
B60B 1/08; B60B 1/10; B60B 1/12

See application file for complete search history.

(56) **References Cited**

U.S. PATENT DOCUMENTS

D733,633	S	*	7/2015	Gardavsky	D12/211
D751,015	S	*	3/2016	Mahoney	D12/209
D756,882	S	*	5/2016	Tirado	D12/211
D792,311	S	*	7/2017	Gallert	D12/211
D797,637	S	*	9/2017	Wolff	D12/211
D825,429	S	*	8/2018	Myrberg	D12/209
D857,596	S	*	8/2019	Liu	D12/211
D877,680	S	*	3/2020	Tran	D12/209
D878,273	S	*	3/2020	Tovey	D12/209
D885,294	S	*	5/2020	Chi	D12/211

* cited by examiner

Primary Examiner — Stacia A Cadmus

(74) *Attorney, Agent, or Firm* — IPPro, LLC; Qian Gu

(57) **CLAIM**

The ornamental design for a vehicle wheel, as shown and described.

DESCRIPTION

FIG. 1 is a front view of a vehicle wheel.
FIG. 2 is a perspective view of the vehicle wheel; and,
FIG. 3 is a left side view of the vehicle wheel.
The broken line showing of the rear of the rim, the valve stem hole, the bolt holes and the center hole in the central hub area is included for the purpose of illustrating environment and forms no part of the claimed design.

1 Claim, 3 Drawing Sheets

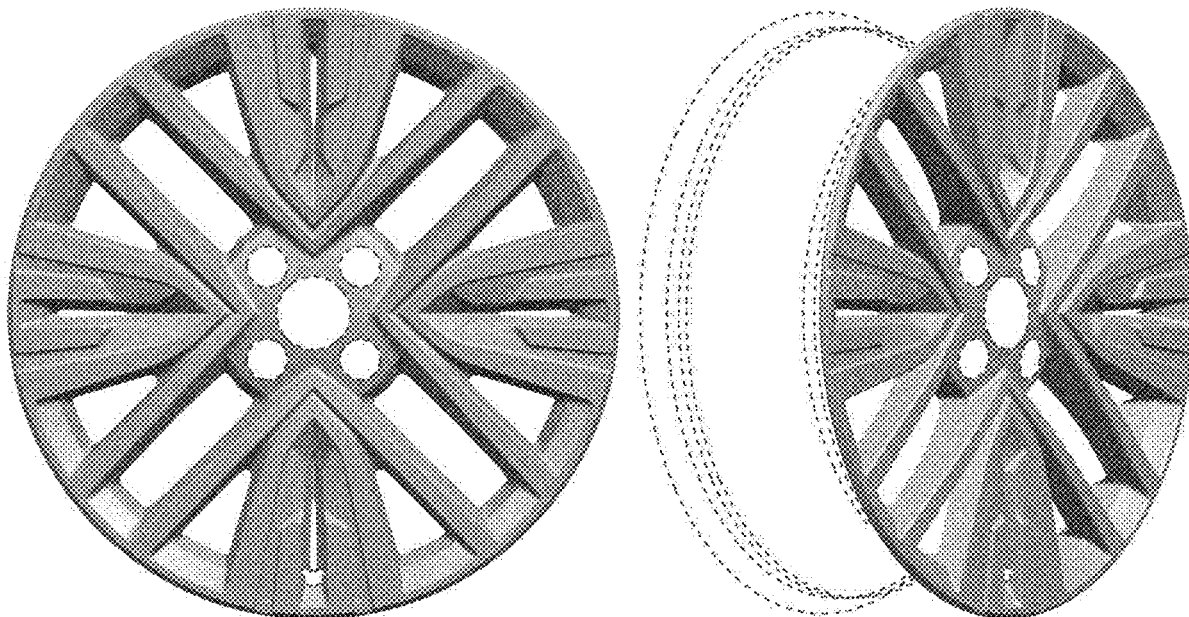

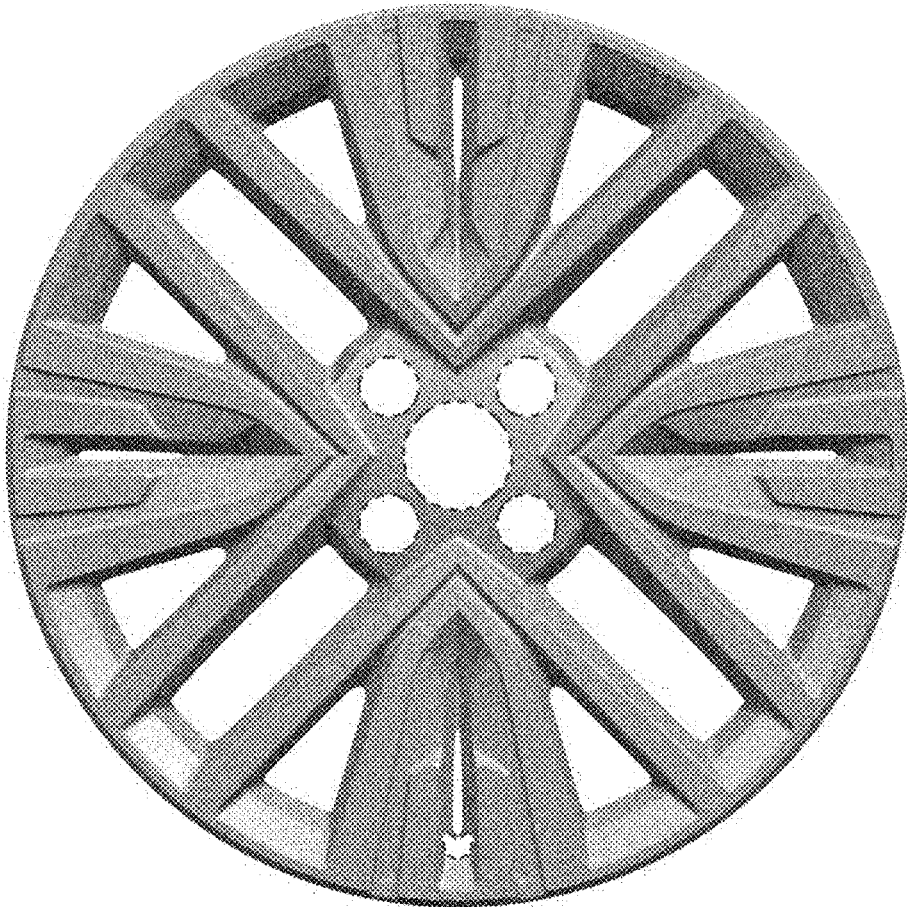

FIG. 1

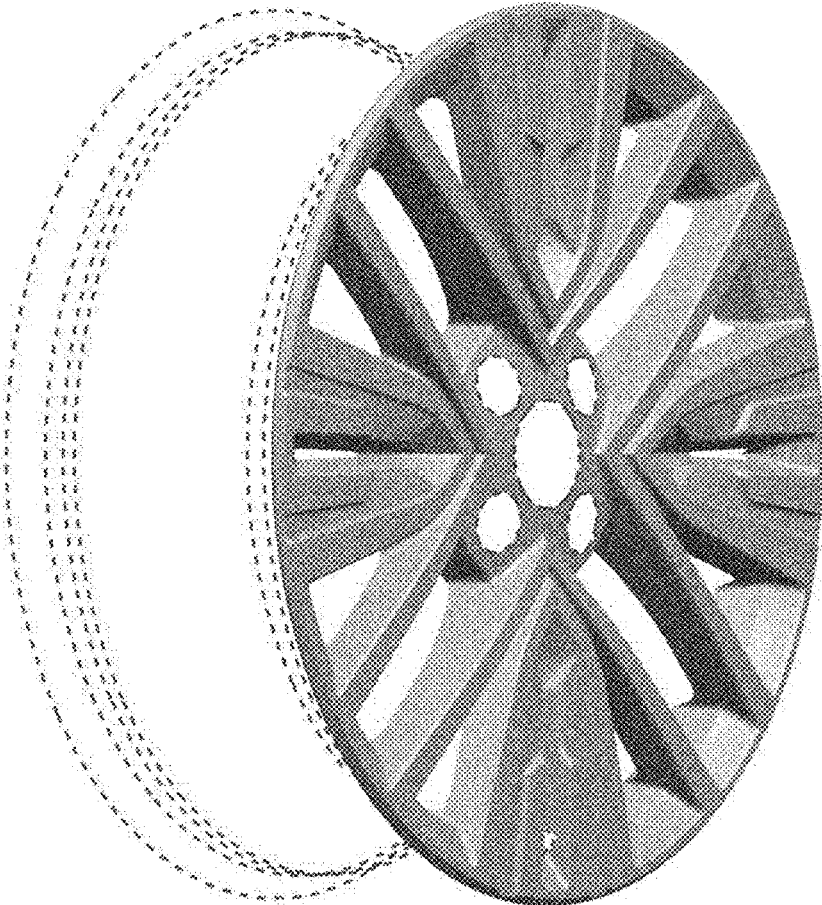

FIG. 2

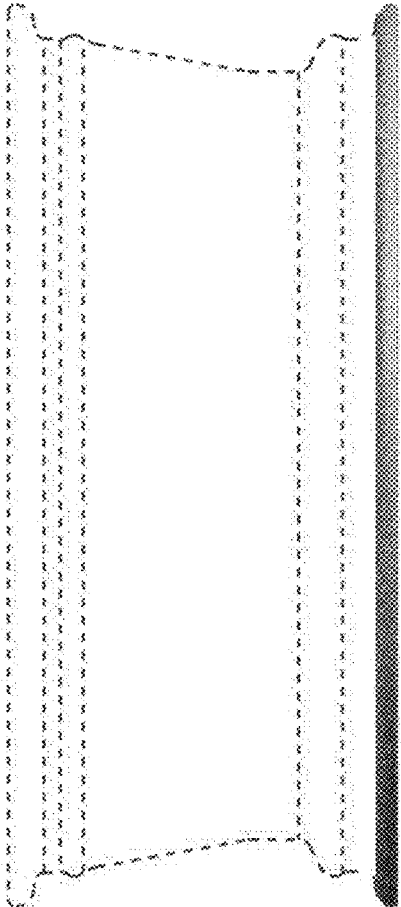

FIG. 3