

⑫

**EUROPEAN PATENT SPECIFICATION**

- ④⑤ Date of publication of patent specification: **10.07.85**      ⑤① Int. Cl.<sup>4</sup>: **G 02 F 1/315, G 02 F 1/03**  
②① Application number: **82301659.7**  
②② Date of filing: **30.03.82**

---

④④ **Multigate light valve for electro-optic line printers having non telecentric imaging systems.**

---

③③ Priority: **30.03.81 US 249057**

④③ Date of publication of application:  
**06.10.82 Bulletin 82/40**

④⑤ Publication of the grant of the patent:  
**10.07.85 Bulletin 85/28**

③④ Designated Contracting States:  
**DE FR GB IT**

⑤③ References cited:  
**EP-A-0 021 754**  
**US-A-4 125 318**

**SIEMENS FORSCHUNGS-UND  
ENTWICKLUNGSBERICHTE**, vol. 10, no. 1,  
February 1981, pages 44-47, Wurzburg (DE); F.  
AURACHER et al.: "New electrooptic bragg  
deflectors with low-insertion loss and  
multiple-beam capability"

⑦③ Proprietor: **XEROX CORPORATION**  
**Xerox Square - 020**  
**Rochester New York 14644 (US)**

⑦② Inventor: **Sprague, Robert A.**  
**13755 Calle Tacuba**  
**Saratoga California 95070 (US)**

⑦④ Representative: **Weatherald, Keith Baynes et al**  
**European Patent Attorney Rank Xerox Limited**  
**Patent Department 338 Euston Road**  
**London NW1 3BH (GB)**

---

Note: Within nine months from the publication of the mention of the grant of the European patent, any person may give notice to the European Patent Office of opposition to the European patent granted. Notice of opposition shall be filed in a written reasoned statement. It shall not be deemed to have been filed until the opposition fee has been paid. (Art. 99(1) European patent convention).

---

## Description

This invention relates to devices comprising multigate light valves and, more particularly, to electro-optic line printers and the like having non-telecentric imaging systems.

As is known, an electro-optic element having a plurality of individually addressable electrodes may be employed as a multigate light valve in, say, an electro-optic line printer. See, "Light Gates Give Data Recorder Improved Hardcopy Resolution," *Electronic Design*, July 19 1979, pp. 31—32; "Polarizing Filters Plot Analog Waveforms," *Machine Design*, Vol 51, No. 17, July 26 1979, p. 62; and "Data Recorder Eliminates Problem of Linearity," *Design News*, February 4 1980, pp. 56—57.

Substantial progress has been made in developing such light valves and in applying them to electro-optic line printing.

For successful line printing with a multigate light valve of the foregoing type, the zero order diffracted components of the light emerging therefrom are brought to focus at the center of the entrance pupil of an imaging lens (hereinafter simply referred to as the center of the imaging lens) which, in turn, images the light valve onto the recording medium. In other words, the zero order components of the output beam are collected as the principal rays for imaging. This ensures that substantially the same amount of light is collected from each of the many electrode pairs of the electro-optic element and that more or less uniform imaging conditions are maintained across essentially the full width of the light valve, as exemplified in EP—A—21754.

Prior multigate light valves have generally had parallel electrode geometrics. For that reason, the standard practice has been to illuminate such a light valve with an input beam which is collimated in a direction parallel to the electrodes, such that the zero order diffracted components of the output beam emerge along parallel paths which are normal to the light valve. This means that a telecentric imaging system is needed to collect the zero order diffraction components as the principal rays for imaging (as a matter of definition, a "telecentric imaging system" is one in which all principal rays are normal to the surface of the object being imaged). For example, a field lens is commonly used to bring the zero order light to focus at the center of an imaging lens. Unfortunately, however, the field lens tends to create unwanted field curvature and to introduce undesirable optical aberrations. Accordingly, a relatively complex and expensive imaging lens is usually required to obtain a reasonably flat and distortion-free image of the light valve in the image plane (i.e. on the surface of the photosensitive recording medium).

In accordance with the present invention, to reduce the complexity and cost of the optics required for electro-optic line printing and similar functions, the device specified in claim 1 is provided. In this device, a multigate light valve

having converging electrodes is illuminated by a light beam which converges toward the center of the entrance pupil of an imaging lens. The electrodes and the light beam converge toward that point at substantially the same angle of convergence so that the light beam effectively remains longitudinally parallel to the electrodes as it passes through the electro-optic element of the light valve.

Still other features and advantages of embodiments of this invention will become apparent when the following detailed description is read in conjunction with the attached drawings, in which:

Figure 1 is a schematic side view of an electro-optic line printer having a non-telecentric imaging system in accordance with the present invention;

Figure 2 is an enlarged bottom plan view of a portion of the printer shown in Figure 1;

Figure 3 is an enlarged side view of the TIR light valve used in the line printer shown in Figure 1;

Figure 4 is an enlarged cut-away, bottom view of the light valve shown in Figure 3 to illustrate the converging geometry of its electrodes in keeping with this invention;

Figure 5 is a simplified block diagram of a system for applying differentially encoded input data samples to the individually addressable electrodes of the light valve shown in Figure 4; and

Figure 6 is an enlarged, cut-away bottom view of a TIR light valve having a converging set of individually addressable electrodes interleaves with a converging set of reference plane electrodes in accordance with an alternative embodiment of the present invention.

Turning now to the drawings, and at this point especially to Figures 1 and 2, there is an electro-optic line printer 11 having a fringe field responsive multigate light valve 12 for printing an image on a photosensitive recording medium 13. As shown, the recording medium 13 is a photoconductively coated drum 14 which is rotated (by means not shown) in the direction of the arrow. Nevertheless, it will be evident that there are other xerographic and non-xerographic recording media that may be used, including photoconductively coated belts and plates, as well as photosensitive films and coated papers. Thus, in the generalized case, the recording medium 13 should be visualized as being a photosensitive medium which is exposed while advancing in a cross line or line pitch direction relative to the light valve 12.

As best illustrated in Figures 3 and 4, the light valve 12 comprises an optically transparent electro-optic element 17 and a plurality of individually addressable electrodes 18a—18i. The most promising electro-optic materials for such a device presently appear to be  $\text{LiNbO}_3$  and  $\text{LiTaO}_3$ , but there are others which warrant consideration, including BSN, KDP,  $\text{KD}^*\text{P}$ ,  $\text{Ba}_2\text{NaNb}_5\text{O}_{15}$  and PLZT. In this particular embodiment, the light valve 12 is operated in a Total Internal Reflection (TIR) mode. Consequently, the electro-optic element 17 is suitably a y-cut crystal of, say,  $\text{LiNbO}_3$

having an optically polished reflecting surface 21 extending between opposed, optically polished input and output faces 22 and 23, respectively.

Concentrating for a moment on Figures 1—3, it will be seen that the line printer 11 includes a laser 31 or similar source for supplying an input light beam 32 and a beam expander 33 for laterally expanding the input beam 32 so that it illuminates substantially the full width of the electro-optic element 17. In keeping with accepted practices, to operate the light valve 12 in a TIR mode, the input beam 32 is transmitted through the input face 22 of the electro-optic element 17 at a grazing angle of incidence relative to the reflecting surface 21 (i.e., an angle no greater than the critical angle of incidence for total internal reflectance from the surface 21) and is brought to a wedge shaped focus on that surface approximately midway through the electro-optic element 17. Consequently, the input beam 32 is totally internally reflected from the reflecting surface 21 to provide an output beam 34 which exits from the electro-optic element 17 through its output face 23.

In accordance with the present invention, the input beam 32 is applied to the electro-optic element 17 through one or more lenses 35 which are selected to have different focal powers laterally and longitudinally of the light valve 12. More particularly, the longitudinal focal power of the lenses 35 (i.e., the focal power along the optical axis of the light valve 12) is selected so that the input beam 32 is brought to a wedge shaped focus on the reflecting surface 21, as previously indicated. On the other hand, the lateral focal power of the lenses 35 is selected so that the input beam 32 converges with a predetermined angle of convergence toward the center of the imaging lens 36.

To carry out the present invention, as shown in Figure 4, the electrodes 18a—18i are more or less uniformly distributed in spaced apart relationship across essentially the full width of the electro-optic element 17 and are oriented to longitudinally converge toward the center of the imaging lens 36 with substantially the same angle of convergence as the input beam 32. As described in more detail hereinbelow, the phase front of the output beam 34 is spatially modulated in accordance with the differentially encoded data samples appearing on the electrodes 18a—18i at any given point in time. Thus, Schlieren central dark field or bright field imaging optics are employed to convert the spatial phase front modulation of the output beam 34 into a correspondingly modulated intensity profile and to supply any magnification needed to obtain an image of the desired size on the recording medium 13. Here, for example, there are central dark field imaging optics 37 comprising the imaging lens 36 and a stop 38. To provide a central dark field, the stop 38 is centered on the entrance pupil of the imaging lens 36.

Since the electrodes 18a—18i and the input beam 32 converge toward the center of the

imaging lens 36 at substantially the same angle of convergence, the principal rays of the output beam 34 are its zero order diffraction components. The central dark field character of the imaging optics 37 follows from the fact that the zero order diffraction components of the output beam 34 are focused on the stop 38, while its higher order diffraction components scatter around the stop 38 and are collected by the imaging lens 36. Thus, the imaging lens 36 focuses the higher order diffraction components of the output beam 34 on the recording medium 13, thereby providing an intensity modulated image of the light valve 12.

Referring now to Figure 5, to perform line printing, serial input data samples, which represent picture elements for successive lines of an image, are applied to a differential encoder 41 at a predetermined data rate. The encoder 41 differentially encodes the input samples on a line-by-line basis in response to control signals from a controller 42, and a multiplexer 43 responds to further control signals from the controller 42 to ripple the encoded data samples onto the electrodes 18a—18i at a ripple rate which is matched to the data rate. The input data may, of course, be buffered (by means not shown) to match the input data rate to any desired ripple rate. Moreover, the input data may be processed (by means also not shown) upstream of the encoder 41 for text editing, formatting or other purposes, provided that the data samples for the ultimate image are applied to the encoder 41 in adjacent picture element sequence.

As a matter of definition each differentially encoded data sample, other than the first sample for each line of the image, has a magnitude whose difference from the previous differentially-encoded data sample corresponds to the magnitude of a respective input data sample. The first sample for each line of the image is referenced to a common reference potential, such as ground. Thus, all picture elements are faithfully represented by the electrode-to-electrode voltage drops that are produced in response to the differentially-encoded data.

Returning to Figures 1—4, it will be understood that the electrode-to-electrode voltage drops appearing between the electrodes 18a—18i create localized fringe fields. To couple these fields into the electro-optic element 17 of the light valve 12, the electrodes 18a—18i are supported on or very near its reflecting surface 21. For example, as shown, the electrodes 18a—18i are defined by suitably patterning a metallised layer of, say, a VLSI silicon circuit 51. Furthermore, the silicon circuit 51 is pressed or otherwise firmly held against the electro-optic element 17, as indicated by the arrows 52 and 53 (Figure 3), to maintain the electrodes in contact with or closely adjacent to the reflecting surface 21. The advantage of this construction is that the silicon circuit 51 may be used to make the necessary electrical connections to the electrodes 18a—18i.

The fields coupled into the electro-optic ele-

ment 17 cause localized variations in its refractive index widthwise of an interaction region 54 (Figure 3). Inasmuch as the electrode-to-electrode voltage drops are equal to the magnitudes of successive ones of the raw input data samples relative to, say, ground, the magnitude of the refractive index variations which are produced in response to the encoded data samples for any given line of the image faithfully represent the raw input data samples for that line. Consequently, the phase front of the output beam 34 is sequentially spatially modulated in accordance with sets of data samples for successive lines of the image. As previously mentioned, the Schlieren optics 37 convert the phase front modulation of the output beam 34 into a corresponding intensity profile.

In summary, as indicated in Figure 2 by the broken lines 55, each adjacent pair of electrodes, such as 18a and 18b (Figure 4), cooperates with the electro-optic element 17 and with the imaging optics 37 to effectively define a local modulator for creating a picture element at a unique, spatially predetermined position along each line of the image. Since the input data are differentially encoded and all of the electrodes 18a—18i are individually addressable, the number of picture elements that can be printed/scan line is equal to the number of electrodes 18a—18i. Moreover, since the focusing lens or lenses 35 are on the input side of the light valve 12, they contribute relatively little curvature or distortion to the image.

Turning to the alternative embodiment shown in Figure 6, it will be evident that the present invention may also be applied to a light valve 61 having a plurality of individually addressable electrodes 62a—62i alternating with a corresponding plurality of reference or ground plane electrodes 63a—63i. As compared with the embodiment shown in Figures 1—5, the major advantage of this embodiment is that the raw input data are directly applied to the individually addressable electrodes 62a—62i so as to avoid the additional cost and complexity of differential encoding, and its basic disadvantage is that twice as many electrodes are required to print a given number of picture elements/line. Indeed, this alternative embodiment is otherwise so similar to the embodiment described hereinabove that it need not be described in any further detail. Instead like reference numerals have been used to identify like parts.

### Claims

1. A device for controllably converting a beam of light (32) into an image which consists of a line of intensity-modulated light spots, comprising a multigate light-valve (12), means (31, 33, 35) for applying a beam of light to said light valve, said beam impinging on the full width of said light valve, and Schlieren imaging optics (37) arranged to image the light beam onto an image plane, the multigate light valve comprising an electro-optic element having a plurality of individually address-

able electrode strips (18, 62) arranged longitudinally to the light beam on one of the surfaces of the electro-optic element for applying localized electric fields to the electro-optic element, characterised in that, in the plane defined by the said one surface, the beam of light impinging on the light valve converges toward a point in the centre of the entrance pupil of the imaging optics, and in that the electrode strips also converge toward the said point, whereby even in the said plane the light valve is imaged onto the image plane by non-telecentric imaging optics.

2. The device of claim 1, wherein the light valve includes

a separate substrate (51) for supporting the electrode strips, and

means (52, 53) for holding the substrate against the electro-optic element, whereby the electrode strips are maintained closely adjacent to said electro-optic element.

3. The device of claim 1 or 2, wherein

the electrode strips comprise a plurality of electrodes (62) interdigitated with a plurality of reference electrodes (63).

4. The device of any preceding claim, wherein the electro-optic element has an optically polished reflecting surface (21)

to which the electrode strips are adjacent, the beam being applied to the electro-optic element so that it meets the reflecting surface internally at a grazing angle of incidence for a TIR mode of operation of the light valve, and

the means for applying the beam includes a lens system (35) having a focal power longitudinally of the light valve which brings the light beam to a wedge-shaped focus on the reflecting surface.

5. An electro-optic line printer comprising a device (12) as claimed in any preceding claim; and

a photosensitive recording medium (13) which advances in a cross-line direction relative to said light valve and on which falls the focused line of intensity-modulated light spots.

### Revendications

1. Dispositif pour convertir de manière contrôlable un faisceau lumineux (32) en une image qui est constituée d'une ligne de points lumineux modulés en intensité, comprenant une valve de lumière multiporte (12), un moyen (31, 33, 35) pour appliquer un faisceau de lumière à la valve de lumière, le faisceau tombant sur la totalité de la largeur de la valve de lumière, et un système optique Schlieren de formation d'image (37) disposé de manière à donner une image du faisceau lumineux sur un plan-image, la valve de lumière multiporte comprenant un élément électro-optique ayant une pluralité de bandes d'électrodes adressables individuellement (18, 62) disposées longitudinalement au faisceau lumineux sur l'une des surfaces de l'élément électro-optique pour appliquer des champs électriques localisés à l'élément électro-optique, caractérisé en ce que, dans

le plan défini par ladite surface, le faisceau lumineux tombant sur la valve de lumière converge vers un point du centre de la pupille d'entrée du système optique de formation d'image, et en ce que les bandes d'électrodes convergent également vers ce point, d'où il résulte que même dans ledit plan la valve de lumière donne une image sur le plan-image par le système optique de formation d'image non-télécentrique.

2. Dispositif selon la revendication 1, où la valve de lumière comprend:

— un substrat séparé (51) pour supporter les bandes d'électrodes, et

— un moyen (52, 53) pour maintenir le substrat contre l'élément électro-optique, d'où il résulte que les bandes d'électrodes sont maintenues en un endroit étroitement contigu à l'élément électro-optique.

3. Dispositif selon la revendication 1 ou la revendication 2, où:

— les bandes d'électrodes comprennent une pluralité d'électrodes (62) intercalées avec une pluralité d'électrodes de référence (63).

4. Dispositif selon l'une quelconque des revendications précédentes, où:

— l'élément électro-optique comporte une surface réfléchissante polie optiquement (21)

par rapport auquel les bandes d'électrodes sont contiguës;

— le faisceau étant appliqué à l'élément électro-optique de façon à rencontrer la surface réfléchissante, intérieurement, suivant un angle d'incidence rasant pour un mode de fonctionnement de la valve de lumière en RIT, et

— le moyen permettant d'appliquer le faisceau comprend un système de lentilles (35) ayant une puissance focale dans le sens longitudinal de la valve de lumière qui focalise le faisceau lumineux à un foyer en forme de coin sur la surface réfléchissante.

5. Imprimante électro-optique par ligne comprenant:

— un dispositif (12) selon l'une quelconque des revendications précédentes; et

— un milieu d'enregistrement photosensible (13) qui avance dans une direction transversale aux lignes par rapport à la valve de lumière et sur lequel tombe la ligne focalisée de points lumineux modulés en intensité.

#### Patentansprüche

1. Einrichtung zum steuerbaren Umwandeln eines Lichtbündels (32) in ein Bild, welches aus einer Linie intensitätsmodulierter Lichtflecken be-

steht, mit einem Mehrweglichtventil (12), Mitteln (31, 33, 35) zum Anwenden eines Lichtbündels auf das Lichtventil, wobei das Bündel auf die volle Breite des Lichtventils auftrifft, und mit einer Schlieren-Abbildungsoptik (37), die zum Abbilden des Lichtbündels auf eine Bildebene angeordnet ist, wobei das Mehrweglichtventil ein elektrooptisches Element umfaßt, welches eine Vielzahl von einzeln adressierbaren Elektrodenstreifen (18, 62) aufweist, die in Längsrichtung zu dem Lichtbündel auf eine der Oberflächen des elektrooptischen Elementes angeordnet sind, um örtliche, elektrische Felder an das elektrooptische Element anzulegen, dadurch gekennzeichnet, daß das auf das Lichtventil auftreffende Lichtbündel in der durch die eine Oberfläche festgelegten Ebene in Richtung auf einen Punkt in der Mitte der Eintrittspupille der Abbildungsoptik konvergiert und daß die Elektrodenstreifen auch in Richtung auf diesen Punkt konvergieren, wodurch das Lichtventil selbst in dieser Ebene auf die Bildebene durch nichttelezentrische Abbildungsoptik abgebildet wird.

2. Einrichtung nach Anspruch 1, bei der das Lichtventil einen getrennten Träger (51) zum Halten der Elektrodenstreifen und Mittel (52, 53) aufweist, um den Träger gegen das elektrooptische Element zu halten, wodurch die Elektrodenstreifen in enger Nähe an dem elektrooptischen Element gehalten werden.

3. Einrichtung nach Anspruch 1 oder 2, bei der die Elektrodenstreifen eine Vielzahl von Elektroden (62) umfassen, zwischen denen eine Vielzahl von Bezugselektroden (63) verläuft.

4. Einrichtung nach einem der vorhergehenden Ansprüche, bei dem das elektrooptische Element eine optisch polierte, reflektierende Oberfläche (21) aufweist, die die Elektrodenstreifen benachbart sind, wobei das Bündel auf das elektrooptische Element derart angewendet wird, daß es innen auf die reflektierende Oberfläche mit einem streifenden Einfallswinkel für einen TIR-Betriebsmodus des Lichtventils einfällt, und wobei die Mittel zum Anwenden des Bündels ein Linsensystem (35) umfassen, welches in Längsrichtung des Lichtventils ein Fokussierungsvermögen aufweist, durch die das Lichtbündel auf der reflektierenden Oberfläche keilförmig fokussiert wird.

5. Elektrooptischer Zeilendrucker mit einer Einrichtung (12) nach einem der vorhergehenden Ansprüche und einem fotoempfindlichen Aufzeichnungsmedium (13), welches sich in einer Richtung quer zu den Zeilen relativ zu dem Lichtventil vorwärts bewegt und auf welches die Brennlinie der intensitätsmodulierten Lichtflecken fällt.

60

65

5

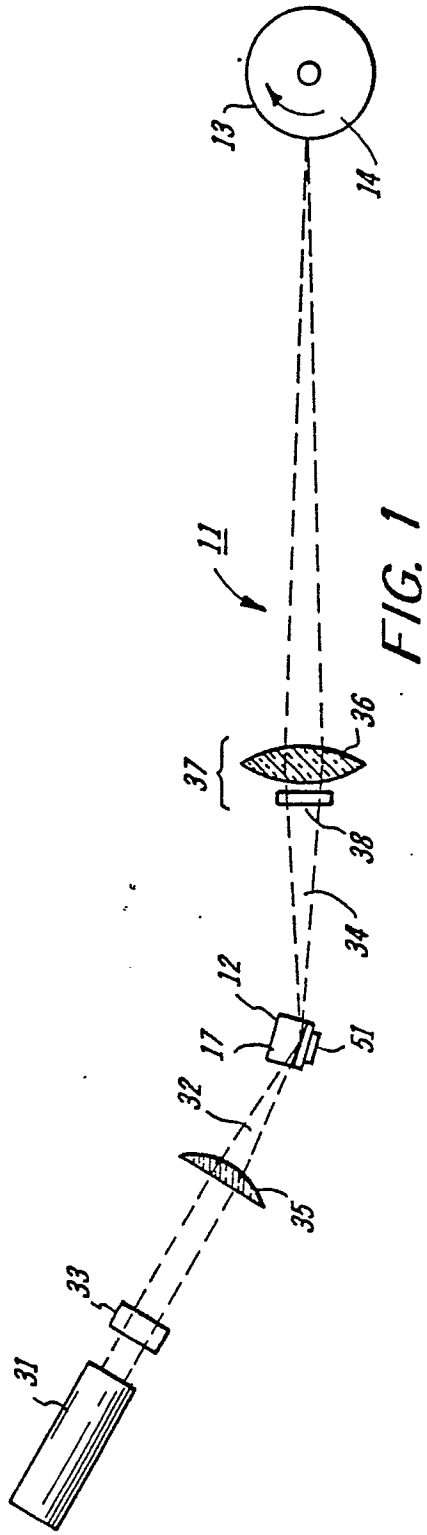

FIG. 1

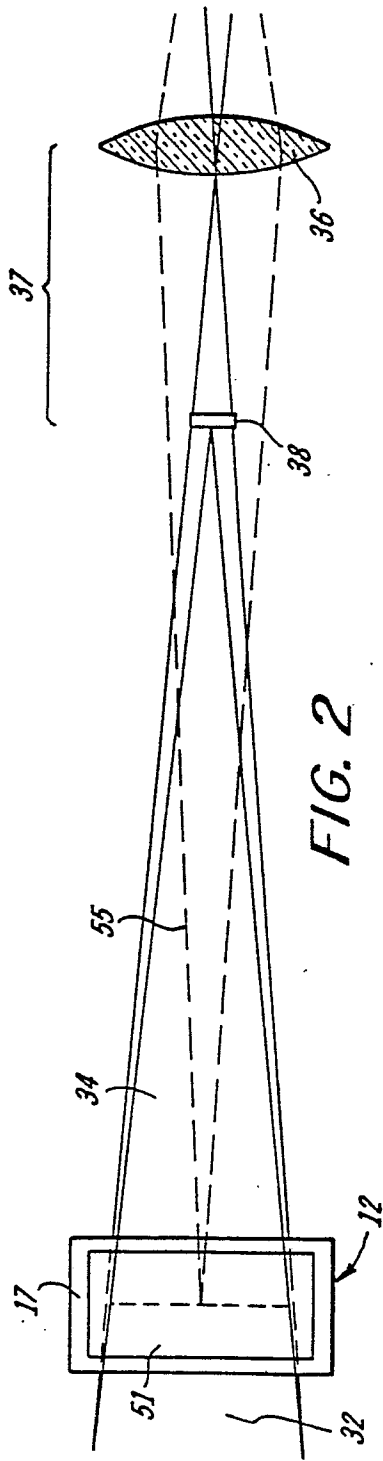

FIG. 2

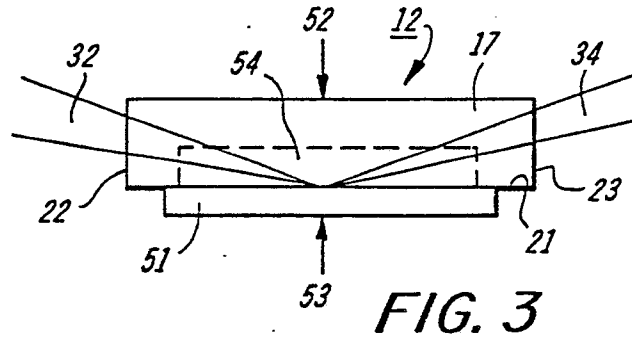

FIG. 3

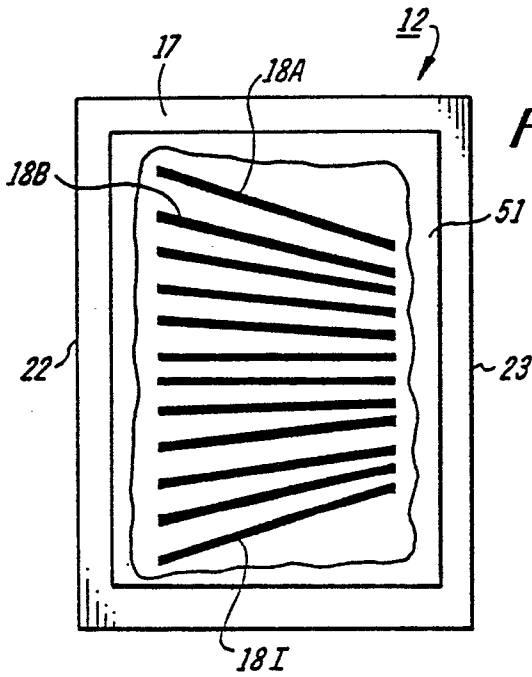

FIG. 4

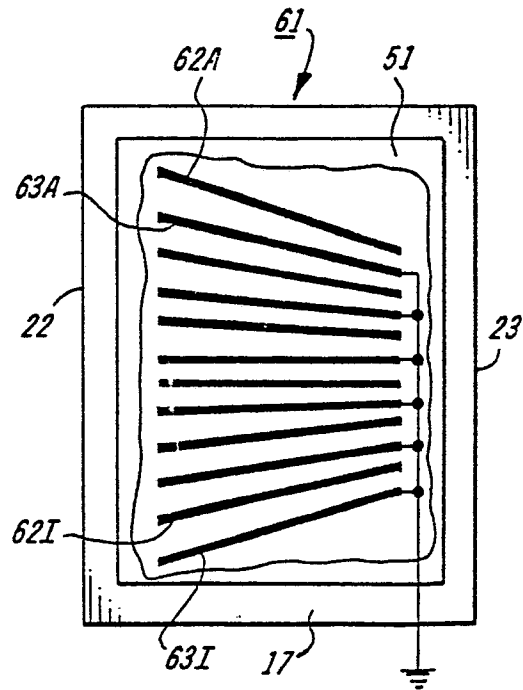

FIG. 6

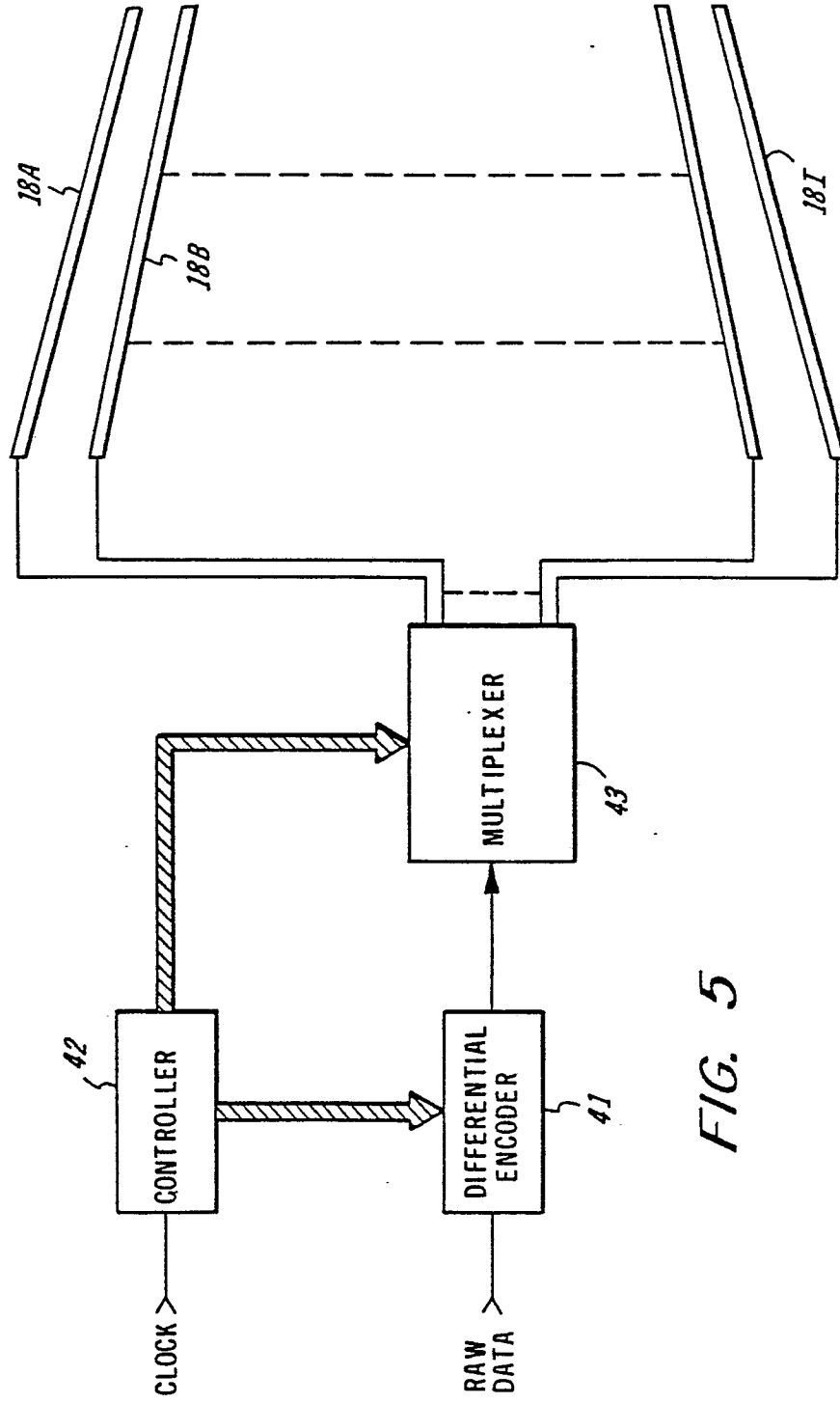

FIG. 5